



Deposited via The University of Leeds.

White Rose Research Online URL for this paper:

<https://eprints.whiterose.ac.uk/id/eprint/87794/>

Version: Published Version

Article:

Billar, P, Sharma, BK, Kunwar, B et al. (2015) Hydroprocessing of bio-crude from continuous hydrothermal liquefaction of microalgae. *Fuel*, 159. pp. 197-205. ISSN: 0016-2361

<https://doi.org/10.1016/j.fuel.2015.06.077>

Reuse

Items deposited in White Rose Research Online are protected by copyright, with all rights reserved unless indicated otherwise. They may be downloaded and/or printed for private study, or other acts as permitted by national copyright laws. The publisher or other rights holders may allow further reproduction and re-use of the full text version. This is indicated by the licence information on the White Rose Research Online record for the item.

Takedown

If you consider content in White Rose Research Online to be in breach of UK law, please notify us by emailing eprints@whiterose.ac.uk including the URL of the record and the reason for the withdrawal request.



Hydroprocessing of bio-crude from continuous hydrothermal liquefaction of microalgae



Patrick Biller^{a,*}, Brajendra K. Sharma^b, Bidhya Kunwar^b, Andrew B. Ross^a

^a Energy Research Institute, School of Chemical and Process Engineering, University of Leeds, UK

^b Illinois Sustainable Technology Center, Prairie Research Institute, University of Illinois, Urbana-Champaign, 1 Hazelwood Drive, Champaign, IL 61820, USA

HIGHLIGHTS

- Novel continuous HTL reactor for microalgae is presented.
- Residence times of 1–6 min resulted in up to 40% bio-crude yields.
- Lower residence time resulted in higher O in bio-crude.
- Hydroprocessing of bio-crude results in reduction of N and O.
- Further reduction of O using solvent extraction possible.

GRAPHICAL ABSTRACT

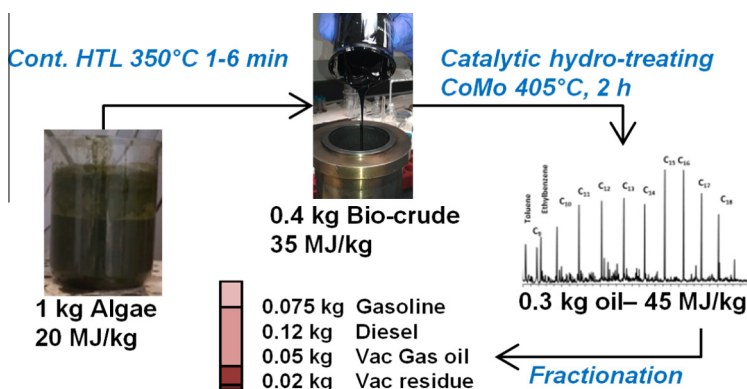

ARTICLE INFO

Article history:

Received 26 March 2015
 Received in revised form 18 June 2015
 Accepted 22 June 2015
 Available online 29 June 2015

Keywords:

Microalgae
 Hydrothermal
 Continuous HTL
 Hydroprocessing
 Hydrotreating
 Bio-crude

ABSTRACT

Hydrothermal liquefaction (HTL) has developed as one of the most promising technologies for biofuel production from wet biomass feedstocks in recent years. In the current study, a microalgae slurry was processed in a continuous flow hydrothermal processing unit capable of 2.5 l/h flow rates, temperatures of 350 °C and pressure of up to 206 bar. 40 wt.% bio-crude yields were obtained when processing *Chlorella* at residence times of 1.4 and 5.8 min. The higher heating value of the bio-crude was approximately 35 MJ/kg, however the nitrogen content of 6% and oxygen content of 11% render it unsuitable for direct combustion. In order to investigate the upgrading potential, the bio-crude was hydroprocessed using CoMo and NiMo catalysts at two temperatures (350 °C and 405 °C) in a stirred reactor. Both catalysts showed similar activity during hydroprocessing. Nitrogen content was typically reduced by 60% at 405 °C whereas oxygen content was reduced by 85%. Fractionation of the upgraded oils result in approximately 25% gasoline, 50% diesel and 25% heavy fuel oil fractions. Further analysis of oils by GC–MS, Sim-Dis and elemental analysis give insight into the fuel quality and nitrogen fractionation. The majority of oxygen is shown to be associated with high molecular weight material and can be reduced further following solvent extraction of the oils while the nitrogen content could only be reduced slightly.

© 2015 The Authors. Published by Elsevier Ltd. This is an open access article under the CC BY license (<http://creativecommons.org/licenses/by/4.0/>).

1. Introduction

Hydrothermal liquefaction has gained increased interest in recent years as it develops as a promising technology for the production of biofuels from wet organic feedstocks. Microalgae have

* Corresponding author at: Energy Research Institute, University of Leeds, LS2 9JT, UK.

E-mail address: p.biller@leeds.ac.uk (P. Biller).

been identified as a particularly suitable feedstock for HTL. Cultivation is performed in aqueous media and minimum energy is required to achieve a feedstock with suitable solids content for processing via HTL [1]. Its high growth rates, lipid contents and non-competition with arable land are advantageous over terrestrial biomass [2]. Research and development in HTL is typically performed at 10–20 wt.% solids in water, temperatures of around 300–350 °C, pressure above the saturation pressure of water and residence times of up to 60 min in batch reactors. This type of research has received tremendous attention in recent years with investigations into different types of algae and varying operating conditions [3–6], various review papers have summarised the research on HTL of microalgae [7–9]. More recently, techno-economic analyses and life cycle assessments have been carried out [10–13]. They show that HTL has a better energy return on investment, lower GHG emission and higher economic potential compared to traditional lipid extraction and transesterification technologies from microalgae. Despite the continuing research efforts, there are still some significant bottlenecks concerning the technology. Although the energy recovery in the primary product bio-crude is high, the quality of bio-crude is still an issue. It contains around 5 wt.% nitrogen, 10 wt.% oxygen and exhibits a high viscosity at room temperature. Researchers have investigated the use of heterogeneous and homogeneous catalysts in-situ to achieve improved bio-crude quality [14,15]. Reductions in oxygen, increased yields and higher energy recoveries were obtained, however particularly the reductions in N were only small. Attention has therefore shifted towards the upgrading of the bio-crude using either catalytic hydrotreating and catalytic hydrothermal treatment [16–19]. Bai et al. investigated the use of 15 different catalysts to upgrade bio-crude via catalytic hydrothermal processing in batch reactors in a H₂ atmosphere [20]. They were able to recover 55–77% upgraded fuel with reductions of O and N in the oils. There are only limited studies on the catalytic hydrotreating of bio-crude without water being present [16,21]. Elliott et al. hydrotreated the bio-crude from continuous HTL using CoMo catalysts in a trickle bed reactor, achieving approximately 80% upgraded oil yield and final O and N levels of ~1 and ~0.1 wt.% respectively. Hydroprocessing of bio-oils from pyrolysis and HTL has been reviewed by Elliott [22]. It has also been suggested that the H₂ required for hydrotreating of bio-crudes can be obtained via catalytic hydrothermal gasification of the organic rich aqueous phase from HTL [23]. This would improve the carbon efficiency and economics of the process while still recovering nutrients such as N and P for the cultivation of algae. The concept of recycling nutrients has successfully been demonstrated on a variety of microalgae strains in batch processes [24–26].

The other bottleneck concerning HTL of microalgae is the lack of continuous processing data. In order to achieve significant scale and market competitiveness, continuous processing is necessary. There are currently only two groups with publications of continuous hydrothermal liquefaction of microalgae [21,27]. Researchers at the Pacific Northwest National Laboratories (PNNL) processed four different microalgae slurries in a continuous flow reactor at ~350 °C and residence times of ~25 to 40 min, leading to bio-crude yields of up to 64 wt.%. Recently Savage's research group was able to show that very low residence times and high heating rates in batch reactors can lead to higher yields and energy recoveries in the bio-crude [28]. These results were confirmed by the work of Jazrawi et al. who processed *Chlorella* and *Spirulina* at residence time of 3–8 min in a continuous HTL reactor and achieved bio-crude yields of up to 42 wt.% [27]. These lower residence times allow for higher throughput and reduced energy consumption in continuous systems. Continuous hydrothermal liquefaction of biomass has recently been reviewed by Elliott et al. [23]; the

review shows the distinct lack of reports in the literature on continuous HTL of microalgae.

In the current investigation results are presented for the processing of a low lipid microalgae *Chlorella* on a custom built continuous reactor system. The bio-crude is upgraded via hydrotreatment using either no catalyst or NiMo and CoMo catalysts at two different temperatures. The performance of the continuous hydrothermal reactor is discussed. Comprehensive analysis is carried out on the bio-crude and upgraded fuel to investigate its fuel properties and the fate of nitrogen and oxygen following hydrotreatment. This investigation is the first to study fast heating rate, low residence time continuous HTL of microalgae and subsequent upgrading of bio-crude to a refinery ready feedstock. Further novel results and discussion is presented on the high molecular weight fraction of bio-crudes and upgraded oils using pyrolysis gas-chromatography mass-spectrometry (Py-GC-MS) to elucidate the fate of nitrogen and oxygen during continuous HTL and hydroprocessing.

2. Materials and methods

Chlorella (cell walls intact, 80–120 mesh) microalgae was obtained from Sunrise Nutrachem Group, Qingdao Sunrise Trading Co., Ltd. (China). Experimental procedures for the determination of ash, moisture, CHNSO content and biochemical composition were determined as described previously [29]. Cobalt molybdenum and nickel molybdenum on alumina catalysts (1–2 mm size) were provided by Johnson Matthey (London, UK). Chemicals and reagents were obtained from Sigma-Aldrich (dichloromethane, kerosene, dimethyldisulfide, tetrahydrofuran (THF), pentane).

The continuous HTL reactor was custom built at the University of Leeds. Its schematic layout is presented in Fig. 1. All piping is made of 316 SS Swagelok 0.6335 mm outer diameter, 0.0899 mm wall thickness tubes. The reactor is submerged into a FSB 3 Fluidised Sand Bath (Omega Engineering, USA). The reactor is made of 4 coils of 1.5 m length (98 mL total volume) connected in series and fully submerged in hot fluidised sand. The microalgae feed slurry was prepared by mixing 10 wt.% dry *Chlorella* microalgae with distilled water using a domestic food mixer. The slurry was kept in a pre-mixed beaker using a magnetic stirrer to obtain uniform solids concentrations throughout the experimental runs. A head pressure of 0.06 bar from the mixing chamber to the pump was sufficient to provide feed for the high pressure pump. A Series 900 hydraulic diaphragm metering pump from Aquflow (Irvine, CA, USA) was used to pump the slurry and obtain the required pressure

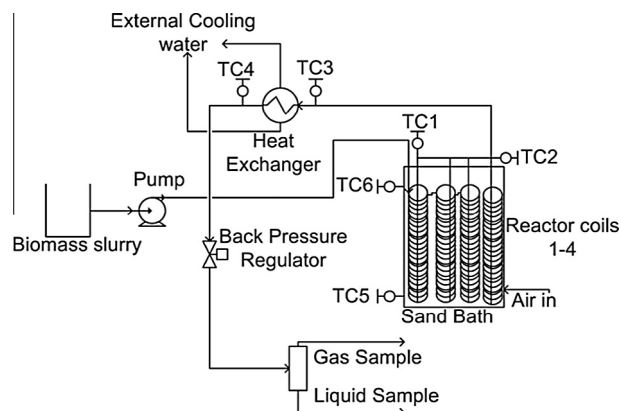

Fig. 1. Schematic layout of the continuous HTL reactor.

to keep the water in its liquid state. The pump is capable of pressures up to 206 bar and flow rates of 24.6 l/h although at operating conditions of 185 bar the pump was only able to reach a maximum flow of 2.5 l/h. To achieve the required pressure for the water to stay in its liquid state we used a Swagelok KPB backpressure regulator. This was manually adjusted with the aid of a Gems (Plainville, CT, USA) Series 3100/3200 Compact High Pressure OEM pressure transmitter with digital readings on a PC. A further 1.5 m coil was installed as a heat exchanger before the back pressure regulator. It was submerged in a custom built water tank connected to a recirculating water bath set to 65 °C. The temperature of the reactants was measured using a 1 mm o.d. K-type thermocouples fitted inside the reactor tubes. Thermocouples were placed after the first reactor coil, after the fourth reactor coil, before the heat exchanger and pressure transducer, after the heat exchanger and at the top and bottom of the sand bath (see Fig. 1). The reactor contents were collected in 2 l separating funnels. The bio-crude, solids and water phase were mixed with dichloromethane at approximately 2 parts DCM to 10 parts water/bio-crude. After vigorous shaking the organic DCM fraction was collected separately from the aqueous and solid fractions. DCM was evaporated from the bio-crude using a rotary vacuum evaporator at room temperature. Finally the bio-crude was stored in a fridge for further processing and analysis.

HTL reactions were carried out at 350 °C and flow rates of 10 mL/min and 40 mL/min. The flow rates were measured manually once the reactor had reached reaction conditions using a stopwatch and measuring cylinder at the output of the system after the back pressure regulator. The flow rates were used to calculate the residence times in the reactor (volume 98 mL). As the density of water reduces at 350 °C and ~180 bar to 0.59 g/cm³ the residence time in the reactor is calculated to be approximately 5.8 and 1.4 min respectively but this does not take into account the time to reach the temperature of 350 °C while flowing through the reactor during which the density gradually decreases. The temperature was reached to within 4 °C of the 350 °C set point temperature after the first reactor coil. This equates to approximately 0.35 min and 1.4 min heat up time at flow rates of 40 and 10 mL/min respectively although this is only an approximation using the residence time calculated based on the water density at the final temperature of 350 °C, this density is in fact not constant. Post reactor, the temperature reduced to around 300 °C before reaching the heat exchanger where the reactants are cooled to 65 °C in a cooling coil of 24.5 mL in approximately 2.1 and 0.5 min. The heating rates were therefore 915 and 230 °C/min and the cooling rates were approximately 470 and 112 °C/min at the fast and slow flow rates respectively.

Hydroprocessing was carried out at the Illinois Sustainable Technology Center, USA. For each batch experiment, approximately 25 g of bio-crude and 5 g of catalyst (20 wt.%) were placed in a Parr high pressure reactor (Model 4575A, Parr Instruments, IL, US). The reactor had a volume of 500 mL and a maximum working pressure of 5000 psi. Temperature was controlled using a PID controller (Model 4848, Parr Instruments, IL, US). The reactor was stirred continuously and heated to either 350 or 405 °C. Prior to the experiments the reactor was purged with N₂ twice and thrice with H₂, the initial H₂ pressure was adjusted to approximately 60 or 66 bar. The ideal gas law was used to calculate a final operating pressure of 138 bar at operating temperature. The heating rate of the reactor was approximately 5–7 °C/min, once the operating temperature was reached, the temperature was held for 2 h. Upon completion of the reaction, the reactor was cooled using cooling coils inside the reactor, the cooling rate was approximately 15 °C/min. The final gas pressure and temperature were recorded and vented. NiMo reactions at 405 °C were carried out in triplicate and in duplicate for 350 °C. The CoMo upgrading at 405 °C was

carried out in duplicate and only once at 350 °C. The reactor contents were recovered and separated (upgraded oil, catalyst, coke and water), only the upgraded oil fraction was quantified. DCM was used to recover the remaining oil on the reactor walls, the catalysts and stirrer following which the DCM was evaporated. The fraction recovered without DCM was used for further analysis. Both parts were combined to determine the yield of upgraded bio-crude.

The CoMo and NiMo catalysts were sulfided prior to use. 25 g of catalyst was heated in the Parr stirred reactor under a hydrogen atmosphere together with 75 mL of 2 wt.% dimethyldisulfide in kerosene. The reactor was purged with N₂ twice and thrice with H₂, the initial H₂ pressure was adjusted to approximately 38 bar. Under continuous stirring the reactor temperature was held initially for 2 h at 40 °C, ramped in 15 min to 150 °C, held for 8 h, ramped in 15 min to 270 °C, held for 8 h, ramped in 15 min to 300 °C, held for 8 h, finally the temperature was reduced to ambient. The catalysts were separated from the kerosene solution, washed with DCM to remove residual kerosene, dried under N₂ and stored in a N₂ atmosphere before further use.

The bio-crude from HTL and upgraded bio-crude from hydroprocessing was analysed by ultimate analysis, GC–MS and simulated distillation. Samples were processed for total CHN (carbon/hydrogen/nitrogen) using an Exeter Analytical (Chelmsford, MA) CE-440 Elemental Analyzer, the oxygen content was calculated by difference. Sulphur was measured by ICP–OES in axial mode (PerkinElmer Optima 2000DV) after digesting samples (PerkinElmer Multiwave 3000 Digester). The HHV was determined using the DuLong formula based on the CHNSO analysis. GC–MS analysis was carried out using a Shimadzu 2010 GC–MS instrument (Shimadzu Corporation, Kyoto, Japan). 1 wt.% solutions of bio-crude in DCM were prepared and 5 µl injected. The split/splitless injector was set to 280 °C and a split ratio of 10:1 was used. The products were separated on an Rtx 1701 column (60 m × 0.25 mm i.d., 0.25 µm film thickness) using a temperature program of 60 °C (2 min) to 280 °C (held 10 min) at 5 °C/min and a constant column head pressure of 2.07 bar. The ion source was at 230 °C and the interface 280 °C, with a scan rate of 1 s over *m/z* 50–550. Peaks were assigned using the NIST mass spectral database.

The boiling point distribution of oil samples was obtained by performing simulated distillations according to ASTM 7169. The analysis was performed on 1% (w/w) sample solutions in dichloromethane using an HP 5890 Series II FID gas chromatograph equipped with a temperature programmed vaporizer injector, HP 7673 autosampler, and a Durabond DB-HT-SimDis column by Agilent J&WScientific (5 m × 0.53 mmid, 0.15 µm film) as described by Vardon et al. [31,32].

Bio-crude samples and hydroprocessed oils were solvent extracted using n-pentane at room temperature. Approximately 5 g of bio-crude was continuously stirred using a magnetic stirrer at a ratio of 40:1 pentane:oil (wt.) in a 500 ml conical flasks for 24 h. Subsequently the solution was vacuum filtered through Whatman glass sintered filters. Pyrolysis–gas chromatography–mass spectrometry (Py-GC–MS) was carried on the pentane in-soluble fraction as described previously [29].

3. Results and discussion

3.1. Continuous HTL

Our research into continuous HTL of microalgae investigated the use of a relatively low lipid level strain of *Chlorella* sp. The elemental composition and biochemical analysis is presented in Table 1. The strain has a relatively high protein content of

Table 1
Chlorella sp. feedstock analysis: ultimate, proximate and biochemical composition.

C	H	N	S	O	HHV	Protein	Carbohydrate	Lipid	Ash	Moisture
(wt.% daf)					(MJ/kg)	(wt.% daf)		(wt.%)		
56.2	6.9	7.7	0.6	28.7	19.9	45.8	36.4	14.5	11.7	4.4

45.8 wt.% and low lipid content of 14.5 wt.%, resulting in a high algal nitrogen content of 7.7 wt.%. One of the advantages of hydrothermal liquefaction is the ability to process low lipid content biomass which would not be feasible for lipid extraction technologies. Growing microalgae with high lipid content is often achieved in the detriment of growth rate, resulting in lower growth yields [33]. Additionally, the use of waste water as a nutrient source introduces challenges for controlling the exact nutrient conditions required for high lipid productivity. The integration of algal cultivation and waste water treatment and/or nutrient recycling is generally agreed to be more economically viable than growing strains in controlled environment for optimum lipid accumulation [34]. It has previously been shown in several studies that HTL can produce bio-crude from the carbohydrate and protein fraction as well as the lipids [35,36]. Teri et al. recently presented a model for the bio-crude yield prediction based on biochemical composition of algae [36]. It shows that bio-crude yields are heavily influenced by the biochemical composition of microalgae and proteins in particular, contribute significantly to bio-crude formation. Therefore in this study we have chosen an algal strain with low lipid and high protein content, however it should be noted that high lipid containing alga with low N content result in high yields of bio-crude with lower N content.

HTL of *Chlorella* was carried out at 350 °C, 10 wt.% solids concentration and two residence times. Bio-crude yields, elemental composition, HHV and energy recovery are presented in Table 2. The continuous HTL reactor was operated on 14 separate days. During a typical experiment the reactor ran for approximately 2 h to reach steady state by pumping distilled water at 185 ± 10 bar continuously and reaching 350 ± 5 °C. At this point the feed was switched to 10 wt.% algae slurry for approximately 3 h, before cooling the reactor back down to ambient temperature. The reactor was operated for about 50 h continuously over the course of the investigation using algae slurry. The experiments at the higher flow rate of 40 mL/min were repeated on four days while the 10 mL/min operating condition was employed for the remaining days. Experimental variations of bio-crude yields were low with ~1 wt.%. A maximum bio-crude yield of 39.7% was obtained at the higher flow and lower residence time of 1.4 min. Similar results were observed for continuous HTL of *Chlorella* and *Spirulina* by Jazrawi et al. [27]. The bio-crude yield reduced to 36.8% at 5.8 min residence time. This observation is in agreement with batch results presented by Faeth et al. who investigated the fast hydrothermal liquefaction of *Nannochloropsis* [28]. Their study showed a maximum bio-crude yield of 66 wt.% at a heating rate of ~300 °C/min and residence time of 1 min, showing that low residence times and high heating rates led to maximum bio-crude yields and energy recoveries. Therefore the potential exists of achieving higher bio-crude yields on our continuous reactor by

Table 2
 Bio-crude yields, ultimate analysis of bio-crude and energy recovery to bio-crude.

Residence time	Bio-crude yield	C	H	N	S	O	HHV	Energy recovery
Min	(wt.% daf)	(wt.%)					(MJ/kg)	(%)
1.4	39.7	68.0	8.9	6.1	0.8	16.2	32.9	54.9
5.8	36.8	72.8	9.4	6.0	0.8	11.1	36.1	55.8

further decreasing the residence time. It is still unclear if the higher yields are due to increased heating and cooling rates or the short residence times. We aim to investigate this in future studies by either adjusting the flow rate (higher heating rate) or by adjusting the reactor coil lengths (residence time).

Despite the similarity in bio-crude yields, the HHVs differ significantly. The longer residence time operating conditions' bio-crude has a lower oxygen and higher carbon content, leading to an increased HHV. The oxygen content of the bio-crudes is clearly affected by the varying residence times reducing from 16% to 11% and a minor reducing in N is also observed. This is in agreement with HTL batch results by Faeth et al. who observed a reduction in O content from 12% to 8% with increasing residence time from 10 to 90 min [28]. This means that the quality of the bio-crude is superior at the longer residence times and more suitable for upgrading due to lower H₂ demand for hydro-deoxygenation despite the lower yield. The increased HHV at longer residence time results in a higher chemical energy recovery to the bio-crude from the algae feedstock. A maximum energy recovery of 55.8% was obtained at the longer residence time. As the residence time decreases by increasing the flow rate, the reactor output increases and energy requirements decrease. This reduces the capital cost of the continuous system and could improve the energy balance by improving the net energy return. As the chemical energy recovery is reduced however at the lower residence time, the optimum conditions for continuous HTL need to be carefully adjusted. The effect of this trade-off should become more apparent with the transition from lab scale to pilot and full scale HTL systems. Careful consideration should be given to flow rates, heating rates and residence times in terms of bio-crude yield, chemical energy recovery, capital reactor cost and energy requirements.

The current study differs from the study by Elliott et al. who did not employ the use of solvents to recover the bio-crude. This has two advantages over the methodology in the current study; firstly it avoids the use of toxic solvents which incur cost and can be harmful and secondly it can diminish the quality of bio-crude. Xu and Savage demonstrated in a batch HTL study the effect of using DCM for the recovery of bio-crude [30]. It was shown that additional bio-crude is recovered from the aqueous phase compared to using no solvents. This accounted to about 8% of the total bio-crude. There were also remarkable differences between the bio-crude recovered from the aqueous phase to the bio-crude which was recovered directly without DCM. The O and N contents were found to be twice as high, adding additional N and O to the bio-crude when recovered using DCM from all product phases, thereby diminishing its quality. The study by Elliott et al. did not use a solvent to recover bio-crude which could be one of the reasons for the higher O and N contents observed in the current study (O = 11–16%; N = 6%) compared to theirs (O = 5–8%, N = 4–5%) [21].

3.2. Hydro-processing

The process water and bio-crude mixture from HTL was separated as outlined in the methodology, the solid residue and gas phases were not quantified. We used the bio-crude from the longer residence time and lower flow rate for further investigation. All subsequent upgrading experiments and analysis were carried out on the bio-crude from 5.8 min residence time. Hydroprocessing

Table 3
Ultimate analysis of upgraded bio-oil (%), yields and higher heating value (HHV) in MJ/kg.

	Yield (wt.%)	C	H	N	S	O ^a	HHV
<i>No catalyst</i>							
350 °C	94.8	79.6	10.8	4.7	0.117	5.0	41.5
405 °C	68.9	83.5	11.3	3.6	0.072	1.5	44.7
<i>NiMo catalyst</i>							
350 °C	93.1	80.4	10.5	4.7	0.206	4.2	41.5
405 °C	41.0	84.5	11.6	2.4	0.002	1.5	44.9
<i>CoMo catalyst</i>							
350 °C	89.0	79.4	10.9	4.6	0.420	4.7	41.6
405 °C	69.4	84.4	11.9	2.7	0.000	1.0	45.4

^a Calculated by difference.

of the bio-crude was carried out at temperatures of 350 and 405 °C and a constant residence time of 2 h in a batch reactor. The yields of hydroprocessed bio-crude are listed in Table 3. The upgraded bio-crudes were found to be completely free flowing at room temperature and lighter in colour compared to the original bio-crude. At the lower temperature of 350 °C, high yields of upgraded bio-crude were obtained of 95%, 93% and 89% for no catalyst, NiMo and CoMo catalysed reactions respectively. The yields are significantly higher at the lower operating conditions compared to yields of only 69%, 41% and 69% at 405 °C for no catalyst, NiMo and CoMo respectively. Elliott et al. hydroprocessed the bio-crude from four different microalgae at 405 °C using a sulfided CoMo on alumina catalyst and obtained a refined oil yield of 80–85% [21]. Li and Savage hydrotreated algal bio-crude over HZSM-5 catalysts at 400, 450 and 500 °C. They were able to achieve upgraded oil yields of 75%, reducing at the higher temperatures to 42% [16]. Bai et al. investigated the use of 15 different heterogeneous catalysts for hydrothermal algal bio-crude upgrading. Their results show an upgraded oil yield of 55–77% at 400 °C, highest yields were achieved using a combination of Ru/C and Raney/Ni, the yield using a Co/Mo catalyst were 65%. Bai et al. present a full mass balance on their upgrading experiments with the gaseous product fraction ranging from 7% to 14%, 14% to 29% coke and small amounts of water soluble products and losses. Similarly we observed water and coke formation in our experiments although these fractions were not quantified.

Table 3 also presents the elemental analysis of the upgraded bio-crude and the calculated HHV. The carbon content in the upgraded oil ranges from 79 to 85 wt.%, increased from 73 wt.% in the bio-crude, small increases in H were also observed. Reductions in N, O and S were more pronounced at the higher operating temperature for all reactions. NiMo at 405 °C resulted in the lowest N content of 2.4%, this value is in the range of values observed in the studies by Bai et al. (2014) and Li and Savage (2013). Elliott et al. were able to reduce the N content in their upgraded bio-crude to values as low as 0.05% [21]. This group are the only one to have investigated the use of a continuous flow catalytic fixed bed reactor, while all other studies used batch reactors. The improved catalytic mass

transfer in such a reactor could be the reason for the higher hydro-denitrogenation of bio-crude. Our results show that up to 84% of N is removed via catalytic hydro-denitrogenation for NiMo catalysts 69% for the CoMo catalyst and 58% without the use of a catalyst on a mass basis, taking the yields into consideration. Low oxygen contents were calculated for the upgraded oils at 405 °C of 1.0–1.5%, comparable to those observed by Elliott et al. [21] and, on average, lower to those of Bai et al. [20]. The lowest oxygen content was observed for the CoMo catalysed reaction at 405 °C while the NiMo and un-catalysed reactions were equally effective at de-oxygenation. However hydro-denitrogenation was more pronounced with the use of catalysts. The oxygen content of 1.0% found in the current study for the non-catalysed reaction is higher compared to the results obtained by Roussis et al. of 0.2% [38]. Desulphurisation was also more effective at higher temperatures for both catalysts; NiMo resulted in a final S content of 20 ppm and no sulphur could be detected using CoMo. Using the CHNS values measured, the HHV was calculated for the upgraded oils. Even at the lower temperature significant increases in HHV are observed compared to the 36.1 MJ/kg of the original bio-crude. Taking into consideration the high refined oil yield at 350 °C and the HHV of upgraded oil, energy recoveries in the upgraded fuel exceed 100%. This is due to the additional heating value of H₂ which was incorporated to the upgraded oils. A maximum HHV of 45.5 MJ/kg is presented for the upgraded oil at 405 °C and CoMo catalyst. Overall the results show the good performance of the catalysts in terms of de-oxygenation and desulphurisation; however hydro-denitrogenation is still relatively low. The results also show good performance for the non-catalysed reactions in terms of yields and de-oxygenation at 405 °C but the N content is still quite high. The hydrogen consumption for each hydrotreating run was calculated based on the initial H₂ pressure and after the reactor had cooled back to ambient. This is an oversimplification as there are other gases produced during the process, as analysed by Elliott et al. The gases detected were mainly ammonia, methane and ethane [21]. Bai et al. show that on average approximately 10 wt.% of the bio-crude is converted into gas. Using these assumptions we calculated indicative values of H₂ consumption from 0.012 to 0.029 kg/kg bio-crude. These values are lower compared to Zhu et al.'s reported value of 0.05 kg/kg [37]. Our values are lower as we did not see complete hydro-denitrogenation and hydrodeoxygenation of the bio-crude. Stoichiometric calculations, assuming all N is removed via NH₃, O via H₂O and S via H₂S, and neglecting the H₂ consumption for saturating bonds and hydrocracking, result in a theoretical H₂ consumption of 0.035 kg/kg for the HTL bio-crude used in the current study.

3.3. Oil analysis

Sim-Dis analysis was carried out to investigate the boiling point distribution of the catalytically hydrotreated bio-crudes and is compared in Table 4 to the untreated bio-crude. The five distillate fractions are defined as gasoline (<190 °C), diesel cuts 1 and 2 (190–290 °C and 290–340 °C), vacuum gas oil (340–538 °C) and vacuum residue above 538 °C. The original material shows a large fraction in the heavy molecular weight, high boiling point,

Table 4
Sim-Dis analysis of bio-crude and upgraded bio-oil.

Cut name	Temperature range	Bio-crude % Fraction	NiMo 350 °C	NiMo 405 °C	CoMo 350 °C	CoMo 405 °C
Gasoline	<190 °C	3	6	24	7	24
Diesel #1	190–290 °C	9	18	38	21	40
Diesel #2	290–340 °C	18	11	12	12	14
Vac gas oil	340–538 °C	56	42	18	42	17
Vac residue	>538 °C	14	23	8	18	5

fractions of vac gas oil and vac residue, 70% of the material is found in these distillate fractions above 340 °C. Only 3% bio-crude is fractionated in the gasoline range, 9% in diesel 1% and 18% in diesel 2 cuts. Hydrotreating using NiMo catalysts resulted in doubling the gasoline and diesel 1 fractions but interestingly also increased the heaviest fraction, indicating that the heavy material is not efficiently cracked at 350 °C. At the higher temperature NiMo catalysed upgrading resulted in further increases in the gasoline and diesel 1 cuts and significant reductions in the two heaviest fractions. A total of 74% of the upgraded bio-crude at this condition is now fractionated in the gasoline and diesel fractions, compared to 30% in the bio-crude. The CoMo catalyst showed similar effects to NiMo, with the efficiency of cracking high boiling point material increasing at the higher hydroprocessing temperature. The most favourable result was obtained for CoMo at 405 °C with 24% gasoline, 40% and 14% diesel 1 and 2 cuts respectively. These results show that a high quality fuel can be produced by upgrading HTL bio-crude, with up to 78% yields of gasoline and diesel fractions. Taking into consideration the HTL and hydroprocessing conversion yields, this results in a total of 21% of the microalgae feedstock being converted to gasoline and diesel. This surpasses the lipid content of 14%, showing the potential of the HTL technology to

produce more bio-fuel compared to bio-diesel or green diesel technologies. However the N content of around 2.5% still poses a problem which would not be encountered in lipid extraction and conversion technologies.

Fig. 2 shows the GC–MS chromatograms of the HTL bio-crude and the hydrotreated oils using CoMo at 350 and 405 °C, as (a), (b) and (c) respectively. The untreated bio-crude reveals a complex mixture of numerous different compounds. As indicated in Fig. 2(a) these include hydrocarbons, nitrogen containing compounds and oxygenates. The nitrogen containing compounds are ring type structures with either two N atoms such as pyrazines, or one N atom such as pyrroles and indole. There are also long chain hydrocarbons with N and O groups present such as hexadecanamide and octadecanamide. The primary aim of hydroprocessing is to remove these O and N atoms to obtain pure hydrocarbons as well as hydrocracking high molecular weight compounds and saturating double bonds. Fig. 2(b) shows the chromatogram of hydroprocessed oil at 350 °C using CoMo catalyst. A larger abundance of aliphatic hydrocarbons ranging from C₁₁ to C₁₈ is apparent compared to the bio-crude. There are two additional alkanes with N groups present while the peak areas of hexadecanamide and octadecanamide have reduced. It is likely that hydroprocessing at these conditions

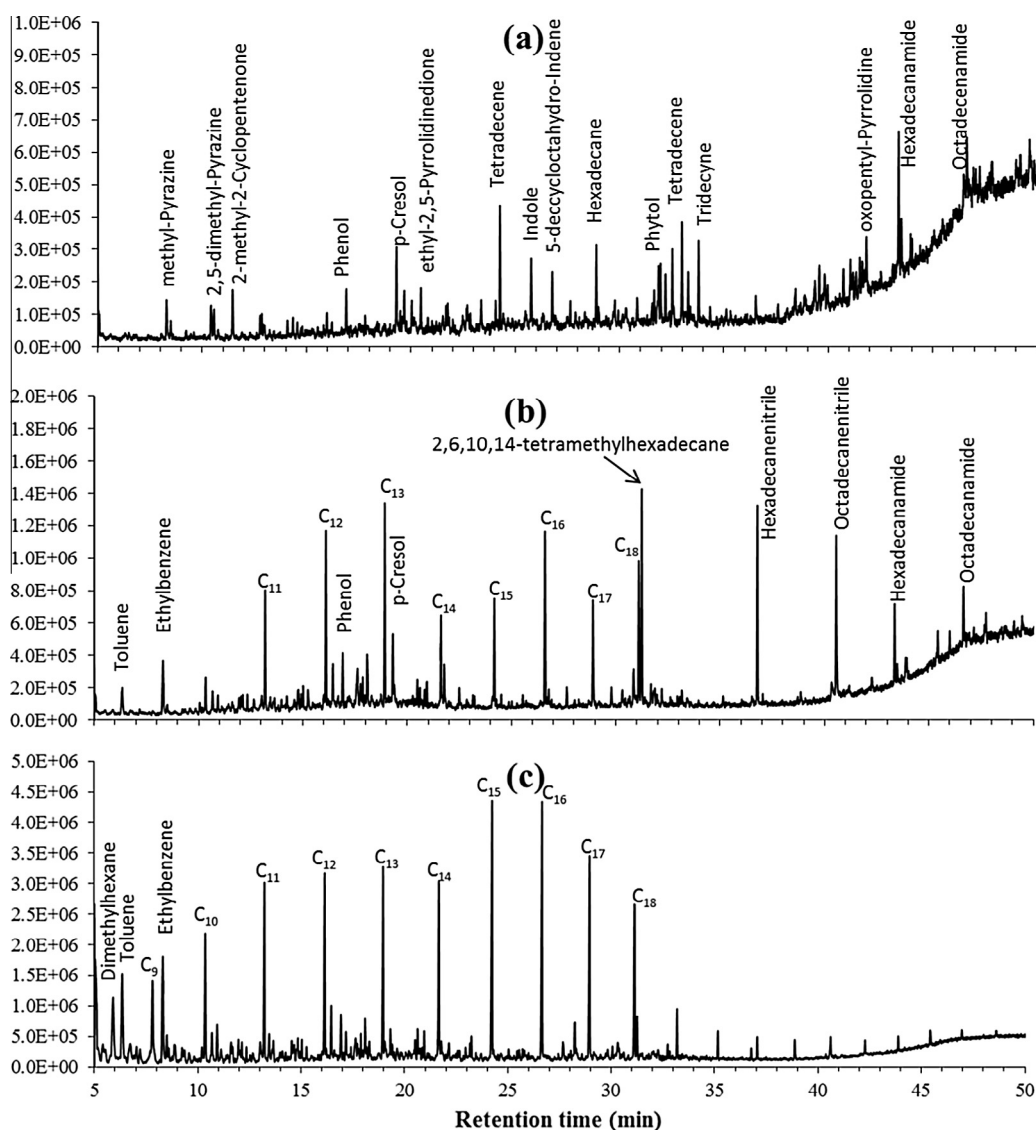

Fig. 2. TIC MS chromatograms of (a) bio-crude, (b) hydrotreated CoMo 350 °C oil and (c) hydrotreated CoMo 405 °C oil. Y-axes represent TIC intensity.

resulted in deoxygenation of these compounds to produce hexadecanenitrile and octadecanenitrile. Indole, the pyrazine and pyrrole compounds appear to be de-nitrogenated while the concentrations of the oxygenates, phenol and p-cresol, are not affected. There are two additional low molecular weight hydrocarbons present, toluene and ethylbenzene. These were also observed in the GC–MS analysis by Elliott et al. in their hydroprocessed algal bio-crude [21]. The chromatogram of the bio-crude hydroprocessed at 405 °C is presented in Fig. 2(c). This chromatogram reveals a spread of alkane hydrocarbons ranging from C₉ to C₂₆, with decreasing quantities of the longer chain alkanes. The most abundant alkanes observed are C₁₅ and C₁₆, with decreasing amounts present for longer and shorter chains. The only non-alkanes observed are toluene and ethylbenzene. It can be seen that all the N and O containing compounds still present at 350 °C are now fully hydrogenated to hydrocarbons. For example we were able to detect small amounts of indane (0.8% of total area) which is a likely product of hydro-denitrogenation of indole. We were not able to detect any O or N compounds in the 50 largest peaks identified in this chromatogram. This leads to the postulation that the bio-oil fraction separated and identified by GC–MS is very low in O and N even though the total N and O contents were 2.7% and 1% respectively (Table 3). The temperature range we were able to analyse via GC is from 60 to 280 °C. Sim-Dis results from Table 3 show that this represents around 65% of the entire upgraded oil. We therefore conclude that the majority of remaining O and N compounds after hydroprocessing bio-crudes using CoMo catalyst at 405 °C are found in the heavier, high boiling point fractions of the oil. This means that simple distillation of the upgraded bio-crude could lead to fuel cuts approaching diesel and jet fuel standards. In further investigations we aim to distil the upgraded oil into its respective fractions and carry out elemental analysis to confirm these conclusions. The chromatograms of the bio-crude hydrotreated using NiMo catalysts were found to be almost identical to the CoMo catalysed oils and are therefore not included. The un-catalysed reactions revealed a similar oil composition at the processing temperature of 405 °C but with additional peaks of hexadecanenitrile and octadecanenitrile which confirms the less efficient hydro-denitrogenation without the use of catalyst (Table 3). At 350 °C hydrotreating temperature without catalyst these types of compounds were found to be dominant in the chromatogram with two additional amide compounds identified. The GC–MS chromatograms of the hydrotreated bio-crudes without the use of catalysts are shown in the electronic Supplementary Fig. S1(a and b) for 350 and 405 °C.

As there were no N and O containing compounds observed in the GC–MS analysis of hydroprocessed bio-crudes for catalytic runs at 405 °C we performed further analysis to investigate the nature of the higher molecular weight bio-crude fraction which does contain N and O as shown in Table 3. Therefore we performed a solvent extraction using pentane to investigate if further reductions in N and O could be achieved and determine the composition of this high molecular weight asphaltenic material.

3.4. Fate of N and O

Despite the reductions in oxygen content and improved flowability of the hydrotreated bio-crudes, the nitrogen content was not reduced to a satisfactory level following hydroprocessing. Therefore pentane extraction was applied to fractionate the bio-crude and hydrotreated bio-crudes further into pentane soluble and pentane in-soluble fractions. This was performed in an effort to obtain low and high molecular weight fuel fractions and investigate the distribution of nitrogen and oxygen therein. Organic solvent extraction is a common technique in the petroleum refining industry to remove heavy, asphaltenic material

before upgrading in an effort to reduce catalyst poisoning [39]. Pentane extraction resulted to a solid, black residue and a free flowing fraction after evaporation of pentane. The yields of extraction are shown in Table 5; the pentane insoluble fraction is referred to as asphaltene. The HTL bio-crude resulted in approximately 50 wt.% asphaltene fraction exhibiting a nitrogen content of 7.5% compared to 6.1% in the initial feed, showing a slight concentration of nitrogen in the asphaltene fraction. The nitrogen and oxygen content of the C₅ soluble fraction was reduced to 4.5% and 6.4% respectively, demonstrating the preferential distribution of N and O to the asphaltene fraction. The bio-crude hydrotreated at 350 °C using CoMo catalyst led to 22% asphaltene content while this fraction was reduced to only 2% at the higher hydrotreating temperature of 405 °C. The oxygen contents of both pentane soluble fractions of hydrotreated bio-crudes were calculated by difference and indicated that all oxygen had been removed. This shows that solvent extraction can remove additional oxygen after hydrotreating. However the nitrogen content of the pentane soluble oils at 350 °C and 405 °C hydrotreating still contain 4.1% and 2.7% nitrogen. Although a slight increase in nitrogen content in the asphaltene residues at these conditions was observed, the fractioning of nitrogen using pentane is not effective.

The results in Table 5 raise the question why hydrotreating does not remove more nitrogen from the bio-crudes at the conditions investigated using the current batch reactor set-up. It can be expected that very condensed and high molecular weight polymers containing nitrogen and oxygen are not as easily hydrogenated. The pentane extraction was able to show a slight concentration of nitrogen and complete concentration of oxygen in the asphaltene fraction. In order to obtain additional information about the molecular structure of the asphaltene fraction, and a possible explanation to the difficulties in catalytic hydrotreating, pyrolysis–gas chromatography–mass spectrometry was performed on the asphaltene residues at temperatures of 500, 600, 800, 1000 and 1200 °C. Table 6 shows the relative amount of material released as volatiles upon pyrolysis of the asphaltene residue from hydrotreated bio-crude at 405 °C (CoMo catalyst). The values show that only 45% of the residue is released at 1000 °C and 70% at the highest temperature of 1200 °C suggesting the asphaltene fraction is prone to coking. This demonstrates the high thermal stability of the asphaltene residue up to 1200 °C.

Fig. 3 shows the pyrograms from the C₅ residues (CoMo 405 °C) pyrolysed at 600 °C. The majority of the peaks are of aliphatic nature (triangles in Fig. 3), including very short alkane/-enes eluting before 5 min retention time. Butene, pentene, hexene, pentadiene, heptane and cyclopentadiene all elute before benzene (5 min) on

Table 5
Asphaltene yields following C₅ extraction, nitrogen and oxygen concentrations.

	Asphaltene content (%)	N content asphaltene (%)	N content C ₅ solubles (%)	O content C ₅ solubles (%) ^a
Bio-crude	51.4	7.5	4.5	4.5
CoMo 350 °C	21.8	6.5	4.1	0
CoMo 405 °C	2.0	6.0	2.7	0

^a Calculated by difference.

Table 6
Percentage (wt.) of residue pyrolysed from C₅ extract of hydrotreated bio-crude at 405 °C (CoMo).

Pyrolysis temp (°C)	% wt. residue pyrolysed
500	13.0
600	44.8
800	46.7
1000	47.4
1200	70.4

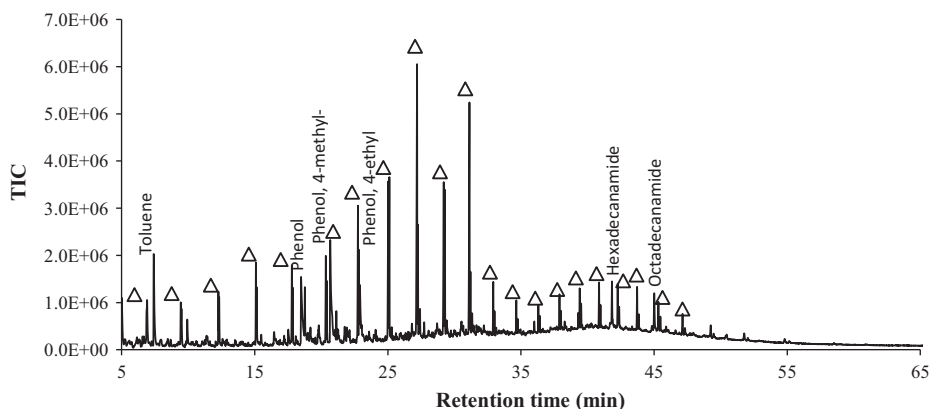

Fig. 3. Pyrogram of C₅ residues (CoMo 405 °C bio-crude) at 600 °C Δ = alkene/-anes.

the GC chromatogram and make up 9% of the entire chromatogram area. Aromatic compounds observed include phenols, toluene and benzenamines, comprising 21% of the chromatogram area. The nitrogen containing compounds identified include benzenamines and long chain fatty acid amides. The vast majority of pyrolysis products at 600 °C pyrolysis temperature are of aliphatic nature, comprising approximately 77% of the total area. There are also oxygenates identified, namely phenols which make up a 15% of the chromatogram area, explaining the deoxygenation of the pentane soluble fraction. The oxygen containing phenol peaks at 500 °C were found to be 60% of the entire chromatogram area, showing the distribution of oxygen compounds in lower boiling point material. Non-oxygenated aromatics at 500 °C were only 1% compared to 4% at 600 °C and 7% at 700 °C. This fraction steadily increased but aromatisation reactions during pyrolysis could explain their occurrence rather than there being poly-aromatic material present in the asphaltene. Due to the thermal stability of the asphaltene fraction shown in Table 6 it can be expected this fraction is difficult to hydro-crack and hydrogenate to lower molecular weight hydrocarbons. The N containing compounds revealed in Fig. 3 are amides which are also shown in Fig. 2(b) and were successfully hydro-treated in Fig. 2(c). Their occurrence in the asphaltene fraction could be due to being linked to condensed structures in the bio-crude which are not cracked at the hydrotreating conditions.

The presence of the amide and nitrile compounds in the pyrograms even after hydrotreating at 405 °C suggests they could be linked to other material, possibly aromatic structures, and require higher cracking temperatures before these can be cleaved and hydrotreated. We therefore suggest that hydrotreating of bio-crudes either requires higher temperatures (which will result in reduced yields due to additional volatile products) or otherwise a solvent extraction can be carried out initially to remove some of these condensed, nitrogen and oxygen containing structures. This will also result in a reduced yield but could potentially allow lower hydrotreating temperatures. Further studies will focus on identifying suitable solvents for improved separation of nitrogen in the oil fractions and investigate the use of a continuous fixed bed catalytic reactor to investigate if limited mass transfer was the reason for incomplete hydro-denitrogenation.

4. Conclusions

Microalgae slurry was successfully processed in a continuous hydrothermal liquefaction reactor at 10 wt.% concentrations, temperature of 350 °C and residence times of 1.4–5.8 min. Bio-crude yields were higher at the lower residence time but exhibited higher O and N levels, resulting in higher energy recoveries at 5.8 min residence time. Catalytic (NiMo and CoMo) and non-catalytic

hydroprocessing of the bio-crude led to a free flowing oil with reductions in O, N and S of the bio-crude and a maximum HHV of 45.4 MJ/kg. Our results show that 20% of algae feedstock can be converted into high quality gasoline and diesel, surpassing its lipid content.

Acknowledgments

The authors would like to thank the Royal Society of Chemistry, UK for the award of the JWT Jones Travelling Fellowship to P. Biller to carry out this collaborative research at the Illinois Sustainable Technology Center, USA. The authors would also like to thank the EPSRC (EP/I014365/1), for financial support and the Doctoral Prize Fellowship for P. Biller (EP/L504993/1).

Appendix A. Supplementary material

Supplementary data associated with this article can be found, in the online version, at <http://dx.doi.org/10.1016/j.fuel.2015.06.077>.

References

- [1] Balasundaram B, Skill SC, Llewellyn CA. A low energy process for the recovery of bioproducts from cyanobacteria using a ball mill. *Biochem Eng J* 2012;69:48–56.
- [2] Pienkos PT, Darzins A. The promise and challenges of microalgal-derived biofuels. *Biofuels, Bioprod Biorefin* 2009;3:431–40.
- [3] Jena U, Das KC, Kastner JR. Effect of operating conditions of thermochemical liquefaction on biocrude production from *Spirulina platensis*. *Bioresour Technol* 2011;102:6221–9.
- [4] Brown TM, Duan P, Savage PE. Hydrothermal liquefaction and gasification of *Nannochloropsis* sp. *Energy Fuel* 2010;27:1391–8.
- [5] Torri C, Garcia Alba L, Samori C, Fabbri D, Brilman DWF. Hydrothermal treatment (HTT) of microalgae: detailed molecular characterization of HTT oil in view of HTT mechanism elucidation. *Energy Fuel* 2012;26:658–71.
- [6] Eboibi BE, Lewis DM, Ashman PJ, Chinnasamy S. Effect of operating conditions on yield and quality of biocrude during hydrothermal liquefaction of halophytic microalga *Tetraselmis* sp. *Bioresour Technol* 2014;170:20–9.
- [7] Biller P, Ross AB. Hydrothermal processing of algal biomass for the production of biofuels and chemicals. *Biofuels* 2012;3:603–23.
- [8] López Barreiro D, Prins W, Ronsse F, Brilman W. Hydrothermal liquefaction (HTL) of microalgae for biofuel production: state of the art review and future prospects. *Biomass Bioenergy* 2013;53:113–27.
- [9] Tian C, Li B, Liu Z, Zhang Y, Lu H. Hydrothermal liquefaction for algal biorefinery: a critical review. *Renew Sust Energy Rev* 2014;38:933–50.
- [10] Frank E, Elgowainy A, Han J, Wang Z. Life cycle comparison of hydrothermal liquefaction and lipid extraction pathways to renewable diesel from algae. *Mitig Adapt Strateg Glob Change* 2012;1–22.
- [11] Jones SB, Zhu Y, Anderson DB, Hallen RT, Elliott DC, Schmidt AJ, Albrecht KO, Hart TR, Butcher MG, Drennan C, Snowden-Swan LJ, Davis R, Kinchin C. Process design and economics for the conversion of algal biomass to hydrocarbons: whole algae hydrothermal liquefaction and upgrading. Pacific Northwest National Laboratory; 2014. Available at: <<http://www.osti.gov/scitech/biblio/1126336>>.
- [12] Delrue F, Li-Beisson Y, Setier PA, Sahut C, Roubaud A, Froment AK, et al. Comparison of various microalgae liquid biofuel production pathways based

- on energetic, economic and environmental criteria. *Bioresour Technol* 2013;136:205–12.
- [13] Liu X, Saydah B, Eranki P, Colosi LM, Greg Mitchell B, Rhodes J, Clarens AF. Pilot-scale data provide enhanced estimates of the life cycle energy and emissions profile of algae biofuels produced via hydrothermal liquefaction. *Bioresour Technol* 2013;148:163–71.
- [14] Duan P, Savage PE. Hydrothermal liquefaction of a microalga with heterogeneous catalysts. *Ind Eng Chem Res* 2010;50:52–61.
- [15] Ross AB, Biller P, Kubacki ML, Li H, Lea-Langton A, Jones JM. Hydrothermal processing of microalgae using alkali and organic acids. *Fuel* 2010;89:2234–43.
- [16] Li Z, Savage PE. Feedstocks for fuels and chemicals from algae: treatment of crude bio-oil over HZSM-5. *Algal Res* 2013;2:154–63.
- [17] Duan P, Savage PE. Upgrading of crude algal bio-oil in supercritical water. *Bioresour Technol* 2011;102:1899–906.
- [18] Duan P, Savage PE. Catalytic hydrotreatment of crude algal bio-oil in supercritical water. *Appl Catal B: Environ* 2011;104:136–43.
- [19] Duan P, Savage PE. Catalytic treatment of crude algal bio-oil in supercritical water: optimization studies. *Energy Environ Sci* 2011;4:1447–56.
- [20] Bai X, Duan P, Xu Y, Zhang A, Savage PE. Hydrothermal catalytic processing of pretreated algal oil: a catalyst screening study. *Fuel* 2014;120:141–9.
- [21] Elliott DC, Hart TR, Schmidt AJ, Neuenschwander GG, Rotness LJ, Olarte MV, et al. Process development for hydrothermal liquefaction of algae feedstocks in a continuous-flow reactor. *Algal Res* 2013;2:445–54.
- [22] Elliott DC. Historical developments in hydroprocessing bio-oils. *Energy Fuel* 2007;21:1792–815.
- [23] Elliott DC, Biller P, Ross AB, Schmidt AJ, Jones SB. Hydrothermal liquefaction of biomass: developments from batch to continuous process. *Bioresour Technol* 2015;178:147–56.
- [24] Biller P, Ross AB, Skill SC, Lea-Langton A, Balasundaram B, Hall C, et al. Nutrient recycling of aqueous phase for microalgae cultivation from the hydrothermal liquefaction process. *Algal Res* 2012;1:70–6.
- [25] Garcia Alba L, Torri C, Fabbri D, Kersten SRA, Brilman DWF. Microalgae growth on the aqueous phase from hydrothermal liquefaction of the same microalgae. *Chem Eng J* 2013;228:214–23.
- [26] Jena U, Vaidyanathan N, Chinnasamy S, Das KC. Evaluation of microalgae cultivation using recovered aqueous co-product from thermochemical liquefaction of algal biomass. *Bioresour Technol* 2011;102:3380–7.
- [27] Jazrawi C, Biller P, Ross AB, Montoya A, Maschmeyer T, Haynes BS. Pilot plant testing of continuous hydrothermal liquefaction of microalgae. *Algal Res* 2013;2:268–77.
- [28] Faeth JL, Valdez PJ, Savage PE. Fast hydrothermal liquefaction of *Nannochloropsis* sp. To produce biocrude. *Energy Fuel* 2013;27:1391–8.
- [29] Biller P, Ross AB. Pyrolysis GC–MS as a novel analysis technique to determine the biochemical composition of microalgae. *Algal Res* 2014;6:91–7.
- [30] Xu D, Savage PE. Characterization of biocrudes recovered with and without solvent after hydrothermal liquefaction of algae. *Algal Res* 2014;6:1–7.
- [31] Vardon DR, Sharma BK, Blazina GV, Rajagopalan K, Strathmann TJ. Thermochemical conversion of raw and defatted algal biomass via hydrothermal liquefaction and slow pyrolysis. *Bioresour Technol* 2012;109:178–87.
- [32] Vardon DR, Sharma BK, Scott J, Yu G, Wang Z, Schideman L, et al. Chemical properties of biocrude oil from the hydrothermal liquefaction of *Spirulina* algae, swine manure, and digested anaerobic sludge. *Bioresour Technol* 2011;102:8295–303.
- [33] Adams C, Godfrey V, Wahlen B, Seefeldt L, Bugbee B. Understanding precision nitrogen stress to optimize the growth and lipid content tradeoff in oleaginous green microalgae. *Bioresour Technol* 2013;131:188–94.
- [34] Lundquist TJ, Woertz IC, Quinn N, Benemann JR. A realistic technology and engineering assessment of algae biofuel production. *Energy Biosci Inst* 2010;1.
- [35] Biller P, Ross AB. Potential yields and properties of oil from the hydrothermal liquefaction of microalgae with different biochemical content. *Bioresour Technol* 2011;102:215–25.
- [36] Teri G, Luo L, Savage PE. Hydrothermal treatment of protein, polysaccharide, and lipids alone and in mixtures. *Energy Fuel* 2014;28:7501–9.
- [37] Zhu Y, Albrecht KO, Elliott DC, Hallen RT, Jones SB. Development of hydrothermal liquefaction and upgrading technologies for lipid-extracted algae conversion to liquid fuels. *Algal Res* 2013;2:455–64.
- [38] Roussis SG, Cranford R, Sytkovetskiy N. Thermal treatment of crude algae oils prepared under hydrothermal extraction conditions. *Energy Fuel* 2012;26:5294–9.
- [39] Babich IV, Moulijn JA. Science and technology of novel processes for deep desulfurization of oil refinery streams: a review. *Fuel* 2003;82:607–31.