



Deposited via The University of Leeds.

White Rose Research Online URL for this paper:

<https://eprints.whiterose.ac.uk/id/eprint/83124/>

Version: Accepted Version

---

**Article:**

Hunter, IC, Musonda, E, Parry, R et al. (2014) Transversal directional filters for channel combining. IET Radar, Sonar and Navigation, 8 (9). pp. 1288-1294. ISSN: 1751-8784

<https://doi.org/10.1049/iet-rsn.2013.0330>

---

**Reuse**

Items deposited in White Rose Research Online are protected by copyright, with all rights reserved unless indicated otherwise. They may be downloaded and/or printed for private study, or other acts as permitted by national copyright laws. The publisher or other rights holders may allow further reproduction and re-use of the full text version. This is indicated by the licence information on the White Rose Research Online record for the item.

**Takedown**

If you consider content in White Rose Research Online to be in breach of UK law, please notify us by emailing [eprints@whiterose.ac.uk](mailto:eprints@whiterose.ac.uk) including the URL of the record and the reason for the withdrawal request.

# Transversal Directional Filters for Channel Combining

Ian Hunter, *Fellow*, IEEE, Evaristo Musonda, *Student Member*, IEEE, Richard Parry, Michael Guess, Philip Sleigh, Martin Gostling, Meng Meng

**Abstract**—A new concept for the design of power combiners based on matched directional filters is presented. The directional filters consist of individual balanced sections composed of hybrids and single resonators. Each of the sections corresponds to a pole of an all-pass function composed of the sum of  $S_{11}$  and  $S_{12}$  of the desired filter transfer function. A simple synthesis method is presented. The filter combiner has the advantage of ease of tunability because each pole is associated with a single resonator. Furthermore, no cross couplings are required to realize finite frequency transmission zeros. Experimental results for a prototype device are presented.

**Index Terms**— directional filters, combiner, power divider, general Chebyshev filter.

## I. INTRODUCTION

Recent requirement to share sites for mobile communication base stations require the use of duplexers or multiplexers so that two or more bands may be transmitted on a single antenna simultaneously allowing service providers in the same vicinity to share antennae. This paper demonstrates a novel approach for designing combiners based on Directional Filters (DF's) which can be used in Long Term Evolution (LTE) base stations.

The concept of directional filtering has been presented in the literature over the past decades. Common designs use striplines [1]-[3] and waveguide [4] technologies. A DF is a matched four-port device shown in Fig.1a with an input at port 1. Power emerges at port 3 with the frequency response of a band-pass filter and the remaining power emerges at port 2 with the complementary response of a band-reject filter. Port 4 is isolated. **In the design of DF, we use standard filter characteristics as illustrated in Fig 1b where  $S_{12}$  is the return loss of a general Chebyshev filter and  $S_{13}$  is its insertion loss with two transmission zeros.**

Because of the transmission characteristics of DF's, they may be used for signal combining or multiplexing. As opposed to conventional techniques of designing combiners, this technique does not involve the design of channel filters or junctions. Instead, a single bandpass filter characteristic is used such that the insertion and return loss of this bandpass filter provides the

The authors would like to thank Radio Design Ltd and Royal Academic of Engineering for the sponsorship of this work.

Ian Hunter is with the Institute of Microwaves and Photonics, School of Electronic and Electrical Engineering, University of Leeds, Leeds LS2 9JT, UK ([I.C.Hunter@leeds.ac.uk](mailto:I.C.Hunter@leeds.ac.uk))

Evaristo Musonda is with the Institute of Microwaves and Photonics, School of Electronic and Electrical Engineering, University of Leeds, Leeds LS2 9JT, UK ([e11em@leeds.ac.uk](mailto:e11em@leeds.ac.uk))

Richard Parry, Michael Guess Philip Sleish and Martin Gostling are with Radio Design Ltd, Shipley Wharf, Wharf Street, Shipley ,West Yorkshire,BD17 7DW, UK

Meng Meng is with the Institute of Microwaves and Photonics, School of Electronic and Electrical Engineering, University of Leeds, Leeds LS2 9JT, UK ([elmm@leeds.ac.uk](mailto:elmm@leeds.ac.uk))

forward transmission characteristics of each band. Because the two passbands are formed by the insertion and return loss of a single filter characteristic, the two channels of the combiner have no interaction even when the two bands are very close to each other.

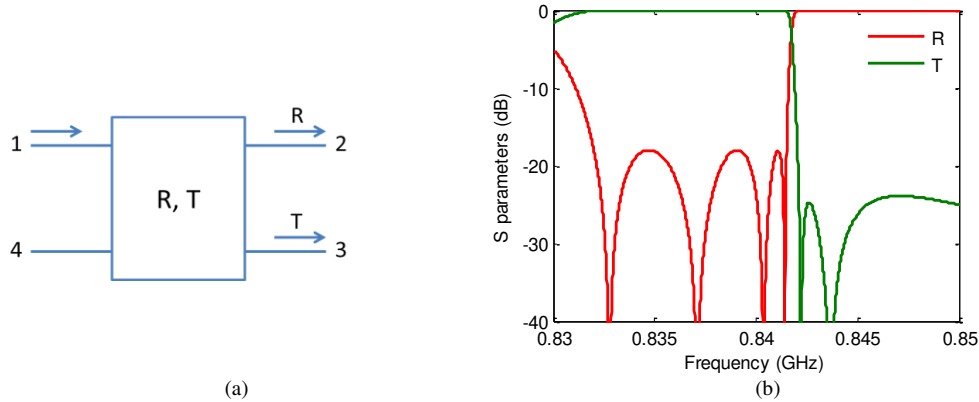

Fig. 1. A simplified diagram for a DF (a) and its response (b) that can be used for power combining.

The principles of operation of a DF used in this paper are an extension on the work presented in [6]. Section II presents the design theory for DFs. A synthesis method for cascaded DF's is presented in [7] and reviewed here. The design is based on a pole placement method where each single section of a DF is singly tuned to provide a pole of a bandpass filter. This may be realized by inserting two resonator networks between a pair of  $90^\circ$  hybrids. Cascading these matched four-port sections allows a multi-pole response equivalent to the characteristics of an  $N^{\text{th}}$  degree filter. As in a transversal array, each section of the network corresponds to a pole of the filter's admittance parameters [8]; each cascaded section in a DF realizes a pole of its S parameters.

As the design theory provides a DF in its lowpass prototype, Section III provides its the circuit realization. Bandpass characteristics are achieved by standard transformations. Various approximations are used to derive a simplified and realizable equivalent circuit. The final circuit contains resonators and some internal couplings that can be implemented by standard filter technologies.

Section IV presents two design examples. First, the design concepts are validated with a design of a cellular combiner with specifications used in uplink 800 MHz LTE bands. The design is based on the characteristics of a  $4^{\text{th}}$  order general Chebyshev filter and the required selectivity is achieved by two transmission zeros placed close to the passband. The cellular combiner was fabricated using coaxial resonators. The proposed solution achieves good isolation between the input ports, return loss and minimum in-band insertion loss. Dual or multi-bands responses can also be implemented with DF's. With the responses derived using the optimization presented in [9], the same synthesis method for DF's can be applied. The second example is given with two passbands at 1.635-1.645GHz and 1.735-1.745GHz. Each passband is realized by a  $2^{\text{nd}}$  response with one transmission zero in the upband. 30dB isolation is achieved within each band.

## II. DESIGN THEORY

### A. Single section DF's

The original design theory [6] was based on the DF configuration shown in Fig. 2. The DF consists of two identical filters and a pair of 3 dB hybrids. The scattering matrix of the filter network is given in (1). For this DF, the power incident at port 1 emerges at port 2 with the return loss of the filter network and at port 3 with the insertion loss. Port 1 is matched and port 4 is isolated. The response of the DF with R the power transferred to port 2 and T the power transferred to port 3 is thus given as in (2).

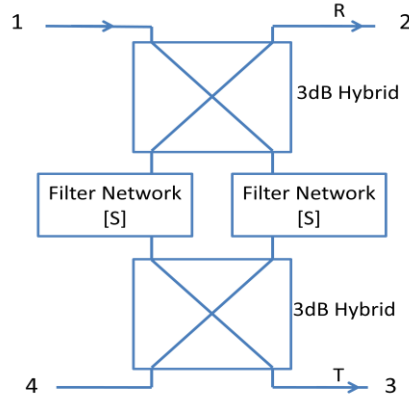

Fig. 2. Detailed diagram of DF with two identical filter networks inserted between a pair of 90° hybrids.

$$[S] = \begin{bmatrix} S_{11} & S_{12} \\ S_{21} & S_{22} \end{bmatrix} \quad (1)$$

$$R = jS_{11} \quad (2)$$

$$T = jS_{21}$$

In our design, the filter network is a single resonator and higher order characteristics are achieved by cascading these single sections.

### B. Cascaded directional filters

The single section of DF can be cascaded as shown in Fig. 3. The response of a single section is shown in (3). For a cascade of two sections, (3) is the input to the second section.  $P_I$  input at port 1 provides  $P_I R_I$  at port 2 and  $P_I T_I$  at port 3. Because of the symmetry of the network,  $Q_I$  input at port 4 provides  $Q_I R_I$  at port 3 and  $Q_I T_I$  at port 2. So the response of two sections is the combination of those outputs as in (4).

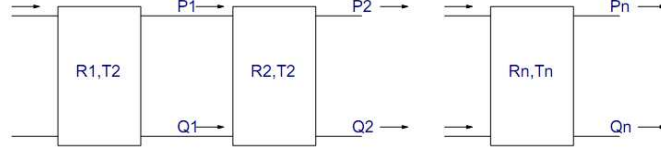

Fig.3. Cascading of n single section DF's.

$$P_1 = R_1 \quad (3)$$

$$Q_1 = T_1$$

$$P_2 = R_1 R_2 + T_1 T_2 = P_1 R_2 + Q_1 T_2 \quad (4)$$

$$Q_2 = R_1 T_2 + T_1 R_2 = P_1 T_2 + Q_1 R_2$$

With (3) being the initial values, a recurrence formula in (5) can be derived for the cascading of n sections. From the expression for  $P_n + Q_n$ , we can derive the equation in (6) which represents an all-pass response.

$$P_n = P_{n-1} R_n + Q_{n-1} T_n \quad (5)$$

$$Q_n = P_{n-1} T_n + Q_{n-1} R_n$$

$$P_n + Q_n = \prod_{i=1}^n (R_i + T_i) \quad (6)$$

### C. Decomposition of filter characteristics

The S parameters of a lossless filter network may be expressed as rational polynomials as in (7). **E is the common denominator of S parameters whose degree is the degree of filter network. F11 is the numerator of the return loss which contains all the reflection zeros. P is the numerator of insertion loss and contains all the transmission zeros.** The sum of these parameters is given in (8) which is also an all-pass response and n is the filter order,  $z_i$  represents a zero and  $p_i$  represents a pole.

$$S_{11} = \frac{F_{11}}{E}, \quad S_{21} = \frac{P}{E} \quad (7)$$

$$S_{11} + S_{21} = \frac{F_{11} + P}{E} = \frac{\prod_{i=1}^n (s - z_i)}{\prod_{i=1}^n (s - p_i)} \quad (8)$$

From power conservation, we can derive (9), which states that  $p_i$  is the same as either  $z_i$  or its conjugate.

$$E \cdot E^* = (F_{11} + P) \cdot (F_{11} + P)^* \quad (9)$$

By equating the two all-pass responses in (5) and (8), for a given filter characteristics,  $P_n + Q_n$  are known (10). By the decomposition of poles,  $R_i$  and  $T_i$  of each section can be derived according to (11) which states that  $R_i$  and  $T_i$  have the same pole

$p_i$  and the zeros of the numerator of  $R_i+T_i$  are  $z_i$ . As a result, each pole of a filter characteristic may be realized by a single DF section and a higher order response may be formed by cascading DF's. The next problem is to find the network realisation with reflection coefficient  $R_i$  and transmission coefficient  $T_i$ .

$$P_n + Q_n = \frac{F_{11} + P}{E} \quad (10)$$

$$R_i + T_i = \frac{s - z_i}{s - p_i} \quad (11)$$

### III. CIRCUIT REALIZATION OF A DF NETWORK

#### A. Realisation of Filter network

A simple resonator network as shown in Fig.4 is used to provide the characteristics of  $R_i$  and  $T_i$ . The network consists of a capacitance C and a frequency invariant reactance B which is included for complex poles. The transfer matrix of this network is given in (12a) and its S parameters can be derived as in (12b).

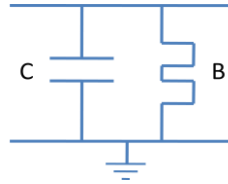

Fig. 4. Filter network to provide the required pole of a DF.

$$T = \begin{bmatrix} 1 & 0 \\ sC + jB & 1 \end{bmatrix} \quad (12a)$$

$$S_{11} = -\frac{s + jB/C}{s + jB/C + 2/C} \quad (12b)$$

$$S_{21} = \frac{2/C}{s + jB/C + 2/C}$$

According to the S parameters in (12b), we have a all pass response in (13a) whose magnitude should be equivalent to that in (11), as a result, a pole in (11) is shown in (13b). Then we obtain the values for the capacitance and frequency invariant reactance according to the values of poles as in (13). It should be noted that in the case when  $z_i$  is of the complex conjugate of  $p_i$ , a 180° phase shifter should be introduced after the  $i^{\text{th}}$  section.

$$S_{11} + S_{21} = -\frac{s + jB/C - 2/C}{s + jB/C + 2/C} \quad (13a)$$

$$p_i = jB/C + 2/C \quad (13b)$$

$$\begin{aligned}
 C_i &= -\frac{2}{\operatorname{Re}(p_i)} \\
 B_i &= \frac{2 \operatorname{Im}(p_i)}{\operatorname{Re}(p_i)}
 \end{aligned}
 \tag{13c}$$

### B. Node diagram

The complete admittances of a DF section are shown in Fig. 5 which is derived from Fig.2. Then number on the hybrid refers to the admittance of each  $90^\circ$  TL branch. The Y block refers to the filter network which is represented by its admittance matrix.

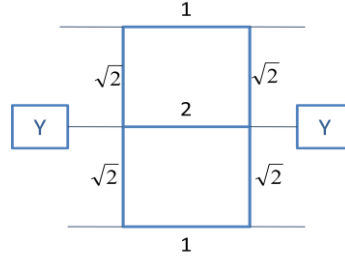

Fig. 5. Circuit diagram showing the admittances of a single section DF.

By replacing the  $90^\circ$  TL with invertors of different characteristic admittance, the network can be represented by a 4-port coupling matrix as illustrated by node diagram in Fig. 6a in which the empty dots represent non-resonating nodes. According to the node diagram in Fig.6, a coupling matrix that is usually used in the filter design can be found for a DF. The response of cascaded DFs can then be found by analysis of the response of a coupling matrix using the standard method given in [10]. In this way the response of DF networks are found by matrix analysis instead of circuit simulators. An alternative configuration for single section DF may be found as shown in Fig. 6b, while the dashed line represent negative couplings. This network is derived by scaling nodes in one of the hybrids and the two couplings in the center of the network cancel with each other. The response of this network remains the same except the port 3 and port 4 are exchanged.

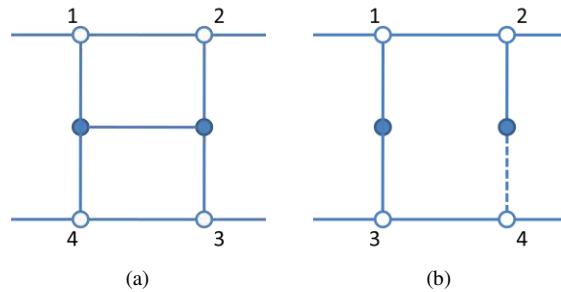

Fig. 6. Node diagram for single section DF (a) and its alternative (b). The empty node represents non-resonating nodes.

An  $N^{\text{th}}$  degree DF is derived by cascading  $N$  sections. Unlike a conventional filter, sections can be cascaded in any order. Fig. 7 shows the connection of two DF sections for the two configurations in Fig.6. The  $\varphi$  block represents the  $180^\circ$  phase shifter which should be added after the section when the corresponding  $z_i$  is the same as the conjugate of  $p_i$ .

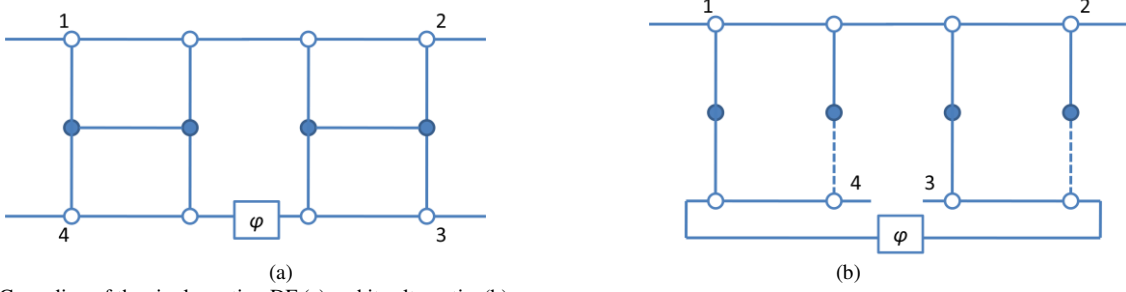

Fig. 7. Cascading of the single section DF (a) and its alternative(b).

### C. Circuit simplification

The final circuit for a section may be derived after some scaling and simplifications. Standard lowpass to band-pass transformations are applied. The branches for the  $90^\circ$  hybrid are replaced by an equivalent  $\pi$  network of inductances as shown in Fig. 8(a). Elements of the inductances of the  $\pi$  network are then merged with the resonators. The  $90^\circ$  TL with unit  $Z_0$  at the input and output is replaced by an equivalent TL as shown in Fig. 8(b).

TABLE I  
ELEMENT VALUES FOR THE DF SECTIONS

Roots of $F_{11}$	Roots of E	Roots of $F_{11}+P$	C	B
-0.8366i	-0.7005-1.2885i	0.7005-1.2885i	0.9636	3.6787
0.9805i	-0.9531+0.2651i	-0.9531+0.2651i	0.7021	3.6787
0.7632i	-0.3062+0.9603i	0.3062+0.9603i	2.1762	-6.2716
0.0751i	-0.0537+1.0451i	-0.0537+1.0451i	2.1762	-38.9048

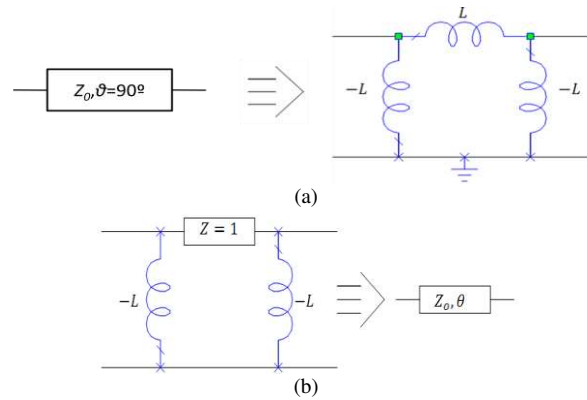

Fig. 8. Equivalent circuit for (a) a  $90^\circ$  TL by a  $\pi$  network of inductances and (b) a  $90^\circ$  TL with shunt inductances at the input and output by a TL with different characteristic impedance and phase length.

The final circuit for the single section DF is given in Fig.9.  $L'$  and  $C'$  can be realized by conventional resonators such as coaxial and dielectric resonators. The inductances  $L_v$  represents the input coupling to the resonators and  $L_m$  represents inter coupling between the resonators.

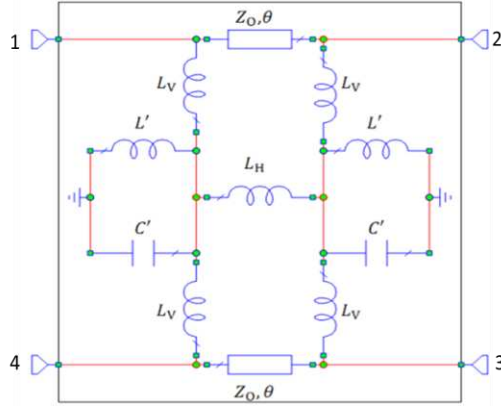

Fig. 9. Simplified circuit for a single section DF.

#### IV. DESIGN EXAMPLES

##### A. A 4<sup>th</sup> order DF

With cascaded sections, high performance combiners may be designed. A combiner with two passbands of 832-841.5 MHz and 842.5-852MHz is used as an example to illustrate the design theory. The required passband return loss is >18dB and the insertion loss is <1dB.

A 4<sup>th</sup> order general Chebyshev filter is used. Because the two bands are close to each other, the filter characteristic should have a steep transition and is realized by two transmission zeros close to the passband. The transmission zeros are at  $1.15j$  and  $1.45j$  in the lowpass domain. After synthesizing the general Chebyshev response using the method given in [11], we have the polynomials  $F_{11}$  and  $E$  of the lowpass prototype and  $R_i$  and  $T_i$  of each section are found according to (11). Values of the capacitors and frequency invariant reactances are calculated according to (13) and are listed in Table I. A lowpass to bandpass transformation is applied to each resonator and the network is combined with the equivalent circuit of the 90° hybrid. Then the four DF sections are cascaded. The circuit model is simulated in ADS and the result is shown as the solid lines in Fig. 12 and it is the same as the synthesized Chebyshev response.

An EM model for the circuit in Fig. 9 using coaxial resonators is shown in Fig.10(a). The main branch of the hybrid is realized by a 50Ω line. The input couplings are realized by non-resonating stubs and the inter resonator coupling is realized by a window. As a lossless design, we used PEC for conductors. For this 4<sup>th</sup> order example, an EM model was built for each DF section in HFSS. As each DF section has a different resonant frequency and couplings, the EM model was tuned until the response as illustrated in Fig. 10(b) for the first section is consistent with that of the circuit model. The four-port S parameters of each DF section were then put in ADS and connected by TLs. The result of this combined EM and circuit simulation is given in Fig.11 as the dashed line responses.

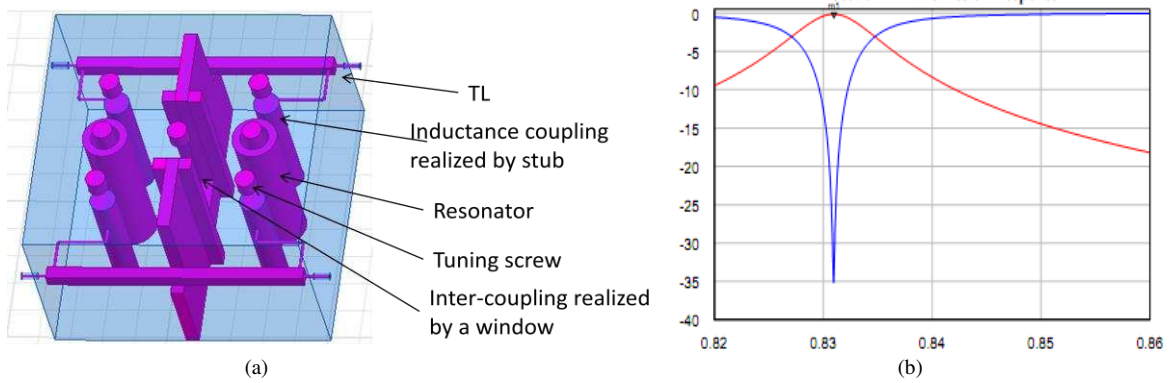

Fig. 10. EM model of a single section DF in HFSS (a) and its typical response (b).

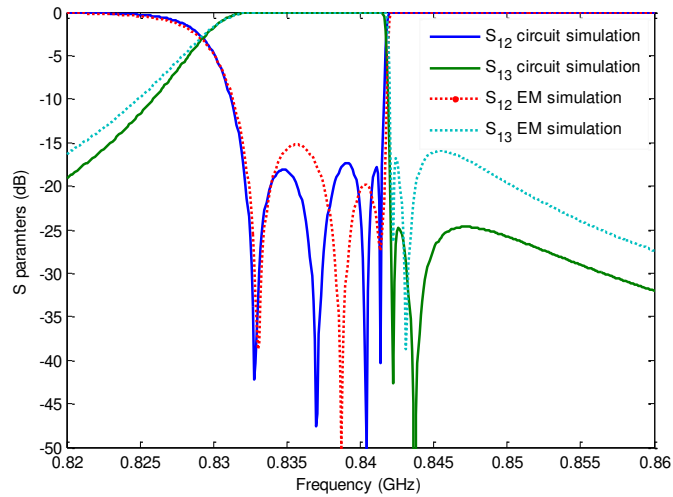

Fig. 11. Simulation result for the combiner (Solid line for the circuit simulation and dashed line for the combined EM/circuit simulation)

The EM model of the whole structure is shown in Fig.12. Because each DF section controls one pole of the filter characteristic, they may be tuned independently. No cross couplings are required when realizing transmission zeros and thus through tuning, different kinds of responses may be achieved by the same structure.

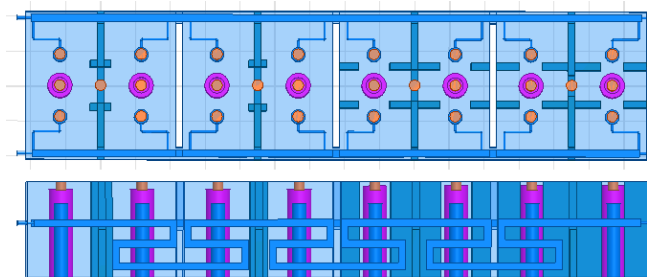

Fig. 12. EM model for the combiner (top view and side view).

Different  $Q$ s may be assigned to each section (800, 650, 4,000, 20,000), obtaining similar selectivity to a lossless filter and requiring a minimum number of high  $Q$  resonators. The insertion loss in the passband is compared between a lossless circuit and

a lossy circuit with non-uniform  $Q$  in Fig.13.

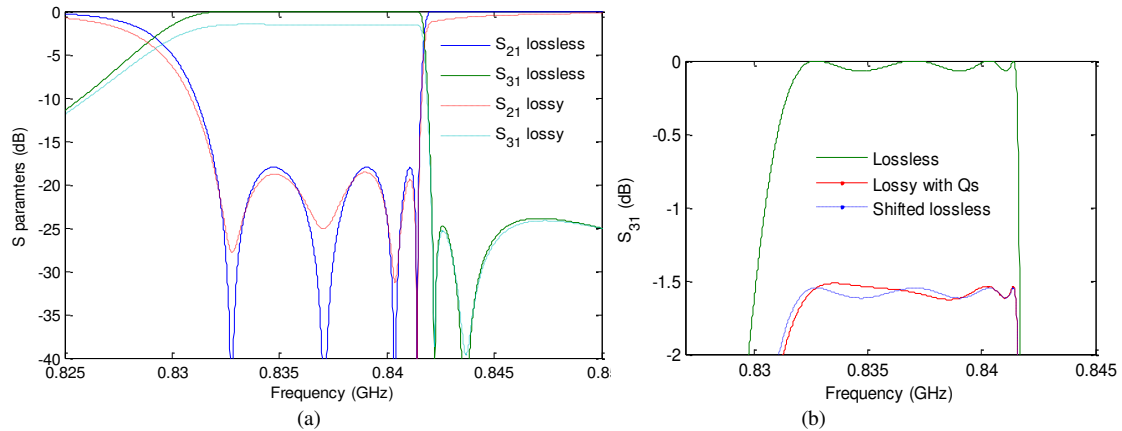

Fig. 13. S parameters of the lossy combiner compared with the lossless one.

### B. DF with Dual Response

Dual-band or multi-band characteristics may be achieved with the same physical configuration by choosing the appropriate transfer function. With the dual or multi-band  $F_{11}$ ,  $E$  and  $P$  polynomials derived by optimization method given in [9], the synthesis of DF sections remains the same.

The example here is a 4<sup>th</sup> order dual-band combiner with two passband at 1.638-1.648GHz and 1.735-1.745GHz. For each band, a transmission zero is included in the upband to achieve a rejection of 10dB. The return loss level is 15dB. The element values of the circuit model of this DF are listed in Table II and the simulation results are shown in Fig. 16 as the dashed lines. From the S parameters, we can see that each passband corresponds to a 2<sup>nd</sup> response.

TABLE II  
ELEMENT VALUES FOR THE DUAL-BAND DF SECTIONS

Roots of $F_{11}$	Roots of $E$	Roots of $F_{11}+P$	$C$	$B$
0.9848i	-0.0357+1.0277i	0.0357+1.0277i	56.0884	-57.6417
0.8641i	-0.2109+0.8373i	-0.2109+0.8373i	9.4847	-7.9411
-0.9725i	-0.2167-1.0415i	0.2167-1.0415i	9.2281	9.6112
-0.8308i	-0.0415-0.7778i	-0.0415-0.7778i	48.1663	37.4649

Measured transmissions are shown in Fig. 14(a) as the solid line. 30dB isolation is achieved within each band as shown in Fig. 14(b). For the two resonators in each band,  $Q_{us}$  are 4400 and 3000 respectively. The 1dB channel bandwidths are 10MHz. A photo of the device is given in Fig. 15.

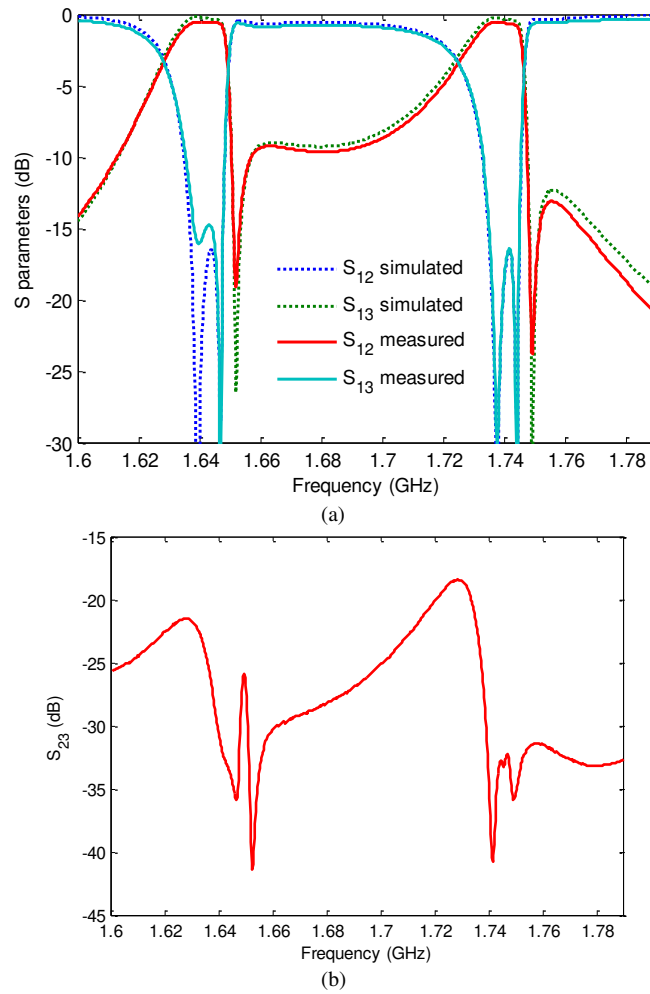

Fig. 14. Simulated and measured (a) transmissions and (b) isolation of the dual-band combiner.

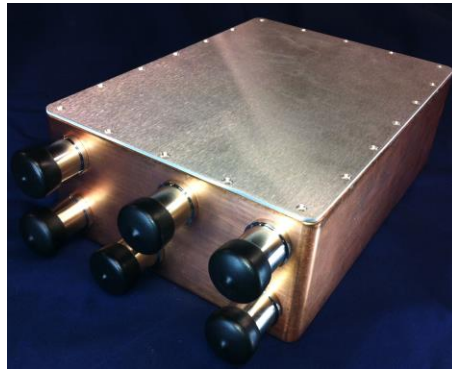

Fig. 15. Photograph of the device made.

## V. CONCLUSION

A new concept for designing channel combiners based on directional filters has been presented. Multi-section DF's are synthesized as a cascade of first-order all-pass networks. With cascaded DF's, high performance combiners may be designed. Because the two pass-bands are formed by the insertion and return loss of a single filter characteristic, the two channels of the

combiner have little interaction even when the two bands are very close to each other. The combiner is simple to tune as each section is independent of the others and the structure requires no cross couplings. As in the case of transversal filters, non-uniform Q resonators may be used to great effect.

#### REFERENCES

- [1] Matthaei G. L., Young L., and Jones E. M. T., *Microwave Filters, Impedance Matching Networks and Coupling Structures*, Norwood, MA: Artech House, 1964, pp. 165–173, 243–252.
- [2] Wanselow, R.D. and Tuttle, L.P. Jr., “Practical design of strip transmission line half-wavelength resonator directional filters”, *Trans. IRE*, Jan. 1959, vol. MTT-7, pp. 168-173
- [3] Coale, F.S., “A Travelling-Wave Directional Filter”, *Trans. IRE*, Oct. 1956, vol. MTT-4, pp. 256-260
- [4] Cohn, S.B.; Coale, F.S., "Directional Channel-Separation Filters," *Proceedings of the IRE* , vol.44, no.8, pp.1018,1024, Aug. 1956
- [5] Wing, O., “Cascade Directional Filter”, *Microwave Theory and Techniques, IRE Transactions*, 1959, vol. 7, no. 2, pp. 197-201
- [6] Rhodes, J. D. and Mobbs C.I., “Explicit Design of remote-tuned combiner for GSM and WCDMA signals”, *International Journal of Circuit Theory and Applications*, September – December 2007, vol. 35, no.5-6, pp. 547-564
- [7] I. C. Hunter, E. Musonda, R. Parry, M. Guess, M. Meng, “Transversal Directional Filters for Channel Combining”, *Microwave Symposium Digest, 2013 IEEE MTT-S International*, June 2013.
- [8] R. J. Cameron, “Advanced Coupling Matrix Synthesis Techniques for Microwave Filters,” *IEEE Trans. Microw. Theory Tech.*, vol.51 , no.1 , pp.1-10, Jan. 2003.
- [9] Lunot, V.; Seyfert, F.; Bila, S.; Nasser, A., "Certified Computation of Optimal Multiband Filtering Functions," *Microwave Theory and Techniques, IEEE Transactions on* , vol.56, no.1, pp.105,112, Jan. 2008
- [10] Garcia-Lamperez, A.; Salazar-Palma, M.; Sarkar, T.K., "Analytical synthesis of microwave multiport networks," *Microwave Symposium Digest, 2004 IEEE MTT-S International*, vol.2, no., pp.455,458 Vol.2, 6-11 June 2004