



Deposited via The University of York.

White Rose Research Online URL for this paper:

<https://eprints.whiterose.ac.uk/id/eprint/81433/>

Version: Published Version

---

**Article:**

Duffy, A.P., Dawson, J.F., Flintoft, I.D. et al. (2014) Electromagnetic Monitoring of Semiconductor Ageing. *Procedia CIRP*. 98 - 102. ISSN: 2212-8271

<https://doi.org/10.1016/j.procir.2014.07.130>

---

**Reuse**

Items deposited in White Rose Research Online are protected by copyright, with all rights reserved unless indicated otherwise. They may be downloaded and/or printed for private study, or other acts as permitted by national copyright laws. The publisher or other rights holders may allow further reproduction and re-use of the full text version. This is indicated by the licence information on the White Rose Research Online record for the item.

**Takedown**

If you consider content in White Rose Research Online to be in breach of UK law, please notify us by emailing [eprints@whiterose.ac.uk](mailto:eprints@whiterose.ac.uk) including the URL of the record and the reason for the withdrawal request.

3rd International Conference on Through-life Engineering Services

## Electromagnetic Monitoring of Semiconductor Ageing

A.P. Duffy<sup>a\*</sup>, J.F. Dawson<sup>b</sup>, I.D. Flintoft<sup>b</sup> and A.C. Marvin<sup>b</sup>

<sup>a</sup>De Montfort University, The Gateway, Leicester LE1 9BH, UK

<sup>b</sup>The University of York, Heslington, York YO10 5DD, UK

\* Corresponding author. Tel.: +44-116-257-7056; E-mail address: [apd@dmu.ac.uk](mailto:apd@dmu.ac.uk)

### Abstract

This paper reports on the outcomes of the project “Electromagnetic Monitoring of Semiconductor Ageing” funded through the *EPSRC Centre for Innovative Manufacturing in Through-life Engineering Services*. The basis of the feasibility study reported in this paper is that all active devices exhibit non-linear behaviour and the behaviour of those devices will change as they age. As a result, the radiation or re-radiation of intermodulation products will change as the device ages. The goal of the project is to verify that this change in non-linear behaviour could be identified in a way that does not require modification of existing circuitry, thus allowing through-life and non-destructive monitoring of devices for signs of early deterioration. Results obtained from this work have been very encouraging and have set the scene for further development of the techniques to include degradation fingerprinting and system health monitoring.

© 2014 Published by Elsevier B.V. This is an open access article under the CC BY-NC-ND license (<http://creativecommons.org/licenses/by-nc-nd/3.0/>).

Peer-review under responsibility of the Programme Chair of the 3rd International Through-life Engineering Conference

*Keywords:* Intermodulation; Electromagnetic Compatibility; Radiation, Failure prediction; Semiconductor Ageing.

### 1. Introduction

The semiconductor junction is probably the single most influential development in human development of the post-industrial age, possibly surpassing the manufacture of oil-based consumable products in its importance to the public. There are very few technologies that do not rely on transistors or microprocessors, either directly or indirectly. As a result, the semiconductor junction is also at the heart of virtually all critical systems. Either for pure economic benefits or for those of human or functional safety, the ability to provide an early warning of impending device / system failure has many advantages. These include being able to plan maintenance schedules as a result of need rather than simply look to repair failed systems or use a time-scheduled maintenance scheme. Such early warning would allow timely decommissioning / re-commissioning with minimum disruption to the other functions around the system in question. However, to be able to do this, the measurement of ageing needs to be achievable

in some way that can allow ongoing monitoring but without the need for the measurement systems to be electrically part of the system being tested. This requirement is to avoid costly redesign of the systems being monitored.

This paper reports on a first step to achieve this goal. The project *Electromagnetic Monitoring of Semiconductor Ageing*, funded through the *EPSRC Centre for Innovative Manufacturing in Through-life Engineering Services (Project C15)* has sought to verify that the passive and active monitoring of electromagnetic emissions has validity as a candidate technique in undertaking this assessment.

The aims of the project were to:

1. ascertain whether age dependent signatures can be obtained by non-contact electromagnetic methods for analogue, digital and power circuits;
2. compare with a passive approach with our active illumination approach to establish the likely performance of each method in the detection of ageing effects;

- provide a first analysis of the complexity in time and frequency of the resulting signatures and identify mechanisms to quantify the ageing and identify precursors to failure.

This paper discusses the methods developed for the project, the results and the conclusions that can be derived from those results. It first provides a brief review of semiconductor ageing.

## 2. Semiconductor Ageing

Ageing is an expected and anticipated result of a device being used. It is reasonable to expect that after a period of usage, a device will not perform as well as it did on manufacture. It is also reasonable to assume that many of the mechanisms associated with ageing will be made worse if the device is more highly stressed through electrical, thermal or mechanical means. In practice, electronics is seeing reductions in the dimensions of devices and increases in the numbers of devices being integrated in a single system. Thus, ageing, and the monitoring of resulting degradation of performance is an important task in designing for reliability and designing for reparability.

There are several mechanisms for performance degradation and ultimate failure of semiconductor systems. Some of the key mechanisms are:

- Hot carrier injection where charge carriers travel outside the active channel.
- Bias Temperature Instability caused by a build-up of charge in the insulating layer.
- Oxide breakdown where breakdown occurs because of charge traps in the oxide layer.
- Electromigration, where atoms move under high electrical stress.
- Thermomigration, where atoms move under high thermal stress.

A good bibliography of these mechanisms is provided in [1]. The process of monitoring proposed in [1] is at the silicon level with the introduction of test structures to monitor for variations in parameters such as resistance, voltage, etc. “Canary”-type structures are mentioned: these are structures that notify the monitoring system when a preset level has been exceeded.

Many of these phenomena have been known about and researched for many years, with acceleration factors being used to determine the anticipated life from measurements taken under higher stress conditions than would be experienced under normal usage. In fact, in [2], Black proposed a link between the temperature at which the device is operated and the mean time to failure (MTTF). Hence, it is accepted that accelerated testing, under levels of increased thermal or electrical stress (for example) provide an acceptable proxy for running tests for unacceptably long periods.

One effect of the ageing of semiconductors may be a change in their non-linearity performance with a resulting change in their intermodulation performance. This is a phenomenon discussed later in this paper. More generally, the

overall frequency response of semiconductors could change as the ageing mechanisms, previously discussed, alter their switching performance, which will then result in a change in the frequency response. Hence, one method to determine changes in the performance of a device is to measure the frequency ‘signature’, age the device and then re-measure. Any changes in this signature can then be attributed to ageing phenomena, assuming all other parameters have not changed. This approach was used in [3] where several power supplies had their radiation performance measured according to the methods detailed in a predecessor to [4]. The results were compelling, in that after only a few cycles, each of a few hours, of ageing at an elevated temperature of only 80°C appreciable differences were recorded over a low frequency range which extended up to only a few 10s of MHz.

## 3. Test system design

Three systems were chosen for testing in this study. These were a switched mode power supply unit, a PIC microcontroller circuit and an audio amplifier. These were chosen to provide a bridge with previous published literature and to be broadly representative of systems in widespread use, viz. a digital system, an analogue system and a power supply.

The circuit boards were designed and fabricated specifically for the tests and each included identical radio frequency pickups designed on the circuit boards. The RF pick-ups were 50  $\Omega$  printed couplers. These pickups were not part of the circuits themselves but were co-located on the boards to ensure absolute repeatability of the tests, resulting in the only variable being the performance of the particular semiconductor-based device being aged. Such an approach avoids any possible source of error due to minor placement difference between tests, as might occur if implementing the approach described in [4]. Figure 1 illustrates how this is incorporated into the circuit boards.

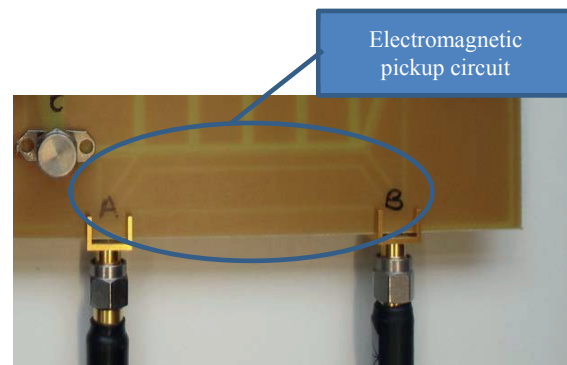

**Fig. 1** Non-contact electromagnetic pickup.

Other design features that were included in order to remove external influences were that the boards were powered by rechargeable cells, and not external power supplies, as well as the active devices that were being tested were plugged into the circuit boards to avoid having to temperature cycle the boards as well.

The test set-up can be seen schematically in Figure 2. The spectrum analyzer as indicated. Where no re-radiation is

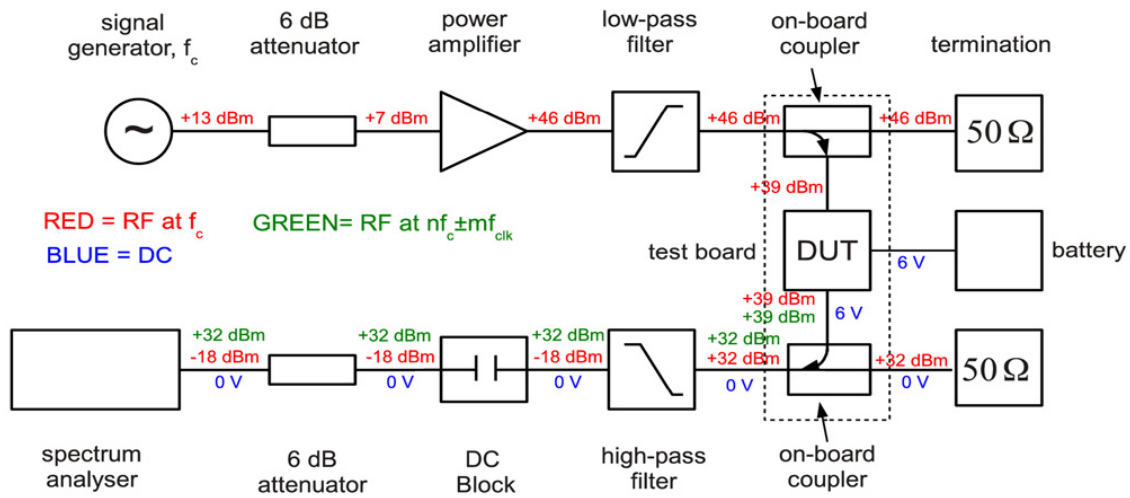

DUT is the device under test. The signal generator could be used to inject CW signals into the circuit to enable re-radiation/ intermodulation effects to be measured by the

required, i.e. simple device radiation, the signal generator connection is replaced by a 50Ω termination.

**Fig. 2** Schematic showing the test equipment connection to the device under test

The thermal cycling used for the devices was more aggressive than the approach used in [3]. One third of the devices were not aged, two thirds were aged at an ambient of 140°C for one week and half of those (one third of the total batch) were aged for an additional one week at 140°C. All devices were measured at each stage, which allows a measure of the repeatability of the results to be obtained.

**4. Test results**

*4.1. PIC Microcontroller*

The PIC was chosen because it represents a programmable digitally based system. The PIC 18F14K22 was chosen because it is one of the only PIC devices to be capable of being socket mounted. The PIC itself was programmed to simply toggle the outputs.

The level of repeatability that was obtained can be seen in Fig. 3 which shows the same emissions spectrum measurements, centred on ~27 MHz, and taken approximately two months apart. The graph shows both the peak values and the average values. It is clear that a high level of repeatability can be expected from the tests.

Figure 4 shows the effects on the spectrum following a single aging cycle. A similar proportional change was noted at other frequencies, however, the 98.7 MHz harmonic has been displayed for convenience. The shift in the harmonic is clear.

Figure 5 shows the effects on the spectrum of the same device after a further cycle of accelerated ageing. The further

shift in the harmonic can be clearly seen by comparison with Figure 4.

The re-emissions spectrum shows small changes, as indicated in Figure 6. While not a conclusion, an indication from these results is that the emissions spectrum could provide a more robust fingerprint which is more sensitive to ageing than the re-emissions spectrum.

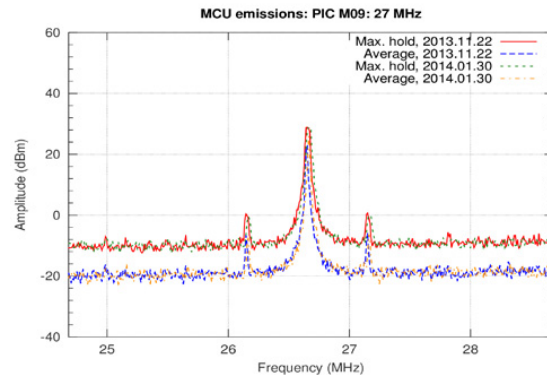

**Fig. 3** Repeatability spectrum for PIC measurements, showing amplitude in dBm versus frequency. Note: the upper lines are Max-Hold and Average values of amplitude taken in November, the lower lines are the same measurements repeated two months later.

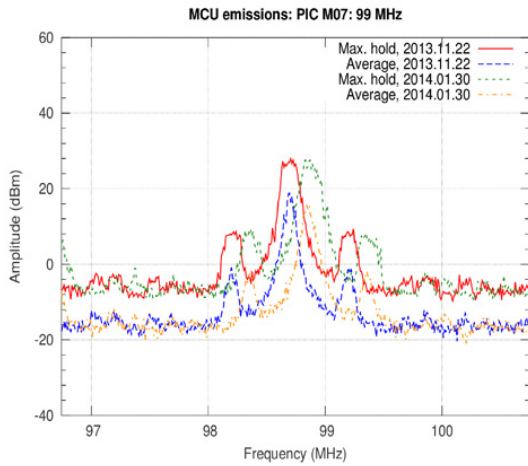

**Fig. 4** PIC spectrum after one cycle of accelerated ageing. Note: the upper lines are Max-Hold, the lower are average

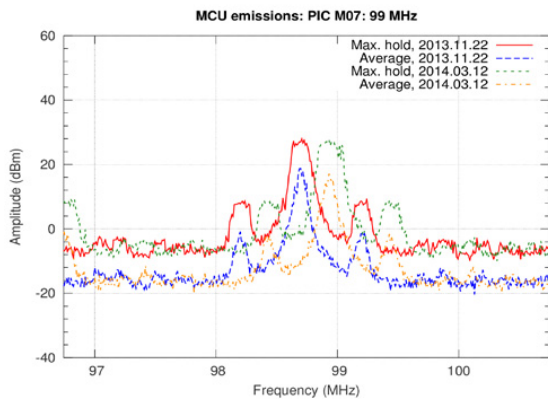

**Fig. 5** PIC spectrum after two cycles of accelerated ageing. Note: the upper lines are Max-Hold, the lower lines are average and a clear frequency shift is visible.

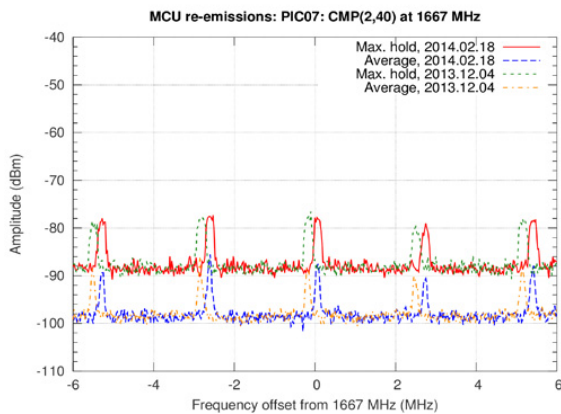

**Fig. 6** PIC re-emissions spectrum affected by two cycles of accelerated ageing. Note the frequency shift in both peak and average values

4.2. Switch mode power supply MOSFET characteristics

The switched mode power supply was based on switching a MOSFET device. At the time of writing, the re-emissions tests had not been completed but the emissions tests showed noticeable, if not gross, shifts in spectra following the ageing regimen. Figure 7 shows the comparative spectrum for one typical device. While relatively subtle, compared with the PIC response, ageing induced shifts in features are most clearly discernable in the range 100 MHz – 130 MHz, approximately.

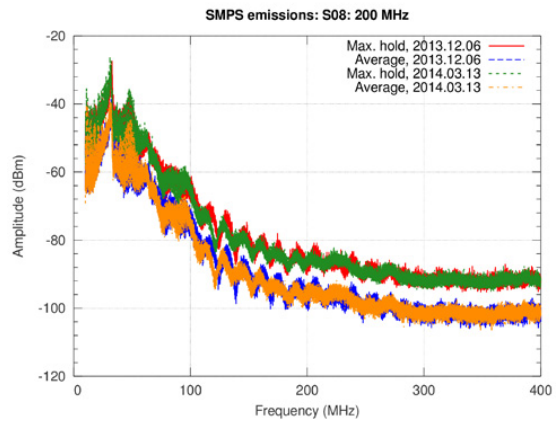

**Fig. 7** MOSFET Characteristic emissions spectrum, repeated after ~3 Months. Note: the upper lines are Max-Hold, the lower lines are average.

It is clear from Figure 7 that there are two superposed curves for each set of measurements: the cyclical structure of period approximately 16 MHz and a much more rapidly varying component. Hence, it is interesting to also look more closely at the measurements over a limited frequency range. These results also show a shift in frequency response.

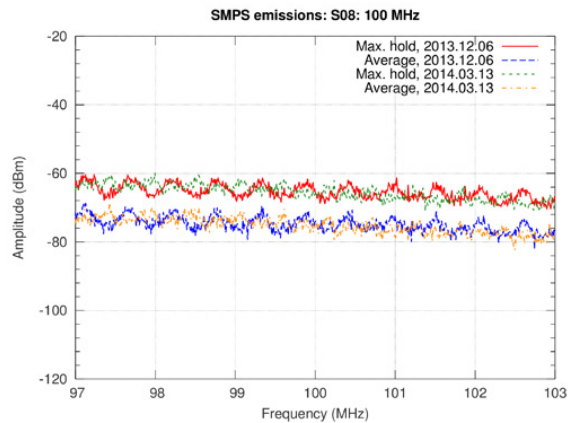

**Fig. 8** MOSFET Characteristic emissions spectrum, repeated after ~3 Months. Note: the upper lines are Max-Hold, the lower lines are average.

Again, whilst not capable of having full conclusions drawn from them, these figures are indicative of changes that could, possibly be monitored.

### 4.3. Audio amplifier BJT characteristics

The audio amplifier represents the analogue element of the three systems being analyzed for this project.

Figure 9 shows the comparison of the pre-aged and aged characteristics for one of the BJT devices centred on 1MHz. There is relatively little shift in the frequency response but there is an indication that something is happening. This is confirmed when the response at 5 MHz is considered (which is shown in Figure 10).

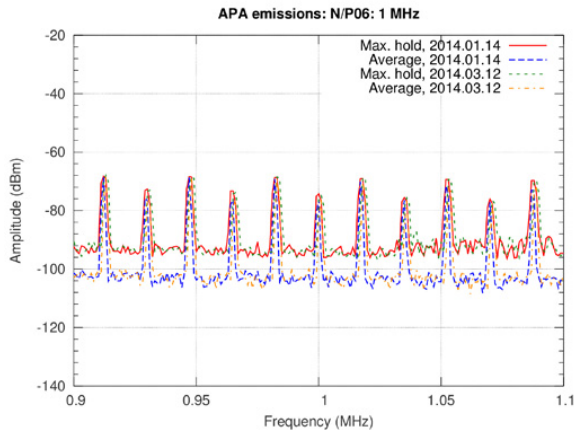

**Fig. 9** BJT Characteristic emissions spectrum (Max-Hold and average) centred on 1 MHz

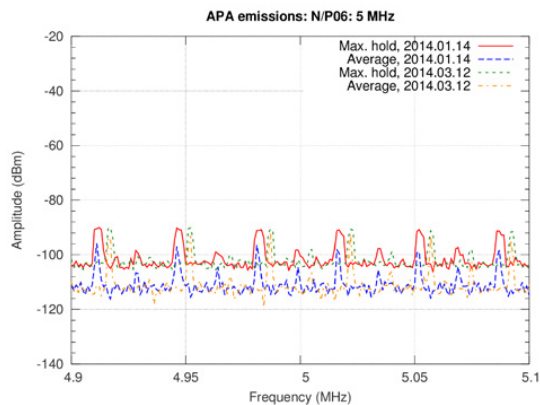

**Fig. 10** BJT Characteristic emissions spectrum (Max-Hold and average) centred on 5 MHz

These figures, as for the other devices tested, are typical of the BJTs tested.

## 5. Conclusion

Systems based on semiconductors have permeated virtually every walk of modern life. They continue to get smaller, with Moore's law continuing to hold despite the several technology revolutions required to enable this. Processor systems continue to require greater numbers of semiconductor devices to perform their functions. As a result, 'health monitoring' of such systems could add utility to the assessment of those systems' performances. This project has set out to assess

whether monitoring the electromagnetic emissions from a range of typical systems could have validity as an approach to be further developed to provide through-life assessment of the deterioration of electronic systems. The different technologies tested were based on Field Effect Transistors and Bipolar Junction Transistors. The systems being considered were an audio amplifier based on BJTs as a representative analogue system, a switched mode power supply based a FET as a representative digital system and a simple PIC microcontroller as a representative computer system.

Proportions of the devices were aged for one or two weeks at an elevated temperature to provide the necessary accelerated ageing function.

The results for all device families tested showed some change in performance characteristics as the devices underwent accelerated ageing.

The PIC showed the most variation for emissions measurements over the test period. This may be accepted because it is the most complex of the three 'devices' being considered and the cumulative probability of change of the individual semiconductor devices within the PIC are more likely to result in a modified performance than for a single device on its own. Having said this, some changes were observed with the FET and BJT as well.

Those changes were predominant when the radiation characteristics of the systems under normal operation were measured. Those initial radiation characteristics provided a baseline performance against which the aged characteristics could be compared.

The re-radiation characteristics were less clear-cut. Those re-radiation characteristics did show some indication of change in some samples but a more thorough study of the methods of assessing the intermodulation products will be required in any full study.

The end purpose of this project was to decide if a full project would be feasible. The results obtained show that there are characteristics of the radiation spectra that indicate ageing can be observed. The re-radiation approach may need to be re-thought out, but some changes observed indicate that this could also be a fruitful line of enquiry.

Emissions from semiconductor devices, measured from closely coupled RF pick-ups have given encouraging indications of the possibilities of non-contact system monitoring which can utilize convenient receivers and do not rely on balanced dipoles. Future work will investigate these emissions more fully.

## References

- [1] Manhaeve, H.; Mikkola, E.; "Semiconductor failure modes and mitigation for critical systems – embedded tutorial"; 18<sup>th</sup> IEEE European Test Conference (ETS); 27-30 May 2013; Avignon, France; pp 1 – 3.
- [2] Black, J.R.; "Electromigration – a brief survey and some results"; IEEE Transactions on Electron Devices, Vol 16, no 4, 1969, pp338 – 347
- [3] Montanari, I.; Tacchini, A. & Maini, M., (2008). Impact of thermal stress on the characteristics of conducted emissions. Electromagnetic Compatibility, 2008. EMC 2008. IEEE International Symposium on, 1-4
- [4] EN55022; "Information technology equipment – radio disturbance characteristics – limits and methods of measurement", December 2010.