



UNIVERSITY OF LEEDS

This is a repository copy of *Energy-Efficient Future High-Definition TV*.

White Rose Research Online URL for this paper:

<http://eprints.whiterose.ac.uk/81234/>

Version: Accepted Version

Article:

Osman, NI, Elgorashi, T, Krug, L et al. (1 more author) (2014) Energy-Efficient Future High-Definition TV. *Journal of Lightwave Technology*, 32 (13). pp. 2364-2381. ISSN 0733-8724

<https://doi.org/10.1109/JLT.2014.2324634>

Reuse

Items deposited in White Rose Research Online are protected by copyright, with all rights reserved unless indicated otherwise. They may be downloaded and/or printed for private study, or other acts as permitted by national copyright laws. The publisher or other rights holders may allow further reproduction and re-use of the full text version. This is indicated by the licence information on the White Rose Research Online record for the item.

Takedown

If you consider content in White Rose Research Online to be in breach of UK law, please notify us by emailing eprints@whiterose.ac.uk including the URL of the record and the reason for the withdrawal request.



eprints@whiterose.ac.uk
<https://eprints.whiterose.ac.uk/>

Energy-Efficient Future High-Definition TV

Niemah I. Osman, Taisir El-Gorashi, Louise Krug and Jaafar M. H. Elmirghani

Abstract—The rapidly growing IPTV market has resulted in increased traffic volumes raising concerns over Internet energy consumption. In this paper, we explore the dynamics of TV viewing behavior and program popularity in order to devise a strategy to minimize energy usage. We evaluate the impact of our strategy by calculating the power consumption of IPTV delivered over an IP-over-WDM network, considering both standard definition and high definition TV. Caches are used to reduce total energy consumption by storing the most popular programs at nodes closer to the end user. We then use our knowledge of viewing behaviors to generate a time-driven content replacement strategy to maximize cache hit ratios and minimize energy use. We develop a Mixed Integer Linear Programming (MILP) model to evaluate the power consumption of the network while performing time-driven content replacements on caches and validate the results by simulation. Finally, we extend our model to perform content replacements on caches with sleep-mode capabilities which can save power by reducing their size. Our results show that time-based content replacements with such variable caches increase cache hit ratios and so reduces the total power consumption by up to 86% compared to no caching. Our findings also show that more power savings are achieved for high definition TV compared to standard definition TV, so this strategy will be beneficial in the long term.

Index Terms—Core network energy efficiency, HDTV, Cache content replacement, IP over WDM, TV program popularity

I. INTRODUCTION

IPTV (Internet Protocol Television) is gaining popularity with telecom service providers competing to offer revenue-generating triple play services (i.e. voice, video and data). IPTV offerings can include broadcast TV, Video-on-Demand (VoD) and rich media content over IP. Forecasts indicate that global IPTV subscribers will grow from 53 million to 105 million between 2011 and 2015 with an expected revenue of \$45 billion in 2015 [1]. The increase in bandwidth required to support increasing numbers of users and increasing amounts of video has led to concerns about the energy consumed by the

Internet infrastructure. Specifically, the energy efficiency improvements achieved by technology enhancements do not compensate for the annual growth in Internet traffic [2]. Consequently, there is a need to identify energy-efficient solutions for the Internet which constrain energy use whilst maintaining Quality of Experience (QoE).

Data centres which manage and provide the content are a critical part of the network and consume significant energy - up to 70% of transmission energy. [3]. Caching the most popular content towards the edge of the network is an effective technique to reduce network traffic, latency and congestion and can reduce total energy consumption when the additional energy associated with the data caches is offset by reduced energy use associated with network transmission.

In our previous work in [4] and [5] we proposed a Mixed Integer Linear Programming (MILP) model to minimize the energy consumption of IPTV services in an IP-over-WDM (Wavelength Division Multiplexing) network by optimizing the size of caches deployed at network nodes. We also considered caches with sleep-mode capabilities (variable caches) such that caches can be partially powered down when the traffic is low. Our findings revealed that variable caches are needed to optimally minimize the power consumption. The work also showed that a fixed size cache can still reduce the power consumption of the network, with only a small power penalty due to the fixed size. We have also shown that the optimum cache size follows the trend of the traffic with more energy savings achieved when the traffic is high, supporting network scalability and future growth in Internet video traffic. However, this work did not consider any need for content replacement on the cache.

Content replacement schemes are used to manage content on the cache and respond to changes in data popularity. The Least Frequently Used (LFU) and Least Recently Used (LRU) algorithms have long been employed for cache management. Many content replacement algorithms derived from LFU and LRU have been proposed in the literature [6][10]. Maintaining a high cache hit ratio may improve energy efficiency. The prior work in content replacements considers two main types of caching algorithms:

- **Reactive:** a priori knowledge of requests is not available. The work in [6]-[10] describes reactive caching algorithms that are invoked when the cache is full. A request for data not in the cache results in an item being evicted from the cache. The aim of this type of caching algorithm is to decide which item to evict from the cache.
- **Proactive:** where full or partial prior knowledge of requests can allow a caching algorithm to update cache contents ahead of time [8].

In this paper, the full list of TV programs represents the list of all possible requests. We examine TV viewing trends and so propose and evaluate a new proactive method for cache

Manuscript received December 16, 2013. This work was supported in part by the Engineering and Physical Sciences Research Council (EPSRC), INTERNET (EP/H040536/1) and STAR (EP/K016873/1), King Abdulaziz University Deanship of Scientific Research (DSR), Gr/9/33, and the Islamic Development Bank (IDB).

N. I. Osman is with the School of Electronic and Electrical Engineering, University of Leeds, LS2 9JT, Leeds, United Kingdom, (e-mail: elnio@leeds.ac.uk).

T. El-Gorashi is with the School of Electronic and Electrical Engineering, University of Leeds, LS2 9JT, Leeds, United Kingdom, (e-mail: t.e.h.elgorashi@leeds.ac.uk).

L. Krug is with BT, Adastral Park, IP5 3RE, Ipswich, United Kingdom, (e-mail: louise.krug@bt.com).

J. M. H. Elmirghani is with the School of Electronic and Electrical Engineering, University of Leeds, LS2 9JT, Leeds, United Kingdom and with the Department of Electrical and Computer Engineering, King Abdulaziz University, Jeddah, Kingdom of Saudi Arabia, (e-mail: j.m.h.elmirghani@leeds.ac.uk).

management that uses the fact that TV viewing patterns are predictable. We propose updating the contents of caches a number of times a day to maintain the most popular content in caches. Updating cache contents by predicting which programs will be requested in the next time slot increases the cache hit ratios, which reduces the traffic traversing the network, reducing in turn the power consumption. It also allows us to minimize the cache size, again reducing power consumption. We consider standard definition TV (SDTV) as the most common video delivery technology for today's TV channels and high definition TV (HDTV) as the emerging technology rapidly replacing SDTV.

To the best of our knowledge, no prior work has been done in IPTV considering content replacements based on time of day for energy efficiency. We evaluate our proposal by developing a MILP model to minimize the overall power consumption by optimizing the number of times the cache content is replaced. We extend our model to perform content replacements on variable caches. When performing content replacements with variable caches the savings in the total power consumption are up to 86% compared to no caching. We conclude our study by investigating the influence of the presence of regular traffic in the network on the power savings. We consider a number of different traffic mixtures and evaluate average and maximum savings in power consumption under each scenario. Due to the linear property of our MILP models, service providers catering for video and non-video services will be able to estimate power savings based on the proportion of video in the traffic.

Our main contributions in this paper are: (i) compiling data that shows the dynamics of TV viewing (ii) evaluating the influence of time-based content replacements on cache hit ratios (iii) identifying the optimum number of daily cache content replacements that minimizes the power consumption of content delivery and caching considering TV video and regular traffic.

The remainder of the paper is organized as follows. Section II describes how IPTV is delivered over an IP over WDM network architecture. Section III shows TV viewing behavior and program popularity which leads us to propose, in Section IV, our time-based content replacement strategy. Section V then describes how we evaluate the proposal. We describe the two physical topologies that we use as test networks and the MILP model and simulation models used to evaluate the strategy. In Section VI we evaluate the power consumption of content replacements using our MILP model and simulation with both fixed and variable caches. Section VII evaluates the effect of regular traffic on power efficiency. Section VIII explains the significance of our model with respect to current and future networks. Finally Section IX provides the main conclusions.

II. IPTV DELIVERY OVER AN IP OVER WDM NETWORK

This section describes IPTV service delivery.

A. IPTV Delivery

A typical IPTV network consists of three main parts: (a) the content delivery network, (b) the access network and (c)

the transport network. Fig. 1 shows the network architecture of a typical IPTV network.

Content Delivery Network

The content delivery network (CDN) includes the data center which is made up of the content storage and server components. The CDN also includes the video head-end (video server), responsible for transforming video streams into digital compressed streams that are encapsulated in IP packets and injected in the core network. These video streams may be live TV broadcast or VoD libraries. One encoder is required at the video head-end for each TV channel, and possible output streams are standard definition, high definition and picture-in-picture [1], [11]. The CDN also includes caches, which may be deployed throughout the network.

Access Network

In order to support high bandwidth services, Passive Optical Networks (PON) or Fiber to Cabinet (FTTC) networks are becoming the leading choice for access. These technologies provide connections from the aggregation switch in the network to the user premises. An Optical Network Unit (ONU) (or a VDSL modem) at the user premise terminates the access line and generates the Ethernet signals which are then passed to a Set-Top-Box (STB) connected to a TV. The STB has an embedded operating system, and can decode the video to be viewed on a TV [11].

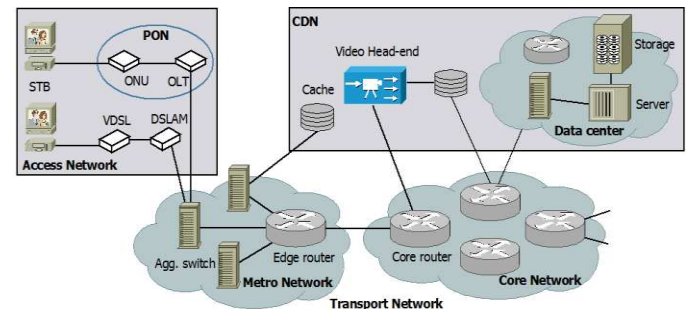

Fig. 1. IPTV network model

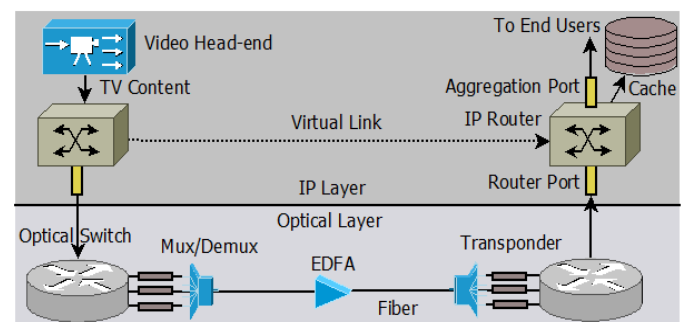

Fig. 2. A simple 2-node IP over WDM network architecture

Transport Network

All switching, distribution and aggregation is considered part of a transport network. The transport network consists of core routers, edge routers and aggregation switches interconnected through Wavelength Division Multiplexing (WDM) optical transport technology [11], [12]. This area is

particularly significant as this is the area in which energy savings are sought.

B. IP over WDM

WDM offers many attractive features including high capacity, reduced cost and the ability to minimize the number of switching hops in the network. Therefore, IP over WDM is expected to continue to play an important role in the next generation Internet [13]. A simple architecture of the transport network with two nodes is shown in Fig. 2.

Each physical link between a pair of optical switches includes one or more fibers equipped with a pair of multiplexer/demultiplexers, a pair of transponders and a number of optical amplifiers (Erbium Doped Fiber Amplifiers, EDFAs) depending on the length of the link. The number of EDFAs required on each fiber is: $\lfloor D_{ij}/S - 1 \rfloor + 2$, where D_{ij} is the distance between nodes i and j , S is the EDFA spacing and $\lfloor \cdot \rfloor$ is the integer part [14].

When implementing IP over WDM, an optical switch may also be used to provide lightpath bypass. This enables traffic to bypass the IP router of any intermediate nodes. Under lightpath non-bypass, all the IP routers of intermediate nodes on the path are traversed. Lightpath bypass is considered more energy efficient, as IP router ports consume relatively high power [14]. However, most networks currently employ non-bypass routing which enables the operator to access data at intermediate nodes for security, deep packet inspection and error correction. Therefore in this work we assume lightpath non-bypass routing.

C. Video Delivery

The IP aggregation switch distributes aggregated traffic to the access connection. If the aggregation node is equipped with a cache then videos stored in the cache can be sent directly to the access network. In the case where no cache is deployed at the node or the video is not stored in the cache, the video is streamed across the transmission network from the appropriate video head-end using optical transmission paths.

III. TV PROGRAM POPULARITY

In this section we examine the daily viewing figures of TV programs and program popularity. We use this to motivate our proposed cache management scheme.

Measuring TV viewing and its distribution over a day provides information about likely IPTV traffic demand and its variation over time. The similarity of TV viewing is higher when more viewers prefer to view the same program. This measurement is useful to estimate the potential reduction in network traffic due to caching, as the popularity of each program stored in the cache is used to find the cache hit ratio. TV viewing behavior can also be used to calculate the required cache capacities to achieve a desired cache hit rate.

To carry out our evaluation, we examine the number of viewers of the most popular TV programs during a day. These figures are mapped against the total number of viewers at each time of the day. We obtained TV viewing data from Friday 9th November 2012. The number of viewers for each TV program and the times these programs are aired are collected from [18] and [19], respectively. A viewer of a TV program is considered among the program audience if the viewer watches

3 minutes or more of the program. The number of viewers of the most popular TV programs is based on a sample of viewers. The total number of viewers is the average daily viewing of all TV channels measured over November 2012 [18], [20]. The number of viewers per TV program is used to calculate the popularity of the program and hence its potential contribution to the network traffic due to user requests.

Fig. 3 lists the most popular TV programs and their corresponding broadcasting TV channels as well as the number of viewers for each program in the UK. It also plots the total number of TV viewers during the day, and therefore can be used to estimate the amount of traffic devoted to the most popular programs.

The most popular TV programs would account for a significant portion of network traffic, particularly at primetime. This observation justifies the use of caching the most popular TV programs to reduce the duplicate traffic and therefore reduce the power consumption of transport. Moreover, requests for other TV Catch-up services (CuTV) such as the BBC iPlayer and Channel 4 on Demand (4oD) can be served from content already stored in caches.

It is worth mentioning that mainstream TV today is usually broadcast over the air and where scheduled TV is delivered over IP, IP multicast is the technology of choice. However, two recent trends motivate us to consider cache solutions:

- Firstly, whilst viewers prefer to watch scheduled TV, they increasingly expect more control over the timing of their viewing – to be able to start a program slightly late (a need that is driving the +1 channels) or to pause a viewing temporarily[21].
- Secondly, there is a rise in emerging rich streaming space served by YouTube live streams, Twitch.tv, etc. which have already attracted millions of viewers.

Little is known yet about user behavior and content popularity of these services, leaving mainstream TV data the closest available alternative. We believe that mainstream TV viewing patterns can be a good reflection of future IPTV viewing patterns as, despite the availability of CuTV, most users prefer to watch TV close to schedule. The use of social media to communicate between friends whilst watching TV may in part be driving this trend.

We can however identify that certain types of programs may be less suited to a cache solution (e.g. live sports). Therefore, it is important to estimate the proportion of live content to decide if caching is beneficial. We obtained the number of TV programs broadcasted on 91 major UK channels from [22] and so calculated the number of live and non-live TV programs shown between the 14th and the 20th of September 2013. Our methodology includes basic channels in addition to entertainment, documentary, lifestyle, films, sport and children channels. In total 14323 TV programs were aired during the time considered. Of these, 322 were live shows, accounting for only 2.25% of broadcast TV programs.

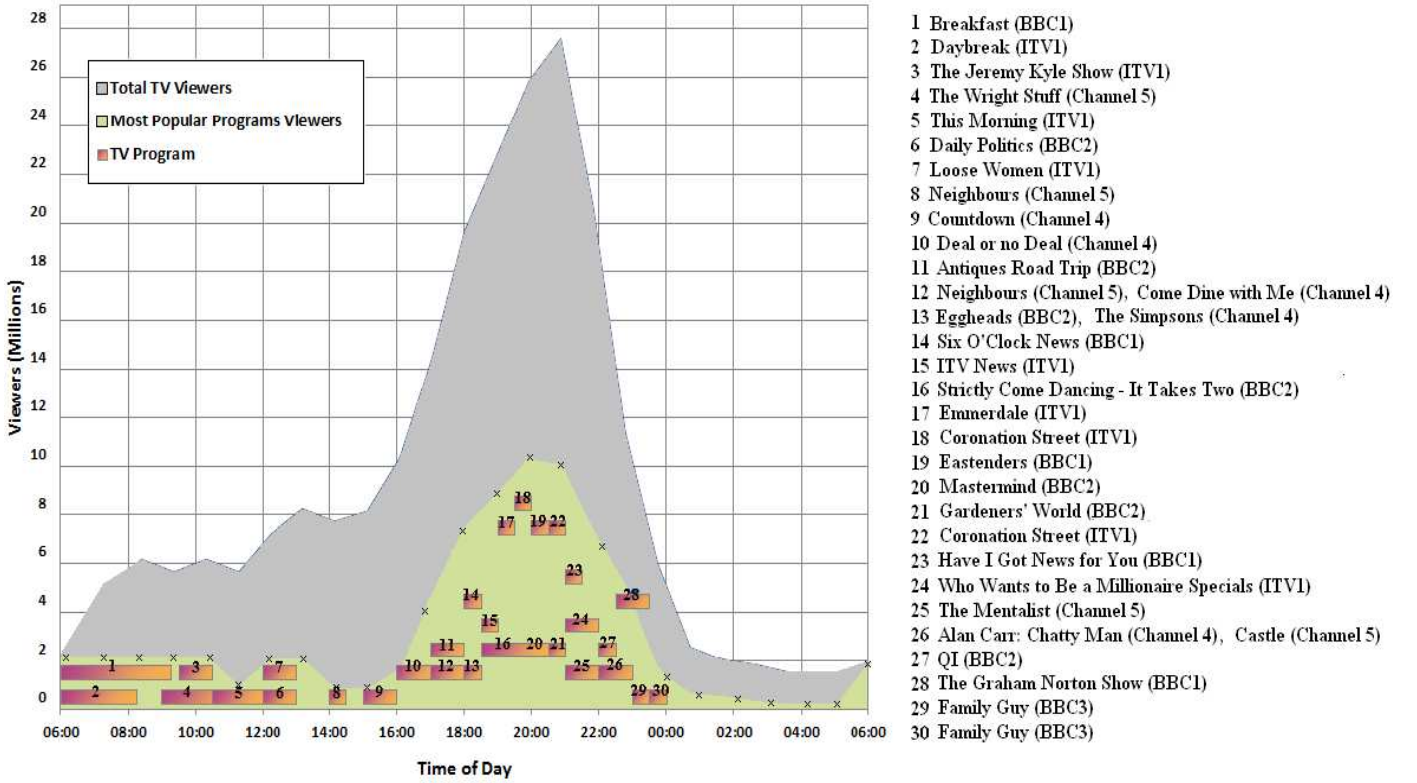

Fig. 3. The average daily TV viewing figures, the most popular TV programs and their number of viewers at each time of the day viewed on Friday November the 9th 2012

IV. TIME-BASED CONTENT REPLACEMENTS

A. Overview

In our previous work we have shown that caching data can enable reductions in total energy use. This energy optimisation occurs when the cache ratio is high (reducing the energy of the transport network) and the cache small (constraining the energy of the cache). In this section, we propose a novel time-based content replacement algorithm to maintain high cache hit rates and small cache sizes as object popularities change. The algorithm is based on the fact that object popularities are both time dependent and predictable. Cache content replacements are therefore performed with respect to time-based object popularities to maximize cache hit ratios whilst minimising the required cache size.

B. Details

For a given TV program, we are interested in three quantities with respect to viewing popularity: (i) the program average popularity over all time which determines the significance of caching the program, (ii) the instantaneous popularity that shows the dynamics of viewing the program over time, and (iii) its popularity over a time window which is useful when cache content replacements are considered.

Assuming a popular program which is, for example, primarily viewed in the morning and hardly viewed during other hours of the day, the average popularity P_i of this program is given as:

$$P_i = Req_i / Tot_Req \quad (1)$$

where Req_i is the number of requests to program i and Tot_Req are the total requests. Note that Req_i and Tot_Req are measured over the same time duration. If this time duration is long and the process is stationary then P_i converges to its actual probability of that event.

We next consider the popularity of a program over a time window from time $t=a$ to time $t=b$ to signify a duration in time over which cache contents remain the same. The popularity of program i during the time from a to b $P(i,a,b)$ is calculated as the ratio of the sum of requests for the program throughout the time duration from a to b to the total requests taking place during the same time duration,

$$P(i, a, b) = \frac{\sum_{t=a}^b Req_{it}}{\sum_{t=a}^b Tot_Req_t} \quad (2)$$

Let $\beta(i,a,b)$ be a factor that specifies how requests for program i are distributed over time and is given as the ratio of the number of requests for program i over a time window to the overall number of requests, or:

$$\beta(i, a, b) = \frac{\sum_{t=a}^b Req_{it}}{Req_i} \quad 0 \leq \beta \leq 1 \quad (3)$$

where $\beta(i,a,b)=1$ implies that all requests for program i occur in the considered time window and the value of $\sum_{t=a}^b Req_{it}$ reaches its maximum $\sum_{t=a}^b Req_{it} = Req_i$. Consequently program i must be stored in the cache for the time duration from time $t=a$ to time $t=b$ (assuming that the program's time-driven popularity ranks at the top of the programs' popularity list). In the other extreme when the value of $\beta(i,a,b)$ is 0, program i is never requested in the considered time duration, since $\sum_{t=a}^b Req_{it}=0$. Although this program might have a high global popularity, having the program in the cache during the

particular duration of time from a to b is not useful. The number of daily content replacements to be performed influences the resultant time-driven program popularity $P(i,a,b)$ by determining the lengths of considered time windows. Note that time t is a continuous variable and therefore Equation (2) and (3) can be calculated using integrals. In our evaluation however, the number of program requests are grouped at the start of each hour of the day, thus a summation provides an accurate approximation.

The cache hit ratio H is the ratio of the number of requests served from the cache to the total number of requests,

$$H = Req_{cache} / Tot_Req \quad (4)$$

where Req_{cache} is the number of requests served from the cache. The cache hit ratio is also calculated from the summation of the popularities of programs stored in the cache,

$$H = \sum_{i=1}^M P_i \quad (5)$$

where M is the cache size in programs. Considering content replacements, the time-driven cache hit ratio during a time window from time $t=a$ to time $t=b$, $H(a,b)$, is derived from the sum of the time-driven popularities of programs $P(i,a,b)$ stored in the cache during that time window,

$$H(a,b) = \sum_{i=1}^M P(i,a,b) \quad (6)$$

The cache hit ratio can be considerably increased by performing content replacements, since a replacement populates the cache with programs which are highly relevant during the considered time window. Such programs replace programs which are hardly viewed during that time window thus removing programs with lower values of $P(i,a,b)$. This strategy acts on shorter time spans and is therefore more effective (in terms of the required cache size and therefore its power consumption) than conventional approaches which use the global popularity P_i .

V. EVALUATION METHOD

We have developed Mixed Integer Linear Programming (MILP) models to find the optimum number of daily replacements in order to minimize power consumption. We also have also developed a simulation which we can use to validate the results of this model. We apply the model to two test networks topologies (NSFNET and BT 21CN) considering both SD and HDTV.

A. The MILP Model

We have created two MILP models, one for fixed and one for variable caches. These models, highlighted below, are described in detail in the Appendix.

1) Content Replacement MILP Model Assuming Caches of Fixed Size

The optimum number of daily replacements that achieves the best power efficiency is a tradeoff. Infrequent replacements lead to low cache hit rates and so high power consumption associated with viewing TV from the head-end, whereas frequent cache updates waste energy through populating the cache unnecessarily. We model the optimum

number of cache updates, using the network components described in Section II and the program popularities of Section III. This model assumes that the cache size is fixed.

2) Content Replacement MILP Model with Variable Caches

This model extends the first model by introducing caches that can reduce their active capacity. A smaller cache will draw less energy but will be able to store less data. We obtain the relationship between the number of programs stored in the cache and its hit ratio. This relationship is represented by a convex function. However, cache hit ratios vary with the difference in the number of daily content replacements, requiring a different convex function for each considered number of replacements. Therefore, our goal is to find the optimum cache size for each node at each time of the day under each number of daily replacements.

3) MILP Implementation

The MILP models use dual simplex iterations to find the optimum and defines around 1 million variables and over 3.6 million variables in the NSFNET and the BT 21CN topologies respectively. The models were solved using AMPL/CPLX on a Pentium(R) Dual – Core CPU at 2.8 GHz with 3 GB RAM. A typical run of the content replacements model required between 20 and 30 minutes for the NSFNET and 4 hours for the BT 21CN network.

B. The Simulation Approach

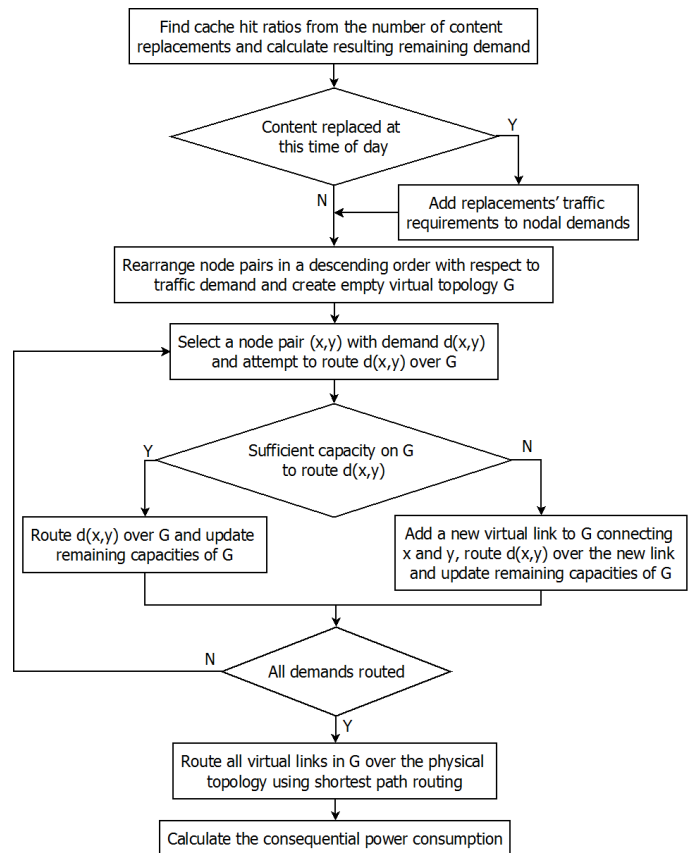

Fig. 4. The content replacement algorithm flow chart

In order to validate our proposed MILP model we also developed a simulation to calculate the power consumption of

the system. The routing algorithm of the simulation is based on the heuristic proposed in [14] where traffic is routed over an IP over WDM network considering lightpath bypass. This algorithm is extended to include caches and consider non-bypass.

1) Demand calculation:

The content replacement process, shown in Fig. 4 starts by obtaining the hit ratios of deployed caches using the optimum number of replacements found by the content replacement MILP model. Using these cache hit ratios, the network traffic demand is calculated. The algorithm then checks if content is to be replaced at the current time of day according to the number of replacements. If so, the additional traffic demand due to content replacements is added to the total traffic entering each node.

2) Routing traffic over the virtual layer:

The algorithm continues by arranging node pairs in a descending order starting with the node pair having the highest demand to accommodate high demands on virtual links first and try to accommodate lower demands on the same existing links. An empty topology G is created to record established links and their capacities. The node pair (x,y) with the highest demand $d(x,y)$ is selected and the algorithm attempts to route $d(x,y)$ over existing virtual links. If the capacities of existing virtual links in G are sufficient to accommodate $d(x,y)$, the process is successful and the remaining capacities of G are updated. Otherwise, a new virtual link connecting x and y is created and added to G . The demand $d(x,y)$ is routed over the new link and the remaining capacities of G are updated. The selection of node pairs is repeated until all demands are routed.

3) Routing traffic over the physical layer:

When iterations are complete, G holds the set of lightpaths to be routed over the physical topology in the optical layer. The simulation uses the shortest path routing algorithm to route the lightpaths over the path with the shortest physical distance in the physical topology. The shortest physical distance minimizes delay but does not necessarily result in the minimum usage of network components, and consequently minimum total power consumption. For example the path with shortest physical distance may traverse more intermediate nodes compared to a slightly longer path and therefore consumes more power in this case. It minimizes delay however (and in general is a good choice for power minimization) and is therefore chosen here [15]-[17]. The alternative minimum hop routing approach may result in lower power consumption, but higher delay and is therefore not adopted in this study. In the IP layer, the number of ports required to accommodate the capacities of lightpaths is calculated, and the power consumption of the IP layer is found.

The algorithm allows grooming where more than one demand may be routed on the same virtual link, and therefore improves virtual link utilization. This feature results in decreasing the number of established virtual links and hence fewer IP router ports are required. Since router ports are the network major power consuming components, the overall power consumption is reduced.

C. Test Networks

We consider two physical topologies as test networks. The NSFNET topology is selected as a communication infrastructure widely used in network studies. This approach enables other researchers to compare their work to ours.

We also include the UK BT 21CN network since the TV viewing data used in our evaluation is based on UK audience. We provide original analysis on the BT 21CN topology as not much research has been reported on this network.

Considering these two topologies allows comparison between a European network where population densities are high and an American network with large distances between content locations.

1) The NSFNET Topology

The NSFNET topology of 14 nodes and 21 links is shown in Fig. 5, with distances between nodes given in kilometers. We assume that a video cache is available at each node in the network. With respect to the number and location of video head-ends in the network, we consider three options:

A Single Video head-end with Minimum Delay Location (NSF-SVMD):

The location of the video head-end is optimized such that the propagation delay to end users is minimized. Other end-to-end delays are not considered here as they are proportional to the amount of streamed video traffic. The location of the video head-end under NSF-SVMD is node 5 in NSFNET. The optimum locations of the video head-ends assuming no caching were obtained using our previous work [4], [5] and [15]. This required that we set the server location indicator as a variable rather than a parameter. The previous MILP model was re-run (using the input values described in Section D) to find the optimum server locations with respect to the total number of servers in the network and the target parameter (delay here and power consumption for the next two options). The resulting locations are subsequently used as inputs to the content replacement MILP model.

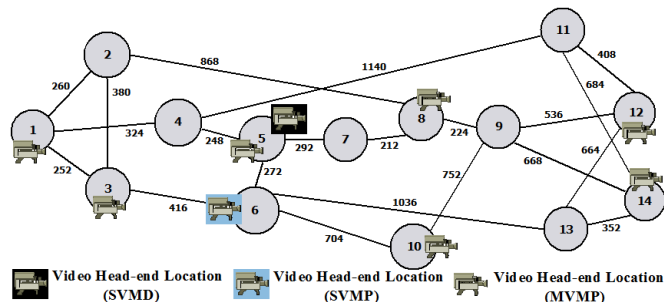

Fig. 5. The NSFNET topology with video Head-end locations under SVMD, SVMP and MVMP and fiber length in kilometers

A Single Video head-end with Minimum Power Location (NSF-SVMP):

The location of the video head-end is optimized to minimize the power consumption of the network. Unlike in SVMD where the distance between nodes is the dominant factor in finding the optimum location of the video head-end, here minimizing the number of hops that content traverses from source to destination is the key element under SVMP. This is explained by the fact that the most power consuming network components are routers which are utilized at each hop in the communication path. The optimum location

of the video head-end under NSF-SVMP is node 6 in NSFNET.

Multiple Video head-ends with Minimum Power Locations (NSF-MVMP): We further consider an evolution where 7 video head-ends are assumed each injecting unique content into the core network. This is the most complex yet realistic scenario. Video providers such as Google and YouTube employ multiple data centers. Google has 19 data centers in the US alone [23] whilst YouTube has 6 data centers excluding the CDN [24]. The locations of video head-ends are optimized using the models in [15] to minimize the overall network power consumption. Since no content replication is considered among video head-ends, the comparison of NSF-SVMD, NSF-SVMP and NSF-MVMP is not directly possible.

2) The BT 21CN Topology

The BT 21CN (British Telecom 21st Century Network) is a Next Generation Network (NGN) implemented by BT. Its core topology shown in Fig. 6 consists of 20 nodes and 68 links. Core nodes are divided into inner core nodes (8 nodes) which are fully meshed and outer core nodes (12 nodes) which are connected to at least three other core nodes [25]. In order to determine the topology information required to carry out our investigation we obtain the network core node connectivity from [25] and the core node locations from [26]. We consider three topologies under BT 21CN with respect to server location:

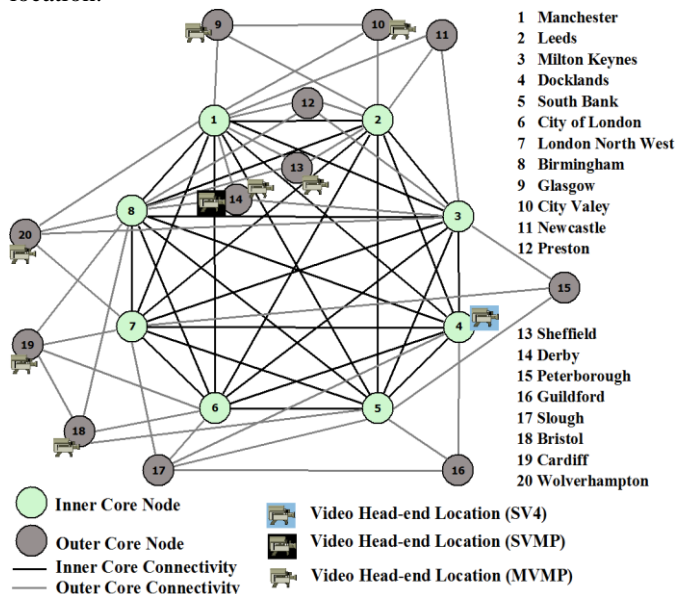

Fig. 6. The BT 21CN topology with inner and outer core node locations

A Single Video head-end at Node 4 (BT 21CN-SV4): This approach represents the current network situation as Telehouse located in Docklands (node 4) is the major peering location for the UK.

A Single Video head-end with Minimum Power Location (BT 21CN-SVMP): Similar to the method we employ under the NSFNET topology, we find the location of the single video head-end that minimizes the power consumption. We find that this location is node 14.

Multiple Video head-ends with Minimum Power Locations (BT 21CN-MVMP): we find the locations of 7 video head-

ends in the network that minimize total power using the same approach used under the NSFNET topology. These locations are node 9, 10, 16, 14, 18, 19 and 20. The locations of video head-ends under all considered topologies are shown in Fig. 6.

The two network topologies considered are small. Nevertheless, note that our work is concerned with core networks and they are typically of this size. We plan in the future to develop heuristics based on our MILP model insights and apply such heuristics to larger networks.

TABLE I compares the NSFNET and BT 21CN topologies in terms of coverage, average hop count and average nodal degree.

TABLE I. COMPARISON OF THE NSFNET AND BT 21CN TOPOLOGIES

Property	NSFNET	BT 21CN
Coverage	Continental	National
Average hop count	1.7	1.8
Average nodal degree	3	6.6

D. Input Parameters

TABLE II. INPUT DATA FOR THE MODEL

Distance between two neighboring EDFAs (S)	80 (km)
Number of wavelengths in a fiber (W)	16 [14]
Capacity of a wavelength (B)	40 (Gb/s)
Power consumption of a router port (Pp)	604 (W) [29]
Power consumption of a transponder (Pt)	73 (W) [14]
Power consumption of an EDFA (Pa)	8 (W) [28]
Power consumption of an optical switch (Po)	85 (W) [30]
Power consumption of a multiplexer/demultiplexer (Pmd)	16 (W) [27]
Power consumption of a cache (Pc)	7.4 (W/GB)

The power consumption parameters used in the evaluation are shown in TABLE II. The power consumption of an 8-slot CRS-1 is 4834 W [29]. Each slot can contain one 40Gb/s port and therefore the power consumption of a 40 Gb/s router port is estimated at 604 W [14].

In [31], the energy consumption of data streaming (read / write operation) is given as 211×10^{-9} (J/b). We convert this value into the power in Watts consumed to stream 1GB of data over a given time duration, to utilize in our MILP model. The energy consumption of 1GB of data is: $211 \times 10^{-9} \times 10^9 \times 8 = 1688$ J/GB. The typical maximum access data rate for a fiber channel hard disk is up to 100MB/s. However, the typical average data rate is around 50% of that value and is up to 50MB/s [32]. Higher hard disk access speeds reduce the cache update time, but lead to higher power consumption. We consider a lower hard disk data rate of 35MB/s to achieve reasonable power consumption. The time required to stream 1GB becomes: $10^3 \times 8 / 35 = 228$ seconds. Consequently the power consumption of caching is $1688 / 228 = 7.4$ W/GB. Note that the 228 seconds streaming time results in one 1-hour TV program being delivered in approximately 2.5 and 17 minutes under SDTV and HDTV, respectively. To reduce this time for example to 1 minute under HDTV, 17 parallel disks are required, however the hard disk access speeds continue to improve and access speeds below 1 minute in this case may become possible in the near future. Caches are in the READ state as long as no replacements are performed. During a replacement, the portion of the cache being replaced enters the WRITE state for a very short time (a few minutes vs. 24

hours). We consider the power consumption of a READ or WRITE state to be the same.

To generate the network video traffic demand, we assume that all the TV viewing of Fig. 3 is carried over an IP network, at standard or high definition rates. For simplicity, we assume that user requests are equally distributed among the nodes. A more complex approach is to distribute user requests with respect to population density which requires further investigation.

Assuming the compression standard MPEG-4 AVC (Advanced Video Coding), the Digital Subscriber Line Forum (DSL Forum) recommends bit rates between 1.5Mb/s - 3Mb/s for SDTV and 8Mb/s - 12Mb/s for HDTV [33]. Here we assume 1.5Mb/s for SDTV and 10Mb/s for HDTV producing 1-hour TV programs of size 675MB and 4.5GB under SDTV and HDTV, respectively. Although MPEG-4 AVC is not as widely deployed as MPEG-2, it is expected to become more commonplace as it delivers up to 50% bit rate savings, offering better bandwidth utilization, deployment of advanced HDTV services and lower power consumption.

We use the number of viewers of each TV program and the total viewers to calculate program popularities. Note that the most popular TV programs shown in Fig. 3 account for only a trivial number of the entire TV programs broadcasted on the day (30 out of over 2000 programs). To obtain the popularity of additional TV programs, we created a model based on the popularities of the 30 most popular programs which was used to estimate popularity values for the additional 300 programs which are utilized in our evaluation. Since the popularities of less popular programs are insignificant compared to the 30 most popular programs the consequent error due to the estimation is negligible.

The TV viewing data we utilize is based on UK audience. US TV program popularity and viewing data are not available in public domain to the best of our knowledge. Therefore we apply the same TV traffic demand derived from Fig. 3 to both network topologies (BT 21CN and NSFNET).

VI. CONTENT REPLACEMENTS POWER CONSUMPTION EVALUATION

We have used the MILP models and the simulation explained in Section V to evaluate the power consumption of the two network topologies considered. In this section we present the results.

A. Content Replacements with fixed size caches

1) Motivation:

We have shown previously that caching can reduce transmission energy for programs that are popular, but wastes caching energy when programs are less popular. We have also shown that there is an optimal cache size in that a small cache uses less energy but can store fewer of the popular programs. We have seen in section III that programs have a strong time-dependent popularity. In particular, programs are most popular around time of original broadcast. This means that the most popular programs at any point in time can be predicted. This then gives us a strategy to manage content on the cache enabling us to minimize both cache and transmission system energy use.

2) Method:

Ignoring the time dependent aspect of program popularity we first used our previous models [4],[5] to calculate the cache size that would minimize power consumption using the observed object popularity distribution. This was found to be 200 GB and 650 GB (fixed-size caches) for SDTV and HDTV respectively. We then calculate the popularity of each program with respect to time windows using Equation (2) and the traffic profile in Fig. 3. The values for program popularities are used to find the cache hit ratio from Equation (6). Each program is assumed to have a fixed number of viewers for the program duration and to have no viewers outside broadcasting time. To include consideration of CuTV or time-slipped viewing, a non-zero popularity could be assigned to each TV program after the end of broadcasting. Since the contents of the cache are never entirely replaced, our approach is conservative as CuTV would lead to higher cache hit ratios than we calculate here. However, this traffic is currently small compared to TV traffic [20]. The influence of CuTV viewing on cache hit ratios will become visible when CuTV traffic reaches considerable levels.

When a content replacement is performed, the new cache content is streamed from the video head-end to the cache resulting in additional traffic passing through the network. The amount of traffic is a function of the percentage of the cache size that is replaced. It is possible that only a fraction of the cache is updated with each replacement as some programs may remain popular through two or more time windows. Here we assume that the entire cache contents are replaced each time. This assumption has the advantage of achieving a high cache hit ratio as the cache is occupied with the most popular programs for the considered time duration. However, the shortcoming is that more traffic passes through the network to fill the cache when a replacement occurs. This assumption allows us to evaluate the full effect of additional traffic introduced by content replacements and therefore the power savings we report are conservative.

We assume that it takes time to update the cache contents and use this time delay to calculate the additional network traffic in Gb/s. The cache update time should be much shorter than the minimum replacement interval (2 hours). In addition, the resulting data rate should not over-load the network. We therefore select a cache update time of 1 minute which leads to cache update traffic of 26.6 Gb/s and 86.6 Gb/s under SDTV and HDTV, respectively. The cache update traffic is much smaller than the overall network traffic (40 Tb/s). A more sophisticated scenario for cache updates may be considered where only sections of the cache are updated. For example, it might be more power-efficient to replace only 20% of the programs during content replacements performed in the early hours of the morning, whereas updating 100% of the cache becomes necessary at primetime to achieve maximum power savings. A more practical approach can also be considered where the list of the most popular programs during the next time window is compared to the list of the most popular programs currently stored in the cache. Only the TV programs which are not already in the cache are streamed from the video head-end. This strategy results in communication overhead where the knowledge of the up-to-date cache contents is

required. Such complex refinements warrant further investigation.

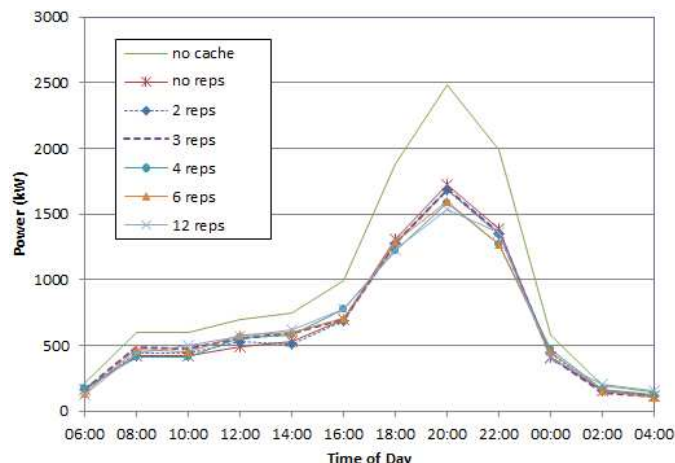

Fig. 7. Power consumption of watching TV programs with no caching, fixed optimum caches and under 2, 3, 4, 6 and 12 daily content replacements considering SDTV NSF-MVMP

3) Power consumption evaluation:

In order to evaluate the power consumption of the network under various daily replacements we compare replacement frequencies of 2, 3, 4, 6 and 12 per day. The MILP model is solved considering the NSFNET topology under SVMD, SVMP and MVMP and for the BT 21CN topology under SV4 and SVMP. In Fig. 7 we show the resultant power consumption of the NSF-network for SDTV compared to the power consumed when no caches are deployed in the network. The largest savings in power consumption are achieved when 12 content replacements are performed. Nevertheless with a fixed cache size, content replacement gives little benefit over a cache that is populated once a day as there is only a marginal increase in cache hit ratios. The largest instantaneous power savings of 48% were seen for the BT 21CN topology under HDTV and MVMP.

B. Content Replacements under Variable Caches

Our goal here is to investigate the additional savings possible by using variable sized caches.

1) Cache hit ratio dynamics:

To carry out our investigation, we again find the popularity of TV programs to obtain the relationship between the number of programs stored in the cache and its hit ratio. The popularity of each program is different under each of the considered daily replacement schemes and at each time of the day, so cache hit ratios will vary with time. Each equation that describes the relationship between the number of programs stored in the cache and its hit ratio under a certain replacement frequency is a concave function. The combination of all equations representing all considered number of daily replacements form a surface. In Fig. 8 we show two examples of this relationship at time 6:00 and 20:00. From each resulting surface, we calculate a piecewise linear approximation under each considered daily replacement frequency. All piecewise linear approximation equations are input to the MILP model to calculate cache sizes from optimum cache hit ratios rather than finding the cache hit ratio

from the cache size as in Fig. 8. Therefore the relationship described in the MILP model is a convex function.

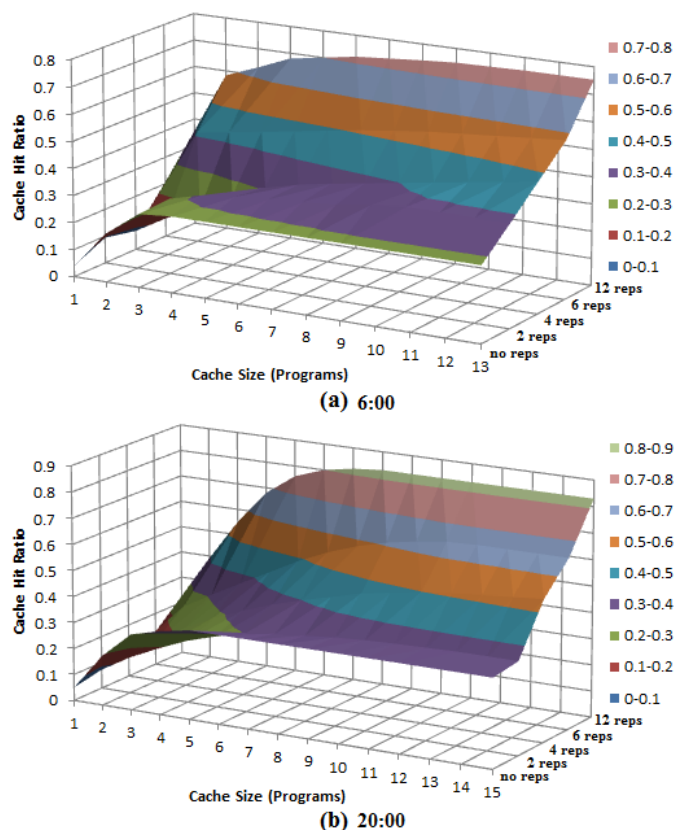

Fig. 8. The relationship between the number of TV programs stored in the cache, the number of daily content replacements and the cache hit ratio at time: (a) 6:00 and (b) 20:00

The resulting surfaces shown in Fig. 8 (a) and (b) show that the hit ratios of variable caches increase with the increase in the number of content replacements performed. When no content replacements are performed, increasing the cache size leads to increasing the cache hit ratio. When further increasing the cache size, the cache hit ratio saturates as programs become less popular.

If the cache is of fixed size, then at any point in time it is storing programs which are not needed at that time. Under content replacements, the cache stores programs which are viewed during the current time window and thus the whole cache is usable. This explains the few dips in cache hit ratio that can be observed in Fig. 8 where at a number of points the cache hit ratio under replacements becomes lower than the cache hit ratio under fixed, yet entirely effective.

2) Power consumption evaluation:

In Fig. 9 we show the power consumption of the NSF-MVMP generated by the MILP model. This shows that, with variable cache sizes, there is now a significant benefit from having frequent content replacement. The savings are greatest during primetime when the traffic volume is high and there are only a few very popular programs.

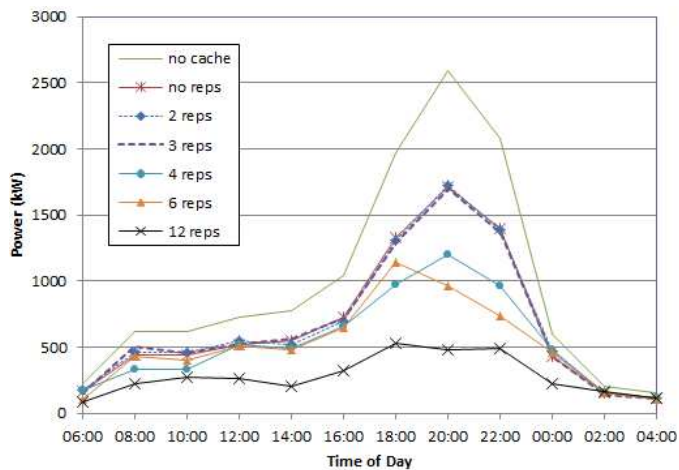

Fig. 9. Power consumption of watching TV programs with no caching, variable cache sizes with no content replacements and under 2, 3, 4, 6 and 12 daily content replacements considering SDTV NSF-MVMP

The peak and average savings in power consumption due to content replacements performed on caches with variable sizes are shown in Fig. 10. The maximum savings range between 80% and 82% for the NSFNET topology and up to 85% for the BT 21CN topology. These savings are significantly greater than the savings when we have a fixed cache size.

We make the following observations:

- The greatest savings in energy consumption are achieved by performing 12 daily replacements on cache contents (see Fig. 9).
- When deploying caches of fixed and variable sizes in the network with no content replacements, the maximum power savings achieved are moderate and are similar to the average power savings (calculations based on Fig. 7).
- Under time-based content replacements the cache hit ratio varies over the day, resulting in varying savings in power consumption (see Fig. 11).
- Variable cache size gives benefit as the optimal cache size is different depending on the traffic volume. As a result, when performing replacements on variable cache sizes, the maximum power savings achieved are much higher than the average power savings. The greatest power savings are achieved at primetime where traffic is high and a small number of programs are very popular (see Fig. 7. and Fig. 9).

3) Comparison of the two network topologies:

It can be observed in TABLE I that the two topologies (NSFNET and BT 21CN) are similar with respect to hop count, but are different in terms of the coverage area and nodal degree. Average power savings of caching (with no content replacements) are 30% – 31% and 33% – 35% under NSFNET and BT 21CN, respectively. The average power savings introduced by content replacements are 68% – 74% and 70% – 77% under NSFNET and BT 21CN, respectively. The coverage area of the network does not influence the power consumption much as the additional distance between nodes

requires extra EDFAs which do not consume significant power (8W). Consequently, we achieve comparable power savings under all cache management techniques in the two topologies. The slight further improvement in power savings under the BT 21CN topology is due to the higher nodal degree which provides more possible paths through which traffic can be routed without underutilizing resources (in our model the path that achieves the most power saving is selected). The consideration of two network topologies (the NSFNET and BT 21CN) in our evaluation helped generalize the results. Although there are slight differences, there is good consistency in the results giving confidence in the methods developed.

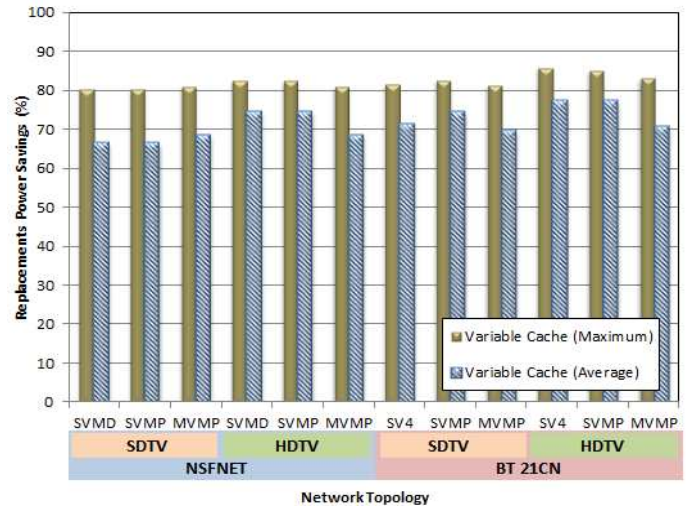

Fig. 10. Maximum and average power savings of content replacements using variable caching under SDTV and HDTV considering SVMD, SVMP and MVMP (NSFNET) and SV4, SVMP and MVMP (BT 21CN)

4) Optimum variable cache sizes:

Fig. 11 shows how the cache hit ratios change due to content replacements when cache sizes can be varied over the day. The increase in the number of daily content replacements leads to an increased cache hit ratio. The average cache hit ratio increases from 0.32 to 0.69 and 0.7 under SDTV and HDTV, respectively. These increases in cache hit ratios are the primary driver for the reduction in power consumption.

We see that it is not guaranteed that the cache hit ratio will increase at each time slot with the increase in replacement frequencies. For instance, the average cache hit ratio at 18:00 when performing 4 and 6 replacements is 0.5 and 0.39, respectively. This results (as shown in Fig. 9) in the network power consumption with 6 replacements being higher than that with 4 replacements for that particular point in time. However, the total energy consumption of the network reduces with increase in the replacements frequency, including that additional power consumed to replace content.

The optimum variable cache sizes over the time of the day found by the model follow the daily trend of input traffic. These cache sizes are averaged over network nodes and are shown in Fig. 12. Performing content replacements on smaller caches achieves higher cache hit ratios than deploying variable cache sizes with no content replacements. When a single video head-end is considered in the network the average cache size falls from 320 GB to 51 GB and from 2058 GB to 443 GB

(variable cache sizes) under SDTV and HDTV, respectively. In other words, the power savings in caching are an average of 84% and 78.4% under SDTV and HDTV, respectively.

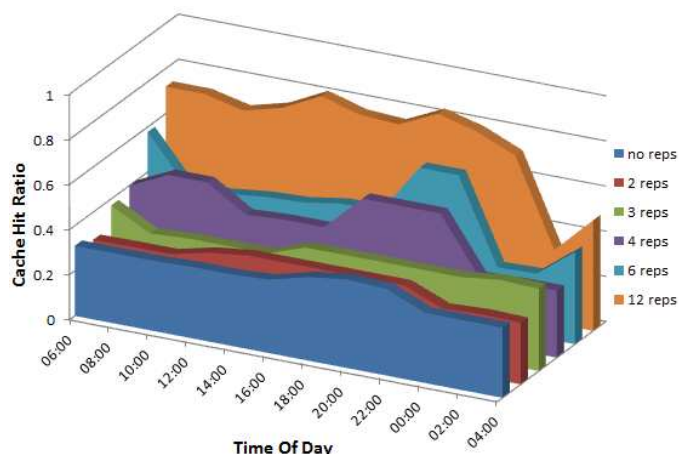

Fig. 11. Cache hit ratios of optimum cache sizes averaged over network nodes with no content replacements and considering 2, 3, 4, 6, and 12 daily content replacements under SDTV NSFNET with a single video Head-end

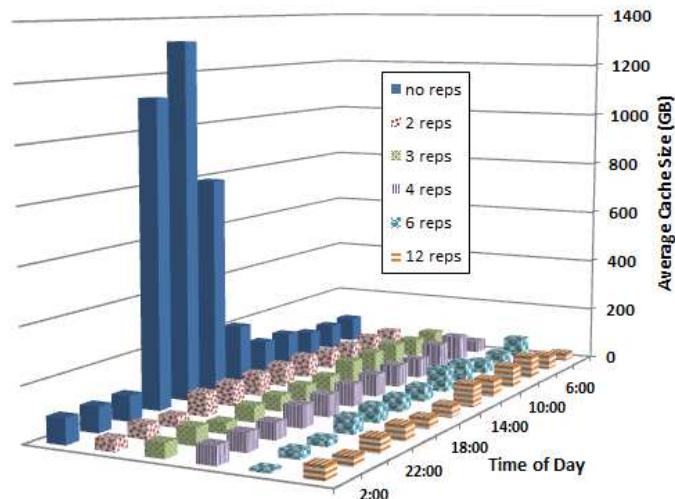

Fig. 12. Optimum variable cache sizes averaged over network nodes with no content replacements and considering 2, 3, 4, 6, and 12 daily content replacements under SDTV NSF-SVMP

The results on cache savings are only accurate when the number of replacements is high (e.g. 12 replacements). Considering variable caches sizes, it is assumed that by caching the N most popular programs and by obtaining a cache hit ratio of H , this cache hit ratio remains effective all day. In reality, the N most popular programs may be evening programs and in real time TV there is no interest in them in the morning. Therefore in Fig. 12 for example, the variable cache size at 2:00 should be zero since the most popular programs are evening programs that are cached, but are not relevant in the morning. With the increase in the adoption of CuTV and iPlayer type services, this approximation becomes valid as popular programs remain popular and available to play for extended hours and may be for few days (one week typically for iPlayer). For the approximation to be accurate, popular programs must remain popular all the time, with no real time TV effect. In addition, programs need to be available to stream at any time of the day.

5) Simulation Results:

Fig. 13 shows the total energy consumption of the network under SDTV and HDTV using both MILP models and simulations.

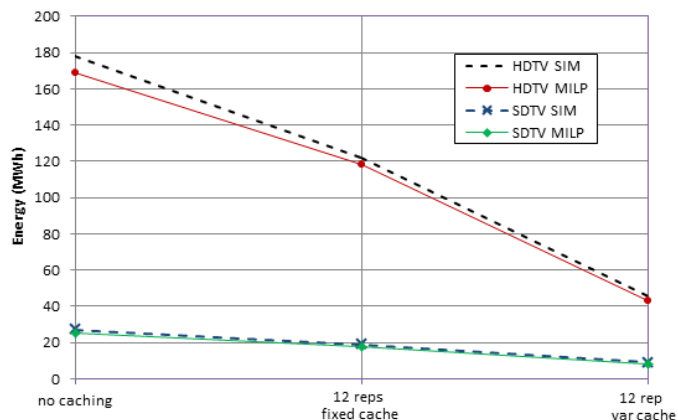

Fig. 13. The daily energy consumption of watching SDTV and HDTV programs when no caches are deployed and when 12 daily replacements are performed on fixed and variable caches under NSF-SVMD using the MILP model and simulation

To run the simulation considering content replacements on caches of fixed sizes, the cache hit ratios are calculated considering the number of daily replacements, and these cache hit ratios are used to calculate the remaining network traffic to be routed from the video head-end to each node. The simulation considers the additional traffic due to replacements and is included to find the total traffic to route at each time of the day. Considering replacements on variable cache sizes, the variable cache sizes and cache hit ratios are found from the MILP model for each replacement frequency and are used in the simulation. Traffic demands are routed over the shortest path as we assume network dimensioning where additional network resources are allocated when demanded. However, we do not consider the situation where physical links are limited to maximum capacities, forcing some demands to be routed over longer routes or rejected due to unavailable resources. All other parameters used in the simulation are similar to the input values used in the MILP model. The simulation is run to find the network energy consumption considering SDTV and HDTV when no caches are deployed in the network and when 12 daily content replacements are performed on caches of fixed sizes and caches with sizes varied over the time of the day.

The results show close agreement between the MILP model and the simulation. They also clearly show that content replacements are more beneficial under HDTV, supporting expected future developments in video delivery technologies.

VII. THE INFLUENCE OF REGULAR TRAFFIC ON POWER EFFICIENCY

We have so far considered TV video traffic downloaded from the server to network nodes, but have not included regular traffic. However, some IPTV service providers cater for both video and non-video services including web, email, data, gaming and interactive TV. In this section, we re-evaluate some of the previous scenarios assuming that the

network traffic comprises both regular and TV video traffic. In addition to the formerly evaluated network traffic having only TV video traffic, we consider four further traffic mixtures:

- 10 – 90: Internet traffic reports forecast that by 2016 Internet video traffic will account for about 86% of total Internet traffic [34].

- 30 – 70: This is based on the fact that the 86% share of video in the total traffic is made up of various types of video including TV along with VoD and Peer-to-Peer. Consequently, we consider the situation where regular, VoD and Peer-to-Peer traffic represent 30% of the traffic and the remaining 70% of network traffic is TV video.

- 50 – 50: This traffic mixture represents a service having equal amounts of regular and TV traffic.

- 70 – 30: We consider a scenario where the traffic mixture is that of a service provider whose main service is not TV but still carries some TV video content having 70% regular traffic and 30% TV traffic.

Our intention is to investigate how the presence of regular traffic along with TV traffic influences the power consumption. To implement our evaluation we consider three network schemes that were evaluated in the previous sections: deploying caches of fixed sizes at the network nodes, performing time-based content replacements on the contents of caches of fixed sizes and replacing the contents of caches whose sizes are variable. We run our variable caching and content replacements MILP models after including regular traffic matrices in the input data.

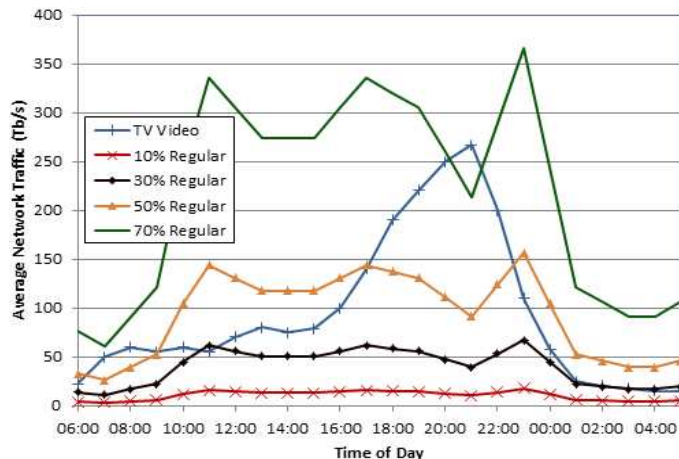

Fig. 14. Average network traffic demand considering TV video traffic and regular traffic where regular traffic is: 10%, 30%, 50% and 70% of the total (regular + TV video) traffic

Under each considered traffic mixture we obtain the total daily regular traffic from the total TV traffic using the traffic ratios that apply to each case. The regular traffic between each node pair is then generated using a random function with mean values compliant with the considered traffic mixtures. The trend and volume of regular traffic under each considered case are shown in Fig. 14. The curves in Fig. 14 show TV video and regular traffic components. Therefore the total traffic mixture of 10 – 90 for example can be calculated by adding the TV video traffic curve to the 10% regular traffic curve. The traffic volume is calculated from the average daily

TV viewing figures in Fig. 3 assuming that all TV programs are streamed using HDTV. Therefore a peak traffic of over 260 Tb/s can be observed which is moderate compared to future busy-hour Internet traffic that is expected to reach 720 Tb/s in 2016 [35].

TABLE III. NETWORK MAXIMUM AND AVERAGE POWER SAVINGS (%) WITH DIFFERENT TRAFFIC MIXTURES UNDER HDTV NSF-SVMP

Traffic Mixtures	Power Savings (%)					
	Fixed Caching		Replacements on Fixed Caches		Replacements on Variable Caches	
	Max.	Avg.	Max.	Avg.	Max.	Avg.
TV Video	31%	30%	47%	31%	83%	74%
10 – 90	30%	27%	36%	26%	78%	66%
30 – 70	26%	21%	32%	20%	68%	50%
50 – 50	21%	14%	26%	14%	54%	34%
70 – 30	15%	8%	18%	8%	38%	21%

In TABLE III and TABLE IV we show the maximum and average savings in power consumption considering TV traffic only and the four assumed traffic mixtures when deploying caches of fixed sizes and when performing content replacements on caches of fixed and variable sizes under NSF-SVMP and BT 21CN-SV4, respectively. Deploying caches in the network reduces the traffic by storing popular TV programs locally. The presence of caches however does not reduce regular traffic passing through the network since the objects related to this traffic type are not stored in caches. Since the MILP models are linear, savings in power consumption are likely to be proportional to the portion of TV traffic in the traffic mixture. As can be inferred from TABLE III and TABLE IV, overall power savings are relative to the TV video component in the network traffic since maximum savings are attained when the traffic is made up of only TV and less power savings are achieved as the percentage of regular traffic increases in the traffic mixture. The linear property of the MILP models allows an estimated calculation of network power savings for any traffic mixture as long as the portion of traffic that will benefit from deployed caches is known.

TABLE IV. NETWORK MAXIMUM AND AVERAGE POWER SAVINGS (%) WITH DIFFERENT TRAFFIC MIXTURES UNDER HDTV BT 21CN-SV4

Traffic Mixtures	Power Savings (%)					
	Fixed Caching		Replacements on Fixed Caches		Replacements on Variable Caches	
	Max.	Avg.	Max.	Avg.	Max.	Avg.
TV Video	36%	34%	48%	34%	86%	77%
10 – 90	36%	33%	44%	32%	84%	73%
30 – 70	28%	25%	35%	24%	74%	59%
50 – 50	25%	19%	30%	18%	64%	45%
70 – 30	19%	12%	23%	12%	44%	21%

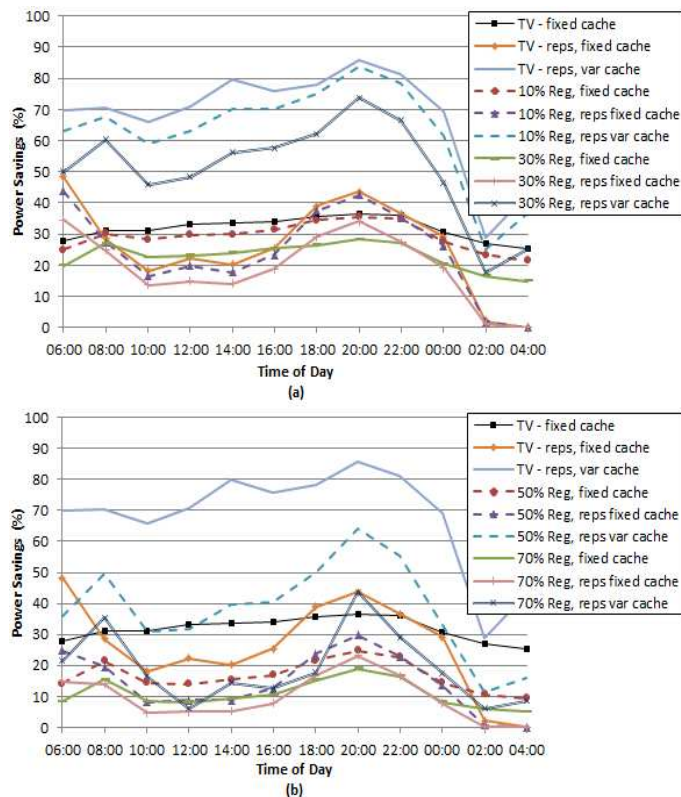

Fig. 15. Power savings (%) over the time of the day with fixed caching and when 12 content replacements are performed on fixed and variable size caches under BT 21CN-SV4 with traffic mixtures of: (a) TV video only, 10 – 90 and 30 – 70 and (b) TV video only, 50 – 50 and 70 – 30

We show, in Fig. 15 (a) and (b), the percentage of power savings over the time of the day when deploying caches of fixed sizes and when performing 12 content replacements on caches of fixed and variable sizes in the BT 21CN-SV4 topology. Fig. 15 (a) shows the power savings with traffic mixtures 10 – 90 and 30 – 70 while Fig. 15 (b) considers the traffic mixtures 50 – 50 and 70 – 30. The peaks of regular traffic and TV traffic are not aligned, see Fig. 14, resulting in a different trend of power consumption over the time of the day under each considered traffic mixture. If caches of fixed sizes are deployed in the network, moderate and comparable power savings are achieved over the time of the day. These savings become more diverse as the amount of regular traffic increases in the traffic mixture. When 12 content replacements are performed on the contents of fixed caches, the amount of power savings vary over the time of the day since popularities of TV programs are different over the time of the day resulting in different cache hit ratios. Nevertheless, the resultant average daily power savings are similar to those assuming fixed caches with no content replacements. The maximum power savings are attained under 12 content replacements with variable caches under all traffic mixtures. The combined influence of varying the size of the cache with respect to traffic and maximizing cache hit ratios due to content replacements results in the greatest power savings compared to other methods. Examining our findings we confirm that our methods are valid under both considered network topologies and produce comparable results.

VIII. CURRENT AND FUTURE NETWORKS

In this section we intend to highlight the significance of our proposed cache management techniques with respect to current and future network technologies.

A. Adaptation

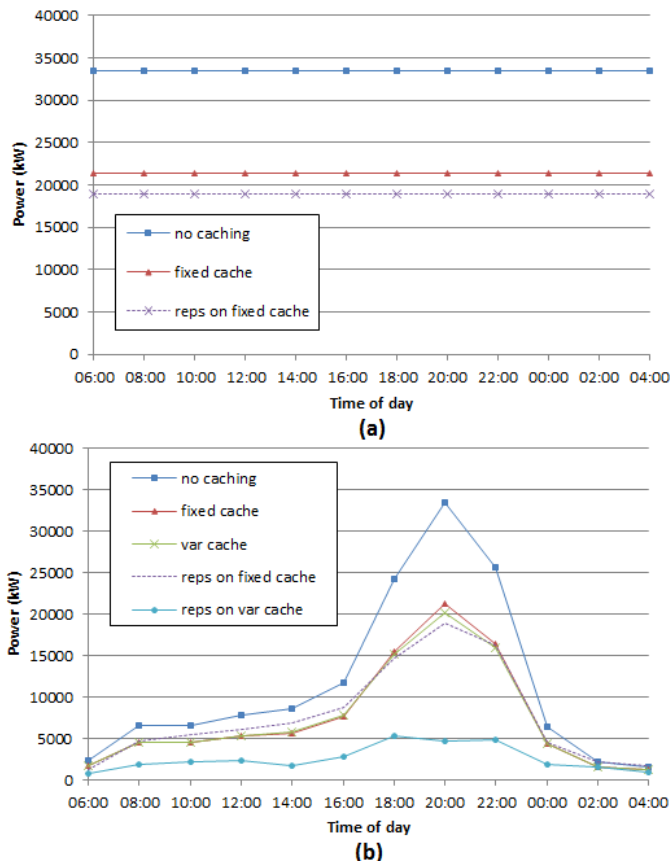

Fig. 16. Power consumption of watching HDTV programs assuming BT 21CN-SV4 considering no caching, caches of fixed sizes, variable cache sizes, content replacements on caches of fixed sizes and content replacements on variable cache sizes assuming the network (a) with no resource adaptation facilities and (b) with resource adaptation facilities

Current networks do not support resource adaptation and networks are provisioned for peak load. As a result, current networks consume constant power, proportional to the peak traffic. Caching significantly reduces peak traffic which could therefore lead to reduction in power consumption. However, greatest benefits will not be obtained until variable sized caches can be deployed.

In Fig. 16 (a) we show the power savings that would be possible with current technology caching HDTV content in the BT 21CN-SV4 topology. The maximum power savings in the network are 36% and 48% for fixed size caches without and with content replacements respectively.

Future networks are expected to be able to adapt their resources by switching off any components that are not in use. This would reduce the power consumption when the traffic is low and therefore the network consumes the maximum power only when the traffic is at its peak. The overall power consumption under this assumption follows the trend of traffic. Our proposed cache management techniques reduce network traffic resulting in lower overall power consumption.

Maximum power savings are achieved when the traffic peaks. Fig. 16 (b) shows the power consumption of our cache management techniques considering a future network with resource adaptation capabilities. The maximum power savings are 36%, 40%, 48% and 86% with caches of fixed sizes, variable cache sizes, content replacement performed on caches of fixed sizes and replacements on variable cache sizes, respectively. The daily-averaged power savings under these schemes are 34%, 36%, 34% and 77%, respectively. As can be observed in Fig. 16, our proposed cache management techniques are suitable for network power consumption reduction considering both current and future network capabilities.

B. Alternative Technologies

Cache management is considered an appropriate method to reduce video traffic generated by the growing number of Internet video services. An alternative technique that can effectively reduce the number of video replications in the network is multicasting. Multicast routing supports the simultaneous delivery of one copy of a video to multiple recipients.

Currently, multicast support is provided at the IP routing layer. In order to minimize energy consumption, we would prefer to implement this functionality within the optical layer. In order for an optical core network to support multicasting, it requires the deployment of Multicast-Capable Optical Cross Connects (MC-OXCs) equipped with light splitters. However, the implementation of WDM multicast in reality is difficult for many reasons:

- The high cost of the MC-OXC construction.
- Multicast algorithms require a large number of wavelengths which cannot be supported by current optical device technology [36].
- Designing optical multicast algorithms is complex as two multicast trees cannot be assigned the same wavelength if they traverse common links [37].

The benefit of multicasting over caching is that no caches are required at the nodes, and therefore no power is consumed for caching. Consequently, multicasting may be more power efficient than cache management if all OXCs in the core network could support multicast routing.

Multicast has a limitation in that viewers have no control (on demand, pause, rewind, etc.) on the video stream. Caching provides an added degree of freedom that allows delay and differentiated viewing times most suitable for emerging TV and video-on-demand services.

IX. CONCLUSIONS

IPTV services are becoming more prominent, contributing to rapidly rising Internet traffic. High quality TV and interactive applications consume substantial amounts of power for storage and transport. In this paper we have investigated the power consumption associated with the delivery of TV programs over an IP over WDM network. We commenced by exploring the dynamics of watching TV including viewing figures and program popularities. We found that the most popular programs attract a significant percentage of total TV

audience. We have therefore proposed using content caches and using the TV schedule to proactively replace the contents of caches a number of times a day to maximize cache hit ratios and power savings. We have evaluated the power consumption of delivering SDTV and HDTV programs with caches of fixed and variable sizes. To achieve that, we considered the time-driven popularity of TV programs, taking into consideration that each program is associated with a large number of requests during a time window while losing its popularity during the rest of the day. Time-based popularities were used to form equations to calculate the resultant cache hit ratios. We developed a MILP model validated by simulation to minimize the power consumption by optimizing the number of daily content replacements. In addition, we extended our model to perform content replacements while varying the sizes of caches at each node at each time of the day. We finally studied the influence of regular traffic on power efficiency by evaluating the power consumption assuming various traffic mixtures containing different shares of TV and regular traffic. We considered the NSFNET and BT 21CN core topologies with both single and multiple video head-ends.

Storing popular TV programs towards the edge of the network achieves an instantaneous power reduction of up to 36% including caching power. When the power consumption of caching is low and fixed caches are deployed, the optimum cache sizes that minimize power consumption are sufficient to store the popular content for the whole day. Therefore, content replacements during the day are not beneficial. However, content replacements significantly save power when user viewing has high variance over time with up to 48% instantaneous power savings in transmission and caching power consumption. These savings are maximized and are up to 86% when variable caches are considered. The significance of caching TV programs rises as demand for IPTV Catch-up services grows and viewing is not real time, and is expected to surpass the power efficiency of IP multicast.

APPENDIX

A. Content Replacement MILP Model Assuming Caches of Fixed Sizes:

Our proposed MILP model minimizes the power consumption of the network by optimizing the number of daily cache content replacements. Some common parts of the MILP model appear in [4] and [5]. However the previous MILP model cannot be easily augmented to reflect content replacements introduced in the current MILP model. Therefore we provide the full MILP formulation. The MILP model defines sets, parameters and variables as follows:

Sets:

- N Set of nodes
- Nm_i Set of neighboring nodes of node i
- T Set of points in time
- R Set of possible daily content replacement frequencies

Parameters:

- Pp Power consumption of a router port

Po_{it} Power consumption of optical switch i at time t

Pt Power consumption of a transponder

Pa Power consumption of an amplifier

Pmd Power consumption of a multiplexer/demultiplexer

B Capacity of a wavelength

W Number of wavelengths in a fiber

Amp_{ij} Amplifiers used on each fiber on the physical link from node i to j

D_{ij} Distance between nodes i and j

S Span distance between two amplifiers

$RPmax_x$ Maximum router ports available to node x

λ^{xyt} Demand from node x to y at time t

δ_i Is 1 if node i has a video server, 0 otherwise, $\sum_{i \in N} \delta_i = u$, where u is the total number of servers in the network

H_{rt} Cache hit ratio at time t when r daily replacements are performed

M_{rt} Cache size in GB at time t when r daily replacements are performed

Φ Cache power consumption factor in W/GB

α_{rt} Is 1 if a replacement is performed at time t with r daily replacements, 0 otherwise

π_{rt} Additional download traffic to be streamed to a node due to a replacement at time t when performing r replacements

Variables:

f_{ij} Fibers on the physical link from node i to j

λ_{ijt}^{xy} Traffic from node i to j , part of the virtual link from node x to y at time t

w_{ijt}^{xy} Wavelengths on the link from node i to j , part of the virtual link from node x to y at time t

w_{ijt} Wavelengths on the physical link from node i to j at time t

C_{xyt} Wavelengths on the virtual link from node x to y at time t

AP_{xt} Aggregation ports at node x at time t

r Number of replacements performed

The power consumption of the network consists of the power consumption of the following components:

1. Router ports at time t , where a port is required for each occupied wavelength:

$$\sum_{i \in N} Pp. \left(AP_{it} + \sum_{j \in Nm_i; i \neq j} w_{ijt} \right)$$

2. Optical switches at time t :

$$\sum_{i \in N} Po_{it}$$

3. Transponders at time t :

$$\sum_{i \in N} \sum_{j \in Nm_i} Pt. w_{ijt}$$

4. Amplifiers at time t :

$$\sum_{i \in N} \sum_{j \in Nm_i} Pa. Amp_{ij}. f_{ij}$$

5. Multiplexers/demultiplexers at time t :

$$\sum_{i \in N} \sum_{j \in Nm_i} Pmd. f_{ij}$$

6. Deployed caches at time t :

$$\sum_{i \in N} \Phi M_{rt}$$

Note that the number of lightpaths from node i to j is allowed to be different to the number of lightpaths in the reverse direction. Thus, f_{ij} and w_{ijt} are not necessarily equal to f_{ji} and w_{jit} , since we have not assumed a simple symmetric case.

The goal of the proposed power-minimized content replacement MILP model is to minimize the network total daily power consumption, and therefore the objective function is defined as:

Objective: minimize

$$\sum_{t \in T} \left(\sum_{i \in N} Pp. \left(AP_{it} + \sum_{j \in Nm_i; i \neq j} w_{ijt} \right) + \sum_{i \in N} Po_{it} + \sum_{i \in N} \sum_{j \in Nm_i} Pt. w_{ijt} + \sum_{i \in N} \sum_{j \in Nm_i} Pa. Amp_{ij}. f_{ij} + \sum_{i \in N} \sum_{j \in Nm_i} Pmd. f_{ij} + \sum_{i \in N} \Phi M_{rt} \right) \quad (7)$$

The model specifies a number of capacity and flow conservation constraints that must be satisfied, as follows:

Subject to:

$$\sum_{x \in N} \sum_{y \in N; x \neq y} w_{ijt}^{xy} \leq W. f_{ij} \quad \forall i \in N, j \in Nm_i, \forall t \in T \quad (8)$$

$$\sum_{x \in N} \sum_{y \in N; x \neq y} w_{ijt}^{xy} = w_{ijt} \quad \forall i \in N, j \in Nm_i, \forall t \in T \quad (9)$$

$$\sum_{x \in N} \sum_{y \in N; x \neq y} \lambda_{ijt}^{xy} \leq w_{ijt}. B \quad \forall i, j \in N, \forall t \in T \quad (10)$$

$$\sum_{y \in N} C_{xyt} + AP_{xt} \leq RPmax_x \quad \forall x \in N, \forall t \in T \quad (11)$$

$$AP_{xt} \geq \sum_{y \in N} (\lambda^{xyt}. \delta_y) / B \quad \forall x \in N, \forall t \in T \quad (12)$$

$$\sum_{j \in Nm_i} w_{ijt}^{xy} - \sum_{j \in Nm_i} w_{jit}^{xy} = \begin{cases} C_{xyt} & i = x \\ -C_{xyt} & i = y \\ 0 & \text{otherwise} \end{cases} \quad \forall i, x, y \in N, \forall t \in T \quad (13)$$

$$\sum_{j \in N; i \neq j} \lambda_{ijt}^{xy} - \sum_{j \in N; i \neq j} \lambda_{jit}^{xy} = \begin{cases} \delta_x. (\lambda^{xyt}. (1 - H_{rt}) + (\alpha_{rt}. \pi_{rt})) & i = x \\ -\delta_x. (\lambda^{xyt}. (1 - H_{rt}) + (\alpha_{rt}. \pi_{rt})) & i = y \\ 0 & \text{otherwise} \end{cases} \quad \forall i, x, y \in N, \forall t \in T, \forall r \in R \quad (14)$$

Objective (7) specifies the power consumption of the network by considering the power consumption of occupied network components at each time of the day. Constraints (8) and (9) are the capacity constraints of the physical layer. Constraint (10) is the physical link capacity constraint. Constraint (11) ensures that the total router ports used at a node do not exceed the maximum ports available to the node. Constraint (12) calculates the required aggregation ports. Constraint (13) is the flow conservation constraint in the optical layer. Constraint (14) is the flow conservation constraint for traffic originating at

nodes equipped with a video head-end. Note that the traffic increases at the times of the day when a replacement is performed, but with the advantage of having higher cache hit ratios throughout the day.

B. Content Replacement MILP Model with Variable Cache Sizes:

This model declares the number of replacements as a parameter in order to evaluate the power consumption of the network under different number of replacements. In addition, having the number of replacements as an input is required to construct the equations of the piecewise linear approximation. Note that the amount of content to be replaced at each replacement is different for each node at each time of the day under each considered number of replacements. We utilize the sets, parameters and variables declared in the original content replacements MILP model previously explained, in addition to the following amendments:

Sets:

K Set of equations that approximate the convex function describing the relationship between the cache size and its hit ratio

Parameters:

r Number of replacements performed

a_{ktr}, b_{ktr} Piece-wise linear approximation equations coefficients, three dimensional vectors

$Trep$ Time duration over which cache contents are updated

Variables:

H_{itr} Cache hit ratio of node i at time t when r daily replacements are performed

M_{itr} Cache size of node i at time t when r daily replacements are performed

π_{itr} Additional download traffic to be streamed to node i at time t when r daily replacements are performed

In order to maintain the linearity of the MILP model, the number of replacements r becomes an input rather than a variable. The power consumption of network components is similar to those in the original model.

The objective of the model is to minimize the total network power consumption over time t , and is given as:

Objective: minimize

$$\sum_{t \in T} \left(\sum_{i \in N} Pp \cdot \left(AP_{it} + \sum_{j \in Nm_i; i \neq j} w_{ijt} \right) + \sum_{i \in N} Po_{it} + \sum_{i \in N} \sum_{j \in Nm_i} Pt \cdot w_{ijt} + \sum_{i \in N} \sum_{j \in Nm_i} Pa \cdot Amp_{ij} \cdot f_{ij} + \sum_{i \in N} \sum_{j \in Nm_i} Pmd \cdot f_{ij} + \sum_{i \in N} \phi M_{itr} \right) \quad (15)$$

Subject to:

The model satisfies constraints (8), (9), (10), (11), (12) and (13) in the original model. Constraint (14) is replaced with:

$$\sum_{j \in N; i \neq j} \lambda_{ijt} - \sum_{j \in N; i \neq j} \lambda_{jit} = \begin{cases} \delta_x \cdot (\lambda^{xyt} \cdot (1 - H_{ytr}) + (\alpha_{rt} \cdot \pi_{ytr})) & i = x \\ -\delta_x \cdot (\lambda^{xyt} \cdot (1 - H_{ytr}) + (\alpha_{rt} \cdot \pi_{ytr})) & i = y \\ 0 & otherwise \end{cases} \quad (16)$$

$$\forall i, x, y \in N, \forall t \in T, \forall r \in R$$

In addition, the model satisfies the following constraints:

$$M_{itr} \geq a_{ktr} \cdot H_{itr} + b_{ktr} \quad (17)$$

$$\forall i \in N, \forall t \in T, \forall r \in R, \forall k \in K$$

$$\pi_{itr} = M_{itr} \cdot 8/Trep \quad (18)$$

$$\forall i \in N, \forall t \in T, \forall r \in R$$

Objective (15) is the power consumption of the network made up of the power consumption of network components at each considered time of the day. Constraint (16) is the flow conservation constraint for downlink traffic. Note that the different cache sizes for each node at each time of the day under each considered number of daily replacements governs the amount of additional download traffic due to a performed replacement. Constraint (17) is the set of convex equations of the piecewise linear approximation utilized to convert a cache hit ratio into its corresponding cache size with respect to the number of daily replacements. Constraint (18) calculates the additional traffic to update cache contents.

REFERENCES

- [1] Global IPTV Forecast 2011-2015, Multimedia Research Group Inc., 2012.
- [2] M. Caria, M. Chamania and A. Jukan, "To Switch On or Off: A Simple Case Study on Energy Efficiency in IP-over-WDM Networks", IEEE 12th International Conference on High Performance Switching and Routing (HPSR), pp 70-76, July 2011.
- [3] W. V. Heddeghem, S. Lambert, B. Lannoo, D. Colle, M. Pickavet, and P. Demeester, "Trends in worldwide ICT electricity consumption from 2007 to 2012", Computer Communications (accepted), 2014.
- [4] N. I. Osman, T. El-Gorashi and J. M. H. Elmoghani, "Reduction of Energy Consumption of Video-on-Demand Services using Cache Size Optimization", Eighth International Conference on Wireless and Optical Communications Networks (WOCN), Paris, France, May 2011.
- [5] N. I. Osman, T. El-Gorashi and J. M. H. Elmoghani, "Caching in Green IP over WDM Networks", Journal of High-Speed Networks (Green Networking and Computing), vol. 19, no. 1, pp. 33-53, 2013.
- [6] B. Sonah and M. B. Ito, "New Adaptive Object Replacement Policy for Video-On-Demand Systems", Sixth International Symposium on Modeling, Analysis and Simulation of Computer and Telecommunication Systems, pp. 13-18, July 1998.
- [7] H. J. Roh, Y. Kim, K. S. Ko and Y. I. Eom, "Design of a Content Replacement Scheme using the p-based LRFU-k algorithm in Contents Delivery Networks", 10th International Conference on Advanced Communication Technology ICACT 2008, vol. 2, pp. 2067 - 2070, February 2008.
- [8] Q. Zhu and Y. Zhou, "Power-Aware Storage Cache Management", IEEE Transactions on Computers, vol. 54, no. 5, pp. 587-602, May 2005.
- [9] S. Podlipnig and L. Boszormenyi, "Replacement Strategies for Quality Based Video Caching", IEEE International Conference on Multimedia and Expo, 2002. ICME '02, vol. 2, pp. 49-52, November 2002.
- [10] H. P. Hung and M. S. Chen, "Maximizing the Profit for Cache Replacement in a Transcoding Proxy" IEEE International Conference on Multimedia and Expo ICME '05, pp. 1162-1165 July 2005.
- [11] Network Management Solution: Optimize Infrastructure for IPTV Services, http://www.cisco.com/en/US/technologies/tk869/tk769/technologies_white_paper0900aecd80730d28.html, date accessed: 2/11/2012
- [12] Feldmann, A. Gladisch, M. Kind, C. Lange, G. Smaragdakis, F. Westphal, "Energy trade-offs among content delivery architectures", 2010 9th Conference on Telecommunications Internet and Media Techno Economics (CTTE), pp. 1-6, 2010.
- [13] S. Dixit, IP Over WDM: Building the Next-Generation Optical Internet, ISBN 0-471-21248-2, John Wiley & Sons, Inc, 2003.

- [14] G. Shen and R. S. Tucker, "Energy-Minimized Design for IP Over WDM Networks", *IEEE/OSA Journal of Optical Communications and Networking*, vol. 1, no. 1, pp. 167 – 186, June 2009.
- [15] X. Dong, T. El-Gorashi and J. M. H. Elmirghani, "Green IP over WDM with Data Centers", *IEEE/OSA Journal of Lightwave Technology*. vol. 29, pp. 1861 – 1880, June 2011.
- [16] X. Dong, T. El-Gorashi and J. M. H. Elmirghani, "On the Energy Efficiency of Physical Topology Design for IP over WDM Networks", *IEEE/OSA Journal of Lightwave Technology*. vol. 30, pp. 1931 – 1942, 2012.
- [17] X. Dong, T. El-Gorashi and J. M. H. Elmirghani, "IP over WDM Networks Employing Renewable Energy Sources", *IEEE/OSA Journal of Lightwave Technology*. vol. 29, pp. 3 – 14, 2011.
- [18] Broadcasters' Audience Research Board (BARB), <http://www.barb.co.uk/viewing/weekly-top-30?>, date accessed: 20/11/2012.
- [19] UK TV Listings, <http://www.onthebox.com/>, date accessed: 09/11/2012.
- [20] BBC iPlayer Performance Pack - November 2012, <http://www.bbc.co.uk/mediacentre/latestnews/2012/iplayer-performance-nov12.html>, date accessed: 24/12/2012.
- [21] Ofcom Communications Market Report 2013, http://stakeholders.ofcom.org.uk/binaries/research/cmr/cmr13/2013_UK_CMR.pdf, data accessed: 27/03/2014.
- [22] TV and Satellite week magazine, 14-20 September 2013.
- [23] Map of All Google Data Center Locations, <http://royal.pingdom.com/2008/04/11/map-of-all-google-data-center-locations/>
- [24] YouTube Architecture, <http://highscalability.com/youtube-architecture>
- [25] Current Thinking on Colossus & 21CN Connectivity, BT Wholesale, https://www.btwholesale.com/pages/downloads/21_Century_Network_Community/c21_NS_21CNColossus_Connectivity_updated.ppt, date accessed 18/03/2013
- [26] BT 21CN - Network Topology & Technology, http://www.kitz.co.uk/adsl/21cn_network.htm, date accessed 18/03/2013
- [27] Cisco ONS 15454 Optical Filter Cards data sheet, http://www.cisco.com/en/US/prod/collateral/optical/ps5724/ps2006/product_data_sheet09186a00801a5572_ps5791_Products_Data_Sheet.html, date accessed 01/02/2013
- [28] Cisco ONS15501 Erbium Doped Fiber Amplifier Data Sheet, http://www.cisco.com/en/US/products/hw/optical/ps2011/products_data_sheet09186a008008870d.html, date accessed 01/02/2013
- [29] Cisco CRS-1 8-Slot Single-Shelf System data sheet, http://www.cisco.com/en/US/prod/collateral/routers/ps5763/ps6112/product_data_sheet0900aecd801d53a1.html, date accessed 01/02/2013
- [30] Glimmerglass Intelligent Optical System 500 Data Sheet, <http://www.glimmerglass.com/products/intelligent-optical-system-500/>, data accessed 14/03/2014.
- [31] V. Valancius, N. Laoutaris, L. Massoulie, C. Diot, and P. Rodriguez, "Greening the internet with nano data centers," in *Proc. CoNEXT*, 2009, pp. 37–48.
- [32] J. Elerath and M. Pecht, "A Highly Accurate Method for Assessing Reliability of Redundant Arrays of Inexpensive Disks (RAID)", *IEEE Transactions on Computers*, vol. 58, no. 3, March 2009.
- [33] Triple-play Services Quality of Experience (QoE) Requirements, The Digital Subscriber Line Forum, <http://www.broadband-forum.org/technical/download/TR-126.pdf>, date accessed 01/02/2013
- [34] Cisco Visual Networking Index: Forecast and Methodology, 2011-2016, Cisco White Papers, http://www.cisco.com/en/US/solutions/collateral/ns341/ns525/ns537/ns705/ns827/white_paper_c11-481360_ns827_Networking_Solutions_White_Paper.html, date accessed 19/04/2013
- [35] Cisco Visual Networking Index: The Zettabyte Era, Cisco White Papers, http://www.cisco.com/en/US/solutions/collateral/ns341/ns525/ns537/ns705/ns827/VNI_Hyperconnectivity_WP.html, date accessed 08/05/2013
- [36] D. Danh Le, M. Molnar and J. Palaysi, "An Improved Multicast Routing Algorithm in Sparse Splitting WDM Networks", 2013 International Conference on Computing, Management and Telecommunications (ComManTel), pp. 99-104, January, 2013.
- [37] N. Singhal, L. Sahasrabudde and B. Mukherjee, "Optimal Multicasting of Multiple Light-Trees of Different Bandwidth Granularities in a WDM Mesh Network with Sparse Splitting Capabilities", *IEEE/ACM Transactions on Networking*, vol. 14, no. 5, pp. 1104-1117, October 2006.
- Niemah I. Osman** received the B.Sc. degree (first-class Honours) in Computer Science from Sudan University of Science and Technology, Khartoum, Sudan, in 2002 and the M.Sc. degree (with Distinction) in Mobile Computing from the University of Bradford, Bradford, U.K., in 2006. She is currently pursuing her PhD in Energy Efficient Content Delivery Networks at the University of Leeds, Leeds, U.K.
- She has been a Lecturer at the faculty of Computer Science and Information Technology, Sudan University of Science and Technology, Sudan and was the Head of Department of Computer Science and member of the university senate in 07/2008. Her recent areas of interest include: content distribution networks and energy aware communication networks.
- Taisir El-Gorashi** received the B.S. degree in electrical and electronic engineering from the University of Khartoum, Sudan, in 2004, the M.Sc. degree in photonic and communication systems from the University of Wales, Swansea, U.K., in 2005, and the Ph.D. degree in optical networking from University of Leeds, U.K., in 2010. She is currently a Postdoctoral Research Fellow in the School of Electronic and Electrical Engineering, University of Leeds. Her research interests include next-generation optical network architectures and green Information and Communication Technology.
- Louise Krug** received a BSc degree in Physics from Manchester University and an MSc in Computing Science from the University of Essex. She is a Senior Researcher in BT specializing in energy and carbon reduction of telecommunications networks. Previous research projects have included 2D-integrated optics, quality of service for wireless networks and software agents for mobility services.
- Jaafar Elmirghani** received a BSc (Hons) First Class in Electrical Engineering from the University of Khartoum, Sudan in 1989 and the PhD in 1994 from the University of Huddersfield, UK for work on optical receiver design and synchronization. He is a Fellow of the IET, Fellow of the Institute of Physics, Senior Member of IEEE and is the Director of the Institute of Integrated Information Systems and Professor of Communication Networks and Systems within the School of Electronic and Electrical Engineering, University of Leeds, UK. He joined Leeds in 2007 and prior to that (2000–2007) as chair in optical communications at the University of Wales Swansea he founded, developed and directed the Institute of Advanced Telecommunications. He was Chairman of the IEEE UK and RI Communications Chapter and was Chairman of IEEE ComSoc Transmission Access and Optical Systems Committee and Chairman of IEEE ComSoc Signal Processing and Communication Electronics (SPCE) Committee. He was a member of IEEE ComSoc Technical Activities Council' (TAC), was an editor of IEEE Communications Magazine and is and has been on the technical program committee of 29 IEEE ICC/GLOBECOM conferences between 1995 and 2012 including ten times as Symposium Chair. He was founding Chair of the Advanced Signal Processing for Communication Symposium which started at IEEE GLOBECOM'99 and has continued since at every ICC and GLOBECOM. Prof. Elmirghani was also founding Chair of the first IEEE ICC/GLOBECOM optical symposium at GLOBECOM'00, the Future Photonic Network Technologies, Architectures and Protocols Symposium. He chaired this Symposium, which continues to date. He received the IEEE Communications Society 2005 Hal Sobol award for exemplary service to meetings and conferences, the IEEE Communications Society 2005 Chapter Achievement award, the University of Wales Swansea inaugural 'Outstanding Research Achievement Award', 2006, the IEEE Communications Society Signal Processing and Communication Electronics outstanding service award, 2009, and all four prizes awarded by the University of Khartoum for academic distinction in the Electrical Engineering Department. Prof. Elmirghani is currently an editor of IET Optoelectronics, editor of Journal of Optical Communications, Co-Chair of the GreenTouch Core Switching and Routing Working Group, an adviser to the Commonwealth Scholarship Commission, member of the Royal Society International Joint Projects Panel and member of the Engineering and Physical Sciences Research Council (EPSRC) College. He has been awarded in excess of £20 million in grants to date from EPSRC, the EU and industry and has held prestigious fellowships funded by the Royal Society and by BT. He has published over 350 technical papers, co-edited "Photonic Switching Technology- Systems and Networks", IEEE Press 1998, leads a number of research projects and has research interests in communication networks, and optical communication systems.