

*promoting access to White Rose research papers*



**Universities of Leeds, Sheffield and York**  
**<http://eprints.whiterose.ac.uk/>**

---

This is an author produced version of a paper published in **Lighting Research and Technology**.

White Rose Research Online URL for this paper:  
<http://eprints.whiterose.ac.uk/76654>

---

**Published paper**

Fotios, S.A. and Cheal, C. (2011) *Predicting lamp spectrum effects at mesopic levels. Part 2: Preferred appearance and visual acuity*. *Lighting Research and Technology*, 43 (2). 159 - 172. ISSN 1477-1535  
<http://dx.doi.org/10.1177/1477153510393933>

---

# **Predicting Lamp Spectrum Effects at Mesopic Levels**

## **Part 2: Preferred Appearance and Visual Acuity**

Steve Fotios, PhD, and Chris Cheal, PhD  
University of Sheffield, School of Architecture

*Fotios SA & Cheal C, Predicting Lamp Spectrum Effects At Mesopic Levels. Part 2: Preferred Appearance and Visual Acuity, Lighting Research & Technology, 2011; 43(2); 159-172.*

### **Abstract**

Laboratory tests were carried out to investigate lighting for pedestrians at mesopic levels under lamps of different spectral power distribution. This article reports on evaluation of lamp spectrum effects on visual acuity, using Landolt ring charts of high and low luminance contrasts, and forced choice judgements of the preferred appearance of human hands, a colour array, and an illuminated space. These were carried out alongside judgements of brightness reported in a previous article. Five types of lamp were used, including standard high pressure sodium, three metal halide and fluorescent lamps of broader spectral distribution, and a two-colour LED. It was found that lamp spectrum affected judgements of preferred appearance, with the HPS and LED lamps being considered poor compared with the two metal halide lamps; these results correlated better with the CIE general colour rendering index than other metrics of lamp spectral characteristics. It was also found that acuity was affected by lamp SPD, with the HPS lamp enabling more Landolt rings to be correctly read than lamps of higher S/P ratio.

## 1. Introduction

This article discusses lamp spectral power distribution (SPD) and lighting for pedestrians in residential streets. In the UK, where lighting in subsidiary streets is designed for the demands of the pedestrian, the design illuminance is specified through two documents. BS EN 13201-2:2003<sup>1</sup> specifies the minimum maintained average horizontal photopic illuminance for six lighting classes, the S-series, ranging from S6 = 2.0 lux to S1 = 15.0 lux. BS5489-1:2003<sup>2</sup> is a code of practice and this suggests a strategy for the selection of a lighting class according to crime rate, environmental zone and traffic flow.

Furthermore, BS5489-1:2003 suggests a reduction of one S class (i.e. a reduced illuminance) if lamps of General Colour Rendering Index (CRI)  $R_a \geq 60$  are used. It is recognised that colour rendering index may not be an appropriate metric for defining the impact of lamp spectrum on visual tasks other than the naturalness of colours, and furthermore that the threshold value of 60 is arbitrary. The current work was carried out towards improving the characterisation of lamp SPD and illuminance for visual tasks pertinent to pedestrians at night time.

In residential areas there is a need for areas to appear brightly lit as people link spatial brightness with safety. Lighting makes an important contribution to making a place feel safe<sup>3</sup> and the higher the perception of brightness, the greater the feeling of safety.<sup>4</sup> The first part of this report<sup>5</sup> investigated lamp SPD and illuminances for equal brightness at mesopic levels and found higher correlation with the ratio of Scotopic to Photopic luminances (S/P ratio) of the light source than with other lamp characteristics such as CRI, correlated colour temperature (CCT), and gamut area index (GAI).<sup>6</sup> The new CIE recommended system for visual performance based mesopic photometry<sup>7</sup> which uses the S/P ratio as an input variable, was also found to correlate well with illuminance ratios for equal brightness and thus provides a recognised system for predicting the relationship between lamp type and illuminance for a given level of brightness. However, it would be a mistake to recommend lighting based on brightness effects without consideration as to whether that lighting would be acceptable to users and how the lighting affected the ability to perform visual tasks. Hence alongside brightness matching trials<sup>5</sup> preference judgements (of skin appearance, colours, and the lit space) were carried out to give a measure of acceptability and on-axis visual acuity was measured using a Landolt ring task.

A review<sup>8</sup> of previous studies of visual acuity at mesopic levels concluded that there is little evidence that SPD can affect foveal visual acuity of achromatic targets in mesopic conditions and this was subsequently confirmed using a Landolt ring test.<sup>9</sup> At photopic levels there is disagreement about the extent to which changes in visual acuity caused by differences in SPD matter to the performance of visual tasks in realistic conditions,<sup>10,11</sup> a possible explanation being that the effect of SPD is important only when the task is reduced to threshold conditions, these being below normal experience. To exaggerate any difference between different types of light source visual acuity was further examined using an achromatic Landolt ring task of low luminance contrast; the contribution of luminance contrast to identification would thus be reduced, enabling a contribution to acuity from the parvocellular pathways to become more prominent.

The SPD of a light source affects the colour rendition of illuminated surfaces, thus if the appearance of a surface changes under different lamps it is possible that its appearance will be preferred under some types of lamp more than others. Schanda<sup>12</sup> suggested that colour appearance of the human complexion may be a key consideration in determining the acceptance of a light source and Kanaya et al<sup>13</sup> suggested that the appearance of human skin is the tool used in real situations by naïve observers to determine the acceptability of an illumination. There is some evidence that lamp SPD effects the appearance of skin at photopic levels: Quellman & Boyce<sup>14</sup> examined preferred appearance of a range of skin tones under different types of lamp and found significant differences between the skin types as to their preference for lamp type. While it may be expected that the preferred appearance of coloured surfaces would change with lamp type, no evidence pertinent to mesopic light levels was located. What is known is that lamp type affects the ability to name colours at mesopic levels, with lamps of higher colour rendering index enabling a higher colour naming accuracy than lamps of lower colour rendering index, and this difference diminishes as the luminance decreases toward the scotopic state.<sup>9,15,16</sup> Thus judgements of preferred appearance of hands and colours were carried out under different light sources to give an indication of the acceptability of different light sources.

## **2. Method**

Preferred appearance and visual acuity tests were carried out under different light sources using the side-by-side booths shown in Figure 1. Five different lamps were used

in these trials, as identified in Table 1 and Figure 2. These were two types of metal halide lamp (MH2, CPO), a compact fluorescent (CFL2), a standard high pressure sodium (HPS) lamp and a solid state device (LED). This LED source was not the usual white LED consisting of a blue LED with a phosphor but rather a two colour LED. The preference judgements employed side-by-side (simultaneous) evaluations and for these the five lamps were observed in all ten possible paired comparisons. A sixth type of lamp (CFL: 3729K,  $R_a$  79) was used for null condition trials, forming an eleventh lamp pair.

The viewing chamber of each booth was of approximate dimensions 575mm deep x 680mm wide x 660mm high. The interior surfaces were painted matt grey (Munsell N5) and contained coloured objects, these being four pyramids 60mm high, one each made from red, green, yellow and blue card. The test lamps were fitted behind the booths. Light was conveyed into the top of the booth through an internally reflective pipe of diameter 190mm. The illuminance in a booth was adjusted by a rotary control connected to an iris in the pipe, enabling the illuminance to be varied without affecting the spectral power distribution or spatial distribution of light. A translucent diffuser was placed above the visible chamber of the booths to further reduce differences in spatial distribution of light between stimuli. Surface luminances were measured at 14 points in each booth to assess the stability of the relative luminance distribution between different combinations lamp and between the two booths. No significant differences were found between the left-hand and right-hand booths, or between changes in light sources. A reference illuminance of 5.0 lux was used for these trials, measured at the centre of the floor of the booths. The mean luminance of the 14 points at 5.0 lux was approximately  $0.25 \text{ cd/m}^2$ .

Luminances were measured using a Konica Minolta LS100 luminance meter and illuminances were measured using Konica Minolta T-10 illuminance meters, one per booth. These meters have a spectral sensitivity that closely matches the standard photopic observer, giving an accuracy within  $\pm 2\%$ , and all meters were calibrated by Konica-Minolta immediately prior to these tests. The spectral correction factor for HPS lamps and those of broader distribution with this standard of photometer is less than 1%.<sup>17,18</sup>

Preference was judged by appraisal of three items:

- Preferred appearance of hands: following the approach used by Quellman and Boyce<sup>14</sup> the test participant stood immediately in front of the booths and placed one hand into each booth so that the appearance of human skin could be judged.
- Preferred appearance of colours: a Macbeth 24 square colour rendition chart was placed flat on the floor of each booth, at the front edge, on each side of the central partition. This was again judged when stood immediately in front of the booths.
- Preferred appearance of the lit space: to gain a judgement of the appearance of an illuminated space rather than of specific objects, the booths were observed without the presence of hands or the colour chart. This judgement was made when seated 1.0m in front of the booths.

Test participants were asked in which booth they preferred the appearance of the target object, a forced choice task. Preference judgements recorded when lighting from both lamps in a pair were set to equal illuminance provided a comparison which controls all variables other than lamp type. However, an application of these data is lighting that is matched for equal brightness not equal illuminance, and lighting from two lamps matched for equal brightness may be of unequal illuminance.<sup>5</sup> Therefore these preference judgements were recorded on two occasions, firstly at equal illuminance, with both booths set to the reference illuminance (5.0 lux) and secondly at equal brightness, this being the final one of the four brightness matches set by the test participants. The location of lamps to the left-hand and right-hand booths was counterbalanced between subjects.

On-axis visual performance was examined using low and high contrast Landolt-ring acuity charts, and in trials these charts were located on the vertical rear wall of one of the booths. The Landolt rings were printed on grey A4 paper (Daler Rowney Canford, dreadnought grey matt paper, 150 gsm) having a reflectance of approximately  $r=0.20$ . An acuity chart had 12 rows each of five equally sized Landolt rings and multiple versions of the chart with varying gap directions were used. The spacing between Landolt rings in each row was equal to half diameter of a Landolt ring on that row, while between-row spacing was equal to twice the diameter of the Landolt rings on the smaller (lower) row: a constant relationship between target size and row spacing was also used for the Bailey-Lovie visual acuity chart.<sup>19</sup> With the current charts viewed from a distance of 1615mm the visual angle subtended by the Landolt ring gap decreased from 8.5 min.

arc on the top row to 0.7 min. arc on the bottom row, using 0.1 log unit steps as on the Bailey-Lovie chart.<sup>19</sup>

Luminance contrasts of the Landolt rings to their background were  $C=0.22$  for the low contrast chart and  $C=0.87$  for the high contrast chart, as measured under a Verivide D65 daylight simulating fluorescent lamp. These ranges of target size and target contrast were determined using acuity and contrast threshold results from previous work<sup>9</sup> and were expected to allow all participants to read the largest chart row with 100% accuracy while no one could read the smallest row. The two levels of contrast are also similar to those used by Vrabell et al.<sup>20</sup> Viewing distance to the centre of the chart was approximately 1615mm. In order that the threshold performance level was reached, following previous work,<sup>10</sup> participants were instructed to provide a 'best guess' when they could not see the Landolt ring orientation. The acuity task ended only when the next (i.e. smaller) row could not be seen to consist of individual symbols.

Luminance of the test chart was measured at five locations, the centres of the top row and bottom row and at three points equally spaced in between these. The range of luminances down the chart for the MH2 lamp, for example, were  $0.258 \text{ cd/m}^2$  at the top line to  $0.224 \text{ cd/m}^2$  at the bottom line.

Tests with each participant were completed in three two-hour sessions. The room lighting for the initial ten minutes of a test session was from a fluorescent (warm white) table lamp which indirectly lit the room and from the first lamp pair in the side-by-side booths; all surfaces visible to the test participant had luminances below  $3 \text{ cd/m}^2$ . In this time the participant was given instructions for the test procedure. The table lamp was then switched off for a further ten minutes of adaptation. For a given lamp pair the test procedure was:

- (1) Preference judgements and brightness discrimination at equal illuminances (5.0 lux);
- (2) Brightness matching. Each test participant provided four brightness matches for each lamp pair, counterbalancing both the initial illuminance of the variable stimulus (set by the experimenter to an illuminance clearly higher or lower than the reference) and application of dimming to both sources, and these four trials were attempted in a random order;

- (3) With the illuminance setting of the test participant's final brightness match, the three preference judgements were repeated at this setting of equal brightness, and;
- (4) Visual acuity was examined using the low-contrast and high-contrast charts presented in one booth set to an illuminance of 5.0 lux. The iris in the light pipe connected to the other booth was fully closed. Presentation order of the high and low contrast charts was counterbalanced.

The same procedure was used for all ten lamp pairs and the null condition pair (except that the acuity test was not carried out with the null condition lamps), and these lamp pairs were presented in an order that was balanced between participants. The lamp housing behind each booth accommodated only a single type of lamp, these being fixed to trays, and the experimenter slid alternate lamp trays into position between trials. The lamp trays were assembled so that when slotted into the housing the centre of the light source was aligned with the centre of the light pipe. For the HPS, CFL2, MH2 and CPO lamps a warm-up period of five minutes was allowed, this having previously been found sufficient to enable the SPD to stabilise. The LED lamp however required much longer to stabilise, approximately 90 minutes, and thus this lamp was switched on prior to a test session and kept in an adjoining room until it was needed.

Thirty eight test participants were used, this number chosen to meet the demands of the variance stable rank sums (VSRS) method for analysing data from the preference judgements.<sup>21</sup> All subjects were confirmed as having colour-normal vision using the Ishihara test. Fourteen test participants were male and 24 were female; 21 were young (aged 18-34), 14 were in the 35-54 age group, and three were older than 55 years.

### **3. Results and Analysis**

#### **3.1 Null condition preference results**

The preference task was carried out with the same type of lamp (CFL) in both booths. Table 2 shows the null condition results, formatted to analyse for differences between the left-hand and right-hand booths and between the two supposed identical lamps used in null condition trials which were nominally labelled CFL<sub>A</sub> and CFL<sub>B</sub>. There were 38 trials, and in the absence of bias the preference judgements would tend towards 19 (i.e. 50%) in each case. Differences were examined using the Binomial test.



Table 2 indicates there was a slight tendency to prefer lighting from CFL<sub>A</sub> rather than CFL<sub>B</sub> but the Binomial test does not suggest these differences to be significant. The mean number of votes for CFL<sub>A</sub> across all six cases is 21.8. For three cases there was a tendency to prefer the left-hand booth and in three cases the right-hand booth; the mean preference score for the left-hand booth was 19.5. Again the Binomial test does not suggest these differences to be significant.

Null condition data from the preference trials do not suggest a difference between the two booths. The results of the brightness matching and brightness discrimination null condition tests also suggest that any differences between the booths other than lamp type were negligible.<sup>5</sup>

### **3.2 Preferred appearance results**

The preference results are shown in Table 3. These data are the percentage of judgements by which the target object under one of each pair of lamps was preferred when presented at equal illuminance and at equal brightness. The MH2 and CPO lamps appear to be the most preferred and the HPS and LED the least preferred. Table 4 shows the total preference votes awarded to each lamp across all paired comparisons in rank order of preference for each target item. The rank order of lamps is not same for every item but there is an apparent trend. The two lamps with the lowest preference scores tend to be the HPS and LED lamps, except for the appearance of hands where CFL2 has a low score. MH2 and CPO have the highest preference scores in all six items except for the appearance of the space at equal illuminance where CFL2 has a higher score than CPO but this is only by one point.

Differences between the lamps were analysed using VSRS.<sup>21</sup> The trial was designed with the express intent of analysing the results using VSRS because it was previously applied to discrimination data in the Quellman and Boyce<sup>14</sup> study of preferred skin appearance and because the type of data matches that described for use with VSRS.<sup>21</sup> Figure 3 shows the lamps which the VSRS test does not find the preference scores to be significantly different (i.e.  $p > 0.05$ )

The pattern apparent in Figure 3 supports the observations drawn from Tables 3 and 4, that the HPS and LED lamps tended to offer the least preferred appearance of hands, colour array and space, and the MH2 lamp and CPO lamps tended to offer the most preferred appearance of these items. This order is supported by the results from all three observation targets; hands, the colour array, and the whole space.

Judgements of hand appearance provide the least ambiguity, their being a clear distinction between two groups of lamps, with the HPS, LED and CFL2 providing least preferred hand appearance and the CPO and MH2 providing most preferred hand appearance. For preferred appearance of colours and the whole space Figure 3 demonstrates some overlap; in judgements of the space at equal illuminance, for example, the HPS and LED are equally preferred and the LED, CFL2 and CPO are equally preferred, but the CFL2 and CPO have significantly higher preference than the HPS.

Figure 3 shows that preference judgements made at equal illuminance and equal brightness are reasonably similar. Differences may be explained by differences in illuminance at equal brightness. Consider for example, judgements of the space: at equal illuminance the HPS lamp has a lower preference than the CFL2, but at equal brightness, where the HPS illuminance tended to be higher than the CFL2 illuminance<sup>5</sup> the difference in their preference scores was not suggested to be different.

The results of the preference tests suggest that lighting from the MH2 and CPO lamps would be the most acceptable, while lighting from the HPS and LED would be the least acceptable. The rank order of brightness of these lamps was suggested to be (in descending order of brightness) LED, CFL2, MH2, CPO, HPS,<sup>5</sup> so the LED lamp, considered to be the brightest, was one of the least acceptable.

### **3.3 Predicting preferred appearance**

To explore metrics for predicting preferred appearance the test results were plotted against a range of metrics for characterising lamp SPD, i.e. CRI, CCT, GAI and the S/P ratio, and also the CIE system for mesopic photometry.<sup>7</sup> The coefficient of determination ( $R^2$ ) of linear regression between the plotted variables was used as a measure of the amount of variability in preference that is explained by each metric.<sup>22</sup> A higher  $R^2$

suggests a better prediction of preference, although it cannot be used to infer a causal relationship.

This was done initially for ratios of preference scores for each of the ten lamp pairs and ratios of the prediction metrics. This approach follows that used for the brightness data<sup>5</sup> and, because it employs ten data points (the ten lamp pairs) rather than the five individual lamps, it improves confidence of the regression relationship. Table 5 shows the  $R^2$  values. It is clear that the best prediction of preference is found with the CIE general colour rendering index, followed by gamut area index (GAI). The S/P ratio, CCT, and CIE mesopic photometry give poor predictions of preference. Figure 4 shows linear regression for the results of the preferred appearance of hands at equal illuminance and equal brightness against ratios of CRI and the S/P ratio

This analysis was repeated using absolute values of preference scores and prediction metrics. This was done by taking the mean preference score for each lamp averaged across the three rated items (hands, colours and space) for equal brightness and equal illuminance separately and for the two combined. There was negligible difference between these approaches to analysing the data. It was again found that CRI gave the best prediction of preference ( $R^2 > 0.85$ ), followed by GAI ( $R^2 = 0.5$  to  $0.6$ ), and CCT and the S/P ratio both gave poor predictions ( $R^2 < 0.03$ ). Figure 5 shows preference scores for the five lamps, these being the mean of judgements for the three items at equal illuminance and equal brightness, plotted against CRI ( $R^2 = 0.91$ ).

This analysis suggests that CRI gives a prediction of the preferred appearance of hands, a colour array, and a lit space, at mesopic levels under lighting of different SPD that is more precise than does the S/P ratio, CCT, CRI, gamut area and the CIE mesopic system for mesopic photometry. However it is evident from these results that CRI is not perfect; note for example that while CPO has a higher preference than CFL2 for hand appearance they have almost the same CRI. These metrics were examined following consideration for predicting brightness<sup>5</sup> and practical lighting guidance requires as few as possible metrics. Alternative metrics for characterising colour rendering properties are being evaluated in CIE Technical Committee 1-69, and the proposals from this committee will be used to re-examine the current data.

### 3.4 Acuity results

Figure 6 shows the results of the acuity tests. Following previous work<sup>15</sup> the acuity test was analysed by counting number of Landolt ring gap directions correctly identified in each test condition. Analysis of the data did not suggest they were drawn from a normally distributed population. Hence the primary statistical analyses of difference were carried out using non-parametric tests, the Wilcoxon signed ranks test for comparing two conditions and Friedman's test for three or more conditions.<sup>23</sup> Parametric tests are better at detecting differences than non-parametric tests<sup>23</sup> and therefore the conclusions drawn were subsequently reviewed using parametric tests, the *t*-test and ANOVA for two conditions and three or more conditions respectively. The *t*-test is suggested to be robust against non-normal populations for larger samples even though the data may be non-normal to a noticeable degree.<sup>24</sup> The current sample size of  $n=38$  is only just below the threshold of  $n \geq 40$  for which it is suggested the *t*-test can be applied to all distributions.<sup>25</sup>

Each test participant carried out the low contrast and high contrast tasks under each type of lamp on two separate occasions. Comparison of results gained on the 1<sup>st</sup> and 2<sup>nd</sup> trials suggests a slight learning effect: the mean ratios of scores (2<sup>nd</sup> / 1<sup>st</sup>) for the ten test conditions (5 lamps x 2 target contrasts) were greater than 1.0 in eight conditions, with a maximum ratio of 1.05 and a minimum of 0.98. Wilcoxon's test does not suggest differences between the first and second trials to be significant for any of the ten test conditions, and the results shown in Figure 6 are the summation of Landolt rings correctly read in both trials.

Figure 6 suggests that the HPS lamp allowed the greatest number of Landolt rings to be correctly read and the LED the least. Analysis of the results (number of Landolt rings correctly read) using Friedman suggested a significant effect of lamp type ( $p < 0.001$ ) for both low contrast and high contrast tasks. Analysis using ANOVA suggested that there were significant differences between lamp type ( $p < 0.001$ ) and between the two levels of contrast ( $p < 0.001$ ) but there was no indication of a significant interaction between lamp type and contrast ( $p = 0.761$ ).

Differences between each lamp pair in the number of correctly read Landolt rings were examined using the Wilcoxon test. Conclusions drawn for the low contrast chart were the

same as for the high contrast chart except for the case of the CPO-CFL2 lamp pair, where results from the high contrast chart suggest a difference between the lamps ( $p < 0.05$ ) but results from the low contrast chart do not ( $p > 0.3$ ). Analysis of differences between lamps was made by consideration of the overall pattern of results and also by setting a threshold value of  $p < 0.005$  to counter capitalising on chance, i.e. the Bonferroni correction to the standard threshold  $p < 0.05$  for ten cases.

When interpreted alongside Figure 6 statistical analyses suggest that the LED lamp enabled a lower number of Landolt rings to be correctly identified than did any of the other four lamps (CFL,  $p < 0.005$ ; HPS, CPO, MH2,  $p < 0.001$ ). The HPS enabled more Landolt rings to be correctly identified than did the MH2 lamp ( $p < 0.005$ ) and the CFL2 lamp for the high contrast task ( $p < 0.001$ ), but there was no significant difference between the HPS lamp and the CPO lamp or the CFL2 lamp at low task contrast. Differences between the CPO, MH2 and CFL2 lamps were not suggested to be significant.<sup>†</sup> The differences though are small: the greatest difference is that HPS lighting allowed approximately five more Landolt rings to be read than did LED lighting.

Figure 6 suggests that the number of Landolt rings correctly read was greater at the higher contrast than at the lower contrast. For each of the five lamps, the effect of contrast was suggested to be significant ( $p < 0.001$ , Wilcoxon and  $t$ -test). The rank order of lamps did not change with the change in contrast.

In previous work it was found that lamp SPD did not affect visual acuity.<sup>9</sup> A difference between these two studies is that in the current work test participants were given stronger encouragement to attempt difficult-to-read rows, following the comments from Berman et al.<sup>10</sup> This was done by instructing the test participant to attempt to identify gap directions if they could detect the next (i.e. smaller) complete row of Landolt rings.

These results suggest an inverse relationship with the S/P ratio, with lighting of lower S/P ratio leading to an increase in Landolt rings correctly read. In addition to disagreement with previous studies at mesopic levels which suggest no effect of SPD on

---

<sup>†</sup> If the threshold value for a significant difference is retained at  $p < 0.05$  there are two differences in conclusions of visual acuity drawn from this analysis: the CPO-CFL2 are different at high contrast, and the HPS-CFL2 are different at low contrast.

visual acuity<sup>8,9</sup> this trend is in opposition to those studies at photopic levels which report a significant effect of SPD on acuity,<sup>10,26</sup> with lamps of higher S/P ratio leading to an improvement in acuity and this is apparently due to smaller pupil sizes. The inverse relationship between S/P ratio and visual acuity found in the current work is therefore unexpected. Differences in the luminance contrast of the Landolt rings against the background under different light sources were negligible and therefore unable to explain differences in acuity. Further work is being planned to determine if this result is coincidental or is a salient visual phenomenon.

#### **4. Conclusion**

These tests suggest that lamp SPD affects the preferred appearance of objects and visual acuity at mesopic light levels. The appearance of human hands, a colour array, and a lit space tended to be preferred more when using lighting of higher CRI, and this was found in judgements made with lamps matched for equal illuminance and for equal brightness. There was a slight increase in the ability to read foveal achromatic Landolt rings with HPS lighting compared with the other lamps used, while the LED lighting gave the poorest ability to read the Landolt rings, an inverse relationship with the S/P ratio. It appears that the effect of SPD on acuity was gained by forcing test subjects to attempt targets at threshold levels, so further data are needed to determine the significance of this for tasks of supra-threshold acuity.

#### **References**

- 1 British Standards Institution (BSI) BS EN 13201-2:2003, Road lighting - Part 2: Performance requirements, London: BSI, 2003
- 2 British Standards Institution (BSI) BS5489-1:2003, Code of practice for the design of road lighting —Part 1: Lighting of roads and public amenity areas, London: BSI, 2003
- 3 Loewen LJ Steel GD & Suedfeld P. Perceived safety from crime in the urban environment, *Journal of Environmental Psychology*, 1993; 13; 323-33
- 4 Boyce PR, Eklund NH, Hamilton BJ & Bruno LD, Perceptions of safety at night in different lighting conditions, *Lighting Research & Technology*, 2000; 32; 79-91
- 5 Fotios S and Cheal C, Predicting Lamp Spectrum Effects At Mesopic Levels, Part 1: Brightness. *Lighting Research & Technology*. In press.

- 6 Rea MS and Freyssinier-Nova JP. Color rendering: A tale of two metrics. *Color Research and Application* 2008; 33(3); 192-202
- 7 Commission Internationale de L'Éclairage, *Recommended system for visual performance based mesopic photometry*, CIE publication 191, Vienna: CIE, 2010
- 8 Fotios SA, Cheal C and Boyce PR, Light Source Spectrum, Brightness Perception and Visual Performance in Pedestrian Environments: A Review, *Lighting Research & Technology*, 2005; 37(4); 271-294
- 9 Fotios SA & Cheal C, Lighting for subsidiary streets: investigation of lamps of different SPD. Part 1 – Visual Performance, *Lighting Research & Technology*, 2007; 39(3); 215-232
- 10 Berman SM, Navvab M, Martin MJ, Sheedy J and Tithof W, A comparison of traditional and high colour temperature lighting on the near acuity of elementary school children, *Lighting Research & Technology*, 2006; 38(1); 41-52
- 11 Boyce PR, Akashi Y, Hunter CM & Bullough JD, The impact of spectral power distribution on the performance of an achromatic visual task, *Lighting Research & Technology*; 2003; 35(2): 141-161
- 12 Schanda J, A combined colour preference-colour rendering index, *Lighting Research & Technology*, 1985; 17(1); 31-34
- 13 Kanaya S, Hashimoto K, and Kichize E. Subjective balance between general color rendering index, color temperature, and illuminance of interior lighting. Proc. CIE 19th Session (Kyoto), 1979, 274-278.
- 14 Quellman EM, Boyce PR. The light source color preferences of people of different skin tones. *Journal of the Illuminating Engineering Society*, 2002; 31(1):109-118.
- 15 Boyce PR & Bruno LD, An evaluation of high pressure sodium and metal halide light sources for parking lot lighting, *Journal of the Illuminating Engineering Society*, 1999; 28; 16-32.
- 16 Chen L. The accuracy of color naming under different light sources at low photopic to low mesopic conditions, M.Sc. Thesis, Rensselaer Polytechnic Institute, Troy, New York, 1998
- 17 Lambe R, Potential pitfalls when using luxmeters and implications of lighting level on the relative efficiency of light sources, *Lightec 96*; Cambridge UK, 9-10 September 1996; 5-10.
- 18 Konica Minolta, Luminance meter LS-100 LS-110 instruction manual, Konica Minolta: Japan, 1987.
- 19 Bailey IL & Lovie JE, New design principles for visual acuity letter charts, *American Journal of Optometry and Physiological Optics*, 1976; 53(11); 740-745.
- 20 Vrabel PL, Bernecker CA, and Mistrick RG. Visual performance and visual clarity under electric light sources. Part 1. Visual performance, *Journal of the Illuminating Engineering Society*, 1995; 24: 69-80
- 21 Dunn-Rankin P, Knezek GA, Wallace S & Zhang S, *Scaling methods*. 2<sup>nd</sup> Edition, 2004; Lawrence Erlbaum Associates, Mahwah, New Jersey.
- 22 Field A, *Discovering statistics using SPSS*. 2005. London; SAGE Publications Ltd.

- 23 Coolican H, Research methods and statistics in psychology, 1994; Hodder & Stoughton, London, 2<sup>nd</sup> Edition.
- 24 Crow EL, Davis FA and Maxfield MW, Statistics manual, 1960; Dover Publications Inc, New York.
- 25 Moore DS and McCabe GP, Introduction to the practise of statistics, 1993; WH Freeman & Co; New York, 2nd Edition.
- 26 Navvab, M. (2001). A comparison of visual performance under high and low color temperature fluorescent lamps. Journal of the Illuminating Engineering Society, Vol. 30, No.2 pp.170-175.

### **Acknowledgement**

This work was carried out with support from EPSRC, grant references EP/F035624/1 and GR/T09385/01. Lamps and luminaires were supplied by Philips Lighting, Lemnis Lighting and Urbis Lighting; side-by-side booths were procured through a CIE-UK grant.



Lamp type	CCT (K)	CRI (R <sub>a</sub> )	Gamut Area Index	S/P
HPS	1855	4.6	6.7	0.48
MH2	3581	94.6	70.7	1.66
CFL2	5550	71.7	81.4	1.86
CPO	2953	70.8	44.2	1.25
LED	5022	30.2	20.1	2.80

**Table 1.** Description of the lamps used in preference and acuity tests. All properties were derived from SPD measured from observers view of test apparatus.

Comparison	Result for	Equal illuminance			Equal brightness		
		Hands	Colour array	Space	Hands	Colour array	Space
Spatial position (left-hand vs. right-hand booth)	left-hand booth	21	15	17	22	25	17
Lamp (CFL <sub>A</sub> vs. CFL <sub>B</sub> )	CFL <sub>A</sub>	24	24	22	19	22	20

**Table 2.** Results of brightness matching null-condition tests. Differences between the left and right hand booths, and between the two supposed identical CFL lamps, were not significant ( $p>0.05$ ) in all cases.

Object	Equality	Preference (%) for <i>first</i> lamp in each pair									
		CPO/ HPS	MH2/ HPS	LED/ HPS	CFL2 /HPS	MH2/ CPO	LED/ CPO	CFL2 /CPO	LED/ MH2	CFL2 /MH2	CFL2 /LED
Hand	Illuminance	74	82	55	68	42	39	24	24	11	55
Colour array	Illuminance	92	97	76	87	74	24	53	11	16	71
Space	Illuminance	74	89	61	76	68	32	53	16	24	71
Hand	Brightness	63	61	53	50	39	39	21	21	13	63
Colour array	Brightness	92	87	71	79	71	18	47	11	16	84
Space	Brightness	71	74	47	76	55	24	45	16	13	82

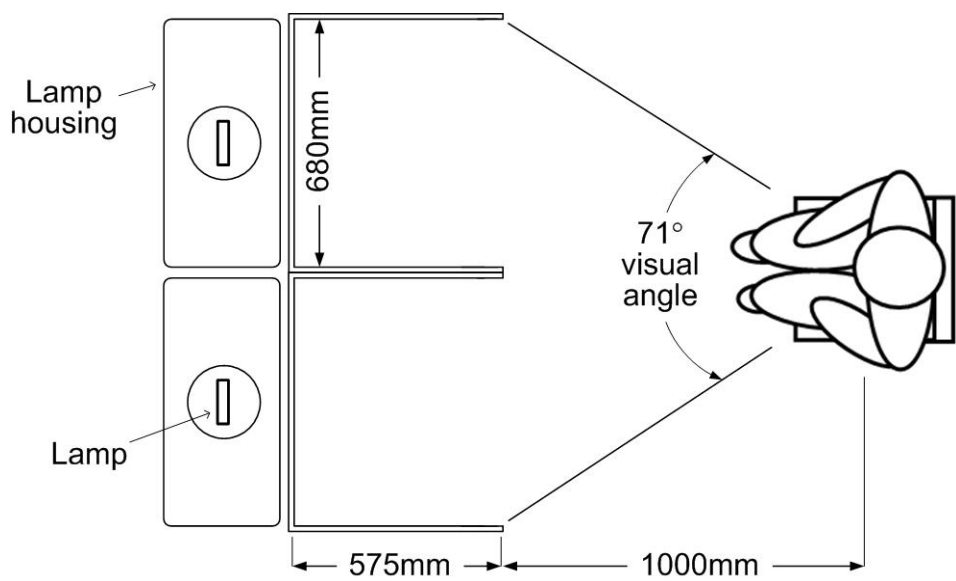
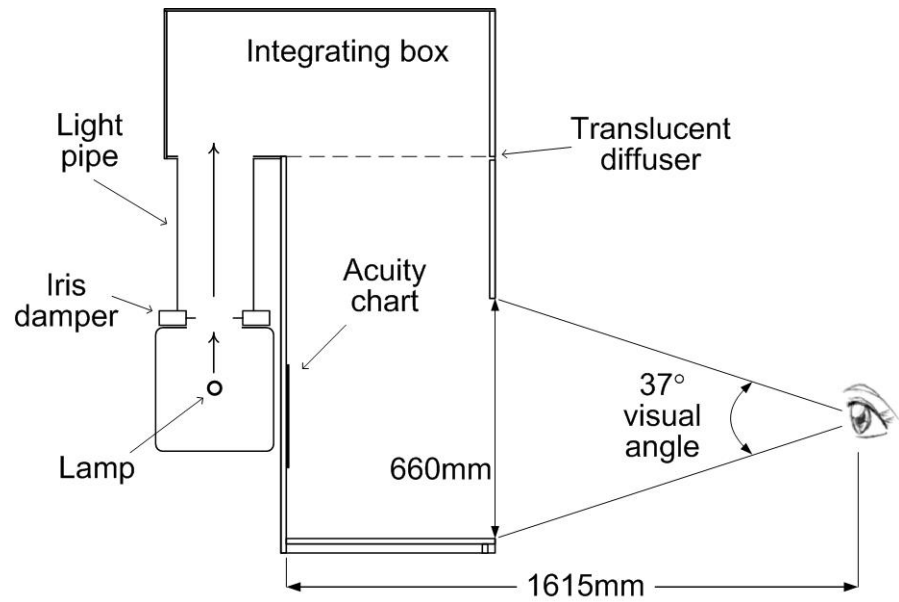
**Table 3.** Results of preferred appearance tests; percentage frequency by which the first lamp in each pair was reported to give preferred appearance of the target object. (n=38 in each case)

Appearance of hands				Appearance of colour array				Appearance of space			
Equal illuminance		Equal brightness		Equal illuminance		Equal brightness		Equal illuminance		Equal brightness	
HPS	46	CFL2	56	HPS	18	HPS	27	HPS	38	LED	40
CFL2	60	LED	57	LED	53	LED	44	LED	52	HPS	50
LED	62	HPS	66	CFL2	86	CFL2	86	CPO	84	CFL2	82
CPO	102	CPO	100	CPO	92	CPO	97	CFL2	85	CPO	94
MH2	110	MH2	101	MH2	131	MH2	126	MH2	121	MH2	114

**Table 4.** Overall preference scores and rank order of lamps. A high score indicates a high preference. Note: the maximum possible score in each case is 152, i.e. 38 subjects x 4 lamp pairs.

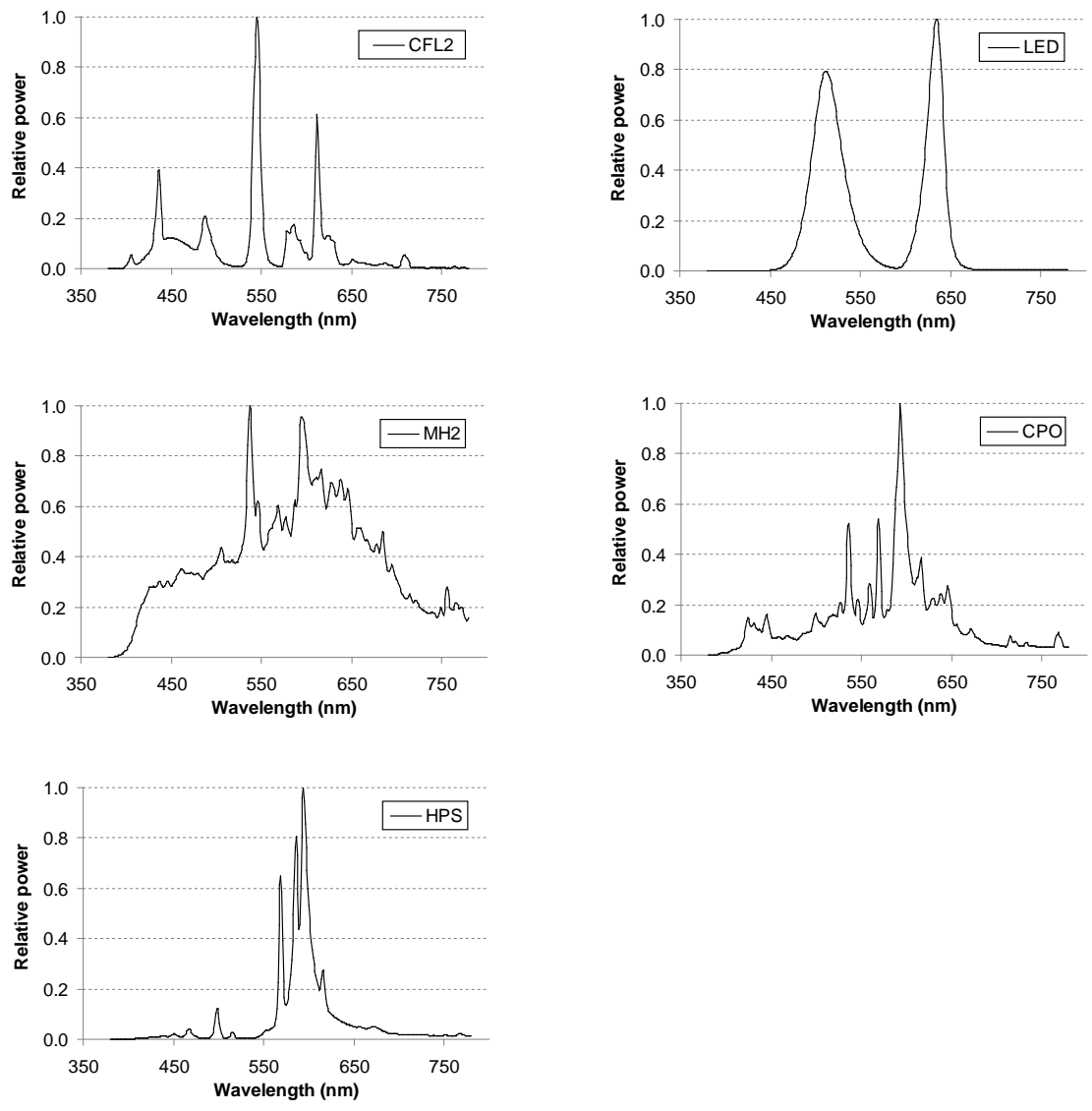
<b>Metric</b>	<b>Equal illuminance</b>			<b>Equal brightness</b>		
	<i>hands</i>	<i>colour array</i>	<i>space</i>	<i>hands</i>	<i>colour array</i>	<i>space</i>
CRI	0.83	0.98	0.85	0.64	0.93	0.55
GAI	0.55	0.81	0.81	0.42	0.83	0.61
S/P	0.23	0.31	0.15	0.07	0.17	0.01
CCT	0.05	0.20	0.09	<0.01	0.10	<0.01
CIE mesopic system	0.17	0.24	0.08	0.03	0.10	0.01

**Table 5.** Coefficient of determination ( $R^2$ ) between ratios of lamp metric and ratios of preference score.

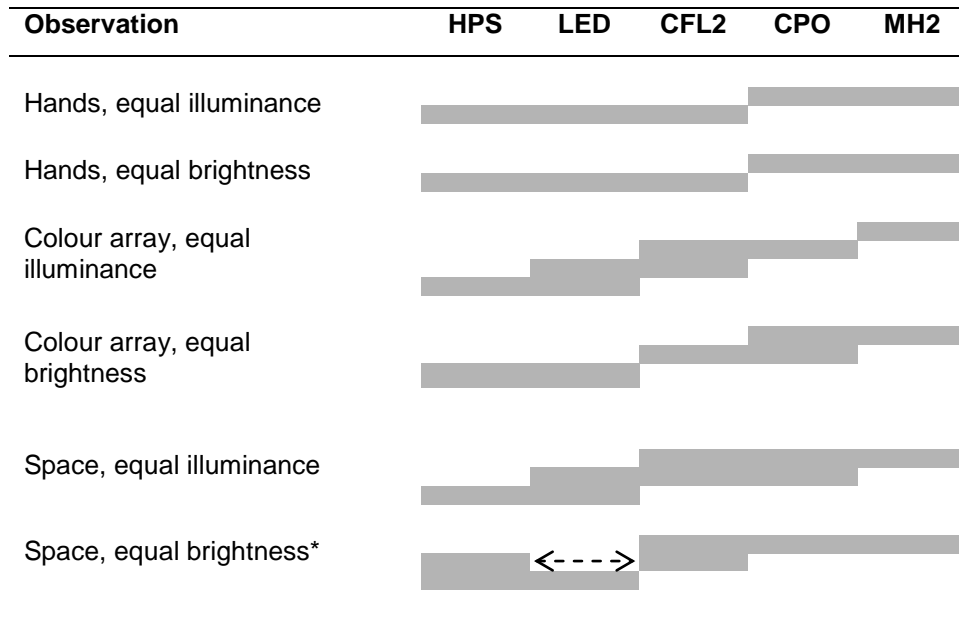


**Figure 1**

Vertical and horizontal sections through the side-by-side booths used in brightness ranking and brightness matching tests. The perpendicular distance from the back wall of the booths to the observer's eyes is 1575mm. When reading the acuity chart the observer remained seated in line with the central partition between the booths and this gives a distance of 1615mm between the observer's eyes and the acuity chart on the back wall of a booth.

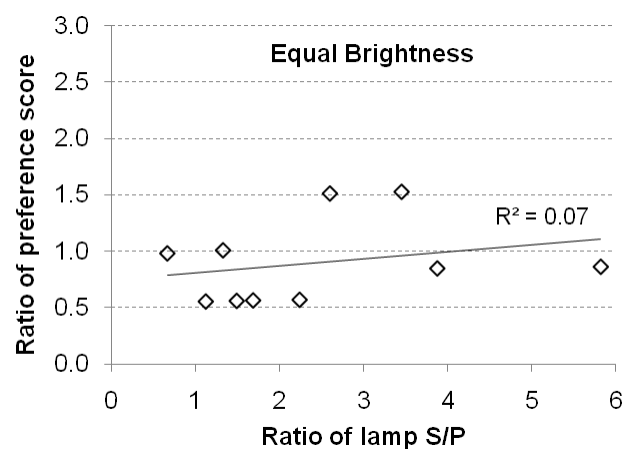
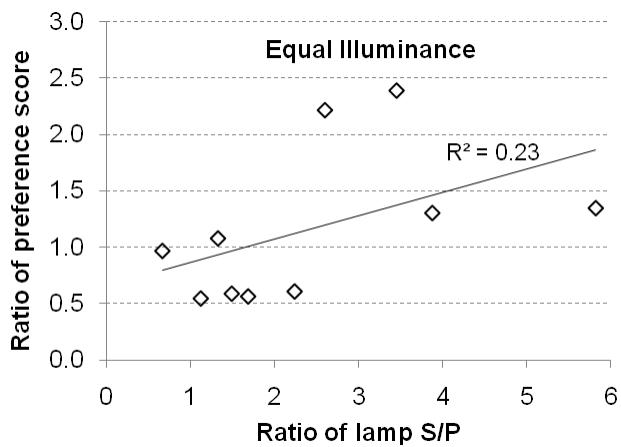
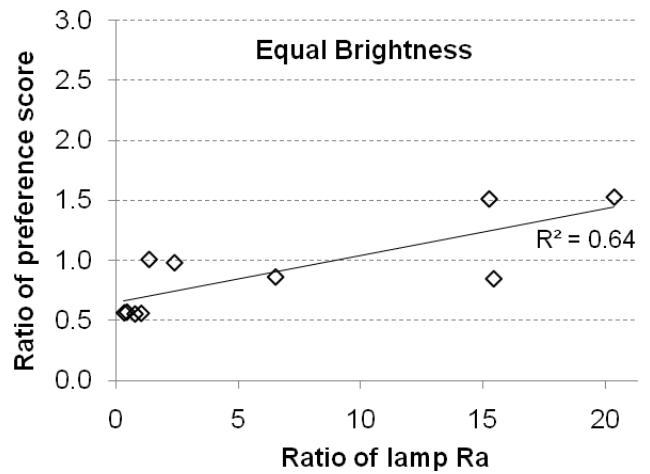
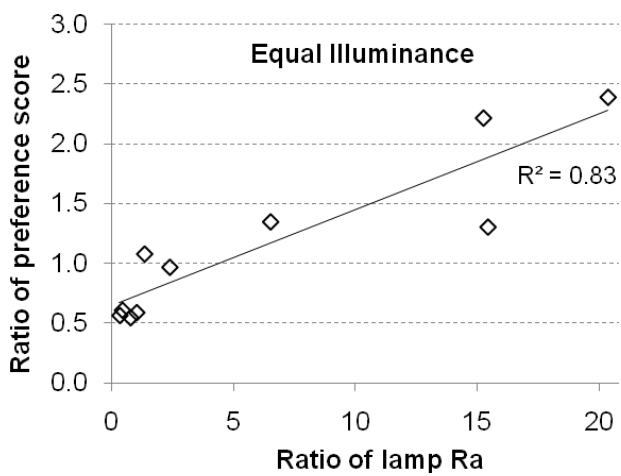


**Figure 2**  
Spectral power distributions of the test lamps. These are as measured from the observers view point and hence include modification by the test apparatus, and are normalised for a peak response of 1.0.

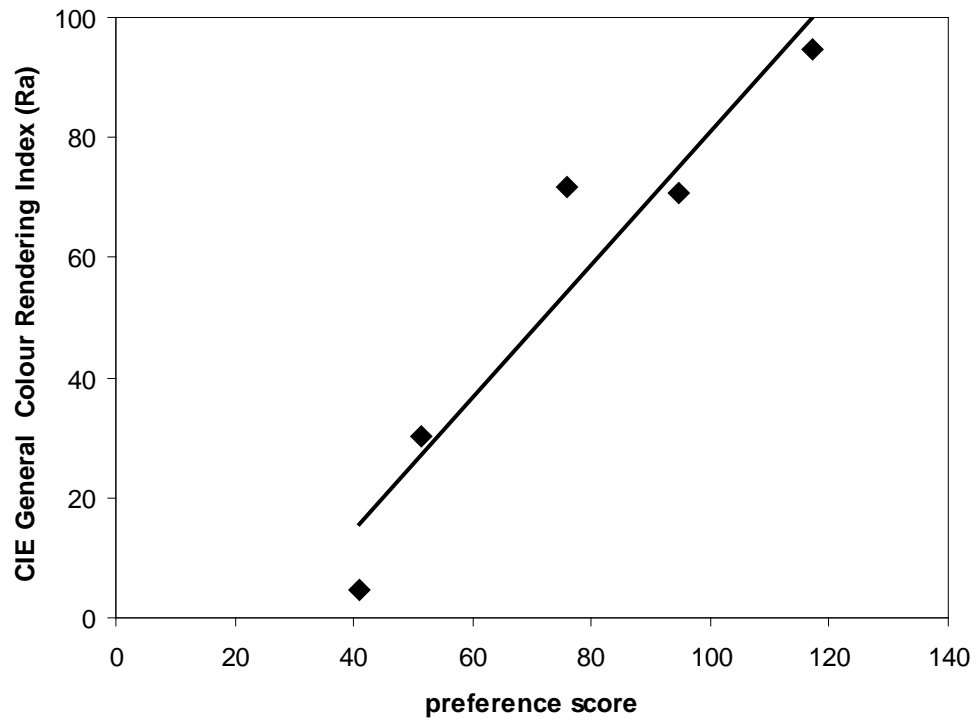


**Figure 3.** Results of analysis of preference judgements using Dunn-Rankin variance stable rank sums. This shows lamps which are not suggested to be significantly different (i.e.  $p > 0.05$ ) in preferred appearance judgements.

(\*Note: for preferred appearance of space at equal brightness, the HPS and CFL2 lamps have equal preference scores and the HPS and LED have equal preference, but the LED and CFL2 preference scores were different ( $p < 0.05$ )).

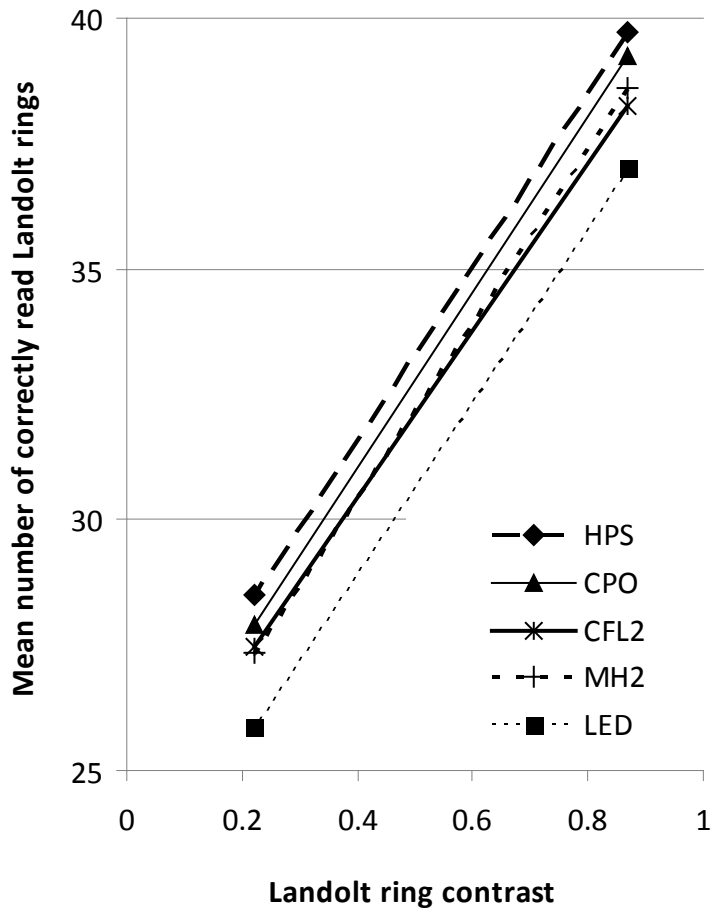


**Figure 4.** Results of the preference tests for the appearance of test subjects' hands. The left-hand graphs are for judgements made when the two booths were set to equal illuminance, and the right-hand graphs are for judgements made following a match for equal brightness.



**Figure 5.** Preference scores for the five lamps (the mean of judgements for appearance of hands, colours and space at equal illuminance and equal brightness) plotted against CRI ( $R^2=0.91$ ).





**Figure 6.** Results of the acuity tests; mean number of correctly read Landolt rings under five types of lamp at two target-background contrasts.