

This is a repository copy of *Double-Weibull distributions of the re-emission spectra from a non-linear device in a mode-stirred chamber*.

White Rose Research Online URL for this paper:

<https://eprints.whiterose.ac.uk/69732/>

Version: Published Version

Proceedings Paper:

Chen, J, Marvin, A C orcid.org/0000-0003-2590-5335, Flintoft, Ian David orcid.org/0000-0003-3153-8447 et al. (1 more author) (2010) Double-Weibull distributions of the re-emission spectra from a non-linear device in a mode-stirred chamber. In: 2010 IEEE International Symposium on Electromagnetic Compatibility:18-23 July, 2010. IEEE , Fort Lauderdale, Florida, USA , pp. 541-546.

<https://doi.org/10.1109/IEMC.2010.5711334>

Reuse

Items deposited in White Rose Research Online are protected by copyright, with all rights reserved unless indicated otherwise. They may be downloaded and/or printed for private study, or other acts as permitted by national copyright laws. The publisher or other rights holders may allow further reproduction and re-use of the full text version. This is indicated by the licence information on the White Rose Research Online record for the item.

Takedown

If you consider content in White Rose Research Online to be in breach of UK law, please notify us by emailing eprints@whiterose.ac.uk including the URL of the record and the reason for the withdrawal request.

Double-Weibull Distributions of the Re-Emission Spectra from a Non-Linear Device in a Mode Stirred Chamber

Chen Jiaqi, Andy Marvin, Ian Flintoft and John Dawson

*Department of Electronics, University of York
York, United Kingdom,*

acm@ohm.york.ac.uk jc532@york.ac.uk
idf1@ohm.york.ac.uk jfd@ohm.york.ac.uk

Abstract—A Double-Weibull distribution of the mean normalised field strength is used to formulate the statistical aspects of re-emission spectra in a reverberation chamber. Cumulative distributions of mean normalised measurement results are used to quantify the degrees of interaction between EUT and RF interference levels. This research is a precursor to digital device immunity diagnostic methodology on the statistics aspects independent from absolute magnitudes.

I. INTRODUCTION

When a digital device is illuminated by RF energy, harmonics of the RF frequency will arise as a result of the nonlinear interaction between threat energy and the DUT. Furthermore, new spectral components in the form of inter-modulation products between the device's internal signals and the threat frequency and its harmonics can be observed, if the RF level is high enough. This phenomenon is recognized as re-radiation or re-emission from a victim device under RF illumination. A reverberation chamber is the ideal environment to conduct investigations on re-radiation because its high Q environment enables the generation of high field strengths with a moderate input power level. The statistics of the scattered harmonic spectra re-radiated from a non-linear device in a mode-stirred chamber were described by a

Volterra series of Rayleigh random variables to describe the statistical features of measurement result under low illumination levels (soft non-linearity) [1]. The Volterra series expansion of cascaded Rayleigh process was modified using a Describing Function technique [2] to extend validity of analysis into higher power illumination (hard non-linearity). Monte-Carlo simulations were used to replicate the measurement scenarios in both methods. In this paper the Describing Function is incorporated into a Weibull random process cascaded with a Rayleigh, hence providing probability density functions of received re-emission spectra. Then it is proved that by adjusting the scale parameter of either the Weibull or Rayleigh process the statistics can be scale normalised and hence compared without altering the shape parameter of probability density function. This mitigates the unknown variances of the Rayleigh channels in a reverberation chamber that would be present between the antennas and the EUT in a real immunity measurement. Finally a K-S test [3] based on the distance between cumulative distribution function curves can be used to quantify how much is the difference between statistics at different RF threat levels.

The experimental set-up is shown in Fig.1.

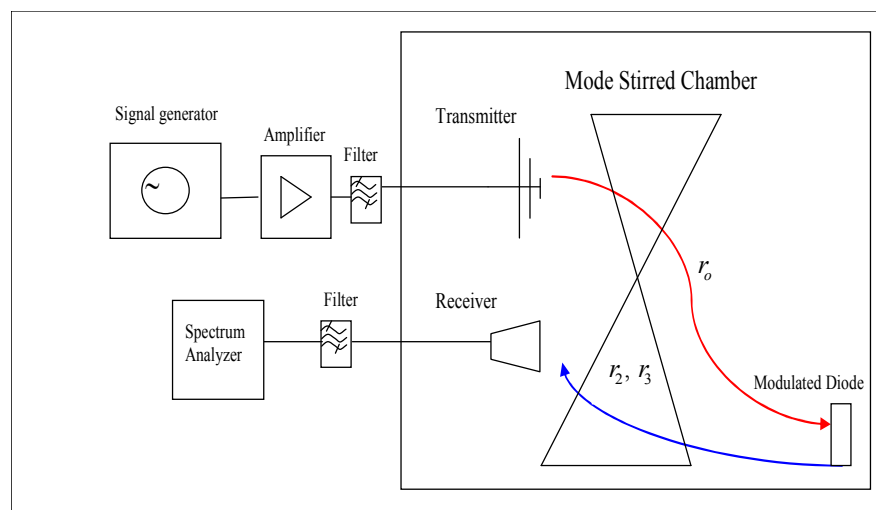

Fig 1 Instrumentation and Experiment Set up

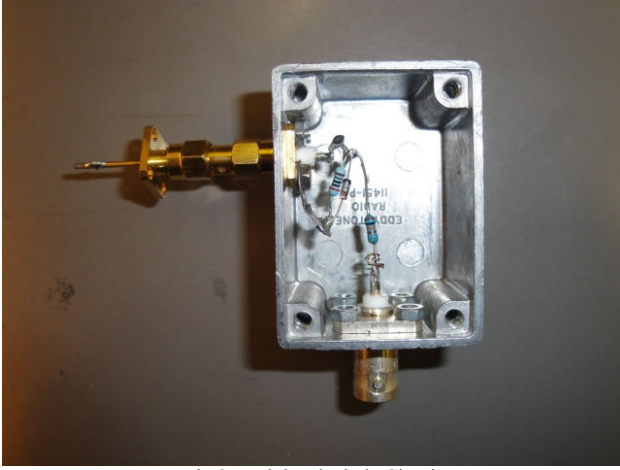

Fig.2 Modulated Diode Circuit

The simulated EUT is a diode circuit modulated by a 70MHz square wave digital clock. RF Power at 880MHz is radiated into the chamber and coupled into the circuit which inter-modulates between harmonics of both the RF carrier and the digital clock. Fig.2 shows the diode and its short monopole antenna mounted in a small enclosure. The harmonics together with the inter-modulation products power scattered from the circuit is re-radiated into the chamber and received by the Horn antenna. The Spectrum analyser is used to monitor the received power levels in the experiment.

II. DOUBLE-WEIBULL DISTRIBUTION

According to Describing Function Method [2] the relationship between incident field strength in voltage and the voltages of the received 2nd and 3rd harmonics, see Fig.1, is

$$v_2 = v_{source}^{n_2} \cdot [r_0]^{n_2} \cdot [r_2] \cdot \sqrt{c_{2,n_2}} \quad (1)$$

$$v_3 = v_{source}^{n_3} \cdot [r_0]^{n_3} \cdot [r_3] \cdot \sqrt{c_{3,n_3}} \quad (2)$$

Here c_{2,n_2} and c_{3,n_3} are constants depending on n_i ($i = 2, 3$). The term r_0 is the Rayleigh process between the transmitting antenna and the EUT and the terms r_m are Rayleigh processes between the EUT and the receiving antenna at harmonic number m . The index n_i is a function of incident power, which coupled into the device. If the self-emission of digital circuit is constant then similar relationship also applies to inter-modulation products at frequencies

$$f_{m,k} = m \cdot f_c + k \cdot f_{clk} \quad (3)$$

Here f_c is the carrier frequency of the incident RF energy and f_{clk} is the EUT clock frequency.

The incident field $v_{source} \cdot [r_0]$ can be viewed as Rayleigh random variable. If we define

$$v_{scat} = v_{source}^{n_i} \cdot [r_0]^{n_i} \quad (4)$$

v_{scat} as the voltage scattered from the non-linear EUT that is re-radiated into the chamber there follows a Weibull distribution with probability density function

$$p_{wb}(v_{scat}; \lambda_i, k_i) = \frac{k_i}{\lambda_i} \left(\frac{v_{scat}}{\lambda_i} \right)^{k_i-1} e^{-\left(\frac{v_{scat}}{\lambda_i} \right)^{k_i}} \quad (5)$$

where p_{wb} is the probability density function, $k_i = \frac{2}{n_i}$

$\lambda_i = (\sqrt{2}\sigma_0)^{n_i}$ are shape and scale parameters of a Weibull distribution respectively. Here σ_0 is the variance of Rayleigh channel from transmitter to EUT. Furthermore, when cascaded with another Rayleigh process, the received field v distribution density function can be derived see Fig.3.

$$p_{double_wb}(v, \sigma_0, \sigma_l, k_i) = \frac{v}{n_i \sigma_0^2 \sigma_l^2 v_{source}^{k_i}} \int_0^{+\infty} x^{k_i-3} e^{-\left(\frac{x^{k_i}}{2\sigma_0^2} + \frac{v^2/v_{source}^{k_i}}{2\sigma_l^2 x^2} \right)} dx \quad (6)$$

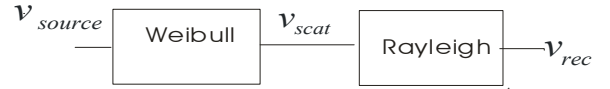

Fig.3 Double-Weibull distribution model

In (6) the probability density is dependent on threat field strength v_{source} , Rayleigh channel variances and shape parameter of first Weibull process. It is possible to simplify (6) by normalising the received field strengths by the mean value. Because the first Weibull process is independent from the cascaded Rayleigh, the mean value of received field

$$\mu_{Double-Weibull} = \mu_{Weibull} \cdot \mu_{Rayleigh} \quad (7)$$

where

$$\mu_{Weibull} = \lambda_i \cdot \Gamma\left(1 + \frac{1}{k_i}\right) = (\sigma_0 \sqrt{2})^{\frac{2}{k_i}} \Gamma\left(1 + \frac{1}{k_i}\right) \quad (8)$$

$$\mu_{Rayleigh} = \sigma_l \sqrt{\frac{\pi}{2}} \quad (9)$$

According to (7) to (9) the probability density function of mean normalised field can be derived by modifying scale parameters

$$\lambda_i = \Gamma^{-1}\left(1 + \frac{1}{k_i}\right) \text{ or } \sigma_0 = 1 / \sqrt{2 \Gamma^{k_i}\left(1 + \frac{1}{k_i}\right)} \quad (10)$$

$$\sigma_l = \sqrt{\frac{2}{\pi}} \quad (11)$$

Then probability density function for mean value normalised field is

$$P_{double_wb}(v; k) = \frac{k_i \cdot v \cdot \pi \cdot \Gamma(k_i) \left(1 + \frac{1}{k_i}\right)}{2} \int_0^{+\infty} x^{k_i-3} e^{-x^{k_i} \cdot \Gamma(k_i) \left(1 + \frac{1}{k_i}\right) \frac{v^2 \cdot \pi}{4x^2}} dx \quad (12)$$

The function (12) provides an analytical tool to quantify the statistics of mean value normalised re-emission spectra and is independent from absolute magnitude, see Fig. 4.

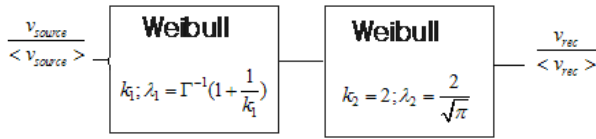

Fig.4 Mean normalised Double-Weibull distribution model
The probability density function is only related by shape parameter of Weibull distribution which is determined by circuit scattering profile under certain RFI level. This makes it possible to compare the re-emission spectrum statistics under different interference RF field levels, as an indicator for EUT immunity.

III. EXPERIMENTAL RESULTS

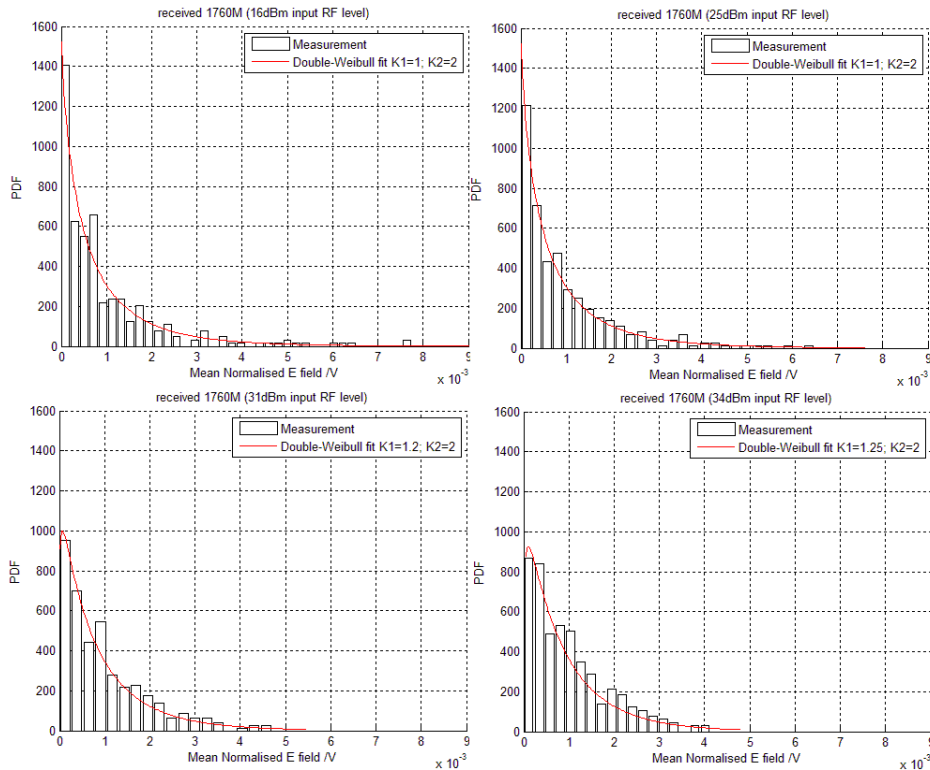

Fig.6 Probability density of mean normalised spectrum of 2nd harmonic

The mean incident and received power measurements for the 2nd (1760MHz) and 3rd (2640MHz) harmonics and inter-modulation products are shown in Fig. 5. These results are measured for 320 positions of the stirrer in the chamber. The gradients of the graphs change with input power levels indicating the nonlinear scattering follows different statistical distributions according to investigations in [2]. The probability density of mean normalised

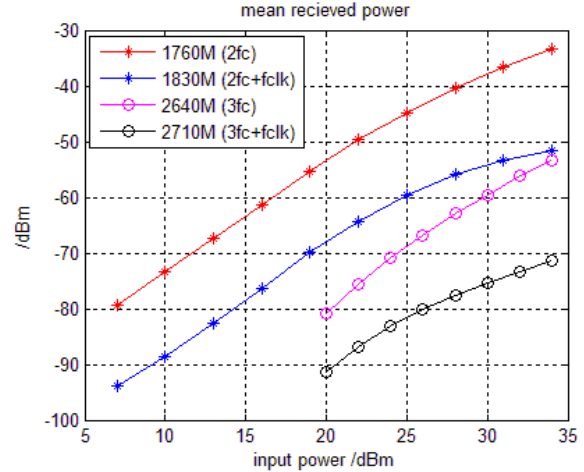

Fig.5 Mean Scattered Power from modulated diode circuit as measured at Spectrum Analyser A in Fig 1 as a function of input power to the chamber.

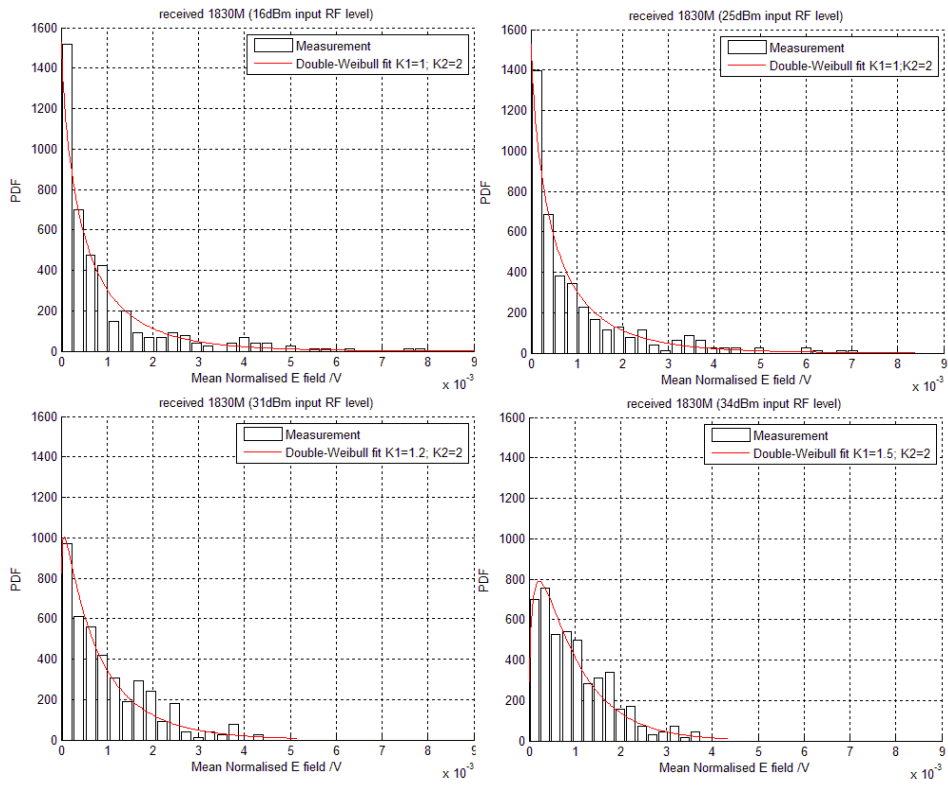

Fig.7 Probability density of mean normalised spectrum of inter-modulation between 2nd harmonic and digital clock

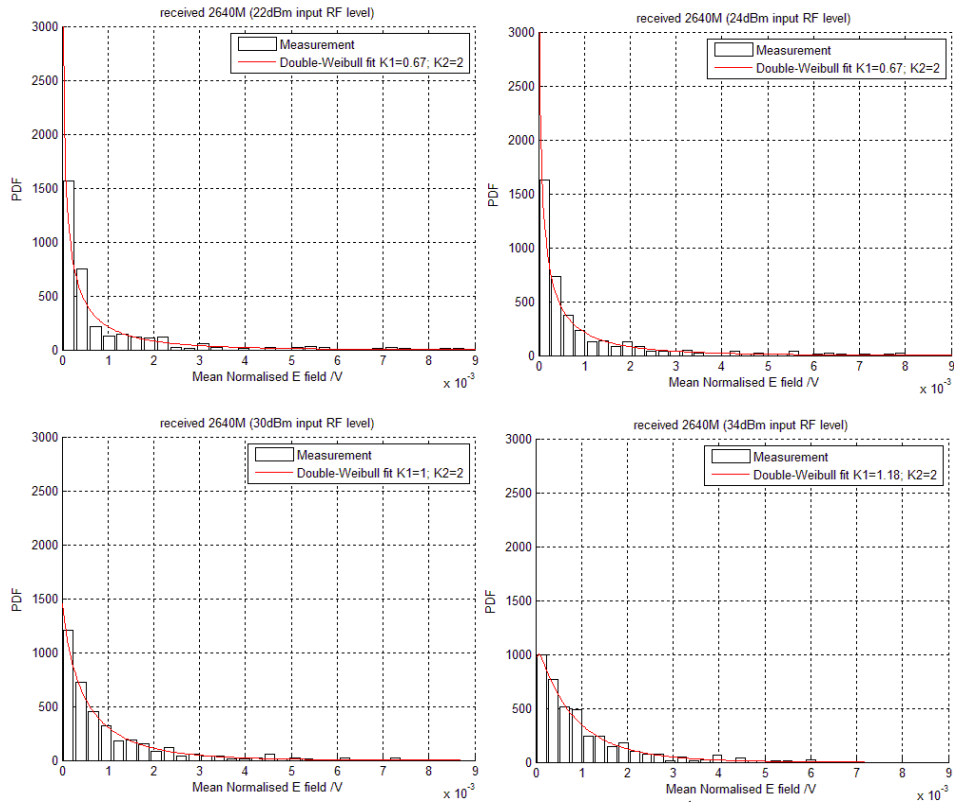

Fig.8 Probability density of mean normalised spectrum of 3rd harmonic

measurement results are plot Fig. 6 to Fig.8, which is fitted by Double-Weibull distribution discussed in section II.

In the cascaded linear channel model as depicted in Fig.4, the shape parameter of first Weibull process is only determined by nonlinear scattering properties of the EUT. It is related to the power gradient n_i as shown in Fig.5 in the form of $k_i = 2 / n_i$. Scalar parameters of both first Weibull and second Rayleigh (a special case of Weibull with k equals 2) process are assigned to satisfy their product has the same mean value as the normalised measurement data. As shown in Fig. 6 to Fig. 8, the measurement data is normalised with 1000 times of mean value so the mean value of Double-Weibull distribution is 0.001. Hence the shifting from soft nonlinear scattering to hard nonlinearity can be incorporated by varying shape parameter of a Double-Weibull distribution model as depicted in Fig. 4.

For typical soft nonlinearities, the second harmonic and its inter-modulation products follow a square law of the illuminating field at fundamental frequency, which corresponds to a Double-Weibull distribution with K1=1 and K2=2; The third harmonic and its inter-modulation products follow cubic law and the Double-Weibull distribution with K1=0.67 and K2=2. At highest input power level (hard nonlinearity) the Double-Weibull distribution of 1830MHz (2fc+fclk) spectrum evolves into

K1=1.5 and K2=2; the distribution of 3rd harmonic also change to K1=1.18, K2=2 which is almost like that of 2nd harmonic at lowest input level.

To make observation of the evolution of the statistics above more straightforward, the cumulative distribution function (13) is used as an alternative to density function. From Double-Weibull distribution density function (12) the cumulative distribution function P_{double_wb} can be derived as:

$$P_{double_wb}(v; k) = \int_0^v p_{double_wb}(x; k) dx \quad (13)$$

The degree of interactions between digital device and RFI can be observed from cumulative distribution of received inter-modulation spectra (1830MHz and 2710MHz), as shown in Fig.9. The curves of mean normalised field overlap when input RFI power is rather low, which indicates the operation of EUT is not influenced by threatening field significantly hence keeps consistency in the nonlinear scattering profile. However, the curves of high input power distinct and is evolving as the input increases.

The vertical gap between these cumulative distribution curves at the same x-axis index can be used to quantify the like-hood of distributions. From Fig.9 it is deduced the distribution of harmonics and inter-modulation products is altered when input power increases and the degree is more significant for inter-modulation products because both the status of device and the self-emission of clock signal are altered by RFI at high power level.

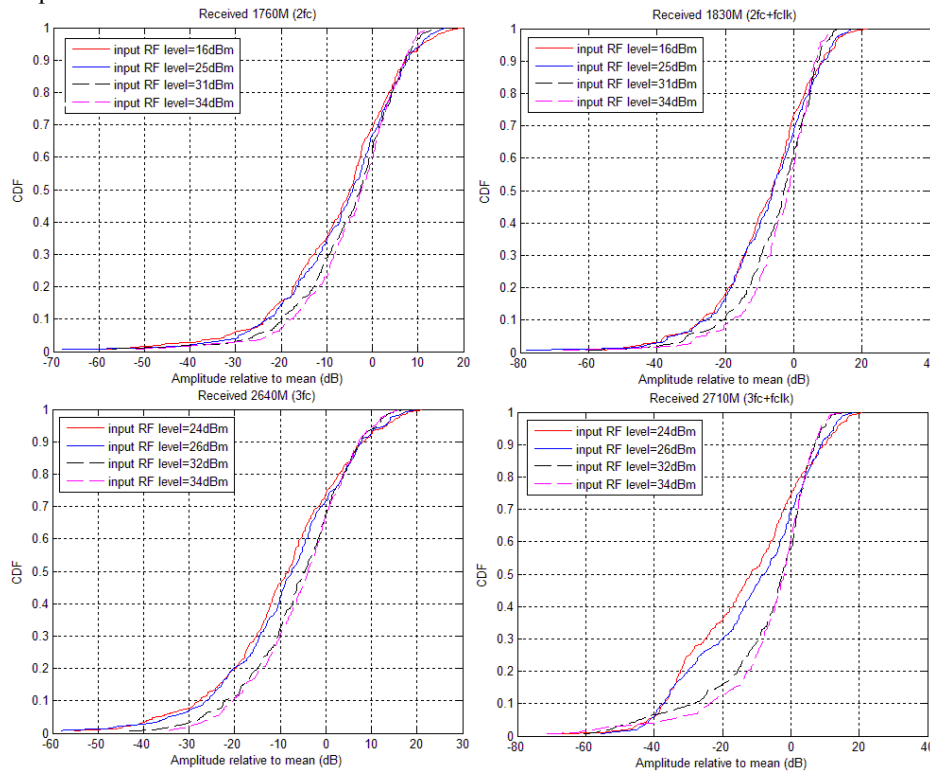

Fig. 9 Cumulative distributions of mean normalised spectrum

IV. DISCUSSION

The Double-Weibull distribution fits measurement data and validates that the statistical features of re-emission spectra are predictable and comparable after normalising. Hence it is possible to use the mean value normalised data to mitigate the unknown factors of actual propagation channel between EUT and transmitter and that between EUT and receiver antennas.

The previous work [4] shows the interactions of radiation into a digital electronic system can be tracked by measurement of the re-radiated spectrum of the system. Measurements are conducted in anechoic chamber and GTEM cell inspecting the gradient of received field strength against input. The inter-modulation between digital signal and RF interference is an indicator and used to diagnose failure. In latest work [2] the statistics of measured spectrums are used to achieve the same objectives but in a mode-stirred chamber. Compared with anechoic chamber and TEM cell techniques, the mode stirred chamber provides higher field intensity with a moderate input power and field uniformity independent from EUT positions. The Double-Weibull distribution proposed in this paper is based on the describing function method which is flexible to model transition from soft non-linearity to hard non-linearity. Compared with Monte Carlo simulations used in [2], Double-Weibull distribution is analytical and compatible with communication channel modelling tools.

Future work is investigating the statistics of re-emission spectrum of a complex digital system with multiple clock rates. The difference between distributions of received spectrums can be used to diagnostic which subsystem is close to malfunction when RFI reaches a certain level. Improvement in post processing numerical method is also the aim of this research. In this paper, mean normalised

data and its cumulative distributions are used to quantify the degree of immunity of digital device. Further study will try to adapt various high power goodness-of-fit tests to enhance the extraction of statistical characteristic features.

V. CONCLUSIONS

An improved modeling technique for the investigation of non-linear scattering in a mode-stirred chamber is proposed. The Double-Weibull distribution proposed here inherits the flexibility of describing function method and gives an analytical form of the distribution density function for the statistics of interest. By applying this method to mean value normalized data measurement results on different absolute magnitude scales can be comparable and not dependent on actual Rayleigh channel parameters in the chamber.

It has been demonstrated that the statistical distribution of the re-emissions changes with the intensity of the input threat field. It is proposed that this observation will lead to a diagnostic immunity tool for use in reverberation chambers.

VI. REFERENCES

- [1] A C Marvin, I D Flintoft & Linda Dawson. "Statistical Response of Non-Linear Equipment in a Reverberation Chamber". *IEEE 2008 Symposium on EMC*, 18-22 Aug, 2008.
- [2] A C Marvin, Chen Jiaqi, I D Flintoft & John Dawson. "A describing function method for evaluating the statistics of harmonics scattered from a non-linear device in a reverberation chamber". *IEEE Symposium on EMC*, Aug, 2009.
- [3] Christophe Lemoine, Philippe Besnier, Mhamed Drissi. "Investigation of Reverberation Chamber Measurements Through High Power Goodness-of-fit Tests". *IEEE transaction on EMC*, vol 49, No.4 2007.
- [4] I D Flintoft, A C Marvin, M P Robinson, K Fischer & A J Rowell. "The re-emission spectrum of digital hardware subjected to EMI". *IEEE Transactions on EMC*, Vol. 45, No. 4, pp 576 - 585, November, 2003. ISSN: 0018-9375