

This is a repository copy of *Diversity and specificity of Rhizobium leguminosarum biovar viciae on wild and cultivated legumes*.

White Rose Research Online URL for this paper:

<https://eprints.whiterose.ac.uk/415/>

Article:

Mutch, L A and Young, J P W orcid.org/0000-0001-5259-4830 (2004) Diversity and specificity of *Rhizobium leguminosarum* biovar *viciae* on wild and cultivated legumes. *Molecular Ecology*. pp. 2435-2444. ISSN 0962-1083

<https://doi.org/10.1111/j.1365-294X.2004.02259.x>

Reuse

Items deposited in White Rose Research Online are protected by copyright, with all rights reserved unless indicated otherwise. They may be downloaded and/or printed for private study, or other acts as permitted by national copyright laws. The publisher or other rights holders may allow further reproduction and re-use of the full text version. This is indicated by the licence information on the White Rose Research Online record for the item.

Takedown

If you consider content in White Rose Research Online to be in breach of UK law, please notify us by emailing eprints@whiterose.ac.uk including the URL of the record and the reason for the withdrawal request.

Diversity and specificity of *Rhizobium leguminosarum* biovar *viciae* on wild and cultivated legumes

LESLEY A. MUTCH* and J. PETER W. YOUNG

Department of Biology (Area 3), University of York, PO Box 373, York YO10 5YW, UK

Abstract

The symbiotic partnerships between legumes and their root-nodule bacteria (rhizobia) vary widely in their degree of specificity, but the underlying reasons are not understood. To assess the potential for host-range evolution, we have investigated microheterogeneity among the shared symbionts of a group of related legume species. Host specificity and genetic diversity were characterized for a soil population of *Rhizobium leguminosarum* biovar *viciae* (*Rlv*) sampled using six wild *Vicia* and *Lathyrus* species and the crop plants pea (*Pisum sativum*) and broad bean (*Vicia faba*). Genetic variation among 625 isolates was assessed by restriction fragment length polymorphism (RFLP) of loci on the chromosome (ribosomal gene spacer) and symbiosis plasmid (*nodD* region). Broad bean strongly favoured a particular symbiotic genotype that formed a distinct phylogenetic subgroup of *Rlv* nodulation genotypes but was associated with a range of chromosomal backgrounds. Host range tests of 80 isolates demonstrated that only 34% of isolates were able to nodulate *V. faba*. By contrast, 89% were able to nodulate all the local wild hosts tested, so high genetic diversity of the rhizobial population cannot be ascribed directly to the diversity of host species at the site. Overall the picture is of a population of symbionts that is diversified by plasmid transfer and shared fairly indiscriminately by local wild legume hosts. The crop species are less promiscuous in their interaction with symbionts than the wild legumes.

Keywords: domestication, host range, legumes, *nodD*, *Rhizobium leguminosarum* bv. *viciae*, symbiosis

Received 17 February 2004; revision received 18 May 2004; accepted 18 May 2004

Introduction

Legumes are an important component of all agricultural systems because of the nitrogen fixation provided by their bacterial symbionts, the rhizobia (O'Hara *et al.* 2003). The successful spread of legume crops depends critically on the availability of compatible rhizobia. The nature of the symbiosis was first understood at the end of the 19th century, and since then a number of crops have been introduced to new areas with the help of rhizobial inoculants. For example, the cultivation of soybean (a Chinese domestication) in the United States depended on deliberate inoculation with *Bradyrhizobium japonicum* (Lohrke *et al.* 1996). In more recent examples, the use of European *Lotus*

corniculatus as a forage legume in New Zealand (Sullivan *et al.* 1995) and Asian *Cicer arietinum* (chickpea) as a grain legume in Australia (Howieson *et al.* 2000) required the introduction of the corresponding symbionts. In these examples, the soils lacked appropriate indigenous rhizobia, and few or no nodules formed in the absence of inoculation.

Peas (*Pisum sativum*) and broad beans (*Vicia faba*) were domesticated originally in the Middle East, but have been cultivated in northern Europe for several thousand years (Bond 1996). They are both nodulated by *Rhizobium leguminosarum* biovar *viciae* (henceforth abbreviated to *Rlv*), which is ubiquitous in European arable soils. These crop species differ from the recent introductions mentioned above, because there are wild hosts (vetches and vetchlings, species of *Vicia* and *Lathyrus*) and compatible root nodule bacteria (*Rlv*) throughout Europe. Did the symbionts spread along with the crops, or are the peas and beans making use of indigenous symbionts of native wild plants?

All rhizobia show host specificity to a greater or lesser degree, and *Rlv* is said to nodulate all species in the tribe

Correspondence: J. Peter W. Young. Fax: +44 (0) 1904 328505; E-mail: jpy1@york.ac.uk

*Present address: Centre for *Rhizobium* Studies, School of Biological Sciences and Biotechnology, Division of Science, Murdoch University, South Street, Perth 6150, Western Australia.

Viciae, which comprises the genera *Vicia*, *Lathyrus*, *Pisum* and *Lens* (Allen & Allen 1981). However, a number of studies using domesticated legumes have demonstrated genetic differences in specificity among strains of *Rlv*. Some varieties of pea (*P. sativum*) from Afghanistan are nodulated only by a subset of *Rlv* strains that are found predominantly in the region from Turkey to Afghanistan, which is also thought to include the original domestication site of the plant (Young & Matthews 1982; Young *et al.* 1982; Lie *et al.* 1987). The genes *sym-2* in the plant and *nodX* in the rhizobium (Davis *et al.* 1988; Firmin *et al.* 1993; Geurts *et al.* 1997) confer this specificity. By contrast, peas grown elsewhere, including modern cultivars, have the alternate allele of *sym-2* that allows them to nodulate with a much wider range of *Rlv* strains. This suggests the possibility that the earliest cultivated peas had a narrow specificity, but the subsequent range expansion depended on a genetic change that allowed the plants to nodulate with native rhizobia that did not have the *nodX* gene. Further evidence of specificity differences within *Rlv* is provided by observations that different crop species select different subsets of the rhizobial population from the same soil (Hynes & O'Connell 1990; Evans *et al.* 1996; Handley *et al.* 1998; Laguerre *et al.* 2003).

The genetic diversity of the rhizobia on pea crops in the United Kingdom is high, despite the genetic uniformity of the host plants (Young & Wexler 1988; Handley *et al.* 1998; Palmer & Young 2000). This diversity is seen both at chromosomal loci and in the *nod* (nodulation) genes that mediate the signalling interaction with the plant (the *nod* genes are plasmid-encoded in this species). One possible explanation for the diversity might be that the spread of pea cultivation was successful because peas had, or acquired, a relatively broad symbiotic specificity, and are now forming a symbiosis with rhizobia that were originally specialists on various native wild hosts within the Viciae. If this were the case, then one would expect each wild species to be nodulated by a narrower subset of the types found on pea. Alternatively, the variation might be unrelated to host range, in which case there should be no difference in the rhizobia sampled from a population by different plant species.

Most research on rhizobium populations focuses on cultivated crops, often growing outside the natural range of their wild ancestors (e.g. Young *et al.* 1982, 1987; Young 1985; Wang *et al.* 1986; Lie *et al.* 1987; Schofield *et al.* 1987; Young & Wexler 1988; Hynes & O'Connell 1990; Laguerre *et al.* 1992, 1993; Geniaux & Amarger 1993; Demezas *et al.* 1995). Although there have been some surveys of 'wild' rhizobia, there has been little systematic comparison of the symbionts of wild and cultivated legumes, nor between populations in cultivated and uncultivated soils. One potential difference was suggested by Wernegreen *et al.* (1997), who isolated rhizobia from native Californian

clovers. They noted a strong association between chromosomal and plasmid genetic variants and concluded that there was a lack of successful plasmid transfer, in contrast to the findings of published studies on agricultural crops. However, as Souza & Eguiarte (1997) pointed out, the data do in fact suggest some limited plasmid transfer. Evidence for chromosomal recombination was also found in *Rhizobium etli* from traditionally managed bean (*Phaseolus vulgaris*) plots in Mexico (Silva *et al.* 1999). The genetic diversity of rhizobia in these plots was lower than that in intensively managed plots, but the diversity on wild beans was lower still (Souza *et al.* 1997). There are some indications therefore that diversity may be higher and recombination more prevalent in agricultural situations than in wild populations, but the evidence is far from conclusive.

In this study we examine the genetic diversity and the host specificity of *Rlv* strains sampled from the same uncultivated soil by four local wild legume species, two nonlocal wild species, and two introduced crops (pea and broad bean). The nodules were formed under controlled laboratory conditions in order to focus on host plant effects and avoid the potentially confounding influence of environmental microheterogeneity. The major questions are (i) whether differing preferences of the local hosts explain the maintenance of diversity in the rhizobial population, and (ii) whether the spread of crop plants beyond the range of their native ancestors has selected for less stringent symbiotic specificity.

Materials and methods

Sampling strategy and location

Rhizobia were sampled from the nodules of four wild legume species that grow locally (*V. cracca*, *V. hirsuta*, *V. sativa*, *L. pratensis*), two nonlocal wild species (*L. aphaca*, *L. nissolia*) and two introduced crops (pea, *Pisum sativum* cv. Kelvedon Wonder and broad bean, *V. faba* cv. The Sutton) grown in the same soil. The soil was collected from an established plant community on the University of York campus, York, UK (National Grid Reference: SE 619502), uncultivated for more than 30 years. The vegetation was mixed trees, shrubs, grasses and herbs, including *V. cracca*, *V. sativa* and *L. pratensis*. Sufficient topsoil (pH 6.2) was removed from a single plot approximately 2 m², to a depth of 20 cm, once above-ground vegetation and the majority of large roots had been discarded. Soil was taken back to the laboratory, mixed thoroughly and potted into 8 cm (0.25 L) or 13 cm (0.7 L) sterilized pots. Seed was obtained from Emorsgate Wild Seeds, King's Lynn, Norfolk (*L. aphaca* and *L. nissolia*), John Chambers Wild Flower Seeds, Kettering, Northamptonshire (other wild species) and Nickerson Zwaan (UK), Rothwell, Lincolnshire (crop species). Surface-sterilized seeds were allowed to germinate on TY agar

(Beringer 1974). Optimum pregermination treatments for each species were reached after preliminary tests. Seeds were vernalized ($-20\text{ }^{\circ}\text{C}$, 24 h, *L. nissolia* only), scarified, rinsed in absolute ethanol, sterilized appropriately (10% NaOCl/10 min for *V. cracca*, *V. faba*, *P. sativum*; 5%/10 min for *V. sativa*; 5%/5 min for *V. hirsuta*, *L. aphaca*, *L. nissolia*, *L. pratensis*), rinsed five times in sterile deionized water and imbibed for 24 h before planting out. Eighty seedlings of each species (except 40 seedlings of *L. pratensis* and 15 of *L. nissolia*), with no visible bacterial contamination, were transferred from agar into pots of soil (five seedlings per pot). Pots were placed in a Conviron growth chamber (16 h photoperiod; $18\text{ }^{\circ}\text{C}$ – $15\text{ }^{\circ}\text{C}$ day–night temperature; light flux $\sim 500\text{ }\mu\text{mol}$; 65% relative humidity) for 5–8 weeks. Control sterile seedlings of each host plant were placed in sterile Terra-Green growth medium (calcined attapulgitic clay; OilDri UK Ltd, Wisbech, Cambridgeshire, UK). All pots were watered with deionized water from below to prevent splash-over.

Bacterial isolation

Two arbitrarily selected nodules from each plant were rinsed in absolute ethanol, surface sterilized in 3% NaOCl (2–5 min) and then rinsed five times with sterile deionized water. Nodules were crushed and streaked onto TY agar. Plates were incubated at $27\text{ }^{\circ}\text{C}$ for 3–5 days then restreaked to obtain single colonies. Isolates were stored frozen in 20% glycerol at $-80\text{ }^{\circ}\text{C}$. Strain nomenclature indicates host plant and isolate number (e.g. isolate 6 from a *V. cracca* host plant is Vc6).

Strain authentication and host range

Ten randomly chosen isolates from each original host were tested for their symbiotic ability on each of the host species (except *L. aphaca*, for which insufficient seed was available). Sterile seedlings (as above) were grown in test-tube slants ($150 \times 24\text{ mm}$) or 500 mL flasks (peas and beans), on 1/4-strength modified Jensen's nitrogen-free agar, 20 mL and 150 mL, respectively (Somasegaren & Hoben 1994). Two replicate seedlings at day 5 after germination were inoculated with each selected rhizobium isolate and grown in a controlled environment (as above) for between 28 and 42 days. The symbiosis was scored visually as Fix+ (pink nodules and green plants, indicative of N fixation), Fix- (white nodules and yellowing plants, no N fixation), or Nod- (no nodulation by day 42).

Polymerase chain reaction–restriction fragment length polymorphism (PCR–RFLP) analysis

DNA extraction from bacterial cultures for subsequent molecular work was as in Zézé *et al.* (2001). Primers

FGPS1490 and FGPL132' were used to amplify the 16–23S rDNA *ITS* region (Laguerre *et al.* 1996). Primers NBA12 and NBF12' were used to amplify the sequence between the conserved *nod* box sequences of the promoter regions of genes *nodA* and *nodF*, flanking the *nodD* (Laguerre *et al.* 1996) and for strains in which this yielded no product, NBA12 was used with Y6 (Zézé *et al.* 2001), which is within *nodD*. Primers were synthesized by Cruachem, UK. Each 50 μL PCR reaction contained 1 μL template preparation (above), $1\times$ reaction buffer, 3 mM MgCl_2 , 1 unit *Taq* polymerase (Gibco Life Technologies, UK), 0.2 mM each dNTP and 16 pmol of each primer. The temperature cycle was $94\text{ }^{\circ}\text{C}$ for 120 s, 25 cycles of $93\text{ }^{\circ}\text{C}$ for 60 s, $55\text{ }^{\circ}\text{C}$ for 60 s and $72\text{ }^{\circ}\text{C}$ for 120 s, with a final extension of $72\text{ }^{\circ}\text{C}$ for 5 min.

ITS and *nodDF* PCR products (8 μL) were digested with 10 units *TaqI* or *MspI* (Promega, UK), respectively (Laguerre *et al.* 1996). Products from a subset of isolates were also digested with *HaeIII* or *AluI*. RFLP patterns were scored manually.

DNA sequencing

To position the isolates on a *nodD* phylogeny, representatives of each *nodDF*–*MspI* PCR–RFLP type were selected for sequence analysis. Forward primer LMD (5'-aat cga ata gca acc atc cc-3') was designed to be used as a sequencing primer with Y6 (Zézé *et al.* 2001) enabling full sequencing of the NBA12 and NBF12' PCR product on both strands. Purified products (QIAquick PCR Purification Kit, Qiagen) were sequenced using ABI PRISM™ Dye Terminator Cycle Sequencing Ready Reaction Kit With Amplitaq® DNA Polymerase FS (Applied Biosystems). PCR amplification and subsequent DNA precipitation were performed following the manufacturer's instructions. Products were run on an Applied Biosystems ABI PRISM™ 377 DNA Sequencer, following standard conditions as recommended by the manufacturer. Sequences were assembled and checked using AutoAssembler (Applied Biosystems), then analysed using CLUSTALX (Thompson *et al.* 1997). All phylogenetic relationships were calculated using the neighbour-joining algorithm with the Kimura 2-parameter model (excluding positions with gaps). Trees were displayed in TREEVIEW (Win32) version 1.6.6 (<http://taxonomy.zoology.gla.ac.uk/rod/rod.html>).

The EMBL Accession nos for the *nodD* gene sequences are AY226876–AY226890 and AY245528–AY245531.

Results

The isolates and their host specificity and effectiveness

A total of 625 rhizobium strains were obtained from the field soil sample by isolation from root nodules on the locally occurring wild legumes *V. cracca* (81 isolates), *V.*

Original host	Test host						
	V.c.	V.h.	V.s.	L.p.	L.n.	V.f.	P.s.
<i>Vicia cracca</i>	10*	9 (1)	8 (2)	8	1 (2)	2	9 (1)
<i>V. hirsuta</i>	10	10	9 (1)	10	10	1	6 (1)
<i>V. sativa</i>	8	10	10	10	10	3	10
<i>L. pratensis</i>	9 (1)	10	9 (1)	10	8 (2)	2 (1)	9 (1)
<i>Lathyrus aphaca</i>	2 (5)	10	10	10	10	4	10
<i>L. nissolia</i>	5 (5)	7 (3)	10	9	10	2	3 (4)
<i>V. faba</i>	10	9	10	10	10	10	6 (3)
<i>Pisum sativum</i>	9 (1)	10	8 (2)	10	10	2	10
% Effective strains†	78.8	93.8	92.5	96.3	86.3	32.5	78.8

*Number of isolates, of 10 tested, that formed a nitrogen-fixing symbiosis (Fix⁺). In parentheses is the number of additional isolates that formed nodules but did not fix nitrogen (Fix⁻).

†Overall percentage of the 80 isolates that were Fix⁺ on the corresponding test host.

hirsuta (98), *V. sativa* (88) and *L. pratensis* (47), the nonlocal wild legumes *L. aphaca* (92) and *L. nissolia* (10) and the cultivated species *V. faba* (90) and *Pisum sativum* (119). The number from host species varied with the availability of viable plants and success in establishing pure bacterial cultures. Ten randomly chosen isolates from each original host were tested for their symbiotic ability on each of the host species (except *L. aphaca*, for which insufficient seed was available). All the isolates were able to fix nitrogen with at least some of the hosts (Table 1). Most combinations of host and rhizobium formed an effective (i.e. nitrogen-fixing) symbiosis, but only 14 of the 80 isolates were able to fix nitrogen with all the host species, and none of the host species were able to form an effective symbiosis with all the isolates. Of the 560 host-strain combinations tested, 76 failed to form any nodules despite repeated tests, while a further 37 formed nodules but without effective nitrogen fixation. The broad bean, *V. faba*, was the most discriminating host, forming an effective symbiosis with just 16 of the 70 isolates obtained from other species. On the other hand, each of the 10 strains isolated from *V. faba* was effective on all or most of the other hosts. Among the wild legumes, *V. cracca* was most discriminating (17 strains failed to form effective nodules), although the most striking specific interaction was perhaps the failure of nine of 10 of the *V. cracca* isolates to form an effective symbiosis with *L. nissolia*.

Genetic diversity of the isolates

Chromosomal variation was assessed by amplification and restriction digestion of the ribosomal RNA 16S-23S intergenic spacer (ITS). Each isolate produced a single band ranging from 1100 base pairs (bp) 1350 bp. Nine distinct *TaqI* restriction patterns were identified among the 625 isolates. Each host species was nodulated by a number

Table 1 Host range of *Rhizobium leguminosarum* biovar *viciae* isolates

of different ITS types, so that in general they appear to share a similar pool of symbiotic strains (Table 2). There are, however, some differences in frequency. Most notably, 54% of strains from *V. cracca* were of type ITS-1 but this type was never recovered from *V. faba*.

Variation in the symbiosis gene cluster, which is plasmid-borne in *Rlv*, was examined by RFLP of the region between the Nod box regulatory sequence for *nodA* (using the primer NBA12) and that for *nodF* (NBF12'). In the well-characterized *Rlv* symbiosis plasmid pRL1JI (accession Y00548) and in *R. leguminosarum* biovar *trifolii* (X03721), the region amplified by these primers includes the entire *nodD* gene and some intergenic sequence up- and downstream of this gene. The majority of strains yielded an amplification product in the expected size range, between 1250 and 1400 bp. By digestion with *MspI* these were split into five RFLP classes. A single strain gave a much longer amplification product, about 2200 bp. Its *MspI* digestion pattern, type 6, had all the bands of type 3 plus additional bands that appeared to be due to an insertion of approximately 900 bp in the region between *nodD* and *nodF*.

A significant fraction of the isolates, 131 of 625, consistently did not yield any PCR product with the NBA12-NBF12' primer pair. However, amplification using a reverse primer internal to the *nodD* gene (NBA12-Y6) was successful, confirming that these isolates do have a *nodD* gene. Attempts at amplification of the *nodD-nodF* ITS of these isolates with LMD-NBF12' primers did not generate PCR products, suggesting either mismatches in the NBF12' target site or an insertion or rearrangement between the *nodD* gene and the *nodF*. For the purposes of this study, the nonamplifying strains were grouped together as *nodDF* type 7.

All the more common *nodDF* patterns were found among isolates from each of the host species, with the sole exception of *nodDF*-3, which was completely absent from

Table 2 Genotypes of rhizobia isolated from root nodules on eight host legume species growing in the same soil

Genotype		Local wild hosts			Nonlocal wild hosts			Cultivated hosts		Total
<i>nodDF</i>	<i>ITS</i>	<i>V. cracca</i>	<i>V. hirsuta</i>	<i>V. sativa</i>	<i>L. pratensis</i>	<i>L. aphaca</i>	<i>L. nissolia</i>	<i>V. faba</i>	<i>P. sativum</i>	
1	1	39	7	11	6	9	1		13	86
1	2	3	4	2						9
1	3	4	1	5		3	3	2	3	21
1	4		1		1	1		1	6	10
1	5							1	6	7
1	6								1	1
1	7			1						1
2	2		1	1				20	4	26
2	3	2	2	1		3		14	2	24
2	4	2						8	2	12
2	5		1	1		1		28		31
2	6			1				12		13
2	8							1		1
3	1	4	1	1		1			8	15
3	2	11	18	11	7	7	2		31	87
3	3	4	2	4	4	5			7	26
3	4	5	14	9	1	17			13	59
3	5	1	1	1		3			2	8
3	9		1		2					3
4	1	1	1							2
4	2	2		2		2				6
4	3					3				3
4	4	1	1	1		1			2	6
4	5	1	3	7	2	7		2	10	32
5	1				2				1	3
5	4				1					1
6	5					1				1
7	1	1	18	10	6	13	2		2	52
7	2				1					1
7	3		19	18	11	12	2		4	66
7	4		1	1	2	1		1		6
7	5		1			1			2	4
7	7				1					1
7	8					1				1
Total		81	98	88	47	92	10	90	119	625

V. faba despite being the most abundant type overall (32% of all isolates). Instead, this host showed a very strong preference for *nodDF*-2: 92% of *V. faba* isolates had *nodDF*-2, and 78% of all *nodDF*-2 isolates were from *V. faba*.

Combining 16–23S rDNA *ITS* and *nodDF* PCR-RFLP data, 34 combinations from a possible 63 (9 × 7) distinct PCR-RFLP patterns were found in the collection of 625 field isolates. In fact, considering only the RFLP types with frequencies above 2.5% (five each for *ITS* and *nodDF*), 24 of the expected 25 combinations were found. The only missing type was *ITS*-1 *nodDF*-2, which would be expected to occur 27 times based on the observed frequency of its constituent RFLP patterns. By contrast, the combination *ITS*-1 *nodDF*-1 occurred 86 times when only 34 would be expected, much of the excess being attributable to the very high frequency of this genotype in *V. cracca* nodules.

Although *V. faba* also showed a strong bias, it appears that in this case the selection was solely for the *nodDF*-2 symbiosis genotype, because *V. faba* harboured all the different *ITS* types in which this occurred.

Nineteen *nodDF* PCR products were sequenced, including representatives of each of the *Msp*I RFLP types. Because type *nodDF*-7 did not yield a PCR product with primers NBA12-NBF12', an internal fragment of *nodD* was sequenced from this type, and the phylogenetic tree in Fig. 1 is based on this part of the sequence. Strains of the same RFLP type cluster together as expected, and all sequences form a *R. leguminosarum* biovar *viciae* clade that is quite distinct from the sequences of other host specificities. Within this clade the *nodDF*-2 sequences cluster separately from the rest. The sequences from type *nodDF*-7, for which RFLP patterns could not be obtained, were all almost identical,

and were very close to those of types *nodDF*-3 to -6, suggesting that these strains were not a highly divergent lineage. On the other hand, they are clearly genetically distinct, as *nodDF*-3 occurs predominantly in the *ITS*-2 background and *nodDF*-4 in *ITS*-5, whereas *nodDF*-7 is rare in these chromosomal backgrounds but frequent in *ITS*-1 and *ITS*-3. A phylogenetic tree based on the sequence between *nodD* and *nodF* (not shown) is essentially similar to that for *nodD* except that the *nodDF*-4, -5 and -6 sequences cluster with *nodDF*-1 rather than with *nodDF*-3.

The main *nodDF* types (1, 2, 3), defined originally by *Msp*I restriction patterns, are supported strongly by the sequence data (Fig. 1). We have less evidence for the distinctness of the *ITS* types, although digestion with *Hae*III and *Alu*I of *ITS* PCR products from a subset of the strains did, in most cases, support the typing based on *Taq*I (data not shown). It remains formally possible that a given *ITS* type might arise more than once by independent mutation, so that a shared *ITS* pattern is not necessarily proof of common ancestry. Nevertheless, the associations between certain *nodDF* and *ITS* patterns are evidence that the *ITS* types do reflect significant genetic groups.

Relationship between genotype and host specificity

There was a clear relationship between *nodDF* genotype and the ability to nodulate *V. faba* (Table 3). Among the 80 strains tested for host range, 12 had the *nodDF*-2 genotype and all 12 nodulated *V. faba*. However, none of the 14 *nodDF*-1 strains could nodulate this host. For the other *nodDF* types tested, there was no clear pattern. *V. faba* was nodulated by 8/20 *nodDF*-3, 3/7 *nodDF*-4, 0/2 *nodDF*-5, 4/25 *nodDF*-7 strains. The failure of strains to nodulate or to fix nitrogen on the other host species was not related obviously to their *nodDF* type, but occurred sporadically in all genotypes.

L. aphaca and *L. nissolia* grow wild in southern England, but are not native to the study site. The range of genotypes

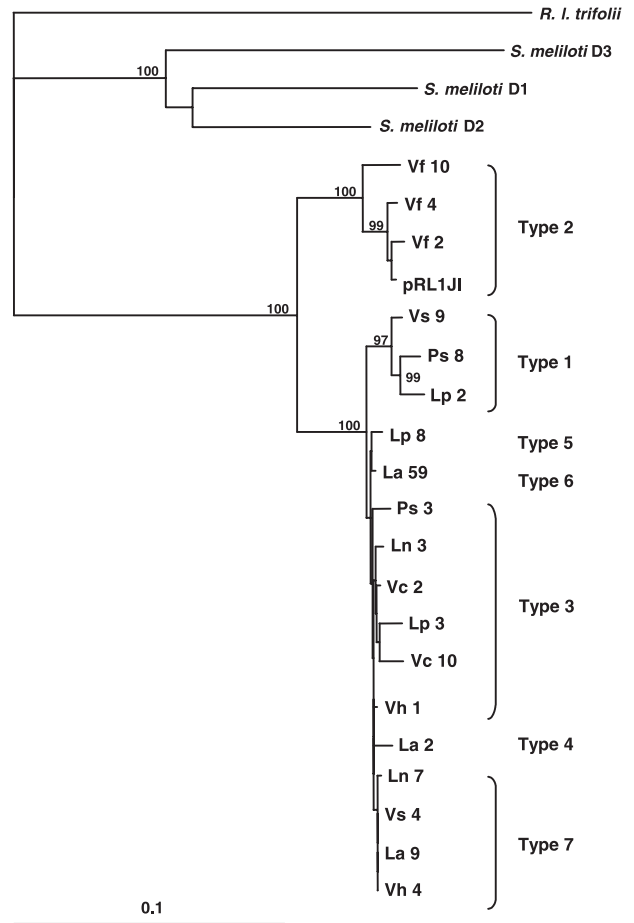

Fig. 1 Phylogeny based on nucleotides 52–800 of the *nodD* gene, using the neighbour-joining algorithm. Percentage bootstrap support (1000 iterations) is shown where this exceeds 70%, and the scale bar indicates substitutions per site. Sequences of the following species and strains were used: representatives of each *nodDF* PCR-RFLP type from field isolates (Accession nos AY226876–AY226890 and AY245528–AY245531); *Rhizobium leguminosarum* bv. *trifolii* ANU843 (X03721); *Sinorhizobium meliloti* 1021 (NC_003037); *R. leguminosarum* bv. *viciae* plasmid pRL1JI (Y00548).

Table 3 Genotypes and symbiotic phenotypes of 10 representative rhizobial isolates from each of eight host plant species. Column headings show host species of isolation (for names see Table 1). Each entry shows *ITS* and *nodDF* RFLP genotypes followed by nodulation phenotype on each of the legume species (except *L.a*) in order: 2 = Fix+ (pink nodules); 1 = Fix- (white nodules); 0 = Nod- (no nodules). The first column represents isolates Vc1 to Vc10, etc

Vc	Vh	Vs	Lp	La	Ln	Vf	Ps
1-1-2222002	2-3-2222202	2-3-2222202	3-7-2222212	1-7-1222222	2-3-2222222	4-2-2222222	5-4-2222202
2-3-2220002	3-1-2222202	2-3-2222202	4-1-2220202	3-4-2222202	3-1-1122202	6-2-2222222	2-2-2222222
4-3-2212002	3-7-2222200	2-3-2222202	3-3-2202101	3-1-0222202	2-3-1120201	6-2-2222221	4-3-2222222
3-2-2222022	1-7-2222202	3-7-0222202	3-7-2222202	1-7-1222202	3-7-1222201	5-2-2022220	3-7-2212202
1-1-2122202	3-7-2222202	5-4-2222222	3-7-2222102	5-3-1222222	3-1-2222200	3-2-2222221	4-4-2222202
5-3-2222121	3-7-2222200	1-7-2222202	1-5-2222202	1-7-0222222	3-1-2222202	3-2-2222222	2-3-2222202
1-1-2212002	2-3-2222222	4-3-2222222	5-4-1222222	4-3-2222222	3-7-2122201	4-2-2222222	5-7-2222202
1-1-2222102	3-7-2212201	5-4-0222202	1-5-2212202	1-7-1222202	1-7-1222200	6-2-2222222	1-1-2222202
2-3-2222002	1-7-2222202	3-1-2222202	3-7-2222202	3-7-1222202	1-7-2222220	2-2-2222222	1-1-1212202
1-3-2222002	4-3-2222200	2-4-2222222	2-3-2222222	3-7-0222202	1-1-1222201	4-2-2222221	3-7-2222202

found in their nodules was similar to that on the other wild species. All six of the *nodDF-7* strains tested from *L. aphaca*, and two of three from *L. nissolia*, formed ineffective or no nodules on *V. cracca*, which is consistent with the observation that *nodDF-7* was rarely isolated from *V. cracca*. However, most *nodDF-7* strains from other hosts were fully effective on *V. cracca*, so this is not a simple incompatibility between a particular *nodDF* genotype and a host species. There were insufficient seeds of *L. aphaca* to conduct host-range tests, but *L. nissolia* was generally poor in symbiosis with strains isolated from *V. cracca*. Indeed, only one strain (*ITS-1 nodDF-1*) was fully symbiotic, while the other strains, which had a range of genotypes, were unable to nodulate or, in two cases, nodulated without fixation.

To summarize these findings, the failure of certain strains to nodulate or fix nitrogen with particular hosts does not correlate clearly with the genetic markers, except that all 12 *nodDF-2* strains that were tested nodulated *V. faba* while none of the 14 *nodDF-1* strains did. Although this is a strong correlation, it does not demonstrate causation; indeed, in the full sample, four strains of the *nodDF-1* type were in fact isolated from *V. faba* nodules. Of course, the lack of other significant correlations need not mean that the other symbiotic differences do not have a genetic basis, because the *ITS* and *nodDF* markers that we used are only very small samples of the genome.

Discussion

Rhizobial diversity and host diversity

The first question we addressed was whether diversity of the rhizobial population was enhanced because each local host favoured a different subset of strains. There is little evidence for this. Despite the fact that eight different host species were used to isolate the rhizobia, the chromosomal variation identified in this study is low, considering collection size, compared with previous studies. Palmer & Young (2000) identified 25 distinct *HaeIII* RFLP patterns among 285 pea isolates from four UK sites, while Louvrier *et al.* (1996) identified 14 among only 37 *Rlv* isolates from soil at two French sites. *HaeIII* and *TaqI* have been shown to yield similar levels of resolution when comparing PCR-RFLP types of 16–23S *ITS* sequences (Laguerre *et al.* 1996), so the nine *TaqI* patterns that we found among 625 isolates are unexpectedly few. Of course, all our isolates were obtained from a single location, but the number of types is still lower than in comparable subsamples within the studies just cited. This low diversity in a wild population, compared to that found in cultivated fields, has been observed previously in *R. etli* (Souza *et al.* 1997).

Our isolates were not very diverse in their symbiosis genes, either, with only six *MspI* RFLP patterns, plus a class (*nodDF-7*) that did not yield PCR products with the primers.

Laguerre *et al.* (1996) and Louvrier *et al.* (1996), using the same primers, identified 10 distinct *MspI* RFLP patterns among 22 *Rlv* isolates from a single field site in France and seven distinct *HaeIII* restriction patterns among 113 *Rlv* isolates from soil at two French sites, respectively. Laguerre *et al.* (1996) showed that *HaeIII* was comparable in resolution to *MspI*.

Although we found that the overall diversity was modest, the wild legumes showed significant differences in their strain preferences (Table 2). The most distinctive symbiont population was found on *V. cracca*: 48% of isolates from this host had the genotype combination *ITS-1* and *nodDF-1*, whereas this type was found in only 10% of strains from the other local hosts (*V. hirsuta*, *V. sativa*, *L. pratensis*). Only one of 81 *V. cracca* isolates was *nodDF-7*, although this type made up 38% of isolates from other local hosts. Although, as these examples illustrate, there was some influence of host species, it remains true that most genotypes were obtained from most or all the host species, suggesting that specificity is generally low.

This conclusion was confirmed directly by the host-range testing of representative isolates (Table 1). Thirty of the 40 isolates from local host species (*V. cracca*, *V. hirsuta*, *V. sativa*, *L. pratensis*) formed an effective symbiosis on all four of the local hosts. A further six nodulated all hosts but failed to fix nitrogen on one of them, while the remaining four isolates nodulated only three of the four hosts.

Taken together, the genetic diversity and host range results certainly do not suggest that the diversity of host plants has led to an increased diversity of the rhizobia. With minor exceptions, the native host legumes appear to share a common pool of nonspecialist rhizobia. This suggests that, in this *Rlv*-Viciae community, there may not be strong linkage between below-ground (rhizobial) and above-ground (legume) diversity, although a rigorous test of this would require extensive measurements of the long-term survival of both partners. This linkage depends on the degree of preferential association shown by the partners and on differences in the benefits conferred by partners. Recent work has suggested that there may be a substantial linkage in the case of the arbuscular mycorrhizal association (van der Heijden *et al.* 1998a,b). This is ironic because, in contrast to rhizobia, the existence of strong host preferences in natural populations of arbuscular mycorrhizal fungi has been demonstrated only recently (Helgason *et al.* 2002; Vandenkoornhuyse *et al.* 2002, 2003).

The relationship between plant domestication and specificity

Modern experience indicates that the successful introduction of a legume crop to a new area may require deliberate inoculation to establish the appropriate rhizobial symbiont (Date 2001). It is possible that, in the past, rhizobia were

distributed unconsciously along with the crop. Alternatively, the crop might make use of the symbionts of indigenous wild legumes. In this case, there would be selection on the plants for less selectivity, so that globally successful crops would accept a broader range of rhizobia than their wild relatives. Our data do not provide support for this idea.

Far from having a broad specificity, broad bean (*V. faba*) proved to be the most specific of the legumes tested. Of the 90 isolates from this host, 83 were of the *nodDF-2* type, so that the diversity of symbionts on this host was much lower than for other legume species grown with the same soil population. The *nodDF-2* type appears to be a 'universal' symbiont, as it was also isolated (although in smaller numbers) from most of the other hosts, and 10 of the 12 *nodDF-2* strains that were tested formed an effective symbiosis on all the wild hosts (Table 3). The *nodDF-2* type is distinct from all the others in terms of its DNA sequence (Fig. 1), but the widely studied symbiosis genes of plasmid pRL1JI are of this type, as are those of *Rlv* strain 3841, whose genome is completely sequenced (http://www.sanger.ac.uk/Projects/R_leguminosarum/). The source strain of pRL1JI (*Rlv* strain 248) was isolated from a *V. faba* nodule, while 3841 was derived from a nodule on *P. sativum*, both in the United Kingdom. Strains of this symbiosis genotype made up about 16.5% of a sample of isolates from a pea crop in the United Kingdom (Young & Wexler 1988), and have been identified at a similar frequency (16%) in France (Laguerre *et al.* 1996).

It is interesting to compare our results with the findings of Laguerre *et al.* (2003), who isolated *Rlv* strains from French soils using *V. faba*, *P. sativum* and *V. sativa*. They found that *V. faba* isolates were predominantly of a *nodDF* type that they called g on the basis of its *HaeIII* restriction pattern. Laguerre *et al.* (2003) showed that *Rlv* strain 248 had type g, and that type g formed a group separate from the other common types in a dendrogram based on multiple restriction sites. For a subsample of 80 of our strains, we digested the *nodDF* PCR product with *HaeIII* and confirmed that this g pattern corresponds to our *MspI* type 2 which does, of course, form a separate clade and includes strain 248 (Fig. 1). It is striking that this *nod* genotype is selected preferentially by *V. faba* from soil populations in both France and the United Kingdom. However, isolates from *V. faba* in Jordan, which is close to the area of original domestication of the crop, had quite different *nodDF* types unlike anything in our UK sample (Mutch *et al.* 2003). Despite the very strong preference shown by *V. faba* in Europe, therefore, it seems that the *nodDF-2* type is possibly not the ancestral symbiont of *V. faba*.

Only a few *nodDF-2* strains were isolated from peas in our study; the majority of pea isolates (51%) were *nodDF-3*, which was completely absent from *V. faba* and formed only 26% of the nodules on the other host species. The

nodDF-3 pattern (based on an *MspI* digest) corresponds to the *HaeIII* pattern c of Laguerre *et al.* (2003), which was infrequent in their samples. (Our third common type, *nodDF-1*, corresponds to their pattern a.) *P. sativum* was more successful than *V. faba* in exploiting a range of rhizobial genotypes, but was nevertheless more restricted in its symbiosis than any of the wild legumes (Table 1). Differences in preference between pea and broad bean have been reported previously. Hynes & O'Connell (1990), who studied peas, broad beans and lentils (*Lens esculenta*), found a particular *Rlv* genotype that was common in peas but not identified in isolates from *V. faba* and *vice versa*. Other studies have also shown that *V. faba* and *P. sativum* select significantly for different *Rlv* genotypes (Evans *et al.* 1996; Laguerre *et al.* 2003). Our results confirm these observations, but suggest that such specificity might be more marked in crop legumes than in wild species.

Overall, it is clear that pea and broad bean share symbionts with wild legumes in the United Kingdom, but in our study they were able to exploit only some parts of the diverse rhizobial population that was available to the wild species.

Acknowledgements

We thank the Natural Environment Research Council for a research studentship (LAM) and funding under the EDGE initiative, and Allen Mould and Rosie Young for assistance with sequencing.

References

- Allen ON, Allen EK (1981) *The Leguminosae – a Source Book of Characteristics, Uses and Nodulation*. Macmillan Publishers Ltd, London.
- Beringer JE (1974) R factor transfer in *Rhizobium leguminosarum*. *Journal of General Microbiology*, **84**, 188–198.
- Bond DA (1976) Field bean (*Vicia faba*). In: *Evolution of Crop Plants* (ed. Simmonds NW), pp. 179–182. Longman and Hall, London.
- Date RA (2001) Advances in inoculant technology: a brief review. *Australian Journal of Experimental Agriculture*, **41**, 321–325.
- Davis EO, Evans IJ, Johnston AWB (1988) Identification of *nodX*, a gene that allows *Rhizobium leguminosarum* biovar *viciae* strain TOM to nodulate Afghanistan peas. *Molecular and General Genetics*, **212**, 531–535.
- Demezas DH, Reardon TB, Strain SR, Watson JM, Gibson AH (1995) Diversity and genetic structure of a natural population of *Rhizobium leguminosarum* bv. *trifolii* isolated from *Trifolium subterraneum* L. *Molecular Ecology*, **4**, 209–220.
- Evans J, Gregory A, Dobrowolski N, Morris SG, O'Connor GE, Wallace C (1996) Nodulation of field-grown *Pisum sativum* and *Vicia faba*: competitiveness of inoculant strains of *Rhizobium leguminosarum* bv. *viciae* determined by an indirect, competitive ELISA method. *Soil Biology and Biochemistry*, **28**, 247–255.
- Firmin JL, Wilson KE, Carlson RW, Davies AE, Downie JA (1993) Resistance to nodulation of cv. Afghanistan peas is overcome by *nodX*, which mediates an *O*-acetylation of the *Rhizobium*

- leguminosarum* lipo-oligosaccharide nodulation factor. *Molecular Microbiology*, **10**, 351–360.
- Geniaux E, Amarger N (1993) Diversity and stability of plasmid transfer in isolates from a single field population of *Rhizobium leguminosarum* bv *viciae*. *FEMS Microbiology and Ecology*, **102**, 251–260.
- Geurts R, Heidstra R, Hadri AE *et al.* (1997) Sym2 of pea is involved in a nodulation factor-perception mechanism that controls the infection process in the epidermis. *Plant Physiology*, **115**, 351–359.
- Handley BA, Hedges AJ, Beringer JE (1998) Importance of host plants for detecting the population diversity of *Rhizobium leguminosarum* biovar *viciae* in soil. *Soil Biology and Biochemistry*, **30**, 241–249.
- van der Heijden MGA, Boller T, Wiemken A, Sanders IR (1998a) Different arbuscular mycorrhizal fungal species are potential determinants of plant community structure. *Ecology*, **79**, 2082–2091.
- van der Heijden MGA, Klironomos JN, Ursic M *et al.* (1998b) Mycorrhizal fungal diversity determines plant biodiversity, ecosystem variability and productivity. *Nature*, **396B** 69–72.
- Helgason T, Merryweather JW, Denison J, Wilson P, Young JPW, Fitter AH (2002) Selectivity and functional diversity in arbuscular mycorrhizas of co-occurring fungi and plants from a temperate deciduous woodland. *Journal of Ecology*, **90**, 371–384.
- Howieson JG, O'Hara GW, Carr SJ (2000) Changing roles for legumes in Mediterranean agriculture: developments from an Australian perspective. *Field Crops Research*, **65**, 107–122.
- Hynes MF, O'Connell MP (1990) Host plant effect on competition among strains of *Rhizobium leguminosarum*. *Canadian Journal of Microbiology*, **36**, 864–869.
- Laguette G, Geniaux E, Mazurier SI, Casartelli RR, Amarger N (1993) Conformity and diversity among field isolates of *Rhizobium leguminosarum* bv. *viciae*, bv. *trifolii*, and bv. *phaseoli* revealed by DNA hybridization using chromosome and plasmid probes. *Canadian Journal of Microbiology*, **39**, 412–419.
- Laguette G, Louvrier P, Allard MR, Amarger N (2003) Compatibility of rhizobial genotypes within natural populations of *Rhizobium leguminosarum* biovar *viciae* for nodulation of host legumes. *Applied and Environmental Microbiology*, **69**, 2276–2283.
- Laguette G, Mavingui P, Allard MR *et al.* (1996) Typing of rhizobia by PCR DNA fingerprinting and PCR-restriction fragment length polymorphism analysis of chromosomal and symbiotic gene regions: application to *Rhizobium leguminosarum* and its different biovars. *Applied and Environmental Microbiology*, **62**, 2029–2036.
- Laguette G, Mazurier SI, Amarger N (1992) Plasmid profiles and restriction fragment length polymorphism of *Rhizobium leguminosarum* bv *viciae* in field populations. *FEMS Microbiology and Ecology*, **101**, 17–26.
- Lie TA, Gökten D, Engin M, Pijnenborg J, Anlarsal E (1987) Co-evolution of the legume–rhizobium association. *Plant and Soil*, **100**, 171–181.
- Lohrke SM, Orf JH, Sadowsky MJ (1996) Inheritance of host-controlled restriction of nodulation by *Bradyrhizobium japonicum* strain USDA 110. *Crop Science*, **36**, 1271–1277.
- Louvrier P, Laguette G, Amarger N (1996) Distribution of symbiotic genotypes in *Rhizobium leguminosarum* biovar *viciae* populations isolated directly from soils. *Applied and Environmental Microbiology*, **62**, 4202–4205.
- Mutch LA, Tamimi SM, Young JPW (2003) Genotypic characterisation of rhizobia nodulating *Vicia faba* from the soils of Jordan: a comparison with UK isolates. *Soil Biology and Biochemistry*, **35**, 709–714.
- O'Hara GW, Howieson JG, Graham PH (2003) Nitrogen fixation and agricultural practice. In: *Nitrogen Fixation in the Millennium* (ed. Leigh GJ), pp. 391–410. Elsevier Press, London.
- Palmer KM, Young JPW (2000) Higher diversity of *Rhizobium leguminosarum* biovar *viciae* populations in arable soils than in grass soils. *Applied and Environmental Microbiology*, **66**, 2445–2450.
- Schofield PR, Gibson AH, Dudman WF, Watson JM (1987) Evidence for genetic exchange and recombination of *Rhizobium* symbiotic plasmids in a soil population. *Applied and Environmental Microbiology*, **53**, 2942–2947.
- Silva C, Eguiarte L, Souza V (1999) Reticulated and epidemic population genetic structure of *Rhizobium etli* biovar *phaseoli* in a traditionally managed locality in Mexico. *Molecular Ecology*, **8**, 277–287.
- Somasegaren P, Hoben HJ (1994) *Handbook for Rhizobia: Methods in Legume–Rhizobium Technology*. Springer-Verlag, New York.
- Souza V, Bain J, Silva C *et al.* (1997) Ethnomicrobiology: do agricultural practices – and woman – modify the population structure of the nitrogen-fixing bacteria *Rhizobium etli*? *Journal of Ethnobiology*, **17**, 249–266.
- Souza V, Eguiarte LE (1997) Bacteria gone native vs. bacteria gone away? Plasmidic transfer and bacterial evolution. *Proceedings of the National Academy of Sciences USA*, **94**, 5501–5503.
- Sullivan JT, Patrick HN, Lowther WL, Scott DB, Ronson CW (1995) Nodulating strains of *Rhizobium loti* arise through chromosomal symbiotic gene transfer in the environment. *Proceedings of the National Academy of Sciences USA*, **92**, 8985–8989.
- Thompson JD, Gibson TJ, Plewniak F, Jeanmougin F, Higgins DG (1997) The CLUSTAL_X windows interface: flexible strategies for multiple sequence alignment aided by quality analysis tools. *Nucleic Acids Research*, **25**, 4876–4882.
- Vandenkoornhuysse P, Husband R, Daniell TJ *et al.* (2002) Arbuscular mycorrhizal community composition associated with two plant species in a grassland ecosystem. *Molecular Ecology*, **11**, 1555–1564.
- Vandenkoornhuysse P, Ridgway KP, Watson IJ, Fitter AH, Young JPW (2003) Co-existing grass species have distinctive arbuscular mycorrhizal communities. *Molecular Ecology*, **12**, 3085–3095.
- Wang CL, Beringer JE, Hirsch PR (1986) Host plant effects on hybrids of *Rhizobium leguminosarum* biovar *viciae* and *trifolii*. *Journal of General Microbiology*, **132**, 2063–2070.
- Wernegreen JJ, Harding EE, Riley MA (1997) *Rhizobium* gone native: unexpected plasmid stability of indigenous *Rhizobium leguminosarum*. *Proceedings of the National Academy of Sciences USA*, **94**, 5483–5488.
- Young JPW (1985) *Rhizobium* population genetics – enzyme polymorphism in isolates from peas, clover, beans and lucerne grown at the same site. *Journal of General Microbiology*, **131**, 2399–2408.
- Young JPW, Demetriou L, Apte RG (1987) *Rhizobium* population genetics: enzyme polymorphism in *Rhizobium leguminosarum* from plants and soil in a pea crop. *Applied and Environmental Microbiology*, **53**, 397–402.
- Young JPW, Johnston AWB, Brewin NJ (1982) A search for peas (*Pisum sativum* L.) showing strain specificity for symbiotic *Rhizobium leguminosarum*. *Heredity*, **48**, 197–201.

- Young JPW, Matthews P (1982) A distinct class of peas (*Pisum sativum* L.) from Afghanistan that show strain specificity for symbiotic rhizobium. *Heredity*, **48**, 203–210.
- Young JPW, Wexler M (1988) Sym plasmid and chromosomal genotypes are correlated in field populations of *Rhizobium leguminosarum*. *Journal of General Microbiology*, **134**, 2731–2739.
- Zézé A, Mutch LA, Young JPW (2001) Direct amplification of *nodD* from community DNA reveals the genetic diversity of *Rhizobium leguminosarum* in soil. *Environmental Microbiology*, **3**, 363–370.

Lesley Mutch is currently a postdoctoral scientist studying competition and diversity of rhizobia at Murdoch University. Most of the work presented here formed part of her PhD thesis at the University of York. Peter Young is Professor of Molecular Ecology, and his main research interests are in the genome evolution, diversity and host specificity of rhizobia and of arbuscular mycorrhizal fungi.
