



UNIVERSITY OF LEEDS

This is a repository copy of *Simulation of the deformable lateral boundaries in biaxial test using DEM*.

White Rose Research Online URL for this paper:

<https://eprints.whiterose.ac.uk/205272/>

Version: Accepted Version

Article:

Momeni, A., Clarke, B., Sheng, Y. et al. (1 more author) (2024) Simulation of the deformable lateral boundaries in biaxial test using DEM. *Particuology*, 88. pp. 161-175. ISSN 1674-2001

<https://doi.org/10.1016/j.partic.2023.08.015>

© 2023 Chinese Society of Particuology and Institute of Process Engineering, Chinese Academy of Sciences. Published by Elsevier B.V. All rights reserved. This manuscript version is made available under the CC-BY-NC-ND 4.0 license <http://creativecommons.org/licenses/by-nc-nd/4.0/>.

Reuse

This article is distributed under the terms of the Creative Commons Attribution-NonCommercial-NoDerivs (CC BY-NC-ND) licence. This licence only allows you to download this work and share it with others as long as you credit the authors, but you can't change the article in any way or use it commercially. More information and the full terms of the licence here: <https://creativecommons.org/licenses/>

Takedown

If you consider content in White Rose Research Online to be in breach of UK law, please notify us by emailing eprints@whiterose.ac.uk including the URL of the record and the reason for the withdrawal request.



eprints@whiterose.ac.uk
<https://eprints.whiterose.ac.uk/>

Simulation of the deformable lateral boundaries in biaxial test using DEM

Ali Momeni^{1,2}, Barry Clarke³, Yong Sheng⁴ and Ali Hassapour^{5*}

1. WSP, 3 Wellington Pl, Leeds LS1 4AP, UK; Ali.Momeni@WSP.com
2. Visiting Academic at Hull University, Hull, HU6 7RX, UK, A.Momeni@hull.ac.uk
3. School of School of Civil Engineering, Leeds LS2 9JT, UK
B.G.Clarke@leeds.ac.uk
4. School of Computer Science, University of Hull, Hull, HU6 7RX, UK
y.sheng@hull.ac.uk
5. School of Chemical and Process Engineering, University of Leeds, Leeds LS2 9JT, UK,
A.Hassanpour@leeds.ac.uk

* Corresponding author: A.Hassanpour@leeds.ac.uk; Tel.: 01133432405

Abstract

The use of the discrete element method (DEM) to study soil mechanics' problems at particle level opens a new window to enhance our understanding of the mechanical behaviour of soil. This method can provide abundant information at the particle-scale and can be used as a powerful tool to illustrate the macro-mechanical behaviour of soils based on the inter-particle mechanisms. The triaxial test is one of the most common laboratory methods to study the macro-mechanical behaviour of particulate materials such as soil. However, many problems in geotechnical design can be assumed and simplified as a plane strain problem. Therefore a biaxial test can be conducted to reproduce the macro-mechanical behaviour of soil, where the sample is enclosed by two horizontal rigid platens and a vertical latex membrane, which is a deformable continuous element and allowing the enclosed specimen to deform freely while maintaining confining stress during loading. This paper presents an algorithm to represent physical and mechanical characteristics of latex membrane in the 2D DEM simulation of biaxial test using the PFC^{2D} code. To investigate the impact of the lateral boundary conditions on micro-macro mechanical behaviour of soil samples, two sets of DEM biaxial tests are considered with rigid and deformable lateral boundary conditions. The DEM modeling results indicate that the lateral boundary conditions have a significant effect on the micro-scale fabric properties, thickness and inclination of the shear band. The comparison between these two simulations also demonstrates that the lateral boundary conditions play a major role in the peak and post-peak stress-strain behaviour as well as the dilation and critical state behaviour of granular soils.

Keywords: Discrete Element Method, Biaxial test, Deformable boundaries, Shear band, Critical state, Fabric Anisotropy, Geometrical Stability Index

1. Introduction

The triaxial test is the most common laboratory method applied on the soil element to determine stress strain characteristics [1, 2]. This information is produced by monitoring the imposed displacement and pressure over the boundaries of the sample. Many problems in geotechnical design, however, are

1 assumed to be plane strain [3, 4]. That is, studying the soil behaviour through two-dimensional
2 laboratory tests such as biaxial test can be more appropriate. In a biaxial test, the granular soil is
3 bounded with four boundaries: two horizontal rigid platens and two vertical membranes which allow
4 the particulate system to deform freely during shearing, while maintaining a specified confining
5 condition. However, applying such laboratory test on the granular soil is not fully addressed in the
6 literature. Alternatively, a two-dimensional simulation, for instance using Discrete Element Method
7 (DEM), can be applied to analyse this test. Since the response of granular soils, such as stress and strain
8 to the applied load in this test is only measured over the boundaries of sample, simulating the proper
9 boundary condition using DEM plays a major role in the macro mechanical behaviour of particulate
10 system during testing. The use of DEM to simulate and analyse the problems in the geomechanics field
11 has been increasing [5, 6, 7]. It has been proven that DEM is a powerful numerical tool to study the
12 micro and macro scales of granular soils by providing abundant information at the particle scale such
13 as inter-particle interactions, particle velocities, displacements and rotations that might not be
14 measured in the laboratory tests. Many researchers, the most notable [8, 9, 10], have illustrated that an
15 invaluable insight can be attained from considering two-dimensional models of idealized soil. A series
16 of DEM biaxial tests on intact rock with rigid boundary condition were performed for comparison and
17 calibration purposes with standard triaxial test data from the laboratory [11, 12]. The most notable
18 DEM biaxial test on idealized soil with edge bounded particles were implemented by Oda et. al [13]
19 and Kawamoto et. al [14]. This method can result in developing the bending stiffness which has an
20 impact on the bulk responses of the particulate systems. Additionally, the boundary particles cannot
21 freely move during loading. Chung and O'Sullivan [41] have introduced an algorithm to simulate
22 deformable boundaries. In their work, boundary particles are able to move, while limited by a confining
23 pressure. In this paper, we have made some improvements in the algorithm to model the continuous
24 membrane for lateral boundaries of biaxial test as deformable boundaries [15]. The modified algorithm,
25 which is described in detail in section 6 of this paper, is used to investigate the sensitivity of the macro-
26 mechanical behaviour of soil as well as the fabric evolution to the lateral boundary conditions: rigid
27 boundaries and deformable boundaries.

28 2. DEM implementation in PFC^{2D}

29 DEM is an advanced numerical algorithm which was originally proposed by Cundall and Strack [5]. It
30 can dynamically simulate and track the micro-macro scale behaviour of granular materials. The main
31 advantage of this method is the generation of abundant information at the particle scale, which can be
32 used to comprehend the physics of granular systems. This method is proven to be a comprehensive
33 method to study granular soils [16, 17, 18, 19, 20, 21, 22, 23, 24]. The framework of this method is based
34 on both contact law and motion equation. Contact model is applied to compute contact forces including
35 normal and shear form from imposed contact deformations through the normal and shear contact
36 stiffnesses, while motion equation is used to calculate the particle movement. In this paper, the DEM
37 simulations are implemented using the software PFC^{2D} 4.1.

38 2.1. Contact law

39 The contact force (F_i) applied on a disk particle in PFC^{2D} code is decomposed into normal force (F_i^n)
40 and tangential force (F_i^s). The former is directed along the tangent to the particle and the latter is
41 directed toward the particle center.

$$42 F_i = F_i^n + F_i^s \quad (1)$$

43 To preserve the geometry of particles during loading, it is assumed in PFC^{2D} that particles are rigid with
soft contact, which means that a contact overlap between two particles (e.g., a and b) is applied rather

1 than a contact deformation. The magnitude of this overlap is computed by a contact law. In the present
 2 study, a linear elastic contact law is applied to calculate the components of contact forces. The normal
 3 and tangential displacements at time step Δ_t is calculated as follows:

$$\Delta_n = [(\dot{x}^b - \dot{x}^a)] \mathbf{n} \Delta_t \quad (2)$$

$$\Delta_s = \{[(\dot{x}^b - \dot{x}^a)]\mathbf{t} - (\dot{\theta}^a|R^a| + \dot{\theta}^b R^b)\}\Delta_t$$

4 where \dot{x}^a , \dot{x}^b , $\dot{\theta}^a$ and $\dot{\theta}^b$ are translational and rotational particle velocities of particle a and b,
 5 respectively. R^a and R^b are the particle radius. \mathbf{n} and \mathbf{t} are the normal and tangential unit vector of.

6 To calculate inter-particle normal force, contact models including linear elastic or Hertzian [25] can be
 7 used. In the present study, a linear elastic model is applied. The magnitude of the normal and tangential
 8 contact forces is calculated via:

$$(\mathbf{F}_i^n)_t = (\mathbf{F}_i^n)_{t-1} + (\Delta \mathbf{F}_i^n)_t \quad \text{where } \Delta \mathbf{F}_i^n = K_n(\Delta_n)_t \quad (3)$$

$$(\mathbf{F}_i^s)_t = (\mathbf{F}_i^s)_{t-1} + (\Delta \mathbf{F}_i^s)_t < \mu(\mathbf{F}_i^n)_t \quad \text{where } \Delta \mathbf{F}_i^s = K_s(\Delta_s)_t \quad (4)$$

9 The total contact shear force is compared to the Coulomb sliding friction or sliding capacity criterion
 10 (i.e. $\mu(\mathbf{F}_i^n)_t$) to check whether sliding has occurred. When the resultant force and torque in the z-
 11 direction (calculated by multiplying tangential contact force by the distance from the particle center to
 12 the contact location) are computed for each particle, the local damping force \mathbf{F}_i^d will be added to them:

$$\mathbf{F} = \sum [(\mathbf{F}_i^n)_t \mathbf{n} + (\mathbf{F}_i^s)_t \mathbf{t}] + \mathbf{F}_i^d$$

$$\mathbf{M} = \left[\mathbf{R} \sum [(\mathbf{F}_i^s)_t \mathbf{t}] + \mathbf{F}_i^d \right] \quad (5)$$

$$\mathbf{F}_i^d = -\alpha |\mathbf{F}| \text{sign}(\dot{x}); \quad \text{sign}(v) = \begin{cases} +1, & \text{if } \dot{x} > 0 \\ -1, & \text{if } \dot{x} < 0 \\ 0, & \text{if } \dot{x} = 0 \end{cases}$$

13 where α , $|\mathbf{F}|$ and \dot{x} are damping constant, resultant force on the particle and particle velocity,
 14 respectively. The computed resultant force and torque acting on the particle is used to determine the
 15 change in particle velocity via Newton's second law for the next time step.

16 3. Soil Fabric

17 In granular mechanics, soil fabric refers to the size, shape and arrangement of soil particles. Fabric
 18 quantities include either particle orientation, if 2D disk particles are used, or contact orientation and
 19 branch vector orientation for non-circular particles. These fabric quantities are often presented as an
 20 average or graphically (e.g. polar diagram of contacts). Rothenburg et al. [26] proposed a closed form
 21 solution to estimate the polar diagram of contacts.

$$E(\theta) = \frac{1}{2\pi} [1 + a \cos 2(\theta - \theta_a)] \quad (6)$$

22 where a represents "fabric anisotropy" in a granular system, depending on the number and density of
 23 unit normal vectors in principles axes. Note, Equation (6) should be drawn in polar coordinates. The
 24 shape of $E(\theta)$'s function is circular in polar coordinates and $E(\theta)$ represents mathematically the radius
 25 of the polar diagram distribution of normal contacts at each θ value. The variable θ , which is measured

1 clockwise, varies between 0° and 360°). Figure 1 schematically illustrates the concept of $E(\theta)$ and θ . a
 2 represents the deviation between the geometry of contact distribution and the isotropic contact
 3 distribution. For example, if $a = 0$, $E(\theta)$ will be a circle such that the state of the system being
 4 considered is in an isotropic state. θ_a is the direction of anisotropy. Parameters, a and θ_a , are obtained
 5 by the following equations:

$$a = \frac{2 \sin \Delta\theta}{N \Delta\theta} \sqrt{[\sum_{g=1}^{n_g} N_g \sin((2g-1)\Delta\theta)]^2 + [\sum_{g=1}^{n_g} N_g \cos((2g-1)\Delta\theta)]^2} \quad (7)$$

$$\theta_a = \frac{1}{2} \tan^{-1} \frac{\sum_{g=1}^{n_g} N_g \sin((2g-1)\Delta\theta)}{\sum_{g=1}^{n_g} N_g \cos((2g-1)\Delta\theta)} \quad (8)$$

6 where N is the total number of contacts, $\Delta\theta = \frac{360}{n_g}$, n_g the number of segments and N_g is the number of
 7 contacts within the g^{th} segment. Figure 1 schematically presents the concept of segment, n_g , highlighted
 8 in Equation 7 and Equation 8.

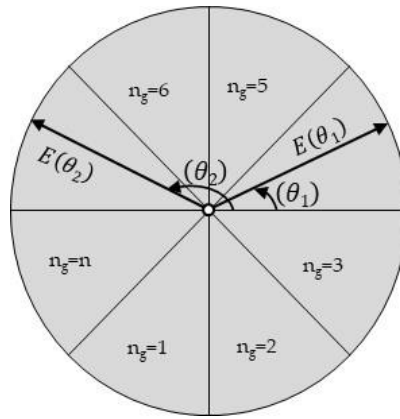

9
 10 **Figure 1** Schematically presentation of the concept of $E(\theta)$, θ , segment, n_g highlighted in Equation 6 to Equation 8

11 In fact, fabric anisotropy parameter shows the ability of granular systems to create the anisotropy state
 12 in normal contact distribution. Rothenburg [27] applied a similar idea to estimate an analytical form of
 13 polar diagram for normal contact force distribution, $\bar{f}_n^c(\theta)$, of an idealised 2D particulate system during
 14 loading:

$$15 \quad \bar{f}_n^c(\theta) = \bar{f}_0^c [1 + a_n \cos 2(\theta - \theta_n)] \quad (9)$$

16 where a_n is the normal contact force anisotropy. Note, similar to Equation (6) the above Equation should
 17 be drawn in polar coordinates. θ_n is a direction of $\bar{f}_n^c(\theta)$. The similar approach applied to specify a_n
 18 and θ_n :

$$19 \quad \bar{f}_0^c = \frac{1}{2\pi} \sum_{g=1}^{n_g} f_n^c(g) \Delta\theta \quad (10)$$

$$f_n^c(g) = \sum_{i=1}^{nc_g} f_n^{c_i}$$

$$a_n \sin 2\theta_n = \frac{1}{\pi \bar{f}_0^c} \sum_{g=1}^{n_g} f_n^c(g) \sin((2g-1)\Delta\theta)\Delta\theta$$

$$a_n \cos 2\theta_n = \frac{1}{\pi \bar{f}_0^c} \sum_{g=1}^{n_g} f_n^c(g) \cos((2g-1)\Delta\theta)\Delta\theta$$

1 where nc_g and $f_n^{c_i}$ are the number of contacts within g^{th} segment and the normal contact force of i^{th}
 2 contact from g^{th} segment respectively. If $a_n = 0$, $\bar{f}_n^c(\theta) = \bar{f}_0^c$. That is, the system is likely to be isotropic
 3 [22]. One of the key microscopic parameters, which are defined at particle-level, is the average
 4 coordination number which increases with densification [28, 29]. This parameter is the average number
 5 of contacts per particle within a specific volume of a particulate assembly and consequently it provides
 6 a measure of packing density or packing intensity of fabric at particle-level. For a volume of particulate
 7 assembly with N_p particles and total number of contacts, N_c , the definition of average coordination
 8 number C_n is given by:

$$C_n = \frac{2N_c}{N_p} \quad (11)$$

9 Since each contact is shared between two particles, the actual number of contacts is multiplied by 2.
 10 Rothenburg and Kruyt [30] and Maeda [31] have shown that average coordination number should be
 11 at least three for idealized disk particle when a granular system is in quasi-static equilibrium.

12 4. Geometrical stability index

13 The fabric quantities illustrated above are average quantities for a volume of particles. For instance, the
 14 average coordination number provides an average measure of bulk packing density. However, this
 15 average fabric quantity cannot demonstrate how contacts are distributed around a particle. This issue
 16 was considered in average normal contact distribution which statistically describes the orientation of
 17 contacts during loading. These collective fabric terms can be used to interpret the bulk stability of a
 18 granular system and give an indication of the response and bulk instability [9, 28]. However, instability
 19 occurs at a particle level which may progress causing local instability. Geometrical stability index, λ , is
 20 a state-of-the-art fabric term which can measure the contact deviation of each particle from the
 21 arrangement of the most stable contacts during loading [32]. In this concept, a set of n-stable contact
 22 arrangements is defined for each particle which is in contact with n particles. The radial distance
 23 between two contacts on the perimeter of a particle is the minimal angle between them. The deviation
 24 of the contact arrangement of a particle, d^{sn} , from a geometrical stable contacts arrangement is
 25 expressed as the sum of the deviation of each contact point, $d(S_i^n)$, from the associated stable location
 26 such that:

$$d^{sn} = \sum_{i=1}^n d(S_i^n) \quad (12)$$

27 This is repeated for each contact. The minimum value of d^{sn} is D :

$$D = \min\{d^{sn}\} \quad (13)$$

28 To make it dimensionless, it is divided by 360° .

$$\lambda = \frac{D_M}{360} \quad (14)$$

1 in which λ is geometrical stability index.

2 Error! Reference source not found.a shows particle, D, is contact with three particles, A, B and C. A set
 3 of 3-stable contact arrangements is defined for this contact arrangement as shown in Error! Reference
 4 source not found.b–d. If the angle between particle A and particle B is 120° and the angle between
 5 particle B and particle C is 120° , there is geometric stability. If either of these angles $\neq 120^\circ$ then the
 6 configuration is no longer geometrically stable. This is expressed in terms of the deviation of the lines
 7 connecting the centers of the particles from the geometrically stable configuration. The dash lines in
 8 each of these figures is the stable contact configuration, when the angle between them is 120° .

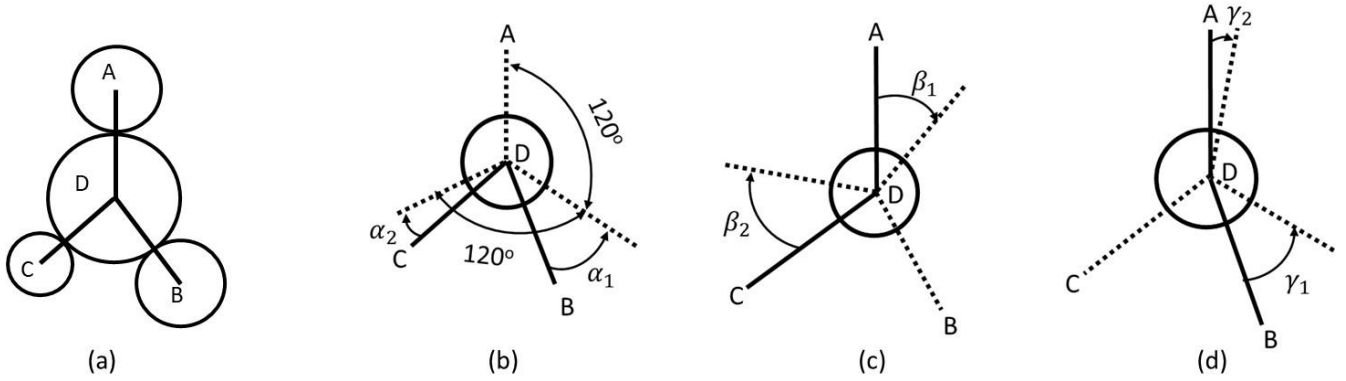

9

10 Figure 2 Concept of geometrical stability index (After Momeni et al. 2022 [1])Therefore, there are three
 11 sets of d^{Sn} . For the first set (Figure 2b):

$$d^{Sn^A} = \alpha_1 + \alpha_2 \quad (15)$$

12 For the second set (Figure 2c)

$$d^{Sn^B} = \beta_1 + \beta_2 \quad (16)$$

13 For the third set (Figure 2d):

$$d^{Sn^C} = \gamma_1 + \gamma_2 \quad (17)$$

14 Thus, the geometrical stability index for this particle is:

$$\lambda_2 = \frac{\min \{d^{Sn^A}, d^{Sn^B}, d^{Sn^C}\}}{360} \quad (18)$$

15 It is assumed that particles with one or no contact are not stable and are assigned a value of λ of one.

16 Reader to refer to Momeni et. al [32] for more details of this state-of-the-art fabric term.

17 5. Boundary conditions in DEM biaxial test overview

18 In this paper, two-dimensional biaxial specimens consisting of 2D idealized disk particles are used to
 19 qualitatively investigate the sensitivity of the micro-macro mechanical behaviour of idealized granular
 20 sand to the side boundary conditions: rigid boundary and deformable boundary. Particles are initially
 21 generated within a chamber enclosed with four rigid boundaries then isotropically consolidated to the
 22 target confining pressure. As biaxial specimen is sheared, the confining stress along the side boundaries
 23 is maintained at a constant value in combination with a servo-controlled system to control the stress. A
 24 servo-control mechanism together with boundary conditions are required to be employed in DEM
 25 biaxial tests to maintain the hydrostatic confining pressure during application of the deviatoric load.

1 The servo-control is used at the side boundaries of the sample. A rigid boundary is usually employed
2 by DEM analysts [32, 33, 34]. In this approach, a specific velocity is given to the rigid boundary through
3 the servo-control to maintain the target confining pressure. However, the true fabric evolution and bulk
4 deformation of sample cannot be developed as the rigid boundaries inhabit the free movement of
5 boundary particles. Additionally, the magnitude of contact forces developed between those particles
6 that are in contact with the rigid boundary are high. This results in significant changes in the macro
7 stress distribution over the boundary. Using an inflexible boundary takes longer for the particulate sand
8 system to reach the critical behaviour. As stated by Momeni [32] the elastic parameters including
9 Young's modulus and Poisson's ratio attained from inflexible boundary can be reliable. To show a true
10 bulk deformation (e.g. bulge deformation and true shear band) and fabric evolution a deformable
11 boundary should however be employed. Similar to continuum model where boundary conditions can
12 be either displacement or force control over the nodes of boundary elements, the boundary condition
13 in a DEM simulation can be expressed by either displacement or force control over the boundary
14 particles. The concept of displacement boundary condition is to maintain the confining stress over each
15 boundary particle, in two directions, σ_x and σ_y , to a target stress value by adjusting the velocity of each
16 boundary particle in two directions, $\dot{\mathbf{u}}_x$ and $\dot{\mathbf{u}}_y$, within a biaxial sample. At the start of each time step,
17 the value of the boundary particle stresses within the biaxial chamber in two directions, σ_x and σ_y , is
18 calculated by DEM solver (e.g. PFC^{2D}) and compared with the target confining stress, σ_t . If the boundary
19 particle stresses are equal to σ_t , the particle velocity, $\dot{\mathbf{u}}_x$ and $\dot{\mathbf{u}}_y$, will be set to zero; otherwise the particle
20 velocity might be adjusted through the following relation:

$$\dot{\mathbf{u}}_x = G_x(\sigma_x - \sigma_t) \quad \text{where} \quad G_x \leq \frac{\beta A_x}{K_n \Delta t} \quad (19)$$

$$\dot{\mathbf{u}}_y = G_y(\sigma_y - \sigma_t) \quad \text{where} \quad G_y \leq \frac{\beta A_y}{K_n \Delta t}$$

21 where G_x , G_y , A_x , A_y , β , K_n and Δt are the gain parameter, projection area of particle in x and y directions,
22 a constant value between 1 and 0.01, normal contact stiffness and time step. The projection area of
23 particle in x and y directions will be explained in Section 6.1. A change in the displacement value given
24 to a boundary particle leads to a change in its deformation value with neighboring particles. This
25 alteration in the contact deformation of a boundary particle results in a change in its contact force value
26 and stress value. For stability, the absolute value of the change in particle stresses must be less than the
27 absolute value of the difference between the measured and target stresses. This prevents overshooting
28 of the target stress, which would lead to an oscillation about the target stress that would grow in an
29 unbounded fashion and lead to numerical instability.

30 In the force boundary condition, an external force equal to the target confining stress applied to the
31 boundary particles at each time step to maintain the target confining stress. However, using force
32 boundary conditions is more efficient since in displacement boundary conditions at each time step the
33 stress tensor of each boundary particle should be calculated and compared with target confining stress.
34 Periodic boundary is also used by DEM analysts to simulate the boundary of DEM models [35, 36]. In
35 this approach, the particulate element is virtually extended in all directions by repeating this element.
36 Additionally, either displacement or force boundary conditions should be coupled over the periodic
37 boundary particles to maintain the target confining stress during the biaxial test. The use of periodic
38 boundaries has the following effect on the physics of the DEM model. When a particle flies over the
39 periodic boundary, a new particle with the same properties enters the system from the adjacent virtual
40 system on the opposite side. When this boundary condition is applied, the expansion and localization
41 of the model during loading cannot be take place because the dimension of periodic space is already set
42 to a constant value. When the system expands, the displacement of boundary particles may exceed the
43 set periodic space. At this stage, those boundary particles will be removed automatically, and the same

1 particle enters the system from the adjacent virtual system on the opposite side. This leads to change in
2 the normal shear force distribution on the boundary. However, any unexpected changes in boundary
3 particles result in change in the average un-balanced force system. That means the significant and
4 permanent chaos in un-balanced forces and particle velocities will be take place. Thus, the magnitude
5 of deviatoric load should be small enough to prevent boundary particles passing the periodic boundary.
6 El Shamy and Denissen [37] applied periodic boundary to investigate liquefaction phenomena using
7 DEM simulations. Zamani and El Shamy [38] studied earthquake seismic wave propagation through
8 the dry granular soil using PFC^{3D} [39] qualitatively. The periodic boundary condition was used for this
9 work.

10 6. The history of simulating membrane latex in DEM

11 The role of latex in triaxial test is to prevent the pressurized fluid getting into the sample, allowing the
12 system to naturally deform during loading. To simulate this in DEM, those particles that are in contact
13 with latex in the real triaxial text should be identified through the given algorithm. These boundary
14 particles should also behave similarly to the latex membrane in a real physical test. Two algorithms are
15 generally applied to identify the boundary particles by DEM analysts. In both algorithms the sample
16 enclosed with rigid boundaries is firstly isotropically consolidated. People including [8, 9, 10, 13, 40]
17 first identified those particles are in contact with rigid side boundaries. They then applied a contact
18 bond with a high tensile capacity between the boundary particles. The boundary particles in this
19 method cannot be updated as the boundary particles are bonded initially. Additionally, the magnitude
20 of the contact bond should be high enough to not fail during bulk expansion. As the moment stiffness
21 of latex applied in triaxial tests is ignorable, bonding the lateral boundary particles generates larger
22 moment stiffness than recommendable to model experiments properly. Therefore, boundary particles
23 cannot freely move during loading. This difficulty was sorted out partially in the work carried out by
24 Cheung and O'Sullivan [41] who developed an algorithm written by FISH language programming to
25 simulate a lateral membrane boundary for biaxial test using PFC^{2D}. They applied force control boundary
26 conditions to maintain the confining stress along the boundary particles. In this approach, frictionless
27 membrane particles can deform freely during testing without bounding them, while maintaining a
28 specified stress condition. O'Donovan et al. [42] applied this algorithm to maintain confining pressure
29 over the lateral boundaries in order to study two-dimensional seismic S-waves propagation within an
30 idealized frictional uniformly-radius sized disks 0.0029 [m] in a hexagonal packing using a series of
31 PFC^{2D} simulations. At large deformation where the biaxial specimen starts to bulge or a shear band
32 traverses the sample, a number of particles that have been already part of membrane boundary particles
33 may separate from the biaxial sample by losing their contact with other particles within the sample.
34 Based on this algorithm, those particles that have been separated from the specimen and flown over the
35 boundary are identified by only comparing the x-coordinate of each particle centroid within the
36 specimen with the minimum centroidal x-coordinate of the boundary particles. As the membrane
37 boundary deforms during loading, both y- and x-coordinates of separating particles need to be
38 considered to identify escaping particles from boundary. This will help to insert these particles to an
39 appropriate position at the boundary, which was not clear from the work of Cheung and O'Sullivan
40 [41] and O'Donovan et al. [42]. In the current paper we introduce a slightly modified algorithm to
41 simulate the continuous latex membrane for biaxial test simulation using PFC^{2D}. This algorithm is
42 described in detail below.

43 6.1. Deformable lateral boundary

44 This section will explain the algorithm to produce deformable lateral boundaries. When the two-
45 dimensional granular system enclosed with four rigid boundaries is isotropically consolidated, the two
46 lateral boundaries are removed and two deformable membrane lateral boundaries are applied to

1 maintain the lateral confining stress. For this purpose, comprehensive subroutines using PFC^{2D} and fish
 2 language programming [15] were developed to derive the pathway of deformable boundary particles.
 3 The stages of this algorithm which is based on directed graph theory is as follows:

4 1. Introduce two separate ranges for the left- and right-hand sides of the sample to recognize the
 5 boundary particles (see **Figure 3(a)**). The boundary particles should form two continuous chains at the
 6 edge of the model. This means that the centroid of particle (i) is above the centroid of particle ($i - 1$) and
 7 below the centroid of particle ($i + 1$). However, this is not always the case as shown in **Figure 3(b)** where
 8 some particles at the edge of the model are not part of the chain, i.e. while particles in **Figure 3b**. This
 9 means that the deformable boundary lies within a boundary zone. Trial and error study showed that
 10 the zone was ten times the mean particle size.

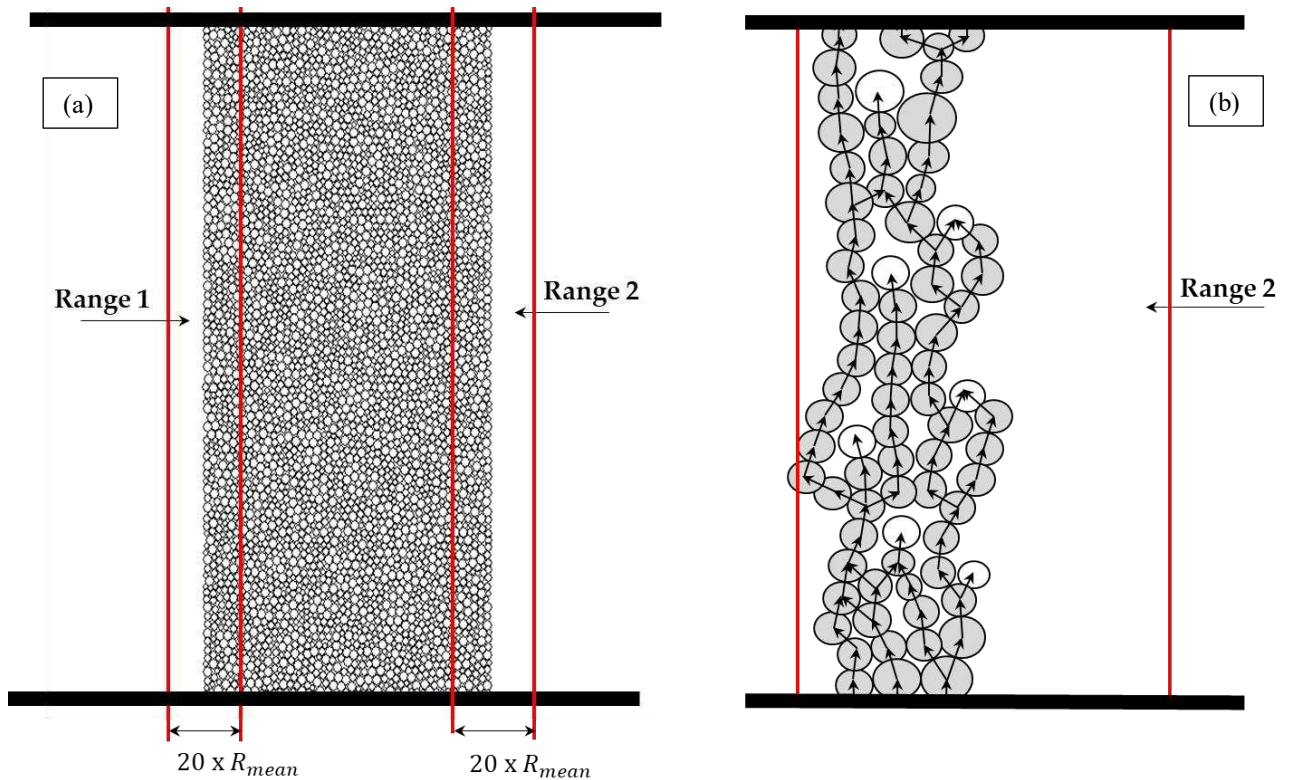

11
 12 Figure 3 (a) Define two separate ranges for left- and right-hand side of the sample. (b) Finding the degenerate
 13 particles on left boundary schematically

14 2. Two-dimensional arrays are then defined to store all the particles' addresses within the ranges
 15 stated in stage 1. The first component of array is to store the particles' identification (i.e. particle number
 16 and the second component of array is to assign an index "1" or "0" to all these particles, executed in the
 17 next stage.

18 3. A loop upon all particles stored in arrays, defined in stage two, are executed and the index of
 19 the particles are assigned to "1" and "0" for particles that are in contact with their immediate above and
 20 those that are not in contact with their immediate above particle, respectively. These are shown in
 21 **Figure 4a** (gray and white particles assigned with the index of 1 and 0, respectively).

22 4. Next, the loop will be continued to find the degenerate directed graphs (white pathway in
 23 **Figure 4(a)**) and continuous directed graphs (light gray pathways in **Figure 4(a)**).

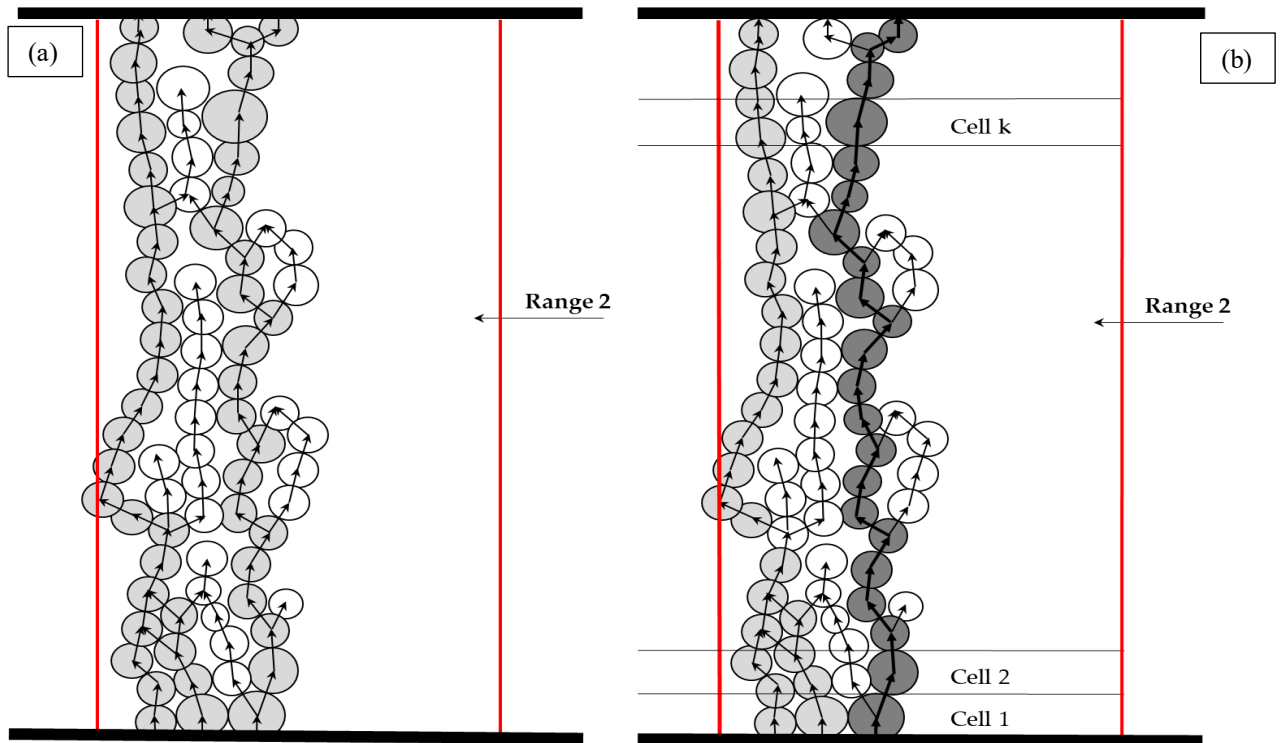

1

2 Figure 4 (a) Determination of all degenerate particles and paths within Range 2 (right range) schematically, (b)

3 Determination of boundary particles

4 5. Next, the non-degenerate outermost right-hand particle which is in contact with the bottom

5 wall is recognized. The outermost right dark gray pathway shown in **Figure 4(b)** is then selected

6 as deformable boundary particles because the connectivity between them leads to transmit

7 properly the hydrostatic pressure to the sample.

8 6. During shearing of the biaxial specimen where the sample experiences large deformation, some

9 particles separate from the specimen and pass the boundary. A separate cell is assigned to each

10 individual deformable boundary particle which was identified in stage 5. The cell number, y-

11 coordinate of the bottom and top of each cell and x-coordinate of deformable boundary particle

12 centroid are stored in a four-dimensional array. To recognize those particles separating from

13 the specimen and passing over the deformable boundary particles the following stages need to

14 be implemented:

15 • Comparing the y-coordinate of all particles within the right range with the

16 bottom and top y-coordinates of right cells, defined in the array above, to identify the

17 cell number which can be allocated to each particle.

18 • Comparing the x-coordinate of all particles with the x-coordinate of their

19 corresponding cell number, defined in the array above,

20 • If the x-coordinate of particle is greater than the x-coordinate of its

21 corresponding cell, that particle is marked as a particle outside the boundary. For the

22 left deformable boundary, if the x-coordinate of particle is less than the x-coordinate

23 of its corresponding cell, that particle is marked as a particle outside the boundary.

- 1 7. The inter particle friction of the boundary particles is set to zero because it is assumed that these
 2 particles form the interface between the external pressure and the soil model and only transmit
 3 lateral pressure. In practice, latex is used which is considered a frictionless material [36].
- 4 8. While in practice a uniform pressure is applied, in the DEM model a force is applied to each
 5 boundary particle. The force divided by the effective length is equal to the confining pressure,
 6 $\sigma(t)$, (see **Figure 5(a)**). The effective length is defined by the line connecting the two contact
 7 points which defines the pathway through the particle (see **Figure 5(b)**). The magnitude of this
 8 force for each deformable boundary particle is $\sigma(t) \times$ effective length. The components of the
 9 boundary forces are the product of the external pressure and the effective length (see **Figure**
 10 **5(c)**).

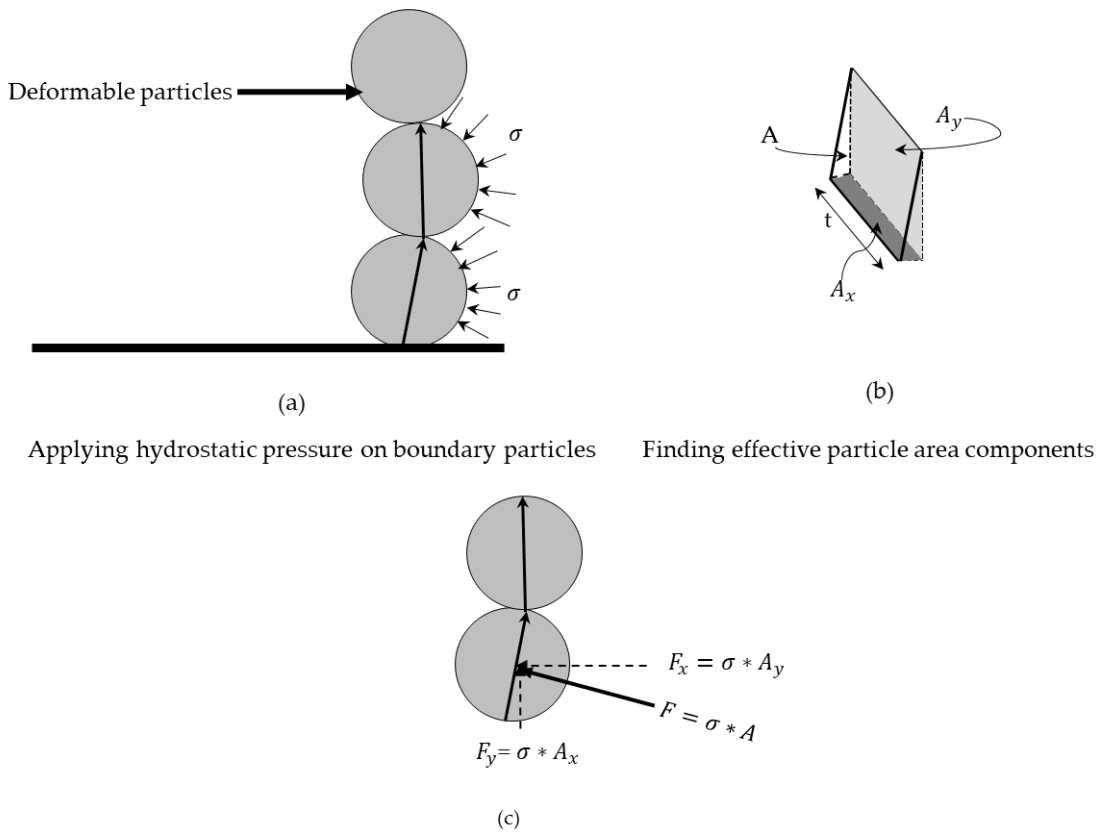

Applying hydrostatic pressure on boundary particles Finding effective particle area components

Applying hydrostatic forces on boundary particles

11
 12 Figure 5 Applying external forces on right boundary particles schematically.

- 13 9. As the deviatoric loading proceeds, some particles near the edge of boundary (white particles
 14 in Figure 4b) may fall outside the boundary by losing their contact with deformable boundary
 15 particles. Once a particle is passed the deformable boundary, a force equal to the $\sigma(t) \times$ particle
 16 diameter is then applied to push them back to the deformable boundary particles in the
 17 following time step. This resembles holding particles using latex with lateral confining pressure
 18 (σ_l) in real experiments where each particle at the edge of boundary faces the aforementioned
 19 pressure, pushing it back to the assembly. The process to identify the boundary particles is
 20 repeated.

- 21 10. The same procedure is applied for the left boundary particles.

1 11. Stages three to nine are invoked every time step.

2 The advantages of this approach over those mentioned before is that the boundary particles are always
3 in real contact though the actual particles forming the boundary may change between time steps. At
4 larger displacements where the biaxial sample is sheared, there is a possibility that the formed particle
5 chain at the boundary changes in each time step, introducing instantaneous changes in the positions in
6 which the boundary is considered during the application of the lateral pressure to the system.

7 6.2. The sensitivity of micro-macro mechanical behaviour of particulate system to the 8 lateral boundary conditions

9 To study the influence of boundary conditions on the micro-macro mechanical behaviour of particulate
10 sand, two biaxial tests were performed. One test was with deformable boundary particles and other
11 was with a rigid wall boundary. To avoid overlapping at the generation stage, disk particles with the
12 size range of 0.5 [mm] and 3 [mm], corresponding to a well graded sand, were initially randomly
13 generated with their half size (i.e. 0.25 [mm] and 1.5 [mm]) within four enclosed rigid walls. Ideally,
14 there should be at least three contacts per idealised disk particle (i.e. the average coordination number)
15 when a granular system is in quasi-static equilibrium. By doing this, the chains' force can transmit across
16 the particulate system. For this purpose, the half-sized generated particles in the biaxial chamber were
17 expanded to achieve the different target porosity of 0.08, 0.09, 0.1, 0.11, 0.12, 0.13, 0.14, 0.15, 0.16 and
18 0.17. It was observed that the samples with target porosity between 0.12 and 0.14 can produce at least
19 three contacts per particle, therefore porosity of 0.12 was chosen for this study. Linear elastic contact
20 model was used in this study. It is to be noted that the inter-particle properties for typical sand used for
21 this study was selected based on the sensitivity of micro-macro mechanical behaviour of sand to the
22 inter-particle properties by Momeni et. al [44]. They conducted thirty DEM biaxial tests to study the
23 sensitivity of the macro-micro mechanical properties of particles to the inter-particle properties of an
24 idealized sand system. Their research identifies the critical parameters and the range over which the
25 parameters impact mass behaviour. The time step required to simulate the biaxial test must be very
26 small to prevent instability of the model. The density scaling approach, originally developed by Sheng
27 et al. [43], was applied in this work to increase the time step and decrease the computational effort of
28 simulations. A dimensionless inertia parameter, I , was introduced to study the effect of density scaling
29 for various strain rates applied to the particulate systems. This method is only applicable for quasi-static
30 simulation where, I , in the following equation must be less than 10^{-3} [43].

$$I = \sqrt{\frac{\dot{\epsilon}^2 \rho r_{min}^2}{p_y}} \quad (20)$$

31 where $\dot{\epsilon}$, r_{min} , p_y and ρ are the strain rate, the minimum radius of the particles, the limiting contact
32 pressure between particles and the density of the particles. There is a transition zone in the behaviour
33 of the materials near $I = 10^{-3}$ for which higher values of I leads to a transient and dynamic behaviour,
34 and the behaviour maintains a quasi-static response for lower values. A sensitivity analysis showed
35 that the particle density $\rho = 2 \times 10^8 \left[\frac{kg}{m^3} \right]$ can reproduce the similar macro-micro behaviour as real particle
36 density $\rho = 2650 \left[\frac{kg}{m^3} \right]$. The particle size distribution is presented in **Figure 6. Table 1** shows the input
37 data used for this study.

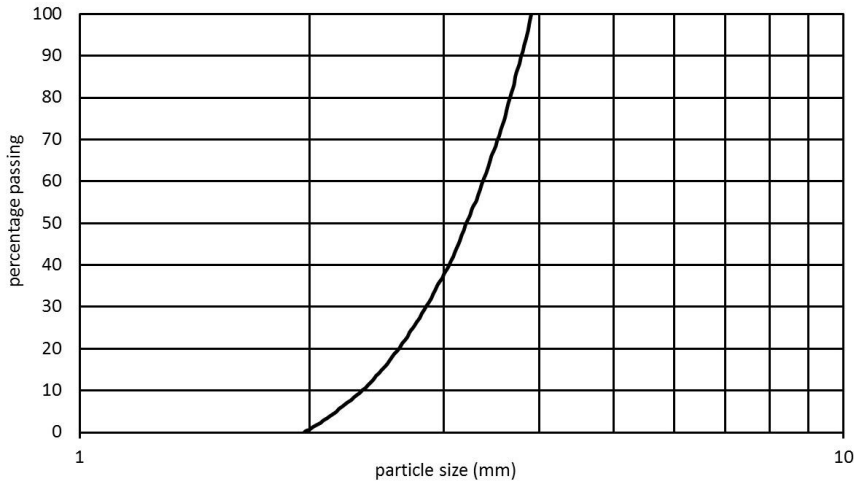

1
2 Figure 6 Particle size distribution

3
4

Initial porosity	0.12
Normal particle stiffness: K_n	8.45×10^7 [N/m]
D_{50}	1.7 [mm]
Shear particle stiffness: K_s	8.45×10^7 [N/m]
Coefficient of friction between particles	0.9
Coefficient of friction between a particle and the platen	0.0
Width	75 [mm]
Height	150 [mm]
Strain rate: $\dot{\epsilon}$	2%/min
Particle density: ρ	2×10^8 [kg/m ³]
Contact pressure: p_y	150 [MPa]

5 Table 1 The initial porosity and micro-mechanical properties of the sample

6 Once the biaxial specimen reaches to the target porosity, the sample was isotropically consolidated to
7 100 [kPa]. Additional cycles were then executed to bring the system to a static equilibrium. From this
8 point forward one test was carried out with rigid boundaries while applying servo-control mechanism
9 to maintain lateral stress of 100 [kPa] during shearing of the sample (see

10 Figure 7b). At the start of each time step, the average stress along the rigid lateral wall, $\sigma^{(w)}$, is
11 calculated by summing the particle-wall contact force (f_c^{pw}) over the area of wall, A .

$$12 \quad \sigma^{(w)} = \frac{\sum f_c^{pw}}{A} \quad (21)$$

13 The wall stress is then compared with the target stress. If the wall stress is equal to $\sigma^{(t)}$, the wall
14 velocity will be set to zero; otherwise the wall velocity, $\dot{u}^{(w)}$, should be adjusted through the following
15 relation:

1 $\dot{u}^{(w)} = G(\sigma^{(w)} - \sigma^{(t)})$ where $G \leq \frac{0.5A}{K_n \Delta t}$ (22)

2 For the other test, the algorithm described above was applied to form deformable lateral boundaries
 3 and control the lateral stress state replaced the rigid boundaries (see

4 **Figure 7**). The top and bottom platens are then moved slowly inward at a constant velocity to perform
 5 a strain-controlled test. The strain rate applied for these two tests was $\frac{2\%}{min}$ such that the incremental
 6 acceleration of each particle at each time step is small. All the imposed energy generated during the
 7 simulation was dissipated through frictional sliding between particles and loss of contacts. During the
 8 deformation of the sample, some boundary particles at the edge of the sample escape. The cell of these
 9 particles is then identified at the current time step. The coordinates of such particles are then not
 10 considered to calculate the volumetric strain and lateral strain until they touch the membrane
 11 boundary. These particles then push back to touch the membrane boundary by applying an external
 12 force to them. Once they touch the boundary, the applied external force on them will be removed.

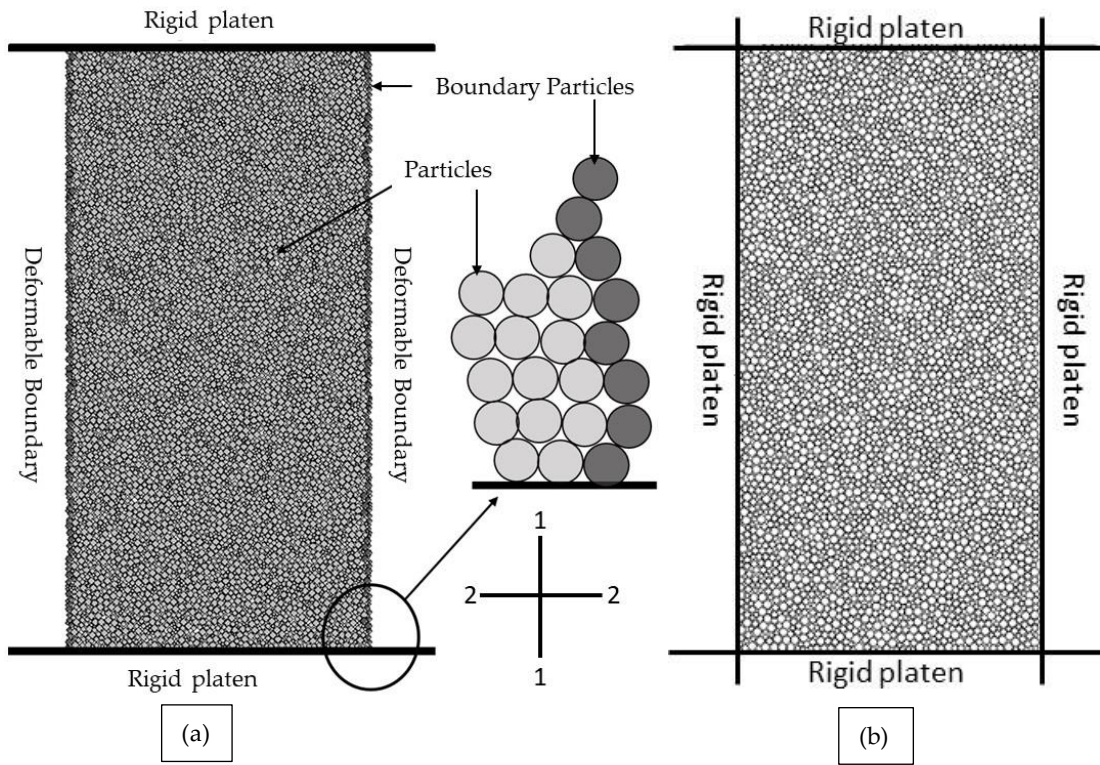

15 Figure 7 The biaxial sample: (a) deformable vertical boundaries, (b) rigid vertical boundaries; 1-1 and 2-2 are the
 16 direction of major and minor axis.

17 To precisely study the macro mechanical behaviour of granular soil, it is essential this system is
 18 investigated at a microscopic scale. To this end, fabric qualities of these two biaxial tests including
 19 average fabric anisotropy, average coordination number and average geometrical stability index with
 20 axial strain are considered. **Figure 8** compares the evolution of polar diagrams of contacts distribution
 21 of both samples during the shearing at three axial strain levels: at $\epsilon_{11} = 0.0\%$ (i.e. at isotropic state), at
 22 axial strain corresponds to peak stress and at $\epsilon_{11} = 10\%$. To draw these polar diagrams, 18 bins were
 23 considered with an angular interval $\Delta\theta = 20^\circ$. The radius of each bin corresponds to the number of
 24 contacts. If the polar diagram is fully circled, it shows that the contact distribution is in an isotropic
 25 state. At $\epsilon_{11} = 0.0\%$, where both samples at macro-scale are isotropically consolidated to 100 [kPa], the
 26 average fabric anisotropy is 0.0034 and a circle can present the analytical contact distribution. The
 27 number of contacts per each segment is distributed almost equally. By applying a deviatoric load, the

1 contacts are aligned in the direction of major principal stress (i.e. 1-1 axis) to take the load. Note, the
 2 direction of major principal stress (axis 1-1) is in the same direction as the deviatoric stress. The average
 3 fabric anisotropy then rises to 0.35 and 0.29 for rigid and deformable boundaries, respectively. This
 4 shows the sample enclosed with four rigid boundaries enables to mobilize more contacts to take more
 5 load. Quantitatively comparing the diameter of the two polar diagrams at peak stress shows that the
 6 diameter of polar diagram for deformable boundaries is around 3200, while it is about 3600 for rigid
 7 boundaries. At $\epsilon_{11} = 10\%$, the orientation of contact points is toward the confining stress and average
 8 fabric anisotropy reduced to 0.27 and 0.18 for rigid and deformable boundaries. This indicates both
 9 systems are not able to mobilize more contacts after peak stress, meaning the particulate system has
 10 been collapsed.

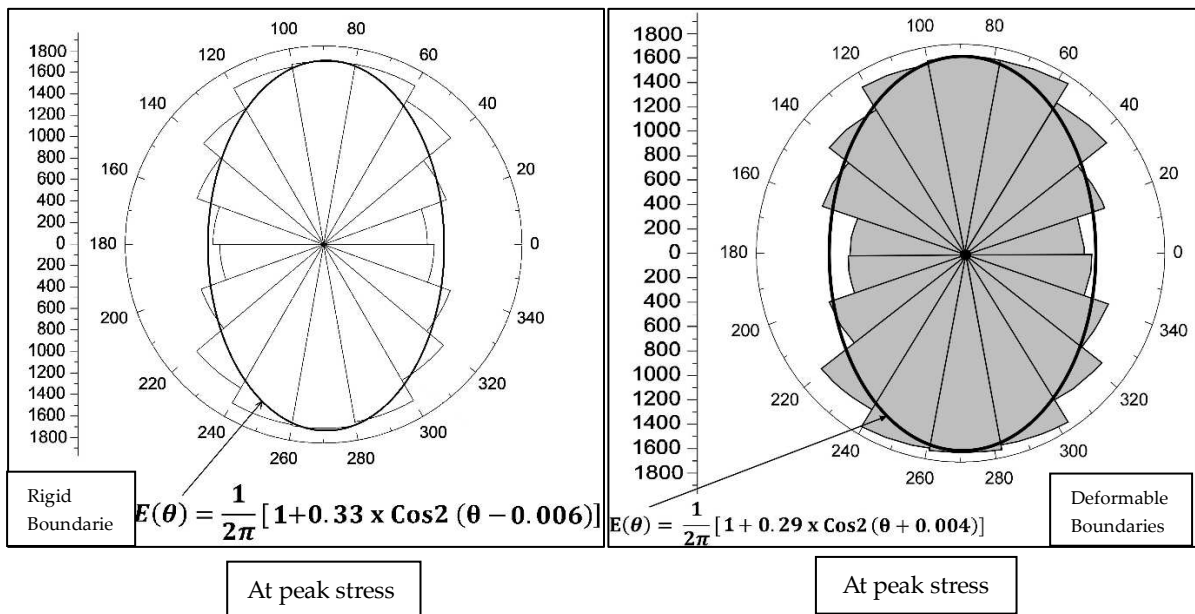
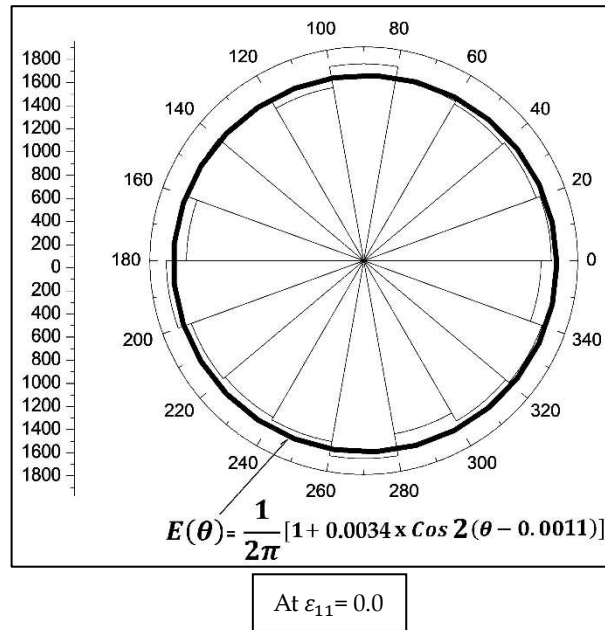

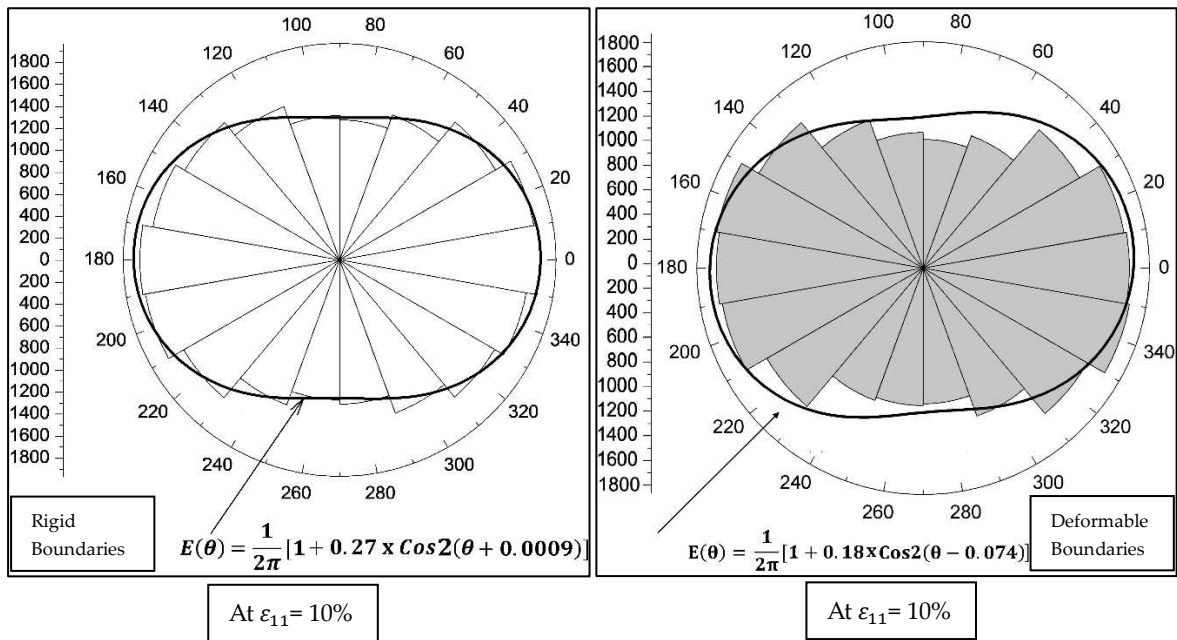
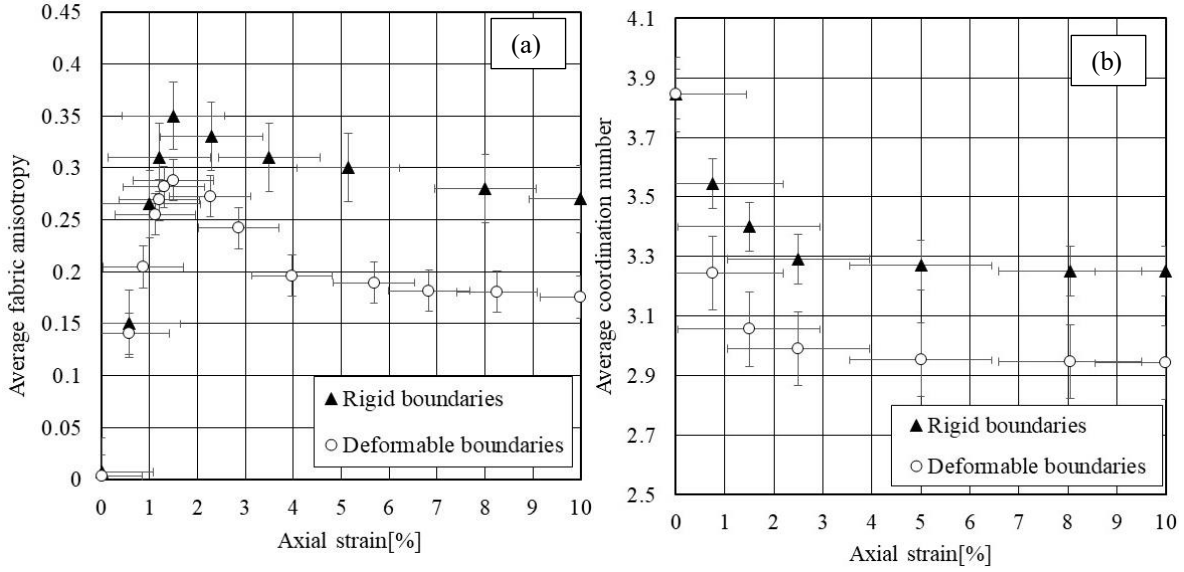

Figure 8 The evolution of contact distribution of particulate: rigid boundaries, deformable boundaries. Note, the unit of radial angle is "Degrees" and the unit of the radius of the polar diagram is "Number of contacts".

Figure 9a compares the variation of average fabric anisotropy vs. axial strain for the rigid and deformable boundaries. Up to an axial strain of about 1%, both simulations present a similar trend. From axial strain of 1% to 1.5%, the peak value of fabric anisotropy for rigid boundaries is more than that for deformable boundaries. The rigid lateral boundaries restrict the shape of lateral deformation and do not allow the particles to move freely. In contrast, particles along the deformable boundaries are free to move during shearing. For the deformable boundaries, the post-peak variation of fabric anisotropy (from the axial strain of about 4%) is less than that of the rigid, suggesting that the test with rigid boundaries probably requires longer time shear to reach the critical state. Figure 9b illustrates the variation of average coordination number against axial strain for different boundary conditions. The trend of average coordination number vs. axial strain between rigid boundaries and deformable boundaries is similar until peak fabric anisotropy. It is about 3.4 for rigid boundaries while it is about 3.0 for deformable boundary. The bigger the average coordination number, the more stable the granular system is. Therefore, the granular system enclosed with rigid boundaries has a bigger strength and is more stable than that with a deformable boundary. The trend remains relatively constant at 3.3 for the rigid boundaries, while it is about 2.9 for deformable boundaries. The reason of this decrease in average coordination number in the case of deformable boundaries after peak is its dilation behaviour. As the rate of dilation increases, the tendency of particles to move and lose their contacts increases and subsequently their stability decreases.



1

2 Figure 9 The sensitivity of (a) Average Fabric anisotropy and (b) average coordination number to the different
 3 boundary condition for rigid and deformable boundary

4 Applying the rigid lateral boundaries to maintain the confining pressures during shearing also results
 5 in a substantial increase in average normal contact forces, \bar{f}_0^c . For example, **Figure 10a** and **Figure 10b**
 6 compare the polar diagram and analytical form of normal contact force distributions for both
 7 deformable and rigid boundaries samples at the end of the test (i.e. $\epsilon_{11} = 10\%$). Similar to the polar
 8 diagram of contact distribution, 18 bins are taken into account with an angular interval $\Delta\theta = 20^\circ$ to
 9 draw polar diagram of normal contact force distribution. The radius of each bin corresponds to the
 10 summation of normal contact forces. The average normal contact forces, \bar{f}_0^c , at the end of the test are
 11 significantly different between these two models. As highlighted, the value of average contact forces is
 12 160.82 [N] for the model using deformable boundaries, while it is 658.277 [N] for rigid boundaries. This
 13 notable discrepancy between these two values is because of the interaction between the rigid walls and
 14 the neighboring particles and the lack of free deformation at the lateral boundaries.

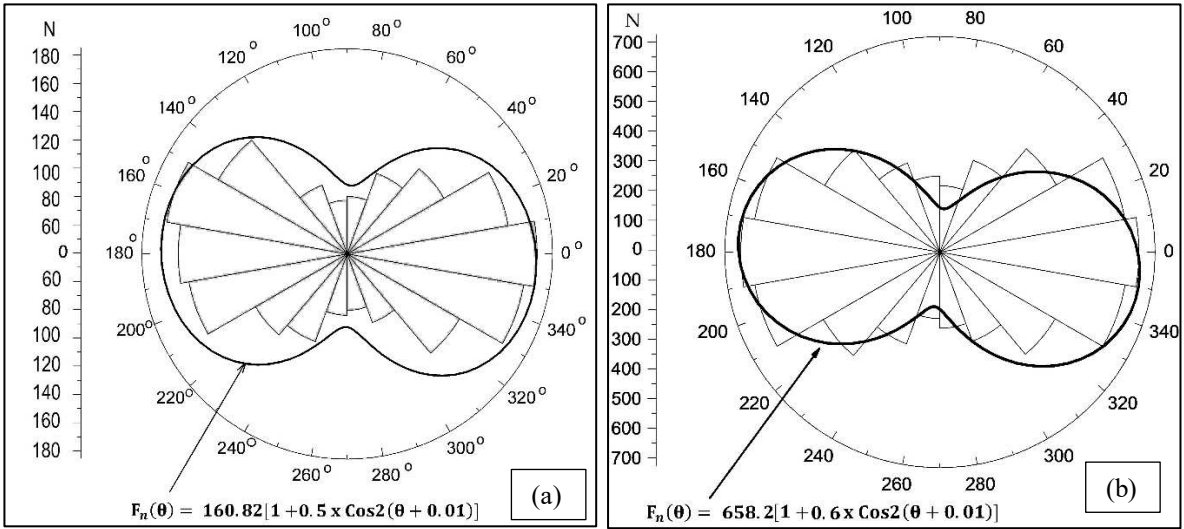

15

16 Figure 10 Normal contact force distribution at $\epsilon_{11} = 10\%$, (a) deformable boundary particles, (b) rigid boundary

17 The variations of average geometrical stability index for both samples are shown in **Figure 11a**. An
 18 equal distribution of contacts of an idealised 2D particle is defined as the most stable contact distribution

1 and the deviation of the contact distribution from the most stable contact distribution is the geometrical
 2 stability index. It is seen that when the samples are in an isotropic state, the average geometrical stability
 3 index is about 0.22. That means that the contacts around each idealised disk particle are not in a stable
 4 configuration. However, the value of this micro-scale descriptor increases for both samples during
 5 shearing. Up to an axial strain of about 1.5%, where the contacts are orientated toward the major
 6 principal stress and corresponds the peak fabric anisotropy and inflection point in average coordination
 7 number, the trend of average geometrical stability index significantly increases to around 0.33 and 0.35
 8 for deformable boundaries and rigid boundaries, respectively. However, beyond this point this
 9 behaviour significantly diverged such that the trend for deformable boundary significant dropped to
 10 around 0.29 at an axial strain of about 4% and then slightly reduced to a value of 0.27 at the end of test.
 11 This trend for rigid boundary gradually increases from an axial strain of about 4% to the end of the test.
 12 It found that there is a correlation between the response of average geometrical stability index and fabric
 13 anisotropy for both models (see **Figure 11b**). Readers refer to Momeni et al. [7] for more details of
 14 average geometrical stability index.

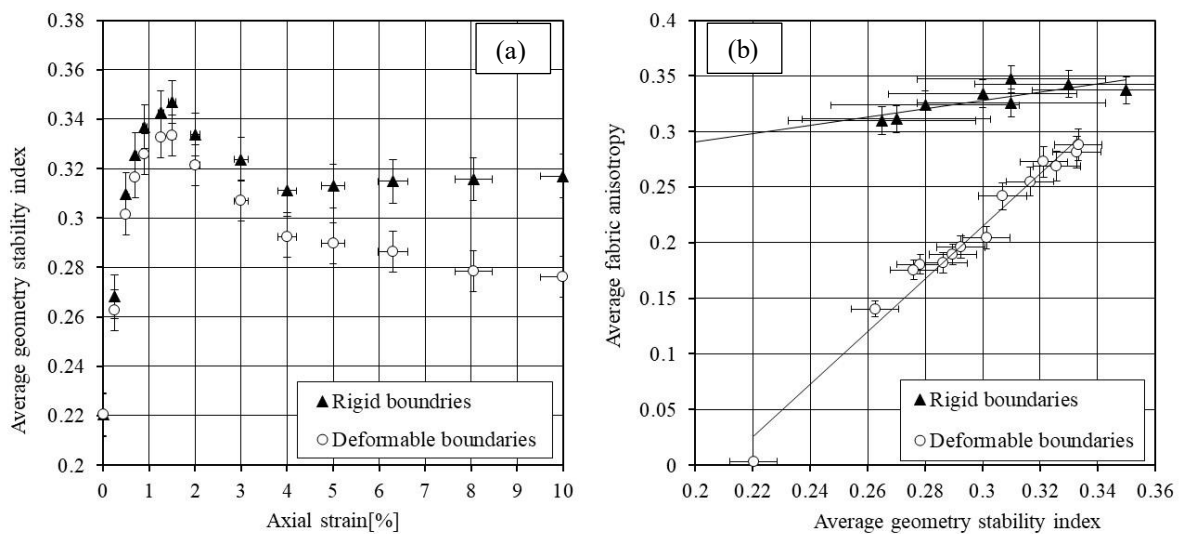

15
 16 Figure 11 (a) The sensitivity of average geometrical stability index to the different boundary condition, linear
 17 coloration between average fabric anisotropy and average geometrical stability index

18 **Figure 12** shows that the trend of deviatoric stress ratio (ratio of axial stress to confining stress) with
 19 axial strain between these two models is similar up to an axial strain of about 1%. However, from this
 20 point to an axial strain of about 1.5% the sample with the rigid boundary and deformable lateral
 21 boundaries reach to a peak deviatoric stress ratio of 2.6 and 2.3, respectively, which is in agreement
 22 with the work of Cheung and O'Sullivan [41]. The reason for a higher peak deviatoric stress ratio
 23 associated with rigid boundaries is that the lateral movement of the particles is strictly restricted. This
 24 results in generating considerable inter-particle and particle-wall contact deformations. That is, the
 25 contact forces significantly grow during loading. As a result of this, the sliding capacity of contacts as
 26 shown in **Equation 4** significantly increases and consequently the system can take a higher load. Both
 27 samples show a notable drop from the peak deviatoric stress ratio up to the axial strain of 4% (i.e. within
 28 the softening-strain behaviour). Beyond this axial strain, the deviatoric stress ratio for the model with
 29 deformable lateral boundaries has a very slow change, showing the system approaches to the critical
 30 state behaviour. However, the stress ratio for the model with rigid lateral boundaries showed growth
 31 from the axial strain of 4% to the end of the test, which is not compatible with the typical behaviour of
 32 Sand. The volumetric strain behaviour of these two models is demonstrated in **Figure 12b**. Both
 33 samples show a contraction in the volumetric strain around the peak deviatoric stress ratio. However,
 34 the sample with deformable boundaries shows a slightly larger contraction. The deformable boundaries
 35 allow the particles to move freely, therefore, the average coordination number from an axial strain of

1 0% to 1.5% decreases by about 20%, while this fall is over 12% for the rigid boundary (see **Figure 9b**).
 2 That is, the loss of contacts in the case of the rigid boundary is less than that for the deformable
 3 boundary. Thus, during the contraction, the sample with the deformable boundary experiences higher
 4 contraction. From this axial strain to an axial strain of 3%, both samples partially show a similar dilation
 5 behaviour. Changes in the trend of volumetric strain by increasing axial strain beyond this point for the
 6 model with deformable boundaries are substantially smaller than that of rigid boundary, indicating the
 7 system approaches a critical state behaviour. When soil sample under shearing reaches the critical state
 8 behaviour, changes in volumetric and deviatoric stress ratio responses become constant at some point
 9 at post-peak (e.g. Wood [4] and Verdugo and Ishihara [46]). In contrast, the trend of volumetric strain
 10 shows a rise notably by increasing axial strain for the model with lateral rigid boundaries from an axial
 11 strain of about 3% to the end of the test, indicating longer shear and more time is required for the model
 12 with rigid boundary to reach the critical state (e.g. Gu, et al. [47] and Nguyen et al. [48]). Soil will reach
 13 a unique critical state during shearing, at which it deforms continuously with a constant stress state,
 14 constant volumetric state, constant coordination number, constant fabric anisotropy and constant
 15 stability index. Tracking these parameters as shear proceeds demonstrates when the soil will reach to
 16 the critical state behaviour.

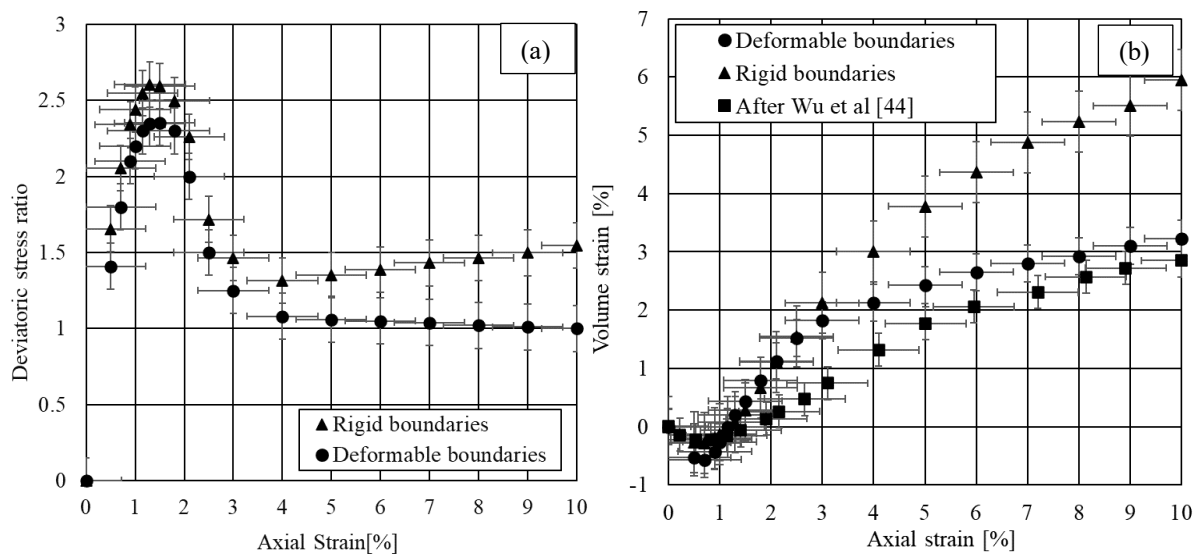

17
 18 Figure 12 The sensitivity of macro-mechanical behaviour of the system to the different boundary condition:
 19 deviatoric stress ratio vs. axial strain, volumetric strain vs. axial strain
 20 The dilation behaviour of the model with deformable boundaries at post-peak is more representative
 21 of the typical volumetric behaviour of sand. **Figure 12b** qualitatively compares the volumetric behavior
 22 of sand carried out by Wu et al. [44] and the present study. The different between the volumetric
 23 behavior of these two works is mainly because of particle size distribution and strain rate. Wu et al. [44]
 24 applied a strain rate of 5%/min while in this work it was 2%/min.

25 **Table 2** summaries the sensitivity of macro-mechanical elasto-plastic parameters to the boundary
 26 conditions.

Elasto-plastic parameters	Lateral boundary Condition	
	Rigid	Deformable
E (MPa)	35	30

Poisson's ratio	0.18	0.20
\emptyset (°) (angle of internal friction)	27	24

1 Table 2 The sensitvity of macro-mechanical elasto-plastic parameters to the boundary condition

2 The difference between the computed Young's modulus of rigid and deformable boundaries is 17%.
3 This difference between the computed Poisson's ratio between of deformable and rigid boundaries is
4 11%. As the peak stress for the sample with rigid boundary is higher than that with a deformable
5 boundary, the angle of internal friction for rigid boundary is about 9% bigger than that for the
6 deformable boundary. The angle of internal friction is computed from peak deviatoric stress as follows:

$$\frac{t}{s} = \text{Tan}^2\left(45 + \frac{\emptyset}{2}\right) \quad (23)$$

7 where t is the deviatoric stress and s is the isotropic stress.

8 7. The sensitivity of Shear band to the lateral boundary conditions

9 In soil mechanics, shear band refers to a diagonal shear strain localization, characterised by large
10 amount of shear strain [45, 14, 46]. Within this zone, particles experience higher amount of rotation but
11 less movements [41, 14, 7]. Momeni et al. [7] stated that particles which locate within this zone have less
12 contacts compared with the rest of particles and therefore they are less stable. That is, the shear band
13 behaviour is influenced by particle rotations rather than particle displacements [44]. Momeni et al. [7]
14 also showed that those particles that are within this zone have at least two contacts. Sadrekarimi and
15 Olson [47] stated that the onset of shear band is when soil reaches to the elastic limit. In the classical soil
16 mechanics, Coulomb's yield criterion is generally applied to predict the inclination angle of shear band
17 of fine granular materials which is based on the force equilibrium on the failure plane. According to
18 this theory where the ratio of shear stress to normal stress is a maximum at shear only for non-cohesive
19 particulates, the inclination angle of shear band, ϕ_c , can be measured from the direction of minor
20 principal stress, which is orthogonal to the deviatoric stress direction in a biaxial test (see 21.a). The
21 inclination angle of shear band, ϕ_c , can be measured by following empirical relationship:

$$22 \quad \phi_c = 45^\circ + \frac{\emptyset}{2} \quad (24)$$

23 For coarse granular soils, Roscoe theory is applied to predicts the angle of shear band inclination, where
24 dilatancy angle (i.e. ϕ) is used to calculate angle of shear band inclination, ϕ_R , [48].

$$25 \quad \phi_R = 45^\circ + \frac{\phi}{2} \quad (25)$$

26 The significant difference between **Equation (24)** and **Equation (25)** is that the dilatancy angle is much
27 smaller than the angle of internal friction. **Figure 13(b)** to **Figure 13(f)** presents the contour plots of the
28 development of particles displacements during shearing at different axial strain levels for the model
29 with lateral deformable boundaries. As the sample is sheared, a diagonal zone in which the particles
30 displacements are less than the rest of sample is formed. At small axial strain level, the formation of
31 shear band is evident. From axial strain 0.7% to axial strain corresponds to the peak stress (i.e. $\epsilon_{11} =$
32 1.5%) the shear band is well formed, and particles experience large amount of displacement. As the bulk
33 dilation increase, the geometry of particles displacements changes notably (e.g. compare particles
34 displacements at $\epsilon_{11} = 0.5\%$ and $\epsilon_{11} = 1.5\%$). From $\epsilon_{11} = 1.5\%$ to $\epsilon_{11} = 10\%$, two wedges failure forms
35 and particles experience higher displacements. This shear band is qualitatively in a good agreement
36 with that shown in **Figure 13(g)** carried out by Kawamoto et al. [14]. Kawamoto et al. [14]**Error!**
37 **Reference source not found.** implemented triaxial tests on the coarse sand to study the shear band

1 behaviour, where the samples were isotropically consolidated to 100[kPa]. They loaded the samples up
 2 to axial strain 15% and reported a dilatancy angle and the angle of inclination of shear band of 10° and
 3 50°, respectively. **Figure 13(h)** shows the shear band is clearly formed for the model with lateral rigid
 4 boundary at $\varepsilon_{11} = 10\%$. Simple measurements were made to estimate the orientation of the shear band
 5 of those models used deformable lateral boundaries and rigid lateral boundaries which are 56° and 62°.
 6 With the angle of internal friction provided in **Table 2**, the inclination of the shear band calculated from
 7 **Equation (24)** for the model with deformable and rigid boundaries are 57° and 59° respectively. The
 8 measured angle of shear band for the model with deformable lateral boundaries is in good agreement
 9 with that calculated from **Equation (24)**, while the measured angle of shear band for the model with
 10 rigid lateral boundaries is bigger from that calculated from **Equation (24)**. Alshibli and Sture [49]
 11 measured shear band thickness using digital imaging techniques by implementing a number of
 12 experimental biaxial tests on sands, where the samples were isotropically consolidated to 100[kPa].
 13 They recommended the following empirical relationship to estimate the thickness of shear band:

$$14 \quad t_s = (10 - 11) \times D_{50} \quad (26)$$

15 Using simple measurement, the thickness of shear band for the model with deformable and rigid boundaries are
 16 17.5mm and 15mm, respectively. The authors implemented this relationship to estimate the shear band thickness
 17 for both models. By applying **Equation (26)**, the thickness of shear band is “10.5x1.7=17.8mm” which is in good
 18 agreement with the measured shear band thickness attained from the model with deformable lateral boundaries. It
 19 should be noted that in two-dimensional simulation, a particle has three degrees of freedom and is restricted to
 20 move and rotate only in-plane while in three-dimensional modelling a particle has six degrees of freedom and is
 21 free to move and rotate in any direction without no restriction. Additionally, the number of contacts per particle
 22 in 3D models is more than that in 2D models. Hence, longer shear is required that a shear band to be formed for
 23 3D particulate systems in comparison with 2D models. As bulk deformation is restricted in-plane in 2D systems,
 24 the 2D models are stiffer than the 3D systems. Chung and O’Sullivan [41] qualitatively studied the shear behaviour
 25 of particulate soils under 2D biaxial and 3D triaxial simulations using DEM. They showed that those particles that
 26 fall within the shear band in 2D systems experience more rotation in comparison with particles’ rotation within
 27 the shear band in 3D systems. They also indicated that the bulk shear capacity of particulate soils in 3D systems
 28 is greatly dependent on the particles’ rotation in radial directions such that particles that fall into the shear band
 29 experience similar values of rotation in lateral radial directions.

30

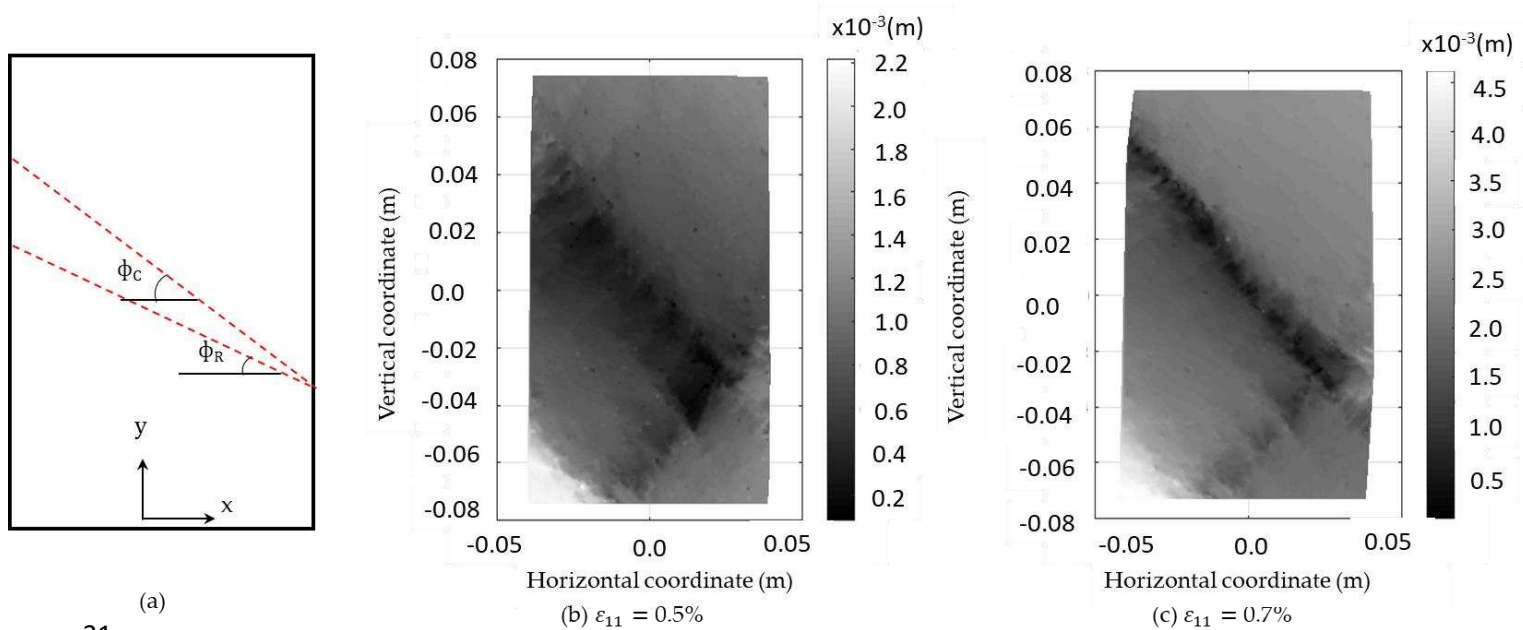

31

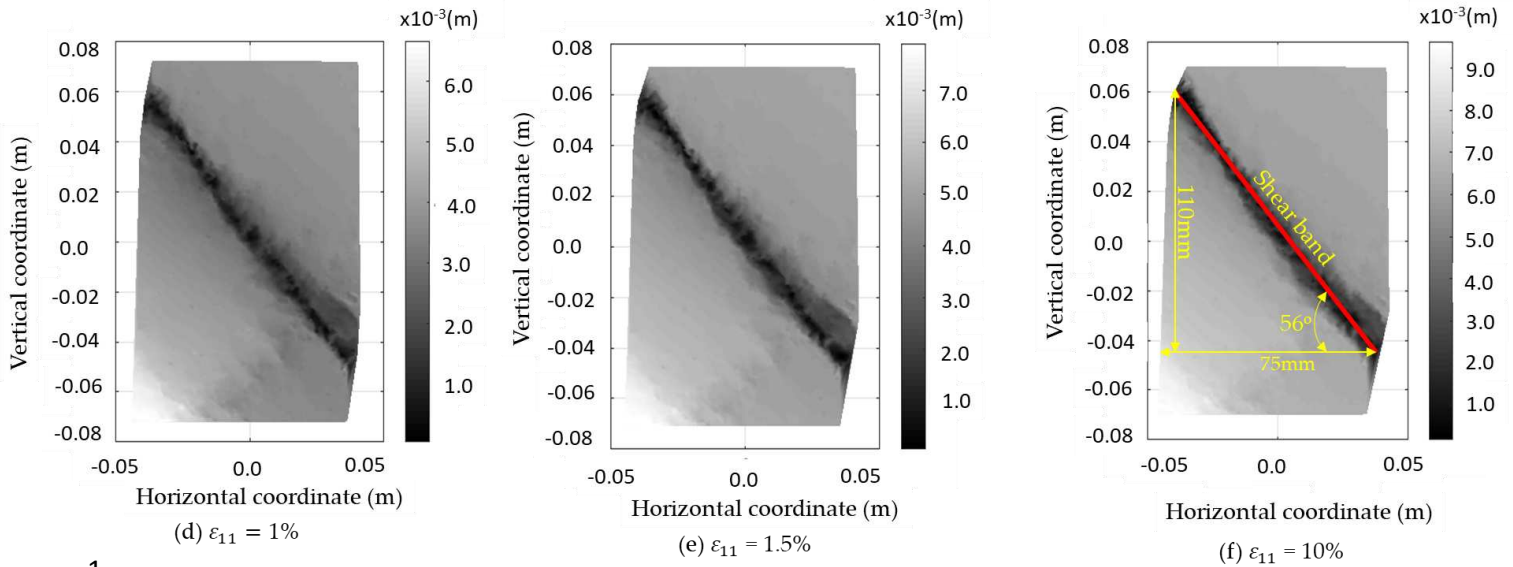

1

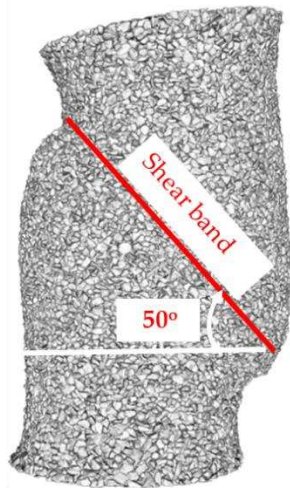

(g) At $\varepsilon_{11} = 15\%$ (After Kawamoto et al. [14])

2

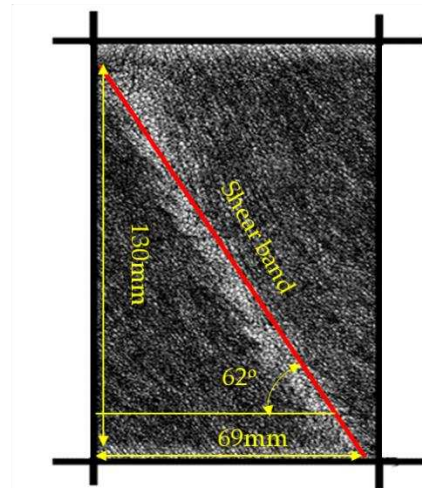

(h) $\varepsilon_{11} = 10\%$

3 Figure 13 (a) shear band inclination angle based on Coulomb and Roscoe theories, (b to f) Evolution of shear
 4 band during shearing for deformable lateral boundaries, (g) Experimental shear band formation at axial strain
 5 15% (Kawamoto et al. [14]) and (h) shear band formation at axial strain 15% for rigid lateral boundaries. The grey
 6 bar is displacement.

7 8. Conclusion

8 An algorithm to implement the deformable lateral boundaries for the 2D DEM biaxial test is presented
 9 in this paper where the micro-mechanical behaviors of particles are studied, and compared with the
 10 case of rigid boundaries:

- 11 - Tracking the variation of average fabric anisotropy shows that from axial strain of about 1.5%
 12 onwards, the average fabric anisotropy for both systems reduces, indicating the particulate
 13 systems are not able to develop more contacts per particle to take the higher major principal
 14 stress. This drop in average fabric anisotropy from axial strain 1.5% onwards is more notable
 15 for the model with deformable boundary particles.

1 - It is found that the model with rigid boundaries leads to higher value of average fabric
2 anisotropy and average geometrical stability index. In particular, as the sample is sheared, after
3 the peak stress the instability index constantly reduces to the end of the test for the model with
4 deformable boundaries, while rigid boundaries shows a slight increase of average geometrical
5 stability index after a strain of about 4%.

6 - Tracing the evolution of particle movements during shearing for the model with deformable
7 lateral boundaries shows the angle of inclination of the shear band develops long before peak
8 stress is achieved. The measured thickness of the shear band and inclination of the shear band
9 from the model with deformable lateral boundaries are in good agreement with the value of
10 shear band thickness and inclination of shear band calculated from empirical equations.

11 The DEM modeling tests suggest that the developed algorithm for the deformable boundary could
12 improve the accuracy of modeling soil samples and can better represent the actual behavior of
13 granular soils.

14

15 9. References

16

- [1] B. Das, "Soil mechanics laboratory manual," New York, USA, Oxford University Press, 2002, pp. 99-108.
- [2] K. Head, "Manual of soil laboratory testing (Vol. 1, No. 2)," Pentech press, London, 1980.
- [3] T. a. W. R. Lambe, Soil mechanics, New York: John Willey & Sons. Inc, 1969.
- [4] D. Wood, Soil behaviour and critical state soil mechanics, Cambridge : Cambridge university press, 1990.
- [5] P. a. S. O. Cundall, "A discrete numerical model for granular assemblies. , G," *geotechnique*, vol. 29, no. 1, pp. 47-65, 1979.
- [6] J. T. J. a. M. H. Kozicki, "Discrete simulations of a triaxial compression test for sand by DEM," *International Journal for Numerical and Analytical Methods in Geomechanics*, vol. 38, no. 18, pp. 1923-1952, 2014.
- [7] A. C. B. a. S. Y. Momeni, "An Introduction to the Geometrical Stability Index: A Fabric Quantity," *Geotechnics*, vol. 2, no. 2, pp. 297-316, 2022.
- [8] M. N.-N. S. a. K. J. Oda, "Stress-induced anisotropy in granular masses," *Soils and foundations*, vol. 25, no. 3, pp. 85-97, 1985.
- [9] L. a. B. R. Rothenburg, "Analytical study of induced anisotropy in idealized granular materials.," *Geotechnique*, vol. 39, no. 4, pp. 601-614, 1989.

- [10] L. a. K. N. Rothenburg, "Critical state and evolution of coordination number in simulated granular materials," *International Journal of Solids and Structures*, vol. 41, no. 21, pp. 5763-5774, 2004.
- [11] A. C. F. I. T. a. L. J. Fakhimi, "Simulation of failure around a circular opening in rock," *International Journal of Rock Mechanics and Mining Sciences*, vol. 39, no. 4, pp. 507-515, 2002.
- [12] F. M. C. a. D. F. Camborde, "Numerical study of rock and concrete behaviour by discrete element modelling," *Computers and geotechnics*, vol. 27, no. 4, pp. 225-247, 2000.
- [13] M. K. H. a. K. J. Oda, "Effects of induced anisotropy on the development of shear bands in granular materials.," *Mechanics of materials*, vol. 28, no. 1, pp. 103-111, 1998.
- [14] R. A. E. V. G. a. A. J. Kawamoto, "All you need is shape: Predicting shear banding in sand with LS-DEM," *Journal of the Mechanics and Physics of Solids*, vol. 111, pp. 375-392, 2018.
- [15] Itasca, "Particle Flow Code 2D (PFC2D)," Itasca, Minneapolis, USA, 2014.
- [16] K. a. O. M. Iwashita, "Rolling resistance at contacts in simulation of shear band development by DEM," *Journal of engineering mechanics*, vol. 124, no. 3, pp. 285-292, 1998.
- [17] M. a. I. K. Oda, "Mechanics of granular materials: an introduction," *CRC press*, 2020.
- [18] C. a. Z. L. Thornton, "Numerical simulations of the direct shear test," *Chemical Engineering & Technology*, vol. 26, no. 2, pp. 153-156, 2003.
- [19] T. Sitharam, "Discrete element modelling of cyclic behaviour of granular materials," *Geotechnical & Geological Engineering*, vol. 21, no. 4, pp. 297-329, 2003.
- [20] D. a. C. P. Potyondy, "A bonded-particle model for rock," *International journal of rock mechanics and mining sciences*, vol. 41, no. 8, pp. 1329-1364, 2004.
- [21] C. D. B. J. a. L. S. O'Sullivan, "A new approach for calculating strain for particulate media," *International Journal for numerical and analytical methods in geomechanics*, vol. 27, no. 10, pp. 859-877, 2003.
- [22] C. O'Sullivan, *Particulate discrete element modelling*, Taylor & Francis, 2011.
- [23] X. H. K. O. C. a. K. C. Huang, "Implementation of rotational resistance models: A critical appraisal.," *Particuology*, vol. 34, pp. 14-23, 2017.
- [24] P. Y. Z. Z. W. a. C. W. Wang, "Micro-mechanical analysis of soil-structure interface behavior under constant normal stiffness condition with DEM," *Acta Geotechnica*, vol. 17, no. 7, pp. 2711-2733, 2022.
- [25] K. J. a. K. Johnson, *Contact Mechanics*, Cambridge University Press, 1987.
- [26] L. & B. R. Rothenburg, "Analytical Study of Induced Anisotropy in Idealized Granular Materials.," vol. 39, pp. 601-614, 1989.

- [27] L. Rothenburg, "Micromechanics of idealized granular assemblies," PhD Thesis , University of Waterloo, Canada, 1980.
- [28] R. M. German, "Coordination Number Changes During Powder Densification," vol. 253, p. 368–376, 2014.
- [29] T. Ng, "Fabric Evolution of Ellipsoidal Arrays With Different Particle Shapes.," vol. 127, pp. 994–999, 2001.
- [30] L. a. K. N. Rothenburg, "Critical state and evolution of coordination number in simulated granular materials," *International Journal of Solids and Structures*, vol. 41, no. 21, pp. 5763-5774, 2004.
- [31] K. Maeda, "Critical State-based Geo-micromechanics on Granular Flow," *American Institute of Physics*, vol. 1145, no. 1, pp. 17-24, 2009.
- [32] A. Momeni, "Micro-mechanical study of sand fabric during earthquake (Doctoral dissertation)," University of Leeds, Leeds, UK, 2014.
- [33] R. G. M. a. A. S. Moreno, "Effect of the impact angle on the breakage of agglomerates: a numerical study using DEM," *Powder Technology*, vol. 130, no. 1, pp. 132-137, 2003.
- [34] N. P. J. D. F. D. F. a. S. A. Belheine, "Numerical simulation of drained triaxial test using 3D discrete element modeling," *Computers and Geotechnics*, vol. 36, no. 1-2, pp. 320-331, 2009.
- [35] C. a. A. S. Thornton, "Quasi-static shear deformation of a soft particle system," *Powder technology*, vol. 109, no. 1, pp. 179-191, 2000.
- [36] L. O. C. a. O. S. Cui, "An analysis of the triaxial apparatus using a mixed boundary three-dimensional discrete element model," *Geotechnique*, vol. 57, no. 10, pp. 831-844, 2007.
- [37] U. a. D. C. El Shamy, "Microscale characterization of energy dissipation mechanisms in liquefiable granular soils," *Computers and Geotechnics*, vol. 37, no. 7, pp. 846-857, 2010.
- [38] N. a. E. S. U. Zamani, "Analysis of wave propagation in dry granular soils using DEM simulations," *Acta Geotechnica*, vol. 6, no. 3, pp. 167-182, 2011.
- [39] Itasca, "Particle Flow Code in Three Dimensions," Itasca, Minneapolis, USA, 2014.
- [40] Y. a. L. S. Wang, "Characterization of cemented sand by experimental and numerical investigations," *Journal of geotechnical and geoenvironmental engineering*, vol. 134, no. 7, pp. 992-1004, 2008.
- [41] G. a. O. C. Cheung, "Effective simulation of flexible lateral boundaries in two-and three-dimensional DEM simulations," *Particuology*, vol. 6, no. 6, pp. 483-500, 2008.
- [42] J. O. C. a. M. G. O'Donovan, "Two-dimensional discrete element modelling of bender element tests on an idealised granular material.," *Granular Matter*, vol. 14, no. 6, pp. 733-747, 2012.
- [43] Y. L. C. B. B. & T. C. Sheng, "Numerical Studies of Uniaxial Powder Compaction Process By 3D DEM.," vol. 21, pp. 304-317, 2004.

- [44] K. L. S. S. W. R. S. Wu, "DEM study of the shear behavior and formation of shear band in biaxial," *Adv. Powder Technol*, vol. 31, pp. 1431-1440, 2020.
- [45] J. a. C. R. Desrues, "Shear band analysis and shear moduli calibration," *International Journal of Solids and Structures*, vol. 39, no. 13-14, pp. 3757-3776, 2002.
- [46] V. a. S. H. Galavi, "Nonlocal multilaminate model for strain softening analysis," *International Journal of Geomechanics*, vol. 10, no. 1, pp. 30-44, 2010.
- [47] A. a. O. S. Sadrekarimi, "Shear band formation observed in ring shear tests on sandy soils," *Journal of geotechnical and geoenvironmental engineering*, vol. 136, no. 2, pp. 366-375, 2010.
- [48] P. A. Vermeer, "The orientation of shear band in biaxial tests," *Geotechnique*, vol. 40, no. 2, pp. 223-236, 1990.
- [49] K. a. S. S. Alshibli, "Sand shear band thickness measurements by digital imaging techniques," *Journal of computing in civil engineering*, vol. 13, no. 2, pp. 103-109, 1999.
- [50] C. B. J. a. R. M. O'Sullivan, "Influence of particle shape and surface friction variability on response of rod-shaped particulate media.," *Journal of Engineering Mechanics*, vol. 128, no. 11, pp. 1182-1192, 2002.

1

2

Nomenclature

$\dot{\mathbf{x}}$ translational Particle velocity	$\dot{\boldsymbol{\theta}}$ rotational Particle velocity
θ_a rotation of $E(\theta)$	θ_n direction of $\bar{\mathbf{f}}_n^c(\boldsymbol{\theta})$
$\bar{\mathbf{f}}_0^c$ average normal forces	C_n Average coordination number
Δ_n Normal contact deformation	a Fabric anisotropy
Δ_t Time step	Δ_s Shear contact deformation
θ Angle of contact force from x-axis and angle friction	
α Damping constant	$\dot{\epsilon}$ Strain rate
K_s Tangential contact stiffness	K_n Normal contact stiffness
\mathbf{F}_i^n Total normal contact force	\mathbf{F}_i^s Total tangential contact force
ρ Particle density	$\dot{\epsilon}$ Strain rate
p_y Contact pressure	I density scaling factor
\mathbf{F}_i contact force	a_n normal contact force anisotropy
\mathbf{F} Resultant force	\mathbf{M} Torque
\mathbf{F}_i^d Local damping force	\mathbf{n} and \mathbf{t} unite vector
ν Particle velocity and Poisson's ratio	
R Particle radius	ϕ_C Angle of shear band: Coulomb's theory
t Deviatoric stress	s Isotropic stress
E Young's Modulus	ϕ_R Angle of shear band: Roscoe's theory
ϵ_{11} Major Strain tensor component in axial direction	
ϵ_v Volumetric strain	φ dilatancy angle
D_{50} Mean particle size	t_s thickness of shear band
μ coefficient of friction	\mathbf{u}_x Particle velocity in x-direction
\mathbf{u}_y Particle velocity in y-direction	σ_t Target stress

1

2