

The development of a miniaturised balloon-borne cloud water sampler and its first deployment in the high Arctic

Julika Zinke, Matthew E. Salter, Caroline Leck, Michael J. Lawler, Grace C. E. Porter, Michael P. Adams, Ian M. Brooks, Benjamin J. Murray & Paul Zieger

To cite this article: Julika Zinke, Matthew E. Salter, Caroline Leck, Michael J. Lawler, Grace C. E. Porter, Michael P. Adams, Ian M. Brooks, Benjamin J. Murray & Paul Zieger (2021) The development of a miniaturised balloon-borne cloud water sampler and its first deployment in the high Arctic, *Tellus B: Chemical and Physical Meteorology*, 73:1, 1-12, DOI: [10.1080/16000889.2021.1915614](https://doi.org/10.1080/16000889.2021.1915614)

To link to this article: <https://doi.org/10.1080/16000889.2021.1915614>



Tellus B: 2021. © 2021 The Author(s).
Published by Informa UK Limited, trading as
Taylor & Francis Group



Published online: 08 May 2021.



Submit your article to this journal [↗](#)



Article views: 14



View related articles [↗](#)



View Crossmark data [↗](#)

The development of a miniaturised balloon-borne cloud water sampler and its first deployment in the high Arctic

By JULIKA ZINKE^{1,2}, MATTHEW E. SALTER^{1,2}, CAROLINE LECK^{2,3}, MICHAEL J. LAWLER⁴, GRACE C. E. PORTER⁵, MICHAEL P. ADAMS⁵, IAN M. BROOKS⁵, BENJAMIN J. MURRAY⁵, and PAUL ZIEGER^{1,2*}, ¹*Department of Environmental Sciences, Stockholm University, Stockholm, Sweden;* ²*Bolin Centre for Climate Research, Stockholm University, Stockholm, Sweden;* ³*Department of Meteorology, Stockholm University, Stockholm, Sweden;* ⁴*Department of Chemistry, University of California, Irvine, Irvine, California, USA;* ⁵*School of Earth and Environment, University of Leeds, Leeds, UK*

(Manuscript Received 10 January 2020; in final form 1 April 2021)

ABSTRACT

The chemical composition of cloud water can be used to infer the sources of particles upon which cloud droplets and ice crystals have formed. In order to obtain cloud water for analysis of chemical composition for elevated clouds in the pristine high Arctic, balloon-borne active cloud water sampling systems are the optimal approach. However, such systems have not been feasible to deploy previously due to their weight and the challenging environmental conditions. We have taken advantage of recent developments in battery technology to develop a miniaturised cloud water sampler for balloon-borne collection of cloud water. Our sampler is a bulk sampler with a cloud drop cutoff diameter of approximately 8 µm and an estimated collection efficiency of 70%. The sampler was heated to prevent excessive ice accumulation and was able to operate for several hours under the extreme conditions encountered in the high Arctic. We have tested and deployed the new sampler on a tethered balloon during the Microbiology-Ocean-Cloud-Coupling in the High Arctic (MOCCHA) campaign in August and September 2018 close to the North pole. The sampler was able to successfully retrieve cloud water samples that were analysed to determine their chemical composition as well as their ice-nucleating activity. Given the pristine conditions found in the high Arctic we have placed significant emphasis on the development of a suitable cleaning procedure to minimise background contamination by the sampler itself.

Keywords: instrument development, balloon-borne sampling, cloud water composition, Arctic, clouds, cloud water sampling

1. Introduction

The collection of fog or cloud water with a subsequent analysis of chemical composition is an essential tool to better understand the role of aerosol in the formation and removal by cloud droplets or ice crystals. A variety of cloud water collectors have been developed in the recent decades, including passive, active, single-stage and size-resolved collectors. For a more detailed overview, the reader is referred to the reviews by Hering et al. (1987), Skarżyńska et al. (2006) and Roman et al. (2013). Among

those instruments, the Caltech active strand cloud water collector (CASCC) developed by Daube et al. (1987) has become one of the preferred sampling instruments in many studies and has been further developed into size-fractionating collectors (e.g. Monger et al., 1989; Collett et al., 1995), smaller versions such as the CASCC2 (Domez et al., 1996) or the mini-CASCC developed by Michna et al. (2013) that is powered by car batteries. The Caltech Heated Rod Cloudwater Collector (CHRCC; Collett et al., 1990) is a further developed version of the CASCC2 where the Teflon strings have been replaced by heatable stainless steel rods. Within those samplers, cloud

*Corresponding author. e-mail: paul.zieger@aces.su.se

Table 1. The operating and technical parameters of the miniaturised cloud water sampler (mini-CWS) compared to those of the CASCC2 and the CHRCC.

	mini-CWS	CASCC2	CHRCC
Inlet dimensions	13 × 13 cm	11 × 11 cm	11 × 11 cm
Strand diameter	0.560 mm	0.508 mm	3.175 mm
Number of rows	6	6	6
Fractional coverage per row	0.17	0.26	0.26
Sample flow speed	1.4 m s ⁻¹	8.6 m s ⁻¹	8.6 m s ⁻¹
Angle of inclination	35°	35°	35°
Weight	7 kg*	10 kg	10 kg

*The weight of the mini-CWS is given for the whole sampling kit including batteries and sensors, while the weights of the CASCC2 and CHRCC comprise only the samplers.

droplets are actively accelerated towards a sampling volume by a fan, where they impact on Teflon strings (or stainless steel rods for the CHRCC) and are collected in a sampling bottle situated below the cassette.

Cloud water collection for chemical analysis has been performed under a range of conditions at several locations, but there is only a very limited number of studies performed in extreme environments such as the polar regions. Due to the high power requirements of most samplers, previous studies have been limited to ground-based measurement sites in elevated mountain areas or passive sampling during aircraft measurements. Passive samplers bypass the problem of requiring access to electricity at the sampling site, but their cut-off diameter strongly depends on ambient wind speed and the samples might be contaminated by precipitation. To our knowledge, no balloon-borne active cloud water sampling has previously been performed. Due to the weight restrictions on tethered balloon systems, an extremely light-weight cloud water sampler had to be developed to enable active cloud water sampling within elevated clouds.

Since the chemical composition of cloud water can be used to infer the sources of those particles upon which cloud droplets and ice crystals form, obtaining high quality cloud water samples is an important goal. As such, we set out to develop a new light-weight cloud water sampler that would be able to sample on a tethered balloon within low-level clouds. First, we present and discuss the technical details and testing of the newly developed sampler. We further present preliminary results from a successful deployment and testing of the sampler in the high Arctic on board the Swedish icebreaker *Oden* and discuss the importance of careful sample handling.

2. Technical description

2.1. The miniaturised cloud water sampler

The miniaturised cloud water sampler (mini-CWS) developed during this study is a single-stage cloud water

collector based on the working principle of the Caltech active strand cloud water collector (CASCC2 and CHRCC, Demoz et al., 1996). Within such samplers, cloud droplets or ice crystals are actively accelerated towards a heated sampling volume by a fan (we used the DFB0912M model from Delta Electronics, Taiwan) where they impact on Teflon strings. Following impaction on the strings, the cloud water is collected in a sampling bottle situated below the string cassette. The strings are inclined to enhance droplet removal through aerodynamic drag.

The mini-CWS uses six rows of heated Teflon strings (Teflon tubes including a resistive heating wire) inclined at an angle of 35° for sample collection. The heating prevents excessive build-up of rime on the strings that could alter the collection efficiency and is only applied when the fan is turned off to minimise evaporation. To prevent ice accumulation on the sampler itself, resistors for heating (TO220 Radial 20 Ohms Resistors) are attached to the outside of the sampler walls and the funnel and are covered with insulation material and metal tape. A mesh of heated wires is placed downstream of the collection strands and upstream of the fan. The cloud water is collected in acid-washed brown Nalgene plastic sampling bottles (NALG2004-0002, Thermo Fischer Scientific, USA) situated below the string cassette. The protocol for acid-washing is given in Table S1 in the supplementary material. Opaque Nalgene bottles were chosen to prevent break-down of compounds or changes of the biological activity in the samples by UV-radiation and because they were most suitable for analysis of inorganic ions with ion chromatography (IC). The mini-CWS is operated by three lithium batteries (K2 Laptop Powerbank 185 Wh/50000 mAh, PowerOak, Netherlands) with a 12 V port to power the fan and a 20 V port to power the heating loop. The operating parameters of the mini-CWS are presented in Table 1 and a schematic of the mini-CWS is presented in Fig. 1. A fin is attached to the rear of

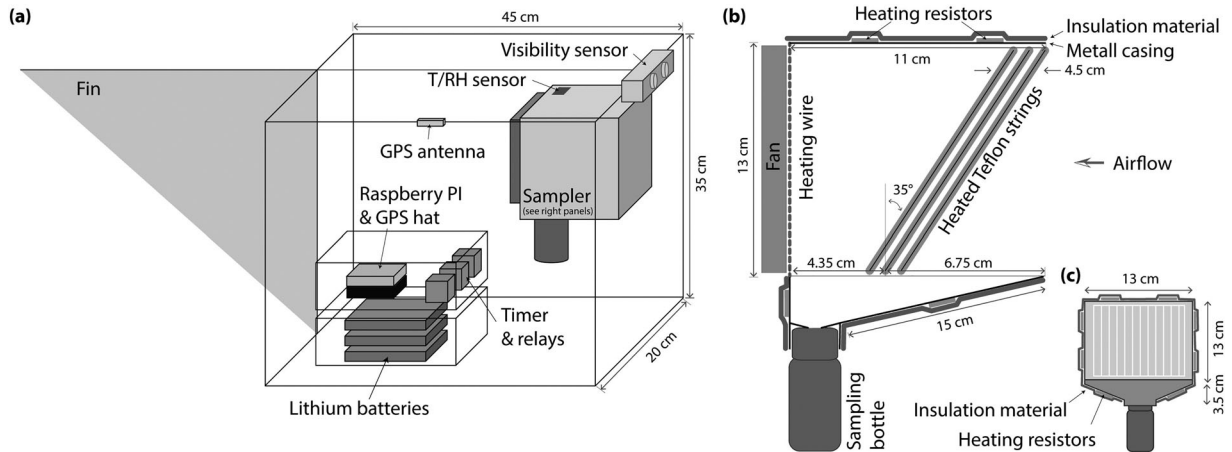

Fig. 1. Setup of the miniaturised cloud water sampler (mini-CWS). (a) Schematic of the mini-CWS which consists of the cloud water sampler unit, batteries, a data acquisition device, a timer with relays and sensors to measure temperature, humidity, visibility and GPS position. (b) Side view of sampler unit. (c) Front view of sampler unit. The Teflon strings are mounted in three sections with 6 rows in total.

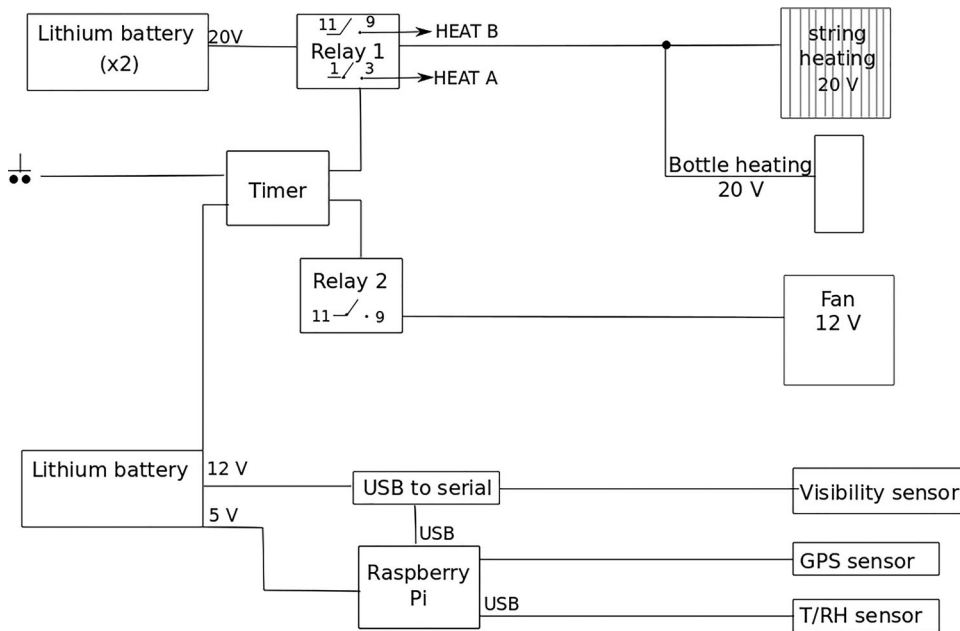

Fig. 2. Schematic circuit diagram of the mini-CWS.

the instrument to ensure that the sampler is always aligned into the wind. A miniaturised optical fog sensor (mini-OFS indoor version, Sten Löfving Optical Sensors, Sweden) was used to measure the visibility. This measurement was used to estimate both the time spent inside cloud and the thickness of the cloud. The visibility sensor is sensitive for visibilities between 0 and 500 m; if the visibility exceeds 500 m, the output is

limited to 5 V. In order to limit condensation on the receiver of the visibility sensor it was heated to a few degrees above ambient temperature. A low cost humidity and temperature sensor (TEMPerHUM RS485HUM, RDing Technology Limited Company, China) along with a GPS-antenna (GPM-03, Chang Hong Technology Co Ltd, Taiwan) and a corresponding GPS receiver (Raspberry GPS Hat Model MMP-

0203, Uputronics, United Kingdom) were connected to a computer (Raspberry Pi 3 model B, United Kingdom) to record temperature, humidity and location. A circuit diagram is depicted in Fig. 2 and an example of the data recorded during deployment can be seen in Fig. S1 in the [supplementary material](#). A timer (LT4H-W, Panasonic, Japan) was used to automatically switch between each active sampling and heating period. In the beginning of the campaign, the sampling period was set to 30 minutes, followed by 10 minutes of heating during which the fan was switched off to maximise melt-off of the accumulated ice. With decreasing temperatures throughout the campaign, the sampling period had to be adjusted to 15 minutes followed by an 8 minutes long heating period. An example of the heating cycle is presented in Fig. S1c in the [supplementary material](#).

2.2. Estimation of collection efficiency and collection rate

The droplet size sampling efficiency of the mini-CWS was estimated using the approach and equations given in Demoz et al. (1996). Factors that impact the collection efficiency of a CASCC2-type sampler are the surface area of the strings, the ratio of the cross-sectional area of the strings in a row to the cross sectional area of the sampler, the number of rows, the angle of inclination of the strings, strand diameter, droplet diameter, air viscosity as well as the turbulence of the flow which is dependent on the air speed and the presence of a flow straightener. Like the CASCC2 and the CHRCC, the mini-CWS does not have a flow straightener that assures a laminar flow and one therefore has to assume that the flow in the mini-CWS is turbulent. We cannot fully rule out acceleration effects in turbulent flow that could possibly reduce the impaction probability of droplets on the strings. However, due to the small size of our sampler, we believe the effect of acceleration losses to be negligible. Since the collection efficiency estimation of the mini-CWS is based on the same approach used for the CASCC2, which does not contain a flow straightener either, we assume our estimated collection efficiency to be representative. Michna et al. (2013) showed that an increase in strand diameter (for instance through rime accumulation) can potentially increase the collection efficiency. In addition to this, an increase in flow speed, e.g. through additional horizontal wind, can cause cloud droplets with smaller diameters to be sampled more efficiently. The volume of cloud water likely to be obtained during a typical deployment in the high Arctic can be estimated by multiplying the collection rate for different cloud liquid water contents (LWC, for a

more detailed derivation see Demoz et al., 1996) with the sampling time.

2.3. Sample handling

Following each deployment, the sample bottle was immediately returned to the laboratory (see Sect. 4.3) where it was weighed in order to determine the volume of cloud water sampled. Depending on the volume of cloud water sampled, subsamples were transferred into pre-cleaned plastic tubes that were acid-washed, using acid-washed plastic pipettes and analysed immediately.

To avoid contamination, the cloud water sampler was cleaned rigorously prior to each deployment. The cleaning process was designed to minimise contamination by inorganic ions, organic matter and bacteria, since these fractions were the subject of later analysis. Further, since the concentration of inorganic ions, organic matter and bacteria in the cloud water samples obtained was expected to be very low, an estimate of the background contamination originating from the sampler itself was required. To facilitate this estimate, handling blanks were obtained by collecting ultrapure deionised water (Millipore Alpha-Q, MQ, with a resistivity of 18 M Ω cm at 25 °C) using the sampler. To achieve this, an acid-washed spray bottle was used to spray the sampler strings with the ultrapure deionised water. Along with these handling blanks, the same ultrapure deionised water used to fill the spray bottle was also analysed before and after entering the spray bottle. This approach was used to exclude contamination of the water itself or of the spray bottle.

Acid-washing is usually used to remove contamination by organic matter. However, this approach could not be utilised to clean the mini-CWS, since the mounting of the strings contained metal parts and the funnel was entirely made of brass, which are both very reactive with acids. As such, a series of different cleaning procedures were tested to determine their efficiency for removing contamination. Following each of the approaches a new handling blank was obtained and subsequently analysed for its chemical composition or propensity to nucleate ice. A detailed overview of each the cleaning approaches used along with their respective handling blanks is given in Table 2.

As a result of this testing the following cleaning procedure of the strings and metal parts of the sampler was found to be optimal. Firstly, a rinse with ethanol (95% analytical grade, Solveco, Sweden) was used to remove organic matter contamination from both the strings and the metal parts of the sampler (e.g. the sampling funnel). Secondly, UV irradiation of the strings was applied to

Table 2. Cleaning procedures for mini-CWS and corresponding handling blanks.

Procedure	Cleaning procedure	Comments
I	Strings UV irradiated; thoroughly rinsed with MQ water; MQ water sampled from spray bottle	Respective procedure for sample collected on 17 August
II	Strings bathed in ethanol; rinsed with MQ water; MQ water sampled from spray bottle	Respective procedure for sample collected on 22, 24 and 25 August
III (final)	Strings bathed in ethanol; funnel cleaned with ethanol, clean room wipes and QTips; strings irradiated under UV (20 min each side); strings and funnel in ultrasonic bath of MQ water; MQ water sampled from spray bottle	Respective procedure for sample collected on 11 September

reduce contamination by bacteria. For this, the strings were irradiated for 20 minutes on each side in a vertical-laminar air flow cabinet (Mini V/PCR, Telstar, Spain) with a TUV 30 W 1SL/25 UV-lamp (Philips, Netherlands). Finally, the string cassette and funnel were rinsed with MQ water in an ultrasonic bath to remove remaining inorganic contaminants before being dried with particle free air/nitrogen in the laboratory.

The handling blanks collected during the expedition were compared with post-cruise instrumental blanks that were collected in the laboratory using the same cleaning procedures as described in Table 2 and the same equipment as during the campaign. Despite our attempts to recreate the same sampling conditions experienced during the expedition it is impossible for us to rule out that sources of contamination may have existed during the campaign that were not present during our later blank testing in the laboratory. The results of the comparison are discussed in Section 4.2.

3. Cloud water composition analysis

In this section we briefly describe the main analytical methods used to assess the background contamination of the sampler as well as the composition of samples collected during its first deployment in the high Arctic.

3.1. Ion chromatography

An ICS-2000 ion chromatography system (Thermo Fischer Scientific, previously Dionex) was used to determine the concentration of the major anions (Chloride, Cl^- ; Nitrate, NO_3^- ; sulphate, SO_4^{2-}), weak anions (methane sulphonate, CH_3SO_3^- , MSA) and cations (sodium, Na^+ ; ammonium, NH_4^+ ; potassium, K^+ ; magnesium, Mg^{2+} ; calcium, Ca^{2+}) in the samples. The method

is described in detail in Leck and Svensson (2015). Analytical quality checks were performed using certified reference samples. Random percentage errors, measured with a synthetic sample (QC Rainwater Standard, Inorganic Ventures, USA), were better than 1% for strong anions, 3% for weak anions and 3% for cations. Systematic errors as evaluated by Interlaboratory tests (EANET, 2008; MSA not included) with concentrations similar to the ones in this study were less than 2% for all ionic components (with exception for Mg^{2+} , with less than 3%).

The analytical lower limit of detection (LOD) was defined as three standard deviations of the blank divided by the slope of the standard curve and was found to be 0.075, 0.045, 0.015, 0.010, 0.015, 0.020, 0.055, 0.002 and $0.002 \mu\text{mol L}^{-1}$ for Na^+ , NH_4^+ , K^+ , Mg^{2+} , Ca^{2+} , Cl^- , NO_3^- , SO_4^{2-} and MSA CH_3SO_3^- , respectively. The limit of quantification (LOQ) was defined as ten standard variations of the blank divided by the slope of the standard curve and was found to be 0.250, 0.150, 0.050, 0.033, 0.050, 0.067, 0.183, 0.007 and $0.007 \mu\text{mol L}^{-1}$ for Na^+ , NH_4^+ , K^+ , Mg^{2+} , Ca^{2+} , Cl^- , NO_3^- , SO_4^{2-} and MSA, respectively.

3.2. Thermal desorption chemical ionisation mass spectrometry

The chemical composition of a subset of cloud water samples was analysed using thermal desorption chemical ionisation mass spectrometry (TDCIMS). The reader is referred to Lawler et al. (2014) for more details. Ultrapure MQ water was also analysed using the same approach to assess the instrument background. A detectable signal was defined if the background-corrected signals were two standard errors above background and the sums of the detected ions were background-subtracted.

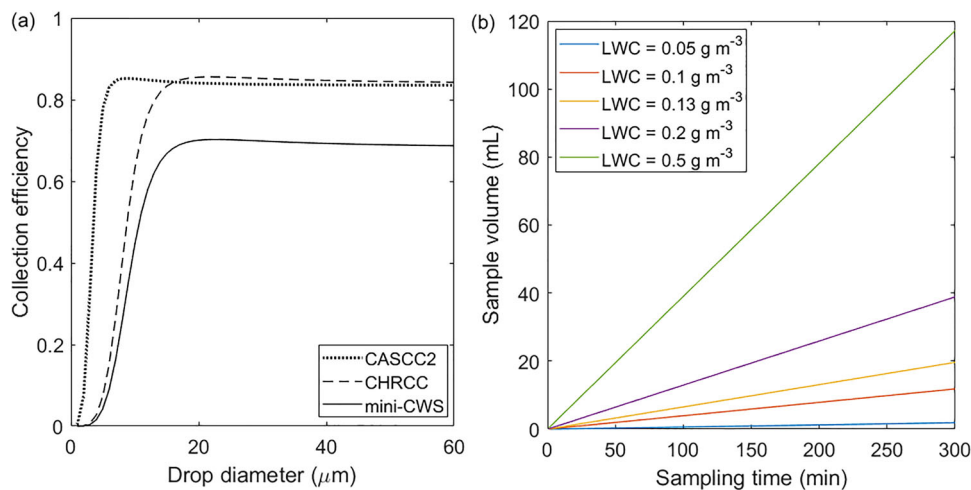

Fig. 3. (a) Theoretical collection efficiency of the mini-CWS compared to the CASCC2 and CHRCC (Demoz et al., 1996) based on their respective sampling velocities (1.4 m s^{-1} for the mini-CWS and 8.6 m s^{-1} for the CASCC2 and CHRCC) and (b) estimated sample volume for the mini-CWS for different LWCs.

3.3. Ice nucleating particle analysis

The cloud water samples were also investigated for their propensity to nucleate ice crystals. For the INP analysis, a microlitre Nucleation by Immersed Particle Instrument was used. Further details of this method are described in Whale et al. (2015). To assess whether protein based INPs were present in the cloud water samples some of the samples were heated to 100°C for 30 minutes prior to analysis (O’Sullivan et al., 2018). To reduce the possibility of changes in the samples, they were stored in a refrigerator at about 5°C for no more than 48 hours before analysis. Further, freezing of the samples prior to analysis was avoided.

4. Results

4.1. Collection efficiency and collection rate

By using the theory described in Demoz et al. (1996) (see Section 2.2), the droplet size sampling efficiency of the mini-CWS could be estimated and compared to the efficiency of a CASCC2 and CHRCC. Figure 3a shows the theoretical collection efficiency with respect to drop diameters of the mini-CWS in comparison to the CASCC2 and CHRCC based on the specifications given in Demoz et al. (1996). The 50% cut size, which is the droplet diameter collected with 50% efficiency, lies at $8 \mu\text{m}$ for the mini-CWS and the maximum efficiency for the mini-CWS of around 70% is reached at approximately $10 \mu\text{m}$. The lower collection efficiency of the mini-CWS compared to the CASCC2 and CHRCC could be explained by the smaller size and the lower flow velocity in the mini-CWS.

The ambient drop sizes that can be expected to be sampled for different LWCs according to the parametrisation of Best (1951) is displayed in Fig. S2 in the supplementary material. As an example, the Arctic atmosphere is rather dry (Kumai, 1973) where the LWC can be expected to remain below 0.1 g m^{-3} . Under these conditions, the sampler would be expected to yield a sample volume of slightly more than 10 mL for a sampling period of approximately 300 minutes (see Fig. 3b).

4.2. Assessment of background contamination

The inorganic ion concentrations of the handling blanks and the post-cruise instrumental blanks used to determine the background contamination are given in Table 3 along with the concentrations in ultrapure MQ water, bottle blanks, spray bottle blanks as well as the concentrations found in the cloud water samples. Neither the MQ water nor the sampling or spray bottle are significant sources of contamination. It can be clearly seen that the first handling blank collected on board the Swedish icebreaker *Oden* had substantially higher concentrations than the post-cruise instrumental blank with the same applied cleaning procedure. However, it should be considered that no sample was taken between the collection of the post-cruise instrumental blanks and the sampler was therefore not exposed to as high levels of contamination as during the expedition in the Arctic. Nonetheless, the concentrations in the first handling blank are also substantially higher than in the succeeding handling blanks which compare reasonably well to the post-cruise instrumental blanks (see also Fig. 4). This is probably due to contamination resulting from packing and shipping, since

Table 3. Concentrations of inorganic ions in the collected cloud water samples, handling blanks for different cleaning procedures (CP) that were taken during the expedition as well as mean concentrations in the reproduced (instrumental) blanks that were taken after the campaign, sampling bottle blanks, MQ blanks and a spray bottle blank. Furthermore, sample concentrations are compared to their respective handling blanks. N denotes the number of samples analysed.

Sample type	N	Concentrations ($\mu\text{mol L}^{-1}$)								
		CH_3SO_3^-	Cl^-	NO_3^-	SO_4^{2-}	Na^+	NH_4^+	K^+	Mg^{2+}	Ca^{2+}
Handling blank, 15 August, CPI	1	0.04	16.82	0.79	0.71	4.50	1.33	1.82	0.93	3.54
Handling blank, 21 August, CPII	1	0.01	1.60	0.24	0.16	1.31	1.51	0.74	0.20	1.35
Handling blank, 28 August, CPIII	1	0.01	1.70	0.21	0.11	1.47	1.15	0.62	0.20	0.77
Spray bottle blank	1	0.00	0.03	0.00	0.00	0.02	0.14	0.00	0.00	0.00
Bottle blanks	8	0.00	0.07	0.01	0.00	0.03	0.01	0.00	0.00	0.10
		± 0.00	± 0.04	± 0.02	± 0.00	± 0.06	± 0.01	± 0.00	± 0.00	± 0.09
MQ blanks	18	0.00	0.00	0.06	0.05	0.01	0.00	0.12	0.01	0.06
		± 0.00	± 0.00	± 0.12	± 0.20	± 0.01	± 0.00	± 0.44	± 0.04	± 0.13
Instrumental blanks, CPI (post-cruise)	6	0.00	0.87	0.57	0.27	1.35	0.20	1.20	0.36	1.49
		± 0.00	± 0.58	± 0.53	± 0.19	± 1.03	± 0.07	± 1.07	± 0.20	± 0.74
Instrumental blanks, CPII (post-cruise)	6	0.02	1.17	1.18	0.17	1.23	0.41	0.82	0.23	0.90
		± 0.03	± 0.48	± 0.96	± 0.09	± 0.83	± 0.13	± 0.92	± 0.09	± 0.45
Instrumental blank, CPIII (post-cruise)	6	0.00	0.43	0.31	0.10	0.53	0.22	0.41	0.10	0.52
		± 0.00	± 0.35	± 0.54	± 0.09	± 0.64	± 0.13	± 0.64	± 0.05	± 0.27
Cloud water, 17 August	1	2.77	33.49	8.98	9.12	24.77	6.88	10.40	4.73	8.34
Cloud water, 22 August	1	0.22	10.47	1.74	1.35	6.07	2.06	3.04	1.90	3.56
Cloud water, 25 August	1	0.41	14.03	3.48	1.70	13.21	2.28	3.21	2.22	3.33
Cloud water, 11 September	1	0.42	26.41	3.18	4.48	27.45	4.69	10.10	3.28	4.01
Ratio handling blank to sample										
Blank 15 August: Sample 17 August		0.01	0.50	0.09	0.08	0.18	0.19	0.18	0.20	0.42
Blank 21 August: Median of samples 22 and 25 August		0.029	0.13	0.09	0.11	0.14	0.70	0.24	0.10	0.39
Blank 28 August: Sample 11 September		0.02	0.06	0.07	0.02	0.05	0.25	0.06	0.06	0.19

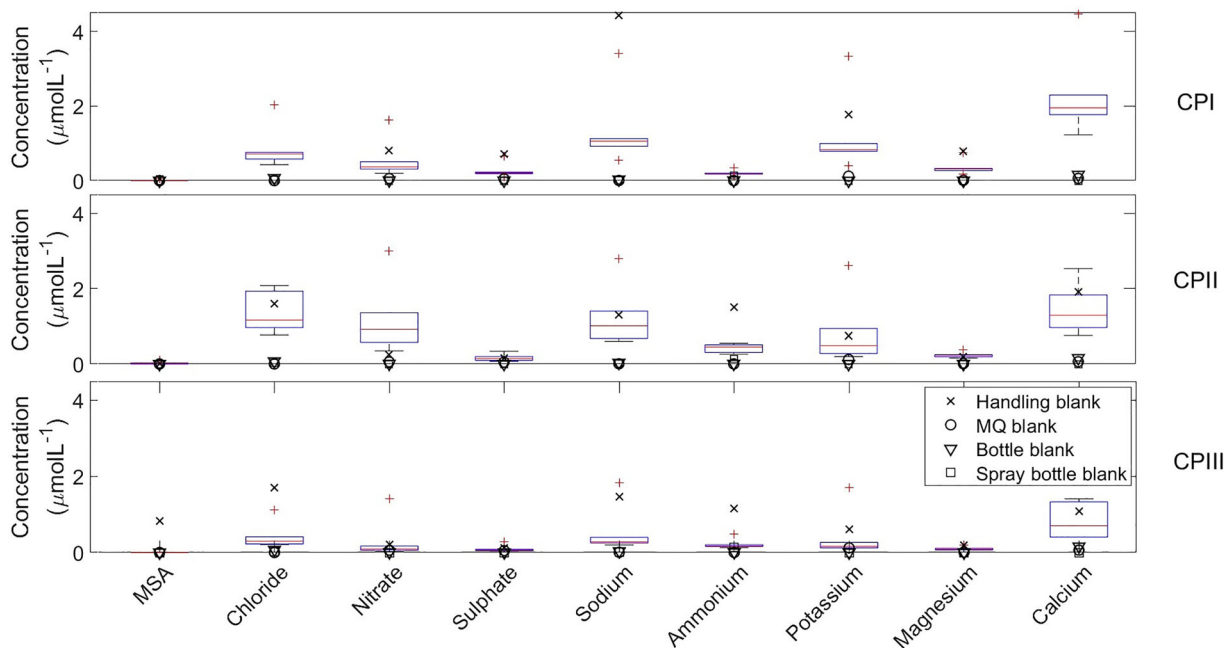

Fig. 4. Comparison of instrumental and handling blanks. Boxplot of instrumental blanks for the different cleaning procedures compared to the concentrations in the handling blanks (black crosses). Red crosses are outliers of the instrumental blanks.

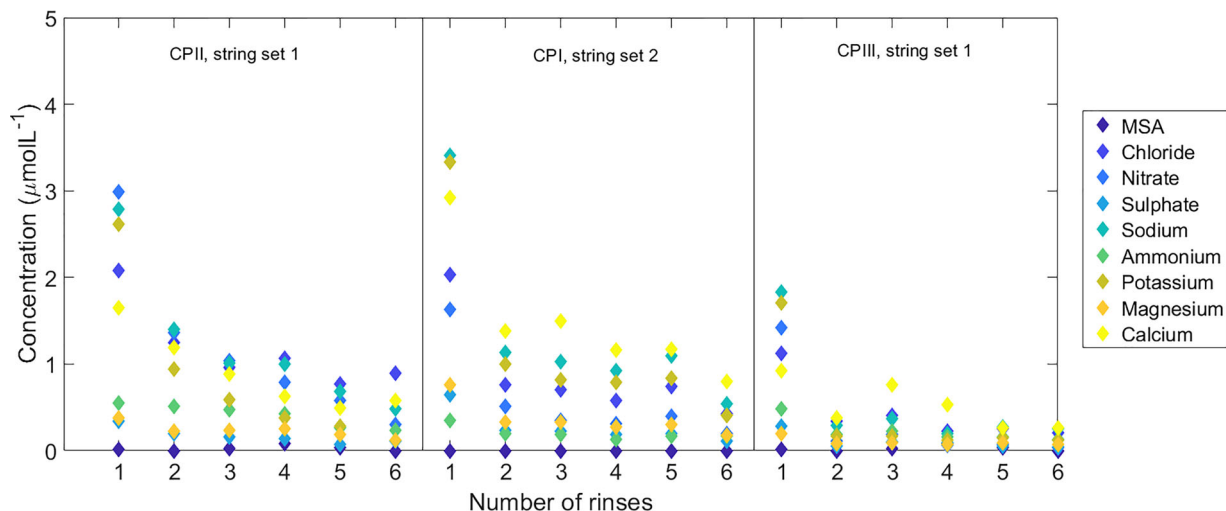

Fig. 5. Concentrations in post-cruise instrumental blanks for all cleaning procedures (CP) in dependence on the number of rinses.

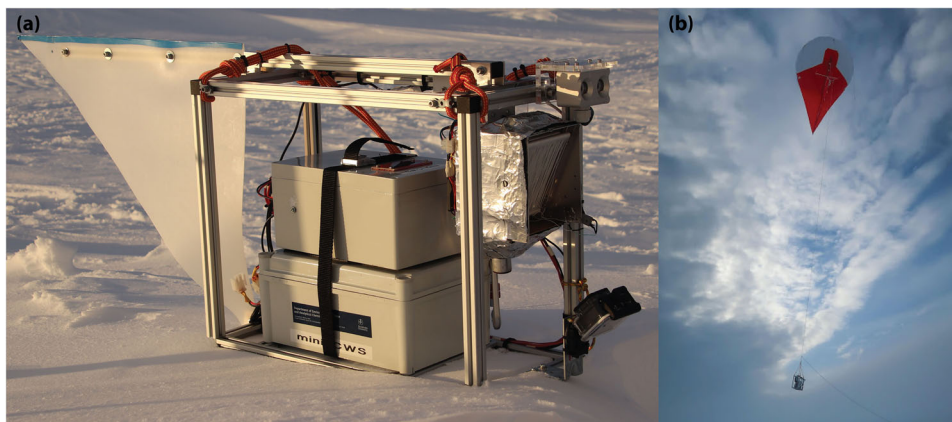

Fig. 6. Photo of (a) the instrument and (b) during the deployment on a tethered balloon in the high Arctic during the MOCCHA campaign.

it was the first blank to be collected after unpacking of the instrument and required thorough cleaning to be removed completely in the succeeding cleaning procedures.

Notably, the level of background contamination decreased almost exponentially as the number of rinses with ultrapure MQ water increased (this is shown in Fig. 5). After six rinses the concentrations were reasonably low (less than 10% of the concentrations in the samples for all inorganic ions except Ca^{2+} considering the first two cleaning procedures and only 1% for the final cleaning procedure CPIII, see Table 3). In fact, the number of rinses seems to be even more important for removing the inorganic background contamination than the different cleaning procedures that were applied. Further, it must be noted that the contamination seemed to be time

dependent. We suspect static deposition of aerosols from the room air to be a source of contamination on the strings of the sampler and would therefore recommend deploying the sampler immediately after cleaning (or to store it in a clean room/glove box) to minimise contamination on the strings by room air.

4.3. Results from a first deployment in the high Arctic

The mini-CWS was deployed during the Microbiology-Ocean-Cloud-Coupling in the High Arctic (MOCCHA) campaign on board the Swedish icebreaker *Oden* which was part of the Arctic Ocean 2018 expedition and took place in summer and early fall 2018 close to the geographic North pole. For five weeks, the icebreaker was

moored to an ice floe upon which an ice camp was installed. The mini-CWS was operated from a tethered balloon (SkyHook helikite, Allsopp Helikites Ltd, United Kingdom) installed on the ice floe (Figure 6 shows photos of the sampler during deployment in the Arctic). The balloon had a fabric keel that kept it oriented into the wind. The collection altitude of the samples, the sampling locations, the sampling times along with details of the analytical techniques subsequently applied to each sample are provided in Table S2 in the supplementary material. Limited by the dynamic lift of the helikite, sampling was bound to near-surface clouds in the lowermost 500 m of the atmospheric boundary layer.

All samples were bulk cloud water samples which were collected over several hours. The time in cloud was estimated for each deployment using the measured visibility. A visibility below 500 m was used as a threshold for determining when the instrument was within a cloud. This threshold was found to largely capture the fog water input by Burkard et al. (2003). An example of the recorded visibility data as well as sampling altitude relative to cloud base heights measured by a CL135 ceilometer (Campbell Scientific, United Kingdom) is depicted in Fig. S1 in the supplementary material. During two deployments, the batteries were fully discharged before the sampler was retrieved and as such the exact time spent in cloud is unknown. However, the measured times in cloud are still given in such cases, since they allow an estimate of the active sampling time within cloud. It is important to note though that those samples collected when the batteries were fully discharged may have been influenced by ice growth via riming on the strings. The rate of sample collection varied significantly across the different deployments (see also Table S2 in the supplementary material). In some cases very little sample was obtained, even though the sampler was in cloud for several hours, while other samples with higher volumes were obtained in a very short period of time. This highlights the influence of factors other than the sampler parameters on the obtained sample volume such as the cloud LWC and drop size distribution. In addition, it can not be excluded that icing on the strings as well as precipitation (e.g. blowing snow) might have contributed to the cloud water samples obtained.

The amount of sampled cloud water was often very low to the extent that sufficient sample volume for each of the different analysis techniques was rarely available. While the INP measurements and thermal desorption chemical ionisation mass spectrometry only required a few microlitres of sample volume, the ion chromatography required at least 2.5 mL. Given these constraints,

we were unable to apply all available analytical methods to each of the cloud water samples. It should be noted that all the analysis discussed here was performed on the ship during the expedition (except for the post-cruise instrumental blanks).

Table 3 provides an overview of the concentrations of the measured anions and cations obtained from IC analysis of the cloud water samples (before being corrected by the blank concentrations) that were collected on 17 August, 22 August, 25 August and 11 September compared to their respective handling blanks. It can be seen that the concentrations varied substantially between the samples and were in most cases dominated by the high concentrations of Na^+ and Cl^- , which originated from primary sea spray particles. The sample collected on 17 August contained a significant amount of NO_3^- , SO_4^{2-} , MSA, K^+ and Ca^{2+} that can be distinguished from the high concentrations in the handling blank. All concentrations discussed below have been subtracted by the concentrations in the respective handling blanks. The presence of Na^+ , Cl^- , SO_4^{2-} , MSA and Ca^{2+} indicates a marine source of aerosol. The sulphate may be present in the form of primary sea spray or may be the result of the atmospheric oxidation of dimethyl sulphide (Leck et al., 2002). The concentrations of non-sea-salt-sulphate (nss- SO_4^{2-}) can be calculated with the Na^+ concentration and seawater composition taken from Stumm and Morgan (1981): $\text{nss-SO}_4^{2-} = |\text{SO}_4^{2-}| - (0.063 \cdot |\text{Na}^+|)$. The blank-corrected nss- SO_4^{2-} concentrations were $7.1 \mu\text{mol L}^{-1}$ (constituting 85% of the total concentration), $0.9 \mu\text{mol L}^{-1}$ (75%), $0.8 \mu\text{mol L}^{-1}$ (51%) and $2.7 \mu\text{mol L}^{-1}$ (63%) for the 17 August, 22 August, 25 August and 11 September, respectively. In a similar manner the nss- Mg^{2+} and nss- K^+ concentrations were estimated as follows: $\text{nss-Mg}^{2+} = |\text{Mg}^{2+}| - (0.119 \cdot |\text{Na}^+|)$ and $\text{nss-K}^+ = |\text{K}^+| - (0.036 \cdot |\text{Na}^+|)$. The resulting nss- Mg^{2+} concentrations were $1.5 \mu\text{mol L}^{-1}$ (40%), $1.2 \mu\text{mol L}^{-1}$ (69%), $0.7 \mu\text{mol L}^{-1}$ (33%) and $0.14 \mu\text{mol L}^{-1}$ (5%) and the nss- K^+ concentrations accounted for $8.2 \mu\text{mol L}^{-1}$ (95%), $2.2 \mu\text{mol L}^{-1}$ (96%), $2.2 \mu\text{mol L}^{-1}$ (90%) and $8.93 \mu\text{mol L}^{-1}$ (94%) in the respective samples.

The TDCIMS was most sensitive to contamination and therefore detected high background levels in the blanks even when the other methods did not. The blank sample that was collected on 28 August was the first to be considered clean in the TDCIMS, which is why only samples collected after this handling blank are discussed below. Figure S3 in the supplementary material displays the detected ions in the blank sample and the cloud water samples that were collected after the final cleaning procedure was established. Only the sample collected on 11 September was analysed both with IC and TDCIMS.

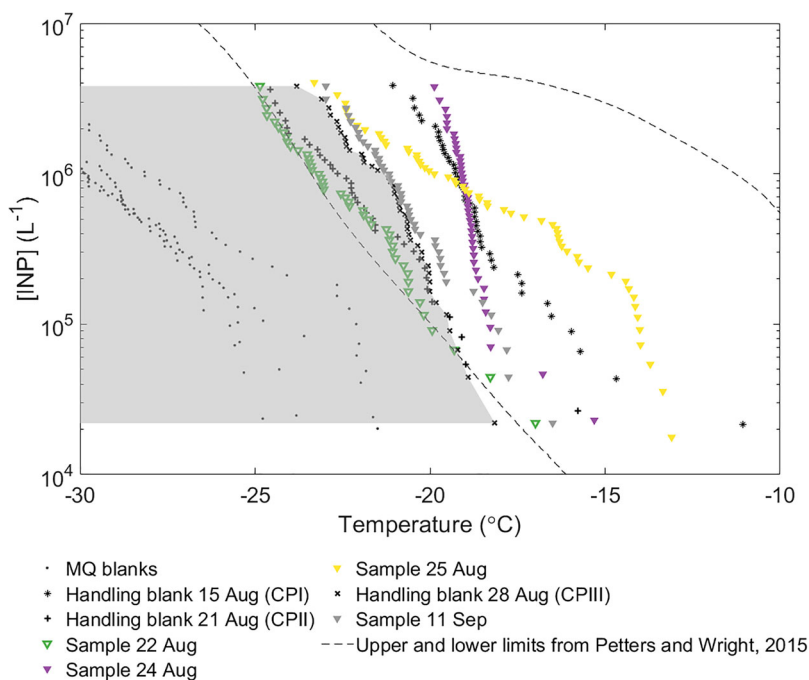

Fig. 7. Ice nucleating particle (INP) concentrations per litre of cloud water for collected samples, MQ blanks and handling blanks. The temperature denotes the freezing temperature of the individual droplets in the array of the INP analysis. The shaded area marks samples that fall below the baseline as set by the handling blanks, while the dashed lines show the upper and lower limits by Petters and Wright (2015). These samples are displayed with non-filled symbols and should be regarded as limiting values since they can not be discerned from the baseline.

The negative ion spectra of the samples were dominated by NCO^- (likely isocyanate), Cl^- , nitrite (NO_2^-), sulphur dioxide anions (SO_2^-) and iodide (I^-). The TDCIMS data appear to corroborate the high levels of salt detected in the IC analysis, with high levels of Cl^- and I^- in all samples. However, absolute signals of TDCIMS inorganic salt ions and organic ions cannot be used to infer relative ambient abundances of these species without calibration. In particular, electronegative species like I^- and NO_2^- are detected more efficiently than most organics. The detected SO_x^- ions are indicators for sulphur-containing salts. MSA was also detected. I^- is known to originate from either I^- or iodate (IO_3^-) salts and has been related to new particle formation in the past (Allan et al., 2015) and during this campaign (Baccarini et al., 2020). The NO_2^- ion is an indicator of NO_3^- in the particles that might be of inorganic or organic origin. Nitrate was also found in the IC analysis of the sample collected on 11 September, and TDCIMS-detected NO_3^- was highest on this day, so a significant fraction may be inorganic.

The positive ion spectra of the samples were dominated by $\text{C}_2\text{H}_5\text{O}^+$, the salt cations Na^+ and K^+ and a very wide array of organic peaks. $\text{C}_2\text{H}_5\text{O}^+$ has been identified as acetaldehyde and has been detected in marine aerosol before by Lawler et al. (2014). A substantial number of

reduced nitrogen compounds are present in the positive ion mass spectrum. Many of these that are likely to be biogenic in origin, e.g. peaks consistent with urea ($\text{C}_4\text{H}_8\text{N}^+$) and phenylalanine ($\text{C}_9\text{H}_{12}\text{NO}_2^+$).

The cumulative concentrations of INP per litre of cloud water in the collected cloud water samples, handling blanks and MQ blanks are shown in Fig. 7. Both samples and handling blanks started to freeze at higher temperatures than the respective MQ blanks, indicating that some contamination was introduced through the sampler. Only the samples collected on 24 and 25 August exhibited a detectable freezing signal above the blank background (e.g. at a temperature of -19°C , both samples had a factor of 11.5 higher INP per litre than the respective handling blank). One heat-treated sample showed indications of INP of biogenic origin (see Fig. S4 in supplementary information). The samples collected on 22 August and 11 September lie in or close to the baseline as set by the handling blanks. Therefore, it is not possible to discern the INP content in these cloud water samples from the background contamination.

One likely reason that handling blanks were considered clean by the TDCIMS but not the INP analysis is that the former is dependent on mass while the latter depends

upon numbers. The presence of only very few ice active particles can contaminate the INP blank which would have tiny mass that could not be seen in the TDCIMS. In future deployments further effort should be made to reduce the background contamination introduced by the sampler if the samples will be analysed with regards to their propensity to nucleate ice.

5. Conclusion

A miniaturised cloud water sampler with a cut-off diameter of approximately 8 μm and an overall collection efficiency of 70% was developed for balloon-operated collection of cloud water. The instrument is an active sampler that is based on the working principles of the Caltech active strand cloud water collector. It is heated to prevent excessive ice accumulation and is able to operate for several hours under the harsh weather conditions. The newly developed sampler was able to retrieve bulk cloud water samples under the challenging Arctic conditions experienced during the Microbiology-Ocean-Cloud-Coupling in the High Arctic (MOCCHA) campaign in August and September 2018. Due to the remoteness of the central Arctic Ocean and limited influence from long-range transported aerosol sources during summer and early autumn, the ionic concentrations observed in this study were expected to be very low. It was therefore of great importance to develop a suitable cleaning procedure to minimise background contamination by the sampler itself. The volumes that could be collected varied widely depending on time spent in cloud and the LWC of the cloud, but were also affected by riming or icing on the strings. The samples obtained were analysed by the same techniques used for aerosol measurements during the campaign. The preliminary results presented in this study facilitate a later comparison of the ship-borne sampling of ambient aerosols and clouds.

Acknowledgements

We thank Leif Bäcklin for his invaluable help in the construction of the instrument. We thank all helpers in the field, particularly Luisa Ickes and Karolina Siegel, for their invaluable assistance and help. Linn Karlsson (ACES) is thanked for providing the data acquisition software. We gratefully acknowledge Emmy Nilsson (MISU) for invaluable assistance with the ion chromatography analysis. We would like to extend our acknowledgement to Peggy Achtert for providing the ceilometer data and the Atmospheric Measurement Facility of the British National Centre for Atmospheric Science for providing the ceilometer. The Swedish Polar Research (SPRS) provided access to the icebreaker *Oden*

and logistical support. We are grateful to the SPRS logistical staff and to *Oden's* Captain Mattias Peterson and his crew.

Disclosure statement

No potential conflict of interest was reported by the authors.

Funding

This work was supported by the Swedish Research Council (grant no. 2016-03518, 2018-04255 and 2016-05100), the Swedish Research Council for Sustainable Development FORMAS (grant no. 2017-00567), the Knut-and-Alice Wallenberg Foundation (ACAS project, grant no. 2016.0024), the UK Natural Environment Research Council (grant no. NE/R009686/1), the Bolin Centre for Climate Research at Stockholm University, as well as the European Research Council (ERC, MarineIce: grant no. 648661).

Data availability

The data of this study is available on the Bolin Centre for Climate Research Database:

Julika Zinke, Emmy Nilsson, Luisa Ickes, Matthew Salter, Caroline Leck, Michael J. Lawler, Grace Porter, Michael Adams, Ian Brooks, Ben Murray, Paul Zieger (2021). Cloud water samples obtained in summertime during the Arctic Ocean 2018 expedition. Dataset version 1.0. Bolin Centre Database. <https://doi.org/10.17043/ao2018-cloud-water>

Supplemental data

Supplemental data for this article can be accessed [here](#).

References

- Allan, J., Williams, P., Najera, J., Whitehead, J., Flynn, M. and co-authors. 2015. Iodine observed in new particle formation events in the Arctic atmosphere during ACCACIA. *Atmos. Chem. Phys.* **15**, 5599–5609. doi:10.5194/acp-15-5599-2015
- Baccarini, A., Karlsson, L., Dommen, J., Duplessis, P., Vüllers, J. and co-authors. 2020. Frequent new particle formation over the high Arctic pack ice by enhanced iodine emissions. *Nat. Commun.* **11**, 1–11.
- Best, A. 1951. Drop-size distribution in cloud and fog. *Q. J. Royal Met. Soc.* **77**, 418–426. doi:10.1002/qj.49707733307
- Burkard, R., Bützberger, P. and Eugster, W. 2003. Vertical fogwater flux measurements above an elevated forest canopy at the Lägeren research site, Switzerland. *Atmos. Environ.* **37**, 2979–2990. doi:10.1016/S1352-2310(03)00254-1

- Collett, J., Iovinelli, R. and Demoz, B. 1995. A three-stage cloud impactor for size-resolved measurement of cloud drop chemistry. *Atmos. Environ.* **29**, 1145–1154. doi:10.1016/1352-2310(94)00338-L
- Collett, J. L., Jr., Daube, B. C., Jr. and Hoffmann, M. R. 1990. The chemical composition of intercepted cloudwater in the Sierra Nevada. *Atmos. Environ. Part A.* **24**, 959–972. doi:10.1016/0960-1686(90)90298-2
- Daube, B. C., Jr., Flagan, R. C. and Hoffmann, M. R. 1987. Active cloudwater collector. US Patent 4,697,462.
- Demoz, B., Collett, J. and Daube, B. 1996. On the Caltech Active Strand Cloudwater Collectors. *Atmos. Res.* **41**, 47–62. doi:10.1016/0169-8095(95)00044-5
- Hering, S. V., Blumenthal, D. L., Brewer, R. L., Gertler, A., Hoffmann, M. and co-authors. 1987. Field intercomparison of five types of fog water collectors. *Environ. Sci. Technol.* **21**, 654–663. doi:10.1021/es00161a006
- Kumai, M. 1973. Arctic fog droplet size distribution and its effect on light attenuation. *J. Atmos. Sci.* **30**, 635–643. doi:10.1175/1520-0469(1973)030<0635:AFDSDA>2.0.CO;2
- Lawler, M. J., Whitehead, J., O’Dowd, C., Monahan, C., McFiggans, G. and co-authors. 2014. Composition of 15–85 nm particles in marine air. *Atmos. Chem. Phys.* **14**, 11557–11569. doi:10.5194/acp-14-11557-2014
- Leck, C., Norman, M., Bigg, E. and Hillamo, R. 2002. Chemical composition and sources of the high Arctic aerosol relevant for cloud formation. *J. Geophys. Res.* **107**, AAC 1–1–AAC 1-17.
- Leck, C. and Svensson, E. 2015. Importance of aerosol composition and mixing state for cloud droplet activation over the Arctic pack ice in summer. *Atmos. Chem. Phys.* **15**, 2545–2568. doi:10.5194/acp-15-2545-2015
- Michna, P., Schenk, J., Werner, R. A. and Eugster, W. 2013. MiniCASCC – A battery driven fog collector for ecosystem research. *Atmos. Res.* **128**, 24–34. doi:10.1016/j.atmosres.2013.02.009
- Monger, J. W., Collett, J., Daube, B. and Hoffmann, M. R. 1989. Chemical composition of coastal stratus clouds: Dependence on droplet size and distance from the coast. *Atmos. Environ.* **23**, 2305–2320. doi:10.1016/0004-6981(89)90192-3
- O’Sullivan, D., Adams, M., Tarn, M., Harrison, A., Vergara-Temprado, J. and co-authors. 2018. Contributions of biogenic material to the atmospheric ice-nucleating particle population in North Western Europe. *Sci. Rep.* **8**, 13821. doi:10.1038/s41598-018-31981-7
- Petters, M. and Wright, T. 2015. Revisiting ice nucleation from precipitation samples. *Geophys. Res. Lett.* **42**, 8758–8766. doi:10.1002/2015GL065733
- Roman, P., Polkowska, Ż. and Namieśnik, J. 2013. Sampling procedures in studies of cloud water composition: A review. *Crit. Rev. Environ. Sci. Technol.* **43**, 1517–1555. doi:10.1080/10643389.2011.647794
- Skarżyńska, K., Polkowska, Ż., and Namieśnik, J. 2006. Sampling of atmospheric precipitation and deposits for analysis of atmospheric pollution. *J. Automat. Methods Manage. Chem.* **2006**, 1–19. doi:10.1155/JAMMC/2006/26908
- Stumm, W. and Morgan, J. J. 1981. *Aquatic Chemistry: An Introduction Emphasizing Chemical Equilibria in Natural Waters*. New York, USA: John Wiley & Sons.
- Whale, T. F., Murray, B. J., O’Sullivan, D., Wilson, T. W., Umo, N. S. and co-authors. 2015. A technique for quantifying heterogeneous ice nucleation in microlitre supercooled water droplets. *Atmos. Meas. Tech.* **8**, 2437–2447. doi:10.5194/amt-8-2437-2015