



Deposited via The University of Leeds.

White Rose Research Online URL for this paper:

<https://eprints.whiterose.ac.uk/id/eprint/157494/>

Version: Accepted Version

---

**Article:**

Abbas, RK, Ghanbarzadeh, A and Hassanpour, A (2020) A novel method for estimating the real-time dullness of tri-cone oil drill bits. *Engineering Failure Analysis*, 109. 104386. ISSN: 1350-6307

<https://doi.org/10.1016/j.engfailanal.2020.104386>

---

© 2020 Published by Elsevier Ltd. This manuscript version is made available under the CC-BY-NC-ND 4.0 license <http://creativecommons.org/licenses/by-nc-nd/4.0/>.

**Reuse**

This article is distributed under the terms of the Creative Commons Attribution-NonCommercial-NoDerivs (CC BY-NC-ND) licence. This licence only allows you to download this work and share it with others as long as you credit the authors, but you can't change the article in any way or use it commercially. More information and the full terms of the licence here: <https://creativecommons.org/licenses/>

**Takedown**

If you consider content in White Rose Research Online to be in breach of UK law, please notify us by emailing [eprints@whiterose.ac.uk](mailto:eprints@whiterose.ac.uk) including the URL of the record and the reason for the withdrawal request.

# A Novel method for estimating the Real-Time Dullness of Tri-cone Oil Drill Bits

Rafid K. Abbas<sup>1</sup>, Ali Ghanbarzadeh<sup>2</sup> and Ali Hassanpour<sup>3</sup>

<sup>1</sup> Chemical Engineering Department, Faculty of Engineering, , University of Al-Qadisiyah , Al-Diwaniya city, 58002, Iraq.

<sup>2</sup> School of Mechanical Engineering, University of Leeds, Leeds, LS2 9JT, UK

<sup>3</sup> Institute of particle science and Engineering, School of Chemical and Process Engineering, University of Leeds, LS2 9JT, UK .

## Abstract

It is vital to anticipate the durability of drill bits for all drilling operations to prolong the drilling processes and reducing economic losses. Many attempts have been made to handle this issue by assessing the parameter of specific energy of the bits generated during drilling along with well logs and geophysical analyses. Although these techniques could provide acceptable precautions of the dullness of bit cutters, lack of consideration of material properties of the rock and the bit is their main shortcoming which could result in misleading interpretations. The present study deals with the development of a wear model of Tri-cone bits based on the concept of three body abrasive wear taking into account two main factors , rock hardness and the hardness of the materials forming the Tri-cone drill bit. Other parameters that have significant effect are also considered such as weight on bit, penetration rate, rotation speed and the required time to penetrate an interval depth. In this research, the bit wear quantified by the new developed model is compared with the *in-situ* dullness of the drill bit for a number of wells being excavated in southern Iraq, where a reasonable agreement was observed. The present work could be extended on other oil wells and applied on other types of drill bits to confirm the validation of the new model.

Keywords: *bit tooth dullness; bit wear; drilling performance; three body abrasive wear; tri-cone bits.*

---

\* Corresponding author. Tel. No.: +964(07808466224)

E-mail address: [Rafid.Abbas@qu.edu.iq](mailto:Rafid.Abbas@qu.edu.iq)

## 1- Introduction

During the oil drilling operations, various sorts of tri-cone bits were used due to their efficiency and durability. Although, the manufacturing of the bit has a significant role for wear resistance, the type of the rock being drilled has a great influence on the bit dulling including the tooth and bearing. Tricone or roller-cone bits are well known for drilling hydrocarbon wells. These bits are divided into two main types; steel or milled tooth bits and Tungsten-Carbide (TC) or insert bits. The wear of the bit commences directly after starting drilling due to the abrasivity of the rock being drilled causing the life of the bit to be reduced.

A method which has used traditionally for assessing the bit dullness is the Specific Energy (*SE*). This technique must be applied along with another method such as well-logging and geological attempts.

Teale et al. [1] defined the Mechanical Specific Energy (*MSE*) as needed energy to destroy one unit of rock volume. Teale et al. [1] derived the following equation for the Mechanical Specific Energy (*MSE*):

$$MSE = \frac{Work\ done}{Volume\ of\ rock\ removed} = 6.896 \left[ \frac{W}{A_{bit}} + 120\pi \frac{N \cdot T}{A_{bit} \times PR} \right] \quad (1)$$

where *MSE* is obtained in units of MJ/m<sup>3</sup>, *A<sub>bit</sub>* is the bit surface area (mm<sup>2</sup>), *W* is the weight exerted on the drill bit, (N), *N* is the speed rotation (RPM), *PR* is the rate of penetration rate (m/hr) and *T* is the torque of the bit (N-m)..

This technique is considerably used for monitoring the status of the bit during drilling as it gives positive indications on when to pull out the bit from the wellbore. Wei et al. [2] and Wiśniowski et al. [3] suggested a new model of the mechanical specific energy to monitor the improvement of the penetration rate for pulsed-jet drilling. It was found that the major parameters to improve the rate of penetration in the new modified model of the mechanical specific energy are the borehole cleaning efficiency of the cuttings and varying the destruction strength of the rock. A new

modified advanced mechanical specific energy model was found by Chen et al. [4] for the case of horizontal and directional and drilling.

$$MSE = E_m \cdot W_b \cdot \left( \frac{1}{A_{bit}} + \frac{13.33 \cdot \mu_b \cdot N}{d_b \cdot PR} \right) \quad (2)$$

where  $E_m$  is the mechanical efficiency of the bit ,  $\mu_b$  is the bit specific coefficient of sliding friction:

$$W_b = W \cdot e^{-\mu_s \cdot \tau_b} \quad (3)$$

$$\mu_b = 36 \frac{T}{d_b \cdot W \cdot e^{-\mu_s \cdot \tau_b}} \quad (4)$$

where  $\mu_s$  is the friction coefficient of drill string ,  $\tau_b$  is the inclination of the bottom hole (rad).

In the previous mechanical specific energy equations, the hydraulic energy was not taken into consideration for monitoring the drilling efficiency, while it was found that it has a considerable influence even the complexity of its role within the equation of mechanical specific energy.

Mohan et al. [5] showed that the hydraulic energy has a great influence on drilling efficiency. The mechanical specific energy model was modified to include the effect hydraulic energy, but the developed MSE model is suitable for high pressure jet drilling and soft formation drilling.

Abbas [6] suggested a new proposed mechanical specific energy equation that relies mainly on rock resistance towards wear i.e. rock hardness along with the hardness of the materials that form the bit itself. The results of this new formula were compared with the results obtained from Rabia's equation [7]. The results of the new equation showed a good matching with the in-situ field bit wear obtained from bit records.

Dupriest et al. [8] found that during drilling the drill bits are only 30-40% efficient at their peak performance. Accordingly, the ( $MSE$ ) could be correlated with the compressive strength of the rock and would be nearly three times the rock compressive strength [1] and therefore, it should be adjusted by multiplying by factor from 0.3 - 0.4.

$$MSE_{cor.} = MSE \times EF \quad (5)$$

where  $MSE_{cor.}$  is the adjusted mechanical specific energy ( $\text{MJ/m}^3$ ) and  $EF$  is the correction factor (unitless). It was agreed that in most oil drilling operations a value of 0.35 is used regardless of the type of the drill bit [8].

Abbas *et al.* [9] have applied a combination of a bit tooth wear indicator along with specific energy for monitoring the dullness or wear of roller-cone drill bits during real-time drilling at various oil wells drilled by tri-cone bits in the South of Iraq region. The specific energy method showed a good indication of bit tooth dulling, however at certain depths there were differences in the trend between the *in-situ* wear of the bit tooth with the specific energy. Abbas *et al.* [9] attributed these incompatible trends between the two approaches to considerable important factors that were missing in the specific energy equations. These factors are mainly (i) the phenomenon of three body abrasion occurred on the cuttings of the rock being drilled producing a kind of motion free of these cuttings letting the rock cuttings to roll and slide, (ii) the materials that the bit consists of and (iii) the resistance of the rock against wear or hardness.

Jalal [10] used recently a new analytical model for achieving optimum drilling performance using the concept of the bit mechanical specific energy used in drilling function of real time bit dullness. The obtained model could help the drill engineers when is the proper time to pullout the worn bits. The new model solved multiple differential equations to anticipate the effective drilling efficiency.

Reitz and Paulo [11] proposed a new simulation model for real-time drill bit wear estimation. The model determined the real-time bit wear during the drilling operation by combining physical equations and with data mining. The new proposed simulation model estimated the bit wear for each section being drilled. The results of this new model showed a compatibility with the real data of bit wear provided from the field.

Rashidi *et al.* [12] demonstrated the degree of tri-cone bit insert dullness and the cutters wear of PDC bits based on the classification of the International Association Drilling Contractors (

IADC). Figure (1) shows that for a brand new bit cutter, the wear is nil, whereas a potential destructive bit has a degree wear of 1 or 8/8.

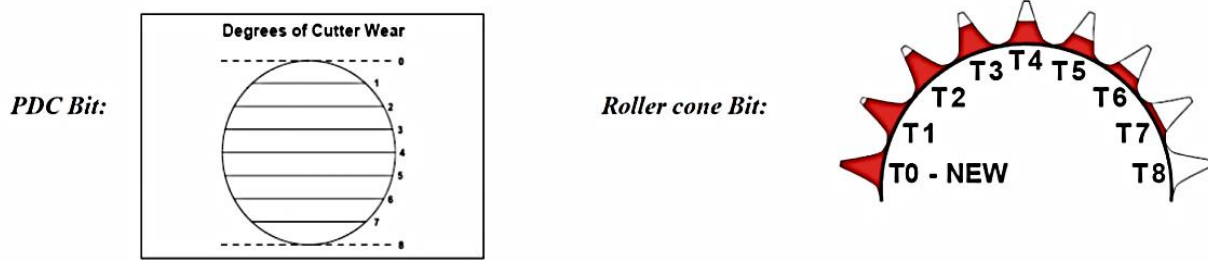

Figure (1) Wear grading system for bit tooth (insert) [12]

Abbas [13] reviewed the main proposed analytical wear models of oil and gas drill bits. The models were presented with some examples for their implication on the real drill bits. Abbas and Hassanpour [14] suggested a new formula for estimating the oil drill bit wear based on experimental tests of micro and nano-indentation, The study showed that the obtained experimental results of the samples being tested could be unified on a single sketch taking into consideration that three parameters have the most dominant influence on drill bit wear (load, sliding distance, and hardness).

Rabinowicz [15] and Rabinowicz et al. [16] studied the wear of three-body abrasion. They postulated a non-complicated mathematical model for the case of three body abrasive wear, where the wear rate in this situation is nearly ten times less than two-body abrasive wear. Despite the importance of the parameters states above and the role of third body abrasive particles, there is no wear model that considers the effects in drilling bit application.

The dominant wear mechanism for the drill bit is reported to be abrasive wear [17, 18]. Surface analysis and micrographs of the worn bits clearly show the abrasive wear mechanism along with the apparent grooves on the surface [17, 18]. It is known that over 4/5 of the earth’s crust is made of hard minerals that have potential abrasive characteristics. Developing a comprehensive wear model for drilling bits requires an extensive study on different mechanisms involved in the degradation of the materials of bits while drilling. However it is a reasonable approach to consider the most influential degradation mechanism and develop a model in this application and test the

model with the experimental results. Therefore developing an abrasive wear model for the wear of drill bits is reasonable since abrasion is the most common mechanism of the material degradation in this application.

Waughman *et al.* [19] mentioned that majority of previous performance models of drilling do not include the significant influence of rock hardness and the hardness of the bit used for drilling. The present paper overcomes this deficiency by using a new formula that combines the two crucially important parameters of rock and bit hardness. In addition, the new presented model involves drilling parameters such as the weight exerted on the bit, rotary speed, as well as the mechanical properties of the minerals that the bit consists of. The new formula that based on the principle of three-body abrasion is presented in Section 0-2.

In this work, the hardness of the rock being drilled and the hardness of the materials that form the bit could be obtained from bit records, well logs and literature. Rock lithology was collected from the research of Al-Ameri *et al.* [20]. The volume of rock being excavated as well as the volumes of the bit wear is calculated according to the fundamentals of three body abrasion suggested by Rabinowicz [15] which is explained in detail in Section 0. The qualitative bit wear defined as the ratio of the insert's worn height over the initial insert's height, is used as a surveillance indication of bit tooth dulling. The anticipated bit tooth dullness was compared with the *in-situ* bit tooth dullness or wear taken from bit records as good agreements were found.

## **2- Data collection**

The raw data from bit records are obtained from five oil wells in Southern Iraq (Basrah). The actual oil wells are referred to A<sub>1</sub>, A<sub>2</sub>, B<sub>1</sub>, B<sub>2</sub> and B<sub>3</sub>. The lithological information regarding the stratigraphic column of the wells of interest is found from the previous work of Al-Ameri *et al* [20]. Figure (2) shows the rock formations being drilled (lithology) in Basrah oil fields in South of Iraq.

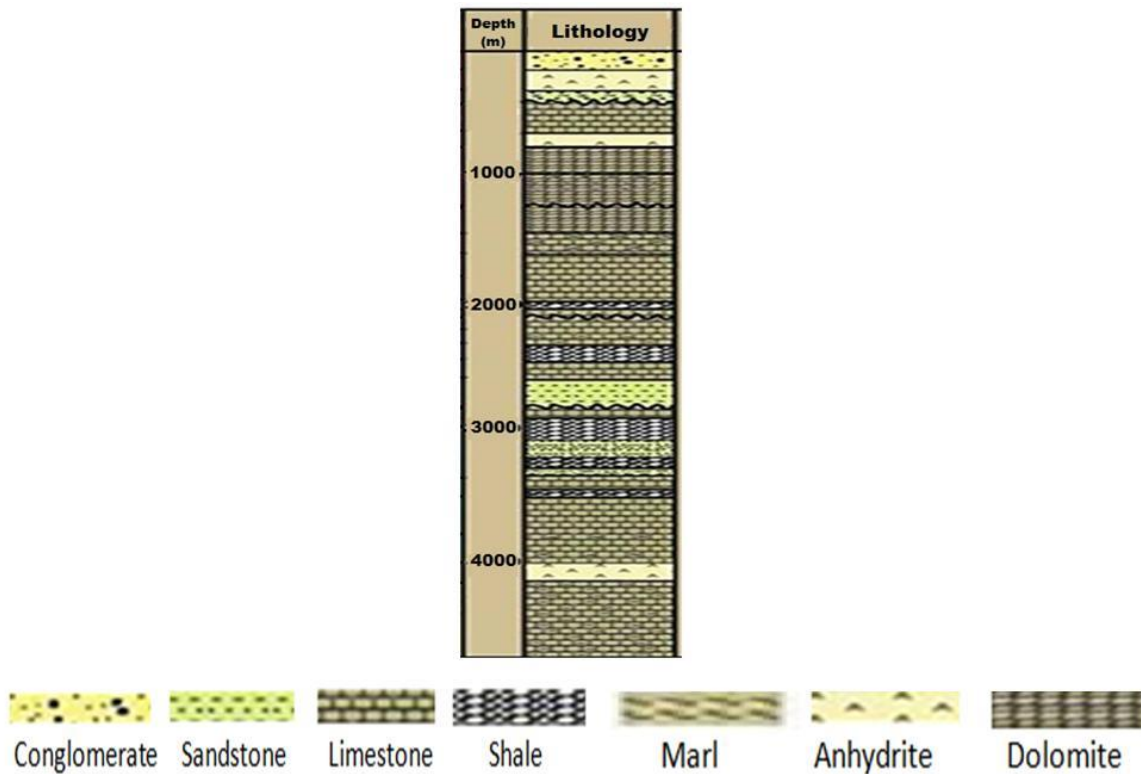

Figure (2) Lithological stratigraphic of rock formation in Basrah, Southern Iraq [20].

### 3- Theoretical background

#### 3-1 Theory of three body abrasive wear

There are different mechanisms known for wear of the materials, notably adhesion, abrasion, fatigue, corrosion and erosion. All these mechanisms occur in different interfacial conditions. There are however mechanistic models in the literature describing each mechanism as explained in Section 1. All these mechanisms somehow contribute in the degradation of the drilling bits [17]. However, the abrasive wear mechanisms seems to be dominant [17]. There are two main mechanisms of abrasion; two-body and three-body. It has been shown that distinguishing between these two abrasive modes of wear is very tricky [16]. There are important parameters that influence the transitions between these modes of wear such as the applied load and the concentration of the abrasive particles [21] but there still is not a comprehensive transition model describing the phenomena. Therefore it is not a straightforward approach to classify two-body and three-body modes of abrasive wear. During drilling operation the drill bit is in contact with rock formation which results in production of debris in form of particles of various sizes. This

phenomena is similar to grinding and the rock is converted to small particles or powders. These hard particles are surrounded by two rigid surfaces but these particles are free to roll and slide, a condition which resembles the three-body abrasive wear as demonstrated in Figure (3). In the drilling conditions, the drill bit is harder than the rock which is necessary for the rock to be crushed. In this case, a two-body abrasion is less likely to happen on the harder surface and is expected to occur on the softer material. Hence the occurrence of three-body abrasive wear is a possible dominant mechanism of material degradation on the drilling bit.

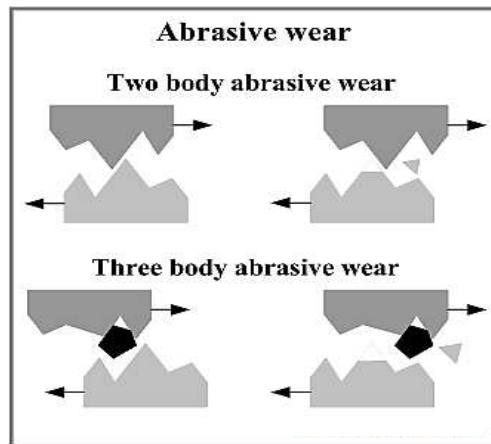

Figure (3) Comparison between (a) two-body abrasion and (b) three-body abrasive wear (Reprinted from Ref [22])

When the tri-cone drill bit is in contact with the rock formation, three body abrasion has the high possibility to occur during drilling, where the produced drill cuttings are found to be rolled and/slide.

### 3-2 Modification of Rabinowicz model

The present work aimed to quantify the bit tooth wear are based on the previous wear model of Rabinowicz [15] that depends mainly on the concept of three-body abrasion. Rabinowicz presented a formula for wear volume determination relies on the volume of the abrasive and the abraded materials as shown in Equation (6)

$$V_w = \frac{F \cdot \tan(\theta) \cdot X}{5.3 H_w} \left( \frac{H_a}{H_w} \right)^n \quad 0.8 < H_w/H_a < 1.25 \quad (6)$$

where  $V_w$  is the wear volume of the material being destroyed ( $m^3$ ),  $X$  is the sliding distance (m),  $F$  is the exerted load (N),  $\theta$  is the angle of abrasion ( $^\circ$  , see Figure 4),  $H_w$  is the hardness of the

abraded material (Pa) and  $H_a$  is the hardness of the abrasive material (N/m<sup>2</sup>). According to Rabinowicz's work [15],  $n = 2.5$ . However, in this study various power indices were used for later developments. This can result in finding the most appropriate indices for different applications in the future iteration of the model and enables parametric studies to be carried out.

In this study, it was found that the hardness of the rock being drilled is less than 10 GPa. However, at certain depth intervals, cemented sandstone is faced, which has higher hardness than 10 GPa (Al- Ameri *et al.*[20]. From the previous work of Mouritz and Hutchings [23], it was found that the hardness of tri-cone rotary drill bit tooth is ranged from 12.95 to 15 GPa.

The hardness of the rotary drill bits was measured by Mouritz and Hutchings [23], where it is nearly 1320 Vickers hardness number (HV) or equals to 12.95 GPa. This hardness represents the hardness of milled tooth tri-cone bit, whereas the hardness of the Tungsten Carbide (TC) bit is nearly 15 GPa. These values of bit hardness in general are greater than the hardness of the excavated rocks shown in Table 1 [23, 24].

The rock is considered as an abrasive material because of three-body abrasive particles, whereas the tri-cone drill bit is considered the abraded material. It was noticed that, the ratio of bit hardness over the rock hardness sometimes exceeds the value of 1.25 when excavating soft to moderate and formations.

In the study of Rabinowicz [15], there was insufficient information when  $H_w / H_a > 1.25$ , but it was mentioned that occurred wear is very small.

Equation (6) of Rabinowicz could be modified for the case of bit and rock as follows:

$$V_b = \frac{F \cdot \tan(\theta) \cdot X}{5.3 H_b} \left( \frac{H_R}{H_b} \right)^n \quad 0.8 < \frac{H_b}{H_R} < 1.25 \quad (7)$$

where  $H_b$  and  $H_R$  are the hardness of the bit and the rock (Pa), respectively, and  $V_b$  is the volume of the bit material being destroyed (m<sup>3</sup>).

Table 1 Main rock hardness being drilled in the present research[23, 24]

Rock formation type	Micro-hardness (HV)	Hardness (GPa)
Sandstone	1100*	10.79
Limestone	110*	1.079
Shale	250**	2.45
Dolomite	200**	1.961
Anhydrite	160**	1.569
Conglomerate (light calcite)	120**	1.17

\* Mouritz and Hutchings [23].

\*\* Gokhale [24].

In Equation (7), the sliding distance ( $X$ ) can be known from the following equation:

$$X = V_r \times t \quad (8)$$

where  $V_r$  is the bit linear velocity and  $t$  is the required time needed to excavate a certain section.

$$V_r = \pi N_b d_b \quad (9)$$

where  $N_b$  is the rotational speed of the bit and  $d_b$  is the diameter of the bit.

For roller-cone bits the conical inserts are mounted on the cones, therefore Equation (9) could be corrected as follows:

$$V_r = \pi N_{cone} d_{cone} \quad (9a)$$

The sliding distance could be determined from Equation (10):

$$X = (\pi N_{cone} d_{cone}) \times t \quad (10)$$

It is known that the time needed to drill a specific interval determined from Equation (11):

$$t = \frac{L}{PR} \quad (11)$$

where  $t$  the required time to drill a certain interval,  $PR$  is the rate of penetration and  $L$  is the depth interval excavated at a certain time.

It is worth mentioning that the exerted load ( $F$ ) in Equation (7) is corresponding to the weight on bit ( $W$ ). Therefore, substituting ( $W$ ) instead of ( $F$ ) in Equations (7) and substituting the time  $t$  in Equation (11) into Equation (10) produces a new equation as shown:

$$V_b = \frac{\pi \cdot W \cdot d_{cone} \cdot N_{cone} \cdot L \cdot \tan(\theta)}{5.3 PR \cdot H_b} \left( \frac{H_R}{H_b} \right)^n \quad (12)$$

Figure (4) illustrates the abrasive wear occurred when applying a conical probe assuming that the tip of the insert or cutter in a drill bit has a conical shape. Assuming the cross-sectional area ( $A_b$ ) of the insert being worn could be determined from Equation (13):

$$A_b = \pi \cdot r_i^2 \quad (13)$$

where  $r_i$  is the radius of the tooth cross section (m)

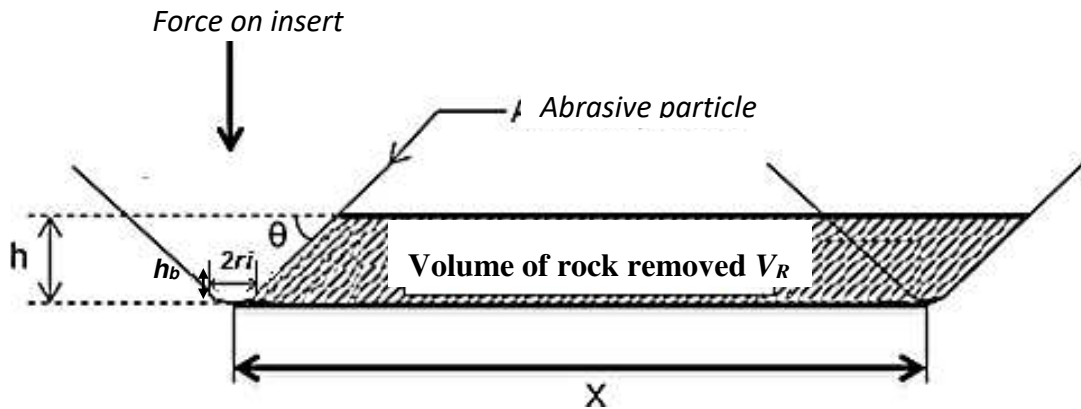

Figure (4) Modified model of bit tooth dullness (based on Rabinowicz [15])

The worn height of the tooth or insert ( $h_b$ ) can be determined from Equation (14).

where ( $\theta$ ) is the angle of abrasion as shown in Figure (4).

$$A_b = \pi \cdot \left( \frac{h_b}{\tan \theta} \right)^2 \rightarrow V_b = \frac{\pi}{3} \frac{h_b^3}{(\tan \theta)^2} \rightarrow h_b = \sqrt[3]{\frac{3 V_b \times (\tan \theta)^2}{\pi}} \quad (14)$$

where  $h_b$  is the height of the dulled volume of cutter or tooth (m) and  $V_b$  is the volume of the removed material from the bit ( $m^3$ ).

Hence, the ratio of dulled height of the cutter ( $h_b$ ) over the original tooth height is determined from Equation (15) assuming that the height of milled bit cutter is about (1.5 "), while the height of the TC bit insert is about (3/4") (Eason *et al.*,[25] ).

The anticipated qualitative wear of the bit insert which is in the grade between 0 and 8 grade is obtained as follows:

$$\text{Anticipated tooth qualitative wear} = \frac{h_b}{\text{Initial tooth height (h)}} \times 8 \quad (15)$$

The predicted wear rate of the bit insert or cutter could be then determined by dividing the anticipated wear of the insert over the depth being excavated.

In this study, the predicted wear rate obtained from Equation (15) is later compared with to the real-time *in-situ* wear of the cutter or insert.

It should be mentioned that when using Equation (12), the exponent index (2.5) is applied when the ratio  $H_b / H_R$  is less than 1.25. However, the ratio would be greater than 1.25 especially when excavating softer rocks. It is anticipated that the exponent index is higher than 2.5 (as less tooth dullness wear is anticipated).

The weight exerted on the bit is distributed on all cutters. Figure (5) shows how the exerted weight on bit is equal to the summation of the forces produced from the bit inserts or teeth [26].

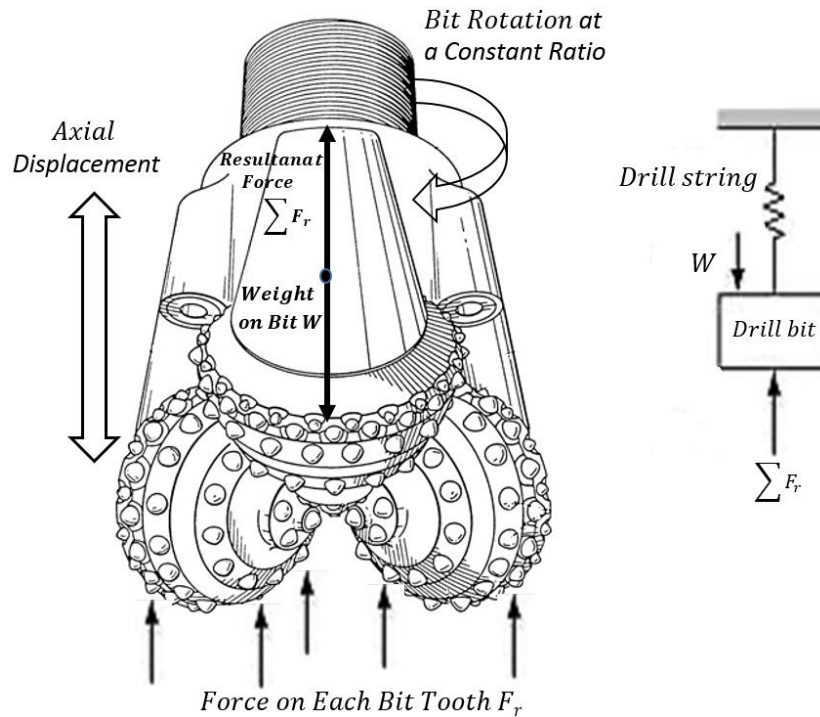
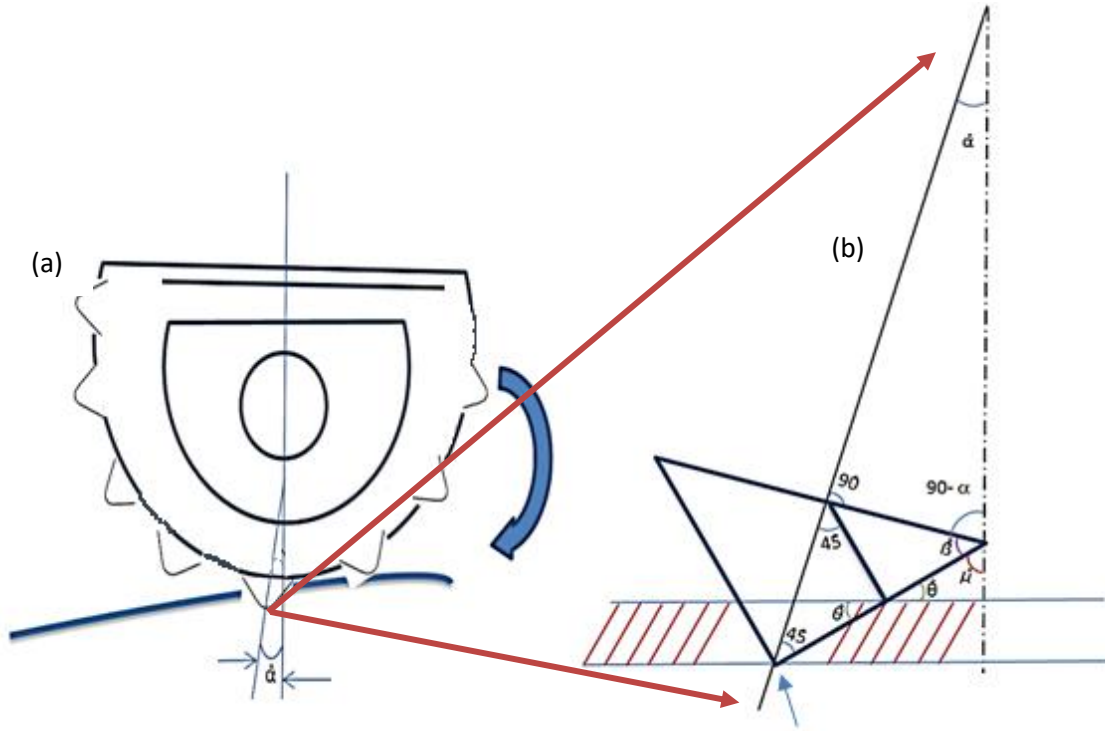

Figure (5) Forces affecting the tri-cone drill bit and the cutters [26,28]

Calculation of the volume of wear of each cutter or insert ( $V_i$ ), the weight on bit in Equation (12) should be distributed on the number of the cutters fixed on the bit's face. In general the frequency of the cutters for the tri-cone milled-tooth bit is usually less than TC bits), therefore to do the calculations, the number of the cutters for the tri-cone milled-tooth bit was estimated to be 50 and 65 for insert or Tungsten-Carbide (TC) bit. It is obvious that the assumed numbers of the cutters are varied.

In Equation (12), the abrasion angle ( $\theta$ ) could be represented in terms of another angle called the attack angle ( $\alpha$ ). The attack angle is defined as the angle between the cone axis and the intersection of the cutter centre line [26,27]. Figure (6a) displays the attack angle occurred between the drill bit and the rock being drilled. Figure (6b) shows a geometry sketch of the cutter being in contact with the formation being drilled.



the cutter contacted with

the rock formation [29]

The relation between the attack and abrasion angles from Figure (6b) will be:

$$\theta = 45^\circ - \alpha \quad (16)$$

$\alpha$  ranges between  $0^\circ$  and  $45^\circ$  [26,27] and therefore,  $\theta$  ranges between  $45^\circ$  and  $0^\circ$ .

Equation (16) could be substituted into Equation (12) where a new formula of the volume of bit tooth dullness is shown in Equation (17).

$$V_i = \frac{\pi (W/\text{no. of inserts}) \cdot d_{\text{cone}} \cdot N_{\text{cone}} \cdot L \cdot \tan(45 - \alpha)}{5.3 PR \cdot H_b} \left(\frac{H_R}{H_b}\right)^n \quad (17)$$

where  $V_i$  is the volume of tooth wear of the tri-cone bit ( $\text{m}^3$ ). It is worth mentioning, that the attack angle ( $\alpha$ ) in contact with the rock is ranging from  $0^\circ$  to  $45^\circ$ . The outcome of Equation (17) is regarded an incremental wear volume and it can be defined as follows:

$$V_i = \frac{d\mu}{d\alpha} \quad (18)$$

where  $\mu$  is full wear of an insert. In order to get a full rotation of the cutter. Abbas [29] mentioned that the integral in Equation (18) can be mathematically solved with respect ( $\alpha$ ) as follows:

$$\mu = \frac{\pi \cdot (W/\text{no. of inserts}) \cdot d_{\text{cone}} \cdot N_{\text{cone}} \cdot L \cdot \int_0^{45} \tan(45 - \alpha) d\alpha}{5.3 PR \cdot H_b} \left(\frac{H_R}{H_b}\right)^n \quad (19)$$

The result of the definite integral in Equation (19) is  $[\ln \cos(45 - \alpha)]_0^{45}$  is equal to 0.3465. The formula for estimating the insert wear could be written as:

$$V_i = \frac{0.205 (W/\text{no. of inserts}) \cdot d_{\text{cone}} \cdot N_{\text{cone}} \cdot L}{PR \cdot H_b} \left(\frac{H_R}{H_b}\right)^n \quad (20)$$

**The suggested wear model focused on the combination effect of drilling parameters and the physical properties of the rock and drill bit. This combination wasn't taken into consideration by previous models. However, future work to develop the proposed model by including the effect of the bit hydraulics is our aim.**

#### 4- Results and discussion

Table 1 illustrates the hardness of the excavated formations. Tri-cone bit type is determined from the classification charts of drills bits made by IADC. Materials that the drill bit is made from are determined depending on bit type and also from the information provided by McGehee *et al.* [30]. Roller tri-cone bit is either an insert bit (Tungsten-Carbide (TC)) or milled-tooth. The hardness of insert bit was selected to be 15 GPa, while for milled-tooth bit, the hardness is selected to be 12.95 GPa according to the material analysis of roller-cone bits (Mouritz and Hutchings [23]). Table 2 illustrates the commercial type of the drill bit used to excavate the rock formations of well A<sub>1</sub> in Southern Iraq corresponding to the drill bit manufacturer. Table 3 shows the rock formations being excavated with the corresponding hardness in GPa, along with the drilling parameters taken from the recent study of Abbas *et al.* [9].

From the provided data of all wells in the study, the volume of wear or dullness of the tooth (insert), ( $V_i$ ) is determined from Equation (20), while the height of the dulled tooth ( $h_b$ ) is calculated from Equation (14).

The anticipated wear index of the drill bit tooth (insert) is obtained from Equation (15) and later used to determine the insert dullness rate by dividing it over the incremental depth being excavated. The anticipated dullness rate of the bit cutters for each well is compared with the real-time *in-situ* tooth dullness rate taken from bit record data. The qualitative *in-situ* (tooth) wear rate is determined by dividing the *in-situ* tooth dullness ranging from 0 to 8 over the incremental accumulated depth.

Table 2 Tri-cone bits applied to drill well A<sub>1</sub> in South of Iraq [29]

Depth being excavated (m)	Tri-cone bit manufacturer	Commercial name of used tri-cone bits (code)	Type of tri-cone bits	Bit hardness (GPa)
0-38	HUGHES	SS5	Milled-tooth	12.95
38-660	HUGHES	R1	Milled-tooth	12.95
660-947	HUGHES	X3A	Milled-tooth	12.95
947-1440	TSK	MSS	Milled-tooth	12.95
1440-1530	SECURITY	M44NF	Milled-tooth	12.95
1530-1721	SECURITY	X3A	Milled-tooth	12.95
1721-1925	HUGHES	JD4	Milled-tooth	12.95
1925-2074	HUGHES	J4	Milled-tooth	12.95
2074-2440	SECURITY	S84F	(TC-bit)	15

Table 3 Drilling parameters of well A<sub>1</sub> in south of Iraq with the corresponding rock hardness [29]  
**Well A<sub>1</sub>**

After analysing the data for well A<sub>1</sub>, the anticipated tooth dullness (wear) rate is determined at various

Depth Drilled (m)	Rock Formation	Bit Diameter (in)	Weight on Bit (lb)	Rotational Speed (rpm)	Penetration Rate (m/hr)	Interval Drilled (m)	Time (hr)	Rock Hardness
0-38	Conglomerate	26	20000	100	6.33	38	6.003	1.17
38-660	Limestone +bit of Anhydrite	17.5	20000	100	5.78	622	107.61	1.25
660-947	Limestone	12 1/4	36000	70	4.94	287	58.097	1.079
947-1440	Dolomite	12 1/4	36000	75	6.36	493	77.515	1.961
1440-1530	Limestone	12 1/4	36000	75	4.5	90	20.00	1.079
1530-1721	Shale +Lime	12 1/4	36000	90	2.19	191	87.21	1.70
1721-1925	Limestone	12 1/4	36000	90	2.45	204	83.26	1.079
1925-2074	Shale +a bit of Lime	8.5	30000	100	3.5	147	42.00	2.20
2074-2440	Marl +Shale +Lime	8.5	30000	60	3.5	366	104.57	1.75

depths. Various power indices in Equation (12) were investigated and Figure (7) demonstrates the results of the real-time anticipated cutter dullness rate at different depth interval.

In Figure (7), it can be seen that the prediction is closer to the *in-situ* tooth dullness rate when the power index is equal to 2.5. However, when using values 3.0 and 3.5 power indices in Equation (20), the obtained dullness rate values are underestimated from the *in-situ* tooth dullness results at all depths. Even though, the

trend of the graphs shows a good agreement with the qualitative *in-situ* cutter dullness rate. In general, the overall graph trends determined from all various power indices in Equation (20) agree reasonably with the real-time *in-situ* insert dullness and illustrates the improvement of the anticipations as compared to the previous works [9]. Power indices less than 2.5 (1.5 and 2.0 in Equation (20)) were also investigated and the results are shown in Table 4, but the optimum power index to one decimal place was obtained to be the value of 2.5 obtained from the statistical analysis using Mean Absolute Percentage Error (MAPE).

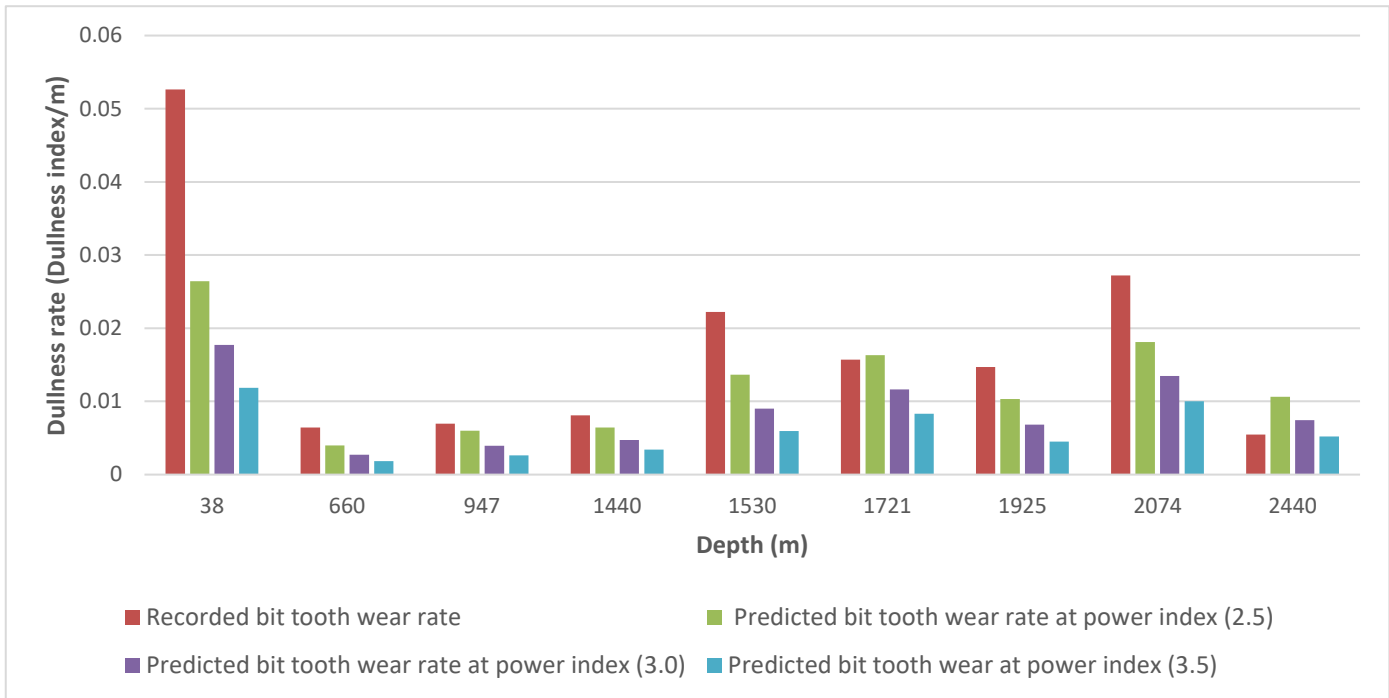

Figure (7) Real-time anticipated tooth dullness (wear) rate of various powers of equation (20) along with the real-time *field* bit tooth dullness rate for well A<sub>1</sub> in Basrah region South of Iraq

Same analyses were carried out for the rest of the wells. Accordingly, the optimum power index of the modified Rabinowicz equation could be determined.

Statistical analysis of Mean Absolute Percentage Error (MAPE) is used to determine the optimum power index in Equation (20). MAPE results are illustrated in Table 4. The statistical results showed the power index 2.5 gives the lowest value of MAPE, therefore the optimum exponent in Equation (20) for all wells is chosen to 2.5.

Table 4 Values of (MEPE) using various power indices values for wells A<sub>1</sub>, B<sub>1</sub>, B<sub>2</sub>, A<sub>2</sub> and B<sub>3</sub>

Well	(MAPE) Power index (1.5)	(MAPE) Power index (2.0)	(MAPE) Power index (2.5)	(MAPE) Power index (3.0)	(MAPE) Power index (3.5)
A <sub>1</sub>	332.22	198.85	<b>35.83</b>	48.30	58.55
B <sub>1</sub>	293.15	177.81	<b>26.72</b>	42.15	58.99
B <sub>2</sub>	426.11	262.67	<b>48.94</b>	41.54	50.00
A <sub>2</sub>	152.57	80.16	<b>48.82</b>	64.21	74.96
B <sub>3</sub>	292.64	173.9	<b>32.70</b>	44.25	60.87

From table 4 above, It is noticed that, well A<sub>2</sub> shows relatively high values of MAPE where the reason is explained later in the present research. The anticipated bit cutter dullness rates based on exponent index (2.5) for other wells are plotted and compared to the real-time *in-situ* tooth dullness rate.

### Wells B<sub>1</sub>, B<sub>2</sub>, B<sub>3</sub> and A<sub>2</sub>

Figure (8) demonstrates the plot of the anticipated insert dullness rate (when power index = 2.5) compared with the qualitative *in-situ* insert dullness rate for well B<sub>1</sub> at different depths. It is noticed that the anticipated dullness rate reasonably agrees with the qualitative *in-situ* tooth dullness rate at all depths, except slight divergence appeared from depth 1850 m to 2185 m. For well B<sub>2</sub> Figure (9) illustrates that the anticipated dullness rate agrees with the *in-situ* dullness rate, however overestimation of dullness rate was observed after depth 2561 m until depth 3009 m. The reason for that might be due to the existence of shale layers at the mentioned depth interval as shown in Figure (2) causing "bit balling" phenomena. In this situation the abrasive wear particles are accumulated in the shale and do not enter the contact interface thus reducing abrasive wear of the system. In addition, coverage of the shale on the bit acts as a solid lubricant and increases slipping over sticking as compared to the case the bit cutters penetrate into the rock. In addition, bit balling causes decreasing in rate of penetration (*PR*) at certain drilling parameters (constant weight on bit WOB and rotary speed N); accordingly overestimation of the anticipated dullness was obtained from Equation (20). Misinterpretation of the results might be caused due to the occurrence of shale formations where careful analysis should be carried out with such formations. In the case when shale formation is encountered, it is better to get benefit from other techniques for the anticipation of dullness such as well logs and geological data to prevent any misleading scattered results.

For wells A<sub>2</sub> and B<sub>3</sub>, as shown in Figures (10) and (12), the anticipated wear rate agrees in general with the anticipated real-time insert (tooth) dullness rate. However, at 1920 m for well A<sub>2</sub>, there is a significant under prediction of the dullness rate. It should be noted that for this well the geological formation has an unconformity structure at a depth of approximately 2000m.

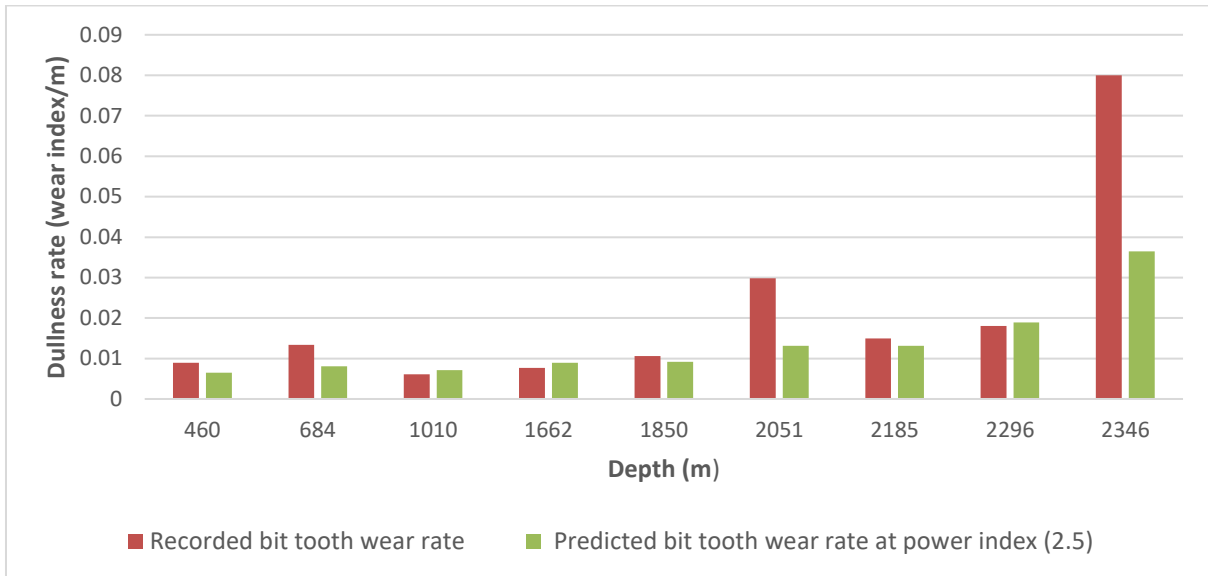

Figure (8) Anticipated dullness rate obtained from exponent index 2.5 compared with *in-situ* qualitative bit tooth dullness rate for well B<sub>1</sub>

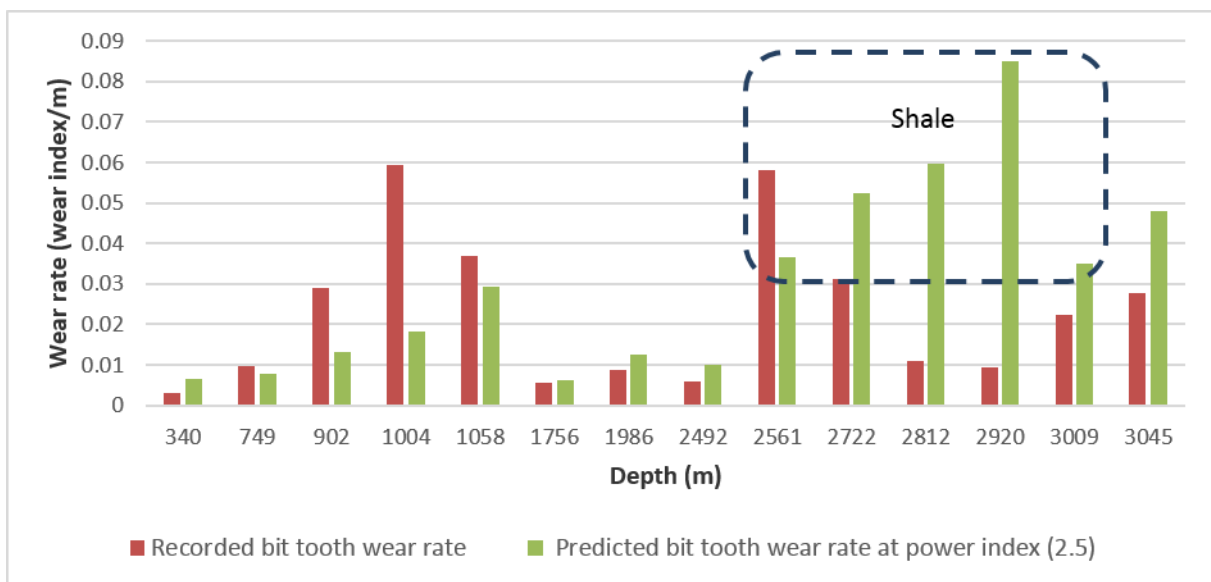

Figure (9) Anticipated real-time insert dullness rate obtained from exponent index 2.5 compared to the *in-situ* qualitative bit insert dullness rate for well B<sub>2</sub>

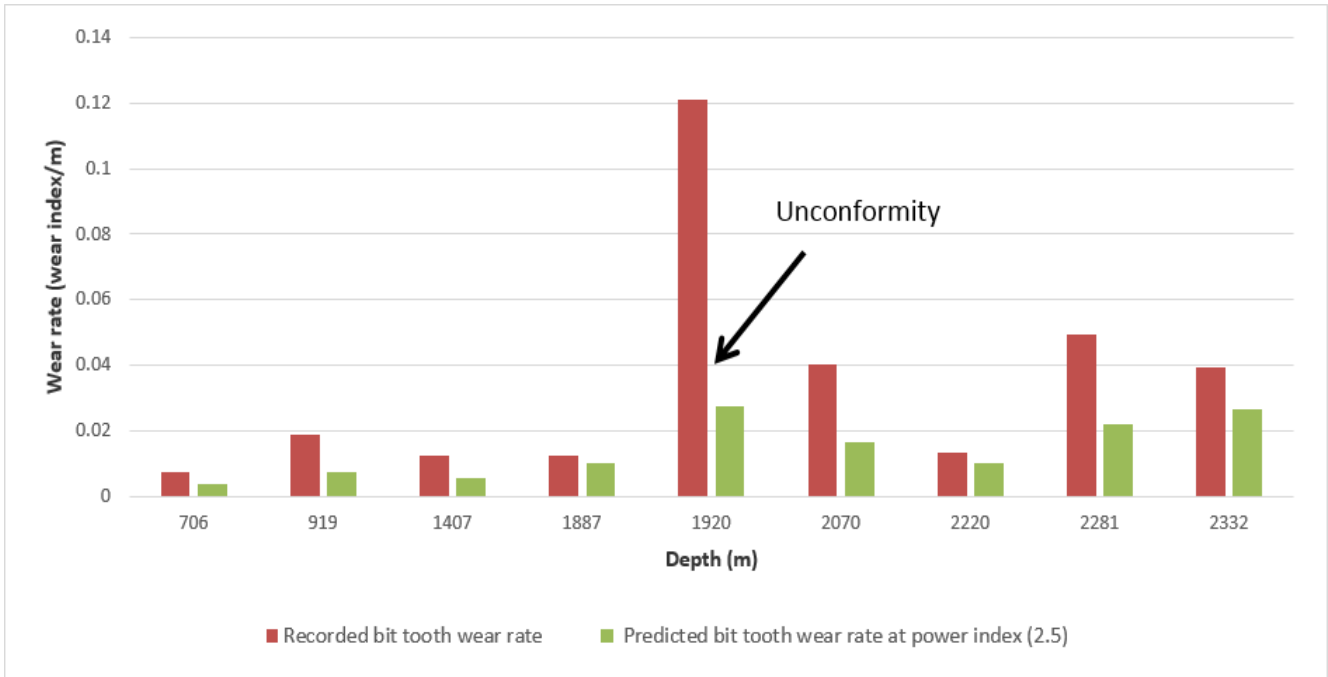

Figure (10) Anticipated bit tooth dullness rate compared with the *in-situ* qualitative bit insert dullness rate for well A<sub>2</sub> in south of Iraq

It is worth mentioning that, misleading results (high bit wear) might be attributed to the presence of shale and/or unconformity. Unconformity is caused by continuous sedimentation in a region producing the deposition of a sequence of parallel sedimentary layers in which the contacts between adjacent beds represent substantial gaps in time, in duration of thousands up to millions of years. When there is missing or interruption within the sediment parallel layers, this could lead to a type of unconformity called “disconformity” [31]. When drilling into formation in presence of unconformity, significant age gaps between rock formations result in substantial variation in their hardness (Figure 11) and this could lead to under prediction of bit tooth wear using Equation (20).

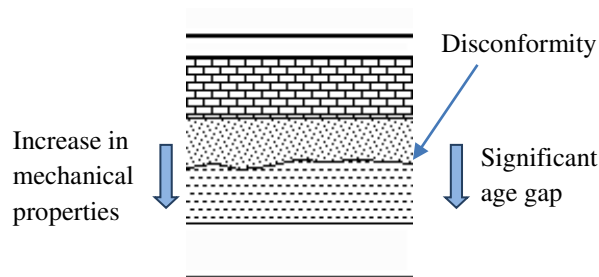

Figure (11) Development of disconformity [31]

For well B<sub>3</sub>, an over prediction of dullness was noted at depth 3264 m ,where a sharp increase of the ratio ( $H_R/H_b$ ) in Equation (20) from depth 3172 m to 3264 as seen in Figure (12). It is worth mentioning that, the reason for this overestimation of bit tooth wear rate might be attributed to the presence of sandstone within the shale formation. Hence, the hardness of the rock contains shale rose from 2.4 GPa at 3172 m up to 6.5 GPa at 3264 m. However, this occurrence is also accompanied by the bit balling phenomenon due to the existence of shale, which led to a sudden drop in the penetration rate for this well from 2.64 (m/hr) at depth 3172 m to 0.99 (m/hr) at depth 3264 m due to the same reason as explained earlier for well B<sub>2</sub>. This further increased the predicted wear rate at this particular depth, as expected from Equation (20).

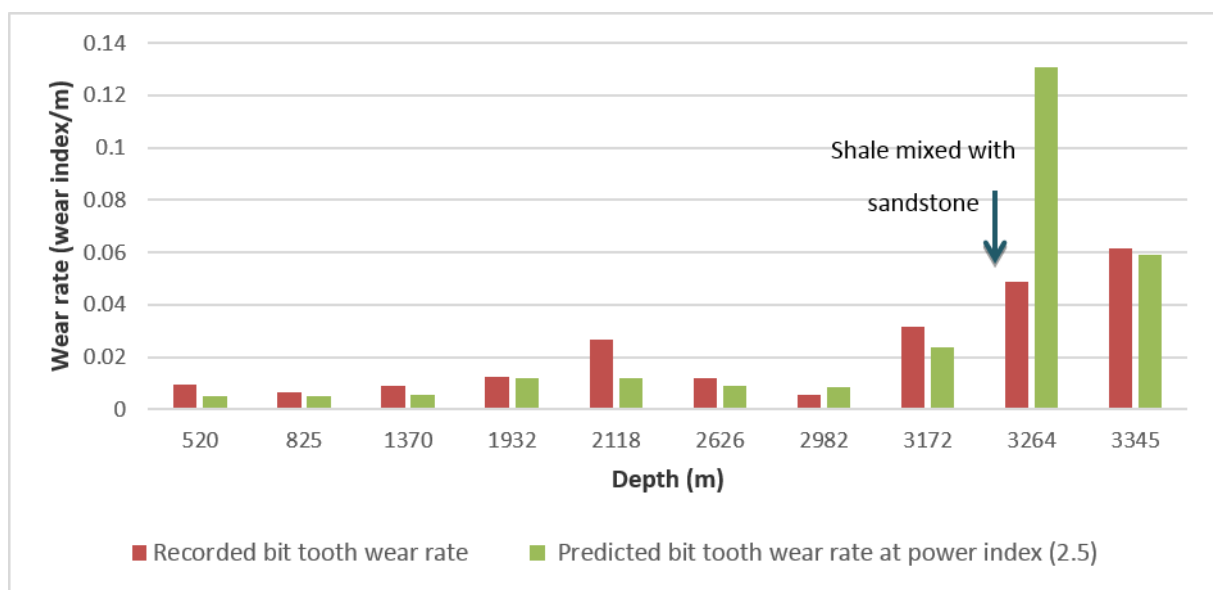

Figure (12) Real-time anticipated dullness rate compared with the real-time *in-situ* qualitative bit tooth dullness rate for well B<sub>3</sub>

### 5- Conclusions

Rabinowicz wear model was modified and developed for the prediction of the roller-cone bit tooth wear rate relied on the principle of three body abrasion. The new formula of bit tooth dullness incorporates the hardness of the materials that form the tri-cone bit and the hardness of rock being excavated along with other bit record information such as rate of penetration, rotational speed and the weight exerted on the bit. The new modified formula was applied on five selected wells in Basrah region South of Iraq. The results were compared to the real-time *in-situ* bit cutter dullness rate, where acceptable agreement at various depths was observed.

To sum up, the new modified model agrees reasonably with the qualitative in-situ bit tooth dullness for all wells being studied in this research, despite of minor anomalies, which were mostly due to drilling into shale formations causing bit balling phenomenon. Some discrepancies also occurred at certain depths due to the disconformity between the parallel layers causing misleading results. This has been an initial attempt to incorporate mechanical properties of rocks and bit for the wear prediction in oil well drilling. However, the prediction can be further improved by implementing more tribological behaviours such as lubrication by shale (accounting for the bit balling phenomenon) and effect of drill mud lubrication as well as more accurate characterisation of mechanical properties of different layers of rocks in order to capture the disconformity phenomena. Furthermore advanced well-logging tools could be used along with the predictive methods when encountering such geological structures to avoid misleading interpretation.

This approach could be applied to other wells with different formations for vertical wells, and further developed and extended to horizontal drilling. The wear model in this work is developed for milled tooth bits and it can be extended to be applied on Polycrystalline Diamond Compact Bits (PDC), where further work is needed to be carried out.

**It is worth mentioning, that the new suggested model is developed to predict the wear of the bit tooth only. The wear of the bearings is not relied on the bit tooth wear; therefore future work could study the failure of the bearings separately and combined it with the wear of the tooth wear of the drill bit to obtain an wear model of the whole bit (tooth and bearing). However, most of the bearings of the drill bits are auto-sealed which reduce the failure of the bearing not like the cutters (tooth) which are likely subjected to be worn more quickly and that's why the prediction of the bit tooth is essential to pull out the bit to avoid drilling problems and wasting the time and money.**

**In addition, The proposed model is applicable for drill bits where the action of the cutting is penetrating or breaking the rock in which it has the combination of grinding and shearing cutting action, therefore the new proposed model could be applied to PDC bits. The new developed model is validated on various roller-cone bits used to drill five oil wells in south of Iraq.**

**Furthermore, The suggested wear model focused on the combination effect of drilling parameters and the physical properties of the rock and drill bit. This combination wasn't taken into consideration by previous models. However, future work to develop the proposed model by including the effect of the bit hydraulics is our aim.**

## ***Nomenclature***

$A_b$	cross- sectional area of the insert, ( $m^2$ )
$A_{bit}$	area of the drill bit ( $mm^2$ , $m^2$ )
$A_{critical}$	critical area of the worn insert, ( $m^2$ )
$d_b$	bit diameter (m)
$EF$	correction efficiency factor (-)
$E_m$	mechanical efficiency of the bit
$F$	applied load (N)
$H_a$	hardness of the abrasive body (Pa), (GPa)
$H_b$	bit hardness (Pa), (GPa)
$H_R$	hardness of the rock formation (Pa), (GPa)
$H_w$	hardness of the abraded body (Pa), (GPa)
$HV$	Vickers hardness
$h$	height of milled bit cutter (m)
$h_b$	height of the dulled insert (m)
$L$	depth interval being drilled (m)
$MSE$	mechanical specific energy ( $MJ/m^3$ )
$MSE_{cor}$	corrected mechanical specific energy ( $MJ/m^3$ )
$N$	rotational speed (RPM)
$n$	power of the ratio ( $H_R/H_b$ )
$PR$	rate of penetration (m/hr)
$r$	radius of the drill bit (m)
$r_i$	radius of the insert (m), (cm)
$SE$	specific energy (psi)
$T$	bit torque (lb-ft)
$TC$	tungsten-carbide bit
$V_b$	volume of material removed from the bit, ( $m^3$ )
$V_w$	volume of wear removed from the abraded material, ( $m^3$ )
$V_i$	volume of the worn insert, ( $m^3$ )
$V_R$	volume of removed rock ( $m^3$ )
$V_r$	linear velocity (m/sec), (m/min)

$W$	weight on bit (N)
$X$	sliding distance (m)
$\alpha$	attack angle (0-45° )
$\theta$	abrasion angle (45-0° )
$\mu$	full wear of an insert, (m <sup>3</sup> )
$\mu_b$	bit specific coefficient of sliding friction.

### **Acknowledgments**

The first author is grateful for the support provided from the University of Al-Qadisiyah, Iraq. The first author is really indebted to Dr Ali Hassanpour for his supporting and encouragement provided throughout the research.

## References

- [1] R. Teale, The concept of specific energy in rock drilling, *International Journal of Rock Mechanics and Mining Sciences & Geomechanics Abstracts*, Elsevier, (1965) 57-73.
- [2] M. Wei, Li, G., Shi, H., Shi, S., Li, Z., and Y. Zhang, *Theories and Applications of Pulsed-Jet Drilling With Mechanical Specific Energy*. Society of Petroleum Engineers, 2016.
- [3] R. Wiśniowski, Dariusz K. and Ł. Hytroś \_Drillability and Mechanical Specific Energy analysis on the example of drilling in the Pomeranian Basin. *AGH Drilling , Oil, Gas*, 32 (1), 2015, 211-219.
- [4] X. Chen , Deli Gao , Boyun Guo and Yongcun Feng, Real-time optimization of drilling parameters based on mechanical specific energy for rotating drilling with positive displacement motor in the hard formation, *Journal of Natural Gas Science and Engineering* , 35 (2016 ) 686-694.
- [5] K. Mohan, Adil, F. and R. Samuel, Comprehensive hydromechanical specific energy calculation for drilling efficiency. *Journal of Energy Resources. Technology*, 137 (1), 2015.
- [6] R. Abbas, Superintendence of Bit Dullness Using a New Technique for Nasriya Oil Wells, *Journal of University of Babylon*, 25(2), 2017, 579-592.
- [7] H. Rabia, Specific Energy as a Criterion for Bit Selection. *SPE Journal of Petroleum Technology*, 37(7), 1985, 1225-1229.
- [8] F.E. Dupriest, W.L. Koederitz, Maximizing drill rates with real-time surveillance of mechanical specific energy, *SPE/IADC Drilling Conference*, Society of Petroleum Engineers, 2005.
- [9] R.K. Abbas, A. Hassanpour, C. Hare, M. Ghadiri, Instantaneous Monitoring of Drill Bit Wear and Specific Energy as a Criteria for the Appropriate Time for Pulling Out Worn Bits (Russian), *SPE Annual Caspian Technical Conference and Exhibition*, Society of Petroleum Engineers, 2014.
- [10] A.Jalal Al-Sudani, Real-time monitoring of mechanical specific energy and bit wear using control engineering systems, *Journal of Petroleum Science and Engineering*, 149 (2017) 171-182.
- [11] R. Reitz and Paulo. F Real-Time Simulation Method Using Monte Carlo and Clustering Algorithms: A Case Study Covering Drill Bit Wear, *Journal of Computer Science*, 14 (2), 2018.
- [12] B. Rashidi, G. Hareland, R. Nygaard, Real-time drill bit wear prediction by combining rock energy and drilling strength concepts, *Abu Dhabi International Petroleum Exhibition and Conference*, Society of Petroleum Engineers, 2008.
- [13] R. Abbas, A review on the wear of oil drill bits (conventional and the state of the art approaches for wear reduction and quantification), *Engineering Failure Analysis*, 90 (2018) 554-584.
- [14] R. Abbas, and A. Hassanpour, Evaluating the wear of polycrystalline diamond compact drill bit cutters using indentation and scratch tests, *ARO-The Scientific Journal of Koya University*, 6 (1) (2018) 46-54.
- [15] E. Rabinowicz, Abrasive wear resistance as a materials test, *Lubr. Eng.*, 33 (1977) 378-381.
- [16] E. Rabinowicz, L. Dunn, P. Russell, A study of abrasive wear under three-body conditions, *Wear*, 4 (1961) 345-355.
- [17] A. Ersoy, M. Waller, Wear characteristics of PDC pin and hybrid core bits in rock drilling, *Wear*, 188 (1995) 150-165.
- [18] L. Sinor, T. Warren, Drag bit wear model, *SPE Annual Technical Conference and Exhibition*, Society of Petroleum Engineers, 1987.
- [19] R.J. Waughman, J.V. Kenner, R.A. Moore, Real-time specific energy monitoring reveals drilling inefficiency and enhances the understanding of when to pull worn PDC bits, *IADC/SPE Drilling Conference*, Society of Petroleum Engineers, 2002.

- [20] T.K. Al-Ameri, M.S. Jafar, J. Pitman, Hydrocarbon Generation Modeling of the Basrah Oil Fields, Southern Iraq, Jadiriyah, Iraq: University of Baghdad, 2011.
- [21] R. Trezona, D. Allsopp, I. Hutchings, Transitions between two-body and three-body abrasive wear: influence of test conditions in the microscale abrasive wear test, *Wear*, 225 (1999) 205-214.
- [22] M.Priest, Introduction to tribology, in: University.of Leeds (Ed.), 2012.
- [23] A.P. Mouritz, I. Hutchings, The abrasive wear of rock drill bit materials, Society of Petroleum Engineers, 1991.
- [24] B.V. Gokhale, Rotary drilling and blasting in large surface mines, CRC Press, 2010.
- [25] J. Eason, J. Westhoff, J. Stevens, Sintered bodies for earth-boring rotary drill bits and methods of forming the same, Google Patents, 2007.
- [26] Nguyen, T. *Drilling Engineering –An Introduction to Drilling Drill Bits PE 311*, 2011 [Online]. [Accessed 1 November 2015]. Available from:  
[http://www.google.co.uk/url?sa=t&rct=j&q=&esrc=s&frm=1&source=web&cd=1&ved=0CCEQFjAAahUKEwiC\\_pqwrOXIAhVEQBoKHZ8UBeE&url=http%3A%2F%2Finfohost.nmt.edu%2F~petro%2Ffaculty%2FNguyen%2FPE311%2FPresentations%2FC3%2F1\\_Classification.ppt&usg=AFQjCNGxVyeO5AwBm5bH4x74FXyg0QUe5A&sig2=3D8Ow4sBO3AX8SwhE22Eeg](http://www.google.co.uk/url?sa=t&rct=j&q=&esrc=s&frm=1&source=web&cd=1&ved=0CCEQFjAAahUKEwiC_pqwrOXIAhVEQBoKHZ8UBeE&url=http%3A%2F%2Finfohost.nmt.edu%2F~petro%2Ffaculty%2FNguyen%2FPE311%2FPresentations%2FC3%2F1_Classification.ppt&usg=AFQjCNGxVyeO5AwBm5bH4x74FXyg0QUe5A&sig2=3D8Ow4sBO3AX8SwhE22Eeg)
- [27] Q.V. Nguyen, Insert attack angle for roller cone rock bits, Google Patents, 1991.
- [28] Nicholas, J. L, John, H. S. and Redd, H. S., *Drilling bit having a cutting element co-sintered with a cone structure*, 2011. EP 2122112 B1.
- [29] R.K. Abbas, Analysis of the Wear of Oil Wells Drill Bits, University of Leeds, 2015 (Doctoral dissertation).
- [30] D. McGehee, J. Dahlem, J. Gieck, B. Kost, D. Lafuze, C. Reinsvold, S. Steinke, The IADC Roller Bit Classification System, SPE/IADC Drilling Conference, Society of Petroleum Engineers, 1992.
- [31] Nelson, S. A., *Tulane University website, 2015*. [Online]. [Accessed 12 February 2016]. Available from:  
<http://www.tulane.edu/~sanelson/eens1110/geotime.htm>