



UNIVERSITY OF LEEDS

This is a repository copy of *In-situ Measurement of Transducer Impedance using AFE Active Termination through Analysis of Ultrasound Echoes*.

White Rose Research Online URL for this paper:
<http://eprints.whiterose.ac.uk/156528/>

Version: Accepted Version

Proceedings Paper:

Cowell, D orcid.org/0000-0003-0854-542X, Carpenter, T orcid.org/0000-0001-5676-1739, Fisher, B et al. (1 more author) (2017) In-situ Measurement of Transducer Impedance using AFE Active Termination through Analysis of Ultrasound Echoes. In: Proceedings of the 2017 IEEE International Ultrasonics Symposium (IUS). 2017 IEEE International Ultrasonics Symposium (IUS), 06-09 Sep 2017, Washington, DC, USA. IEEE . ISBN 978-1-5386-3384-7

<https://doi.org/10.1109/ULTSYM.2017.8092162>

© 2017, IEEE. Personal use of this material is permitted. Permission from IEEE must be obtained for all other uses, in any current or future media, including reprinting/republishing this material for advertising or promotional purposes, creating new collective works, for resale or redistribution to servers or lists, or reuse of any copyrighted component of this work in other works.

Reuse

Items deposited in White Rose Research Online are protected by copyright, with all rights reserved unless indicated otherwise. They may be downloaded and/or printed for private study, or other acts as permitted by national copyright laws. The publisher or other rights holders may allow further reproduction and re-use of the full text version. This is indicated by the licence information on the White Rose Research Online record for the item.

Takedown

If you consider content in White Rose Research Online to be in breach of UK law, please notify us by emailing eprints@whiterose.ac.uk including the URL of the record and the reason for the withdrawal request.



eprints@whiterose.ac.uk
<https://eprints.whiterose.ac.uk/>

In-situ Measurement of Transducer Impedance using AFE Active Termination through Analysis of Ultrasound Echoes

David Cowell[†], Thomas Carpenter[‡], Benjamin Fisher and Steven Freear
 Ultrasonics and Instrumentation Group, School of Electronic and Electrical Engineering,
 University of Leeds, Leeds, LS2 9JT, UK
 Email: [†]d.m.j.cowell@leeds.ac.uk, [‡]t.carpenter@leeds.ac.uk

Abstract—Measurement of transducer impedance in ultrasound systems indicates both the performance of a transducer and the presence of damaged elements and cables. Load impedance analysis is typically performed with dedicated test equipment and is a time consuming and thus expensive process, especially for high channel count systems. This paper proposes a method for the measurement of channel source impedance (transducer, coaxial cable and T/R switch) through the use of an integrated receiver analogue front end with configurable termination resistance. The proposed method is first demonstrated using a pitch-catch configuration using a separate source transducer to excite the transducer under test. Subsequently the method is demonstrated the Ultrasound Array Research Platform (UARP) and a linear array transducer in a pulse echo mode where the transducer impedance is determined through the analysis of two ultrasound echoes. The proposed method is especially suited to rapid transducer testing in the field, such as in a hospital, or where access to the transducer is not possible as in many industrial processes.

I. INTRODUCTION

Periodic calibration of ultrasound imaging and instrumentation systems is critical to identify transducer condition or system failure. Performing impedance measurement allows the monitoring of transducer degradation and identification of cable failure. Impedance analysis is typically performed using a dedicated calibrated impedance analyser, however this process is extremely time consuming and costly for array transducers with many elements and is thus not practical for infield use.

A typical impedance analyser, as shown in Fig.1, methodically applies a number of excitation voltage signals each a sinusoidal tone bursts of increasing frequency, V_S through a series impedance, Z_s , causing a voltage, V_L , to be measured across the load or transducer (XDR) impedance, Z_{XDR} .

$$Z_{XDR} = \frac{V_L Z_s}{V_S - V_L} \quad (1)$$

In this impedance measurement scenario, the transducer emits an ultrasound wave when the measurement frequency is within the transducers bandwidth. Care must be taken such that these emitted waves are not received by the transducer causing errors in the measured impedance.

The use of a dedicated impedance analyser and the use of voltage and current probes is described in ASTM standards

[1] and academic studies [2]. Lopez-Sanchez and Schmerr proposed a method using a pulse-echo setup and voltage and current measurements to calculate transducer impedance in transmit mode and transducer sensitivity by combining transmit and receive mode current and voltage measurements [3]. Inferring current by measuring the source voltage and voltage drop across a reference resistance and transducer has been demonstrated [4] [5] [6], however this measurement circuit topology is not typical in ultrasound systems front ends.

This paper proposes a method of concurrent in-situ impedance measurement of all array elements without additional circuitry, instrumentation modification or the use of dedicated measurement equipment. In-situ impedance is measured through analysis of two received ultrasound waveforms in an imaging system with configurable receive mode termination impedance.

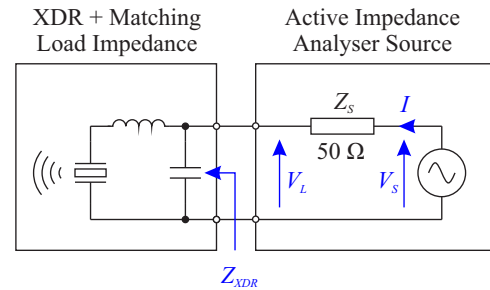

Fig. 1. Measuring Load Impedance Using Series Resistor

II. PROPOSED IMPEDANCE MEASUREMENT TECHNIQUE

In the proposed method of measuring impedance, rather than driving the transducer through a reference series resistor, the transducer is instead excited using an ultrasound wave with sufficient bandwidth to provide energy over the frequency range of interest. Additionally the transducer is connected to a known load impedance, resulting in the circuit shown in Fig.2a. By considering the transducer as a voltage source with a series impedance, a simplified equivalent circuit, Fig.2b can be derived. By comparing this to the original impedance analyser circuit (Fig.1) it can be seen to be equivalent with only the reference impedance and unknown impedance swapped.

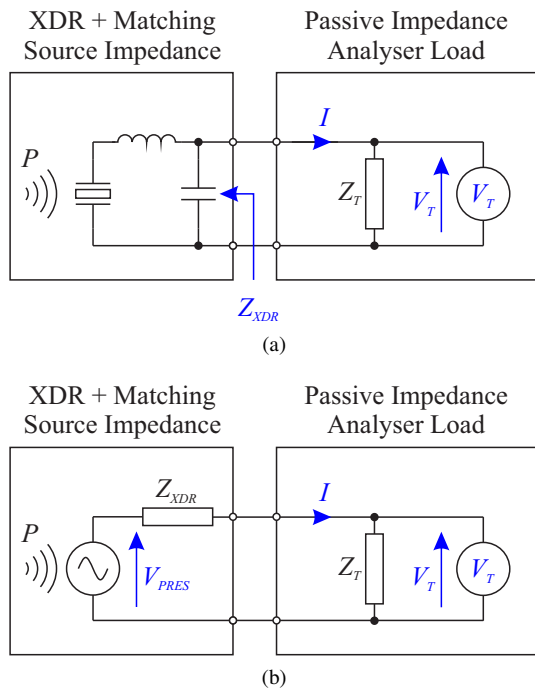

Fig. 2. Measuring Transducer Impedance Using Load Resistor as Physical Circuit (a) and Equivalent Circuit (b)

Unlike the method in Fig.1, this proposed method no longer requires any dedicated circuitry. The series reference resistor has been replaced with a load resistor which is already found in most analogue front ends (AFE) in the form of a termination resistor, and the voltage measurement device replaced by the Analogue to Digital Converter (ADC).

As with any impedance measurement it is necessary to measure over a range of frequencies of interest. As such the ultrasound signal used to excite the transducer must therefore have either sufficient bandwidth to test the whole range of interest (e.g. a chirp signal) or several tests performed using narrower bandwidth signals. The signal can be produced either from a different transducer fired directly at the transducer being measured, or can be an echo signal from a static reflector. Wide bandwidth ultrasound signals can easily be produced using transmitter designs utilising 5-Level pulsers and using methods such as harmonic reduction PWM [7] [8] [9].

By considering the proposed circuit shown in Fig.2b as a simple potential divider, the voltage, V_{PRES} , generated by the incoming pressure signal, P , can be represented in terms of the transducer source impedance, the load/termination impedance, and the voltage measured across the load as shown in equation 2 below.

$$V_{PRES} = V_T \left(1 + \frac{Z_{XDR}}{Z_T} \right) \quad (2)$$

The main hurdle in deriving the transducer source impedance Z_{XDR} using this method is not knowing the

voltage generated by the ultrasound pressure wave. In the original impedance measurement approach, this signal was a known reference voltage, however here it is an unknown reflection. This problem can in fact be solved by performing two measurements with two distinct termination resistances assuming the received echo is the same in both measurements. If for example during both measurements transducer was to be driven by the same transmit signal and fired at a static reflector, the resulting echo response should be the same.

Assuming then that the measured pressure wave is the same, equation 3 can be derived by equating V_{PRES} of the two measurements. This can then be rearranged as equation 4 and finally solved for Z_{XDR} as in equation 5.

$$V_{T(1)} \left(1 + \frac{Z_{XDR}}{Z_{T(1)}} \right) = V_{T(2)} \left(1 + \frac{Z_{XDR}}{Z_{T(2)}} \right) \quad (3)$$

$$V_{T(2)} - V_{T(1)} = Z_{XDR} \left(\frac{V_{T(1)}}{Z_{T(1)}} - \frac{V_{T(2)}}{Z_{T(2)}} \right) \quad (4)$$

$$Z_{XDR} = \frac{Z_{T(1)}Z_{T(2)}(V_{T(2)} - V_{T(1)})}{Z_{T(2)}V_{T(1)} - Z_{T(1)}V_{T(2)}} \quad (5)$$

From equation 5 it can be seen that the transducer impedance is now entirely derived in terms of quantities which can be measured by the AFE. In the equations $Z_{T(1)}$ and $V_{T(1)}$ represent the impedance of the termination and ADC voltage during the first measurement respectively, while $Z_{T(2)}$ and $V_{T(2)}$ represent the same but for the second measurement.

III. EXPERIMENTAL VALIDATION

A. Test Bench Proof of Concept

In order to determine the validity of the method for measuring impedance, a test bench proof of concept experiment was devised using two Olympus NDT V323 2.25 MHz ultrasound transducers (XDR), a Keysight 33600A Arbitrary Waveform Generator (AWG), a changeable load resistor and a Keysight MSOS104A oscilloscope. The experimental setup for this proof of concept is shown in Fig.3. Using this simplified test bench setup, the method can be validated by determining whether or not an accurate impedance measurement can be made.

For the experiment, the source XDR was driven by the AWG to produce a wide bandwidth ultrasound chirp signal. The ultrasound signal was then coupled through to the test XDR by placing both transducers in a water vessel pointing directly towards each other. A load resistor was then placed on the output of the DUT and the resulting voltage waveform captured using the oscilloscope.

A calibrated Omicrom Bode 100 Vector Network Analyser (VNA) was used to take a reference measurement of the impedance of the submerged test XDR while the source XDR was not being driven. The data from this reference measurement is shown in blue in Fig.4. Two measurements

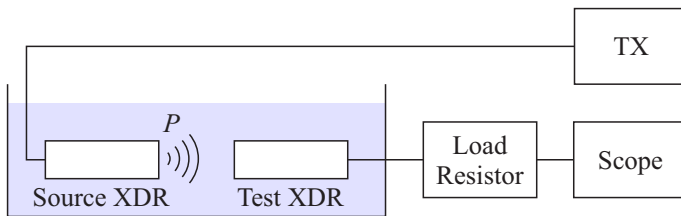

Fig. 3. Experimental Setup for Impedance Measurement of 2.25 MHz Single Transducer Using External Termination Resistor

were then taken with the oscilloscope using 100Ω and 50Ω termination resistors respectively. The impedance was then calculated using equation 5 and is presented in black in Fig.4.

The two impedance measurements clearly show a strong correlation over the frequency bandwidth of the transducer. At the lower end of the frequency range measured the two measurements start to diverge due to lack of transmit power within that region. As discussed in section II, for this method to be successful the ultrasound signal must provide energy at frequencies of interest explaining why the impedance only matches over the bandwidth range of the transducer. The test bench experiment clearly validates the equations derived for the proposed impedance measurement method and so warranted further experimentation.

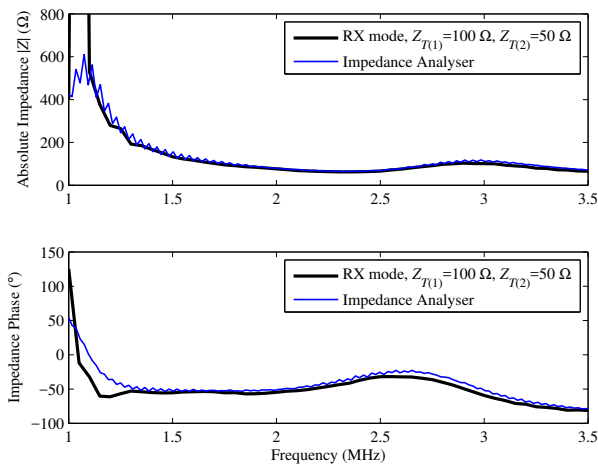

Fig. 4. Impedance of 2.25 MHz Transducer Measured Using VNA vs. Proposed Method with External Termination

B. Integrated Front End Validation

Typical ultrasound systems have integrated transmit receive switches to drive the transducer and receive echo signals. This circuitry adds additional complexity into the measurement path as shown in Fig.5. To determine whether the method works despite the added complexity, a second experimental setup was made, Fig.6, to measure the impedance of an LT11-4 medical linear array transducer connected to the Ultrasound Array Research Platform (UARP) developed by the University of Leeds [10].

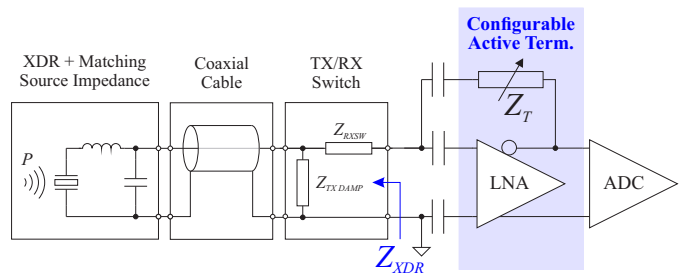

Fig. 5. Structure of a Typical Analogue Front End for an Ultrasound Imaging System Showing Increased Complexity of Signal Path

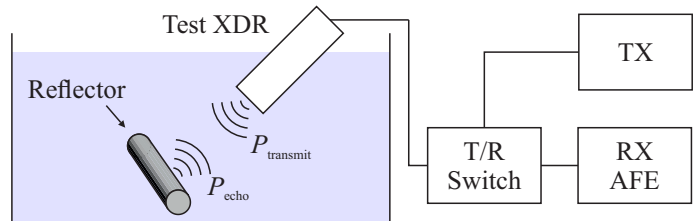

Fig. 6. Experimental Setup for Impedance Measurement of an LT11-4 Transducer Connected to the UARP System Using the Proposed Method

The AFE of the UARP system utilises Texas Instruments AFE5807 integrated circuitry (IC) for A-D conversion. These ICs contain active integrated input termination to the first stage of low noise amplifier (LNA) which have impedances that are software controlled. The input termination can be rapidly reconfigured in approximately $2 \mu\text{s}$. To match preliminary experiment, values of nominally 100Ω and 50Ω were selected as the two termination impedances, $Z_{T(1)}$ and $Z_{T(2)}$ respectively. The impedance of these terminations was measured using a vector network analyser to account for any frequency dependent variation in the calculations. The impedance of the terminations was measured over several channels and multiple ICs and found to be fairly consistent indicating that the measured impedance can reasonably be used across all channels of the UARP system without the need for calibration of each individual channel.

The UARP system was used to excite the transducer elements to produce a wide bandwidth ultrasound signal. A chirp $10 \mu\text{s}$ duration, 7.5 MHz central frequency and 7 MHz bandwidth with Hann windowing was generated using switched 5 level HRPWM [7] [8]. The resulting switched waveforms used to drive all elements of the LT11-4 transducer in parallel using MAX14808 ultrasound pulsers with integrated T/R switches.

The system was programmed to transmit and receive an echo from a cylindrical metallic reflector located approximately 50 mm from the front face of the transducer. The system was sequenced to first image with 100Ω receive termination, then 50Ω receive termination as shown in Fig.7. Examination of the two received waveforms clearly shows the effect of the termination impedance on the received signal magnitudes.

The resulting RF data was processed in Matlab to calculate the channel impedance as shown in Fig.8. For reference the

IV. CONCLUSIONS

A new methodology for the rapid measurement of the combined impedance of a ultrasound imaging systems transducer, cabling, T/R switches (or multiplexor) and passive filtering components has been presented.

The proposed methodology is especially suited to the measurement of receive mode impedance on array imaging systems where hundreds of channels may be present.

It was demonstrated that the proposed method is applicable using both single element immersion transducers with discrete test equipment and using linear array imaging transducers and the University of Leeds UARP imaging system without requiring any circuit additions or modifications. Measured impedances were compared with those obtained with calibrated commercial impedance analysers showing good agreement.

The proposed method is suitable for adoption in field tests of medical ultrasound equipment during periodic system checks and industrial measurement systems where transducers may be in the field for extended periods of time such as flow metering and process monitoring.

REFERENCES

- [1] "Standard Guide for Evaluating Characteristics of Ultrasonic Search Units," ASTM International, West Conshohocken, PA, Standard, Mar 1999.
- [2] Q. Pan, D. Xiao, M. Deng, H. Ren, Y. Xu, and C. Xu, "A voltage-current method of measuring ultrasonic transducer impedance," in *2013 Far East Forum on Nondestructive Evaluation/Testing: New Technology and Application*, June 2013, pp. 125–128.
- [3] A. L. Lopez-Sanchez and L. W. Schmerr, "Determination of an ultrasonic transducer's sensitivity and impedance in a pulse-echo setup," *IEEE Transactions on Ultrasonics, Ferroelectrics, and Frequency Control*, vol. 53, no. 11, pp. 2101–2112, November 2006.
- [4] Z. Xinyi and L. Sang, "Large-signal impedance measurements of piezoelectric ultrasonic transducers," in *2015 12th IEEE International Conference on Electronic Measurement Instruments (ICEMI)*, vol. 02, July 2015, pp. 731–736.
- [5] *Bode 100 User Manual*, OMICRON Electronics GmbH, 2010.
- [6] *Impedance Measurement Handbook*, Keysight Technologies, Nov. 2016.
- [7] D. M. J. Cowell, P. R. Smith, and S. Freear, "Phase-Inversion-based Selective Harmonic Elimination (PI-SHE) in multi-level switched-mode tone- and frequency- modulated excitation," *IEEE Transactions on Ultrasonics, Ferroelectrics, and Frequency Control*, vol. 60, no. 6, pp. 1084–1097, June 2013.
- [8] P. R. Smith, D. M. J. Cowell, and S. Freear, "Width-modulated square-wave pulses for ultrasound applications," *IEEE Transactions on Ultrasonics, Ferroelectrics, and Frequency Control*, vol. 60, no. 11, pp. 2244–2256, November 2013.
- [9] P. R. Smith, D. M. J. Cowell, B. Raiton, C. V. Ky, and S. Freear, "Ultrasound array transmitter architecture with high timing resolution using embedded phase-locked loops," *IEEE Transactions on Ultrasonics, Ferroelectrics, and Frequency Control*, vol. 59, no. 1, pp. 40–49, January 2012.
- [10] S. Harput, M. Arif, J. McLaughlan, D. M. J. Cowell, and S. Freear, "The effect of amplitude modulation on subharmonic imaging with chirp excitation," *IEEE Transactions on Ultrasonics, Ferroelectrics, and Frequency Control*, vol. 60, no. 12, pp. 2532–2544, Dec 2013.

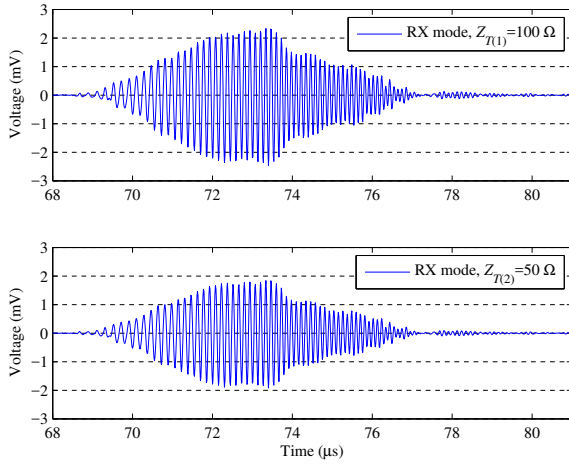

Fig. 7. Echo Signals Recorded by UARP for 50 Ω and 100 Ω Termination Impedances

channel impedance was measured at the RX AFE input using the Bode 100 VNA of which the impedance is shown in Fig.8 for comparison.

Comparing the frequency dependant impedance measured using the proposed method with that measured using a VNA shows an overall good correlation. However, a drift in absolute impedance can be observed at the transducers low frequency bounds, and a drift in phase at the transducers high frequency bounds. It is believed that this error may be associated with the DC blocking capacitors present at the AFEs input. These capacitors were not present when measuring the active termination impedances of the AFE. It is believed that the accuracy of the impedance system may be further improved with development of a system calibration methodology.

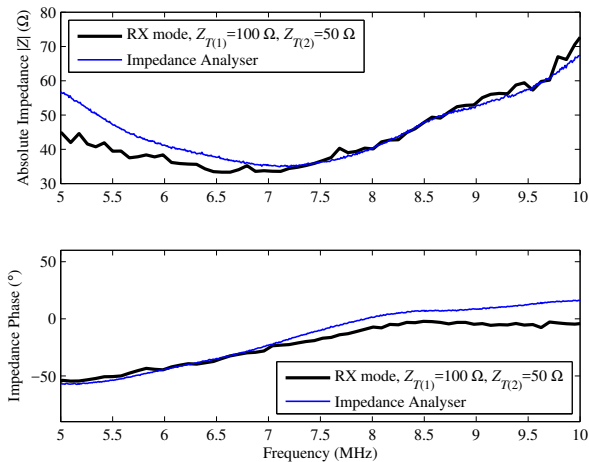

Fig. 8. Impedance of LT11-4 Transducer Coupled With UARP AFE Measured Using VNA vs. Proposed Method with Reconfiguration Termination