



Deposited via The University of Sheffield.

White Rose Research Online URL for this paper:

<https://eprints.whiterose.ac.uk/id/eprint/155180/>

Version: Accepted Version

---

**Article:**

Humphries, M.D. and Prescott, T.J. (2010) The ventral basal ganglia, a selection mechanism at the crossroads of space, strategy, and reward. *Progress in Neurobiology*, 90 (4). pp. 385-417. ISSN: 0301-0082

<https://doi.org/10.1016/j.pneurobio.2009.11.003>

---

Article available under the terms of the CC-BY-NC-ND licence  
(<https://creativecommons.org/licenses/by-nc-nd/4.0/>).

**Reuse**

This article is distributed under the terms of the Creative Commons Attribution-NonCommercial-NoDerivs (CC BY-NC-ND) licence. This licence only allows you to download this work and share it with others as long as you credit the authors, but you can't change the article in any way or use it commercially. More information and the full terms of the licence here: <https://creativecommons.org/licenses/>

**Takedown**

If you consider content in White Rose Research Online to be in breach of UK law, please notify us by emailing [eprints@whiterose.ac.uk](mailto:eprints@whiterose.ac.uk) including the URL of the record and the reason for the withdrawal request.

# The ventral basal ganglia, a selection mechanism at the crossroads of space, strategy, and reward.

Mark D. Humphries<sup>\*a,b</sup>, Tony Prescott<sup>a</sup>

<sup>a</sup>*Adaptive Behaviour Research Group, Department of Psychology, University of Sheffield, S10 2TN, UK*

<sup>b</sup>*Group for Neural Theory, Ecole Normale Supérieure Département d'Études Cognitives, 29, rue d'Ulm 75005 Paris. France*

---

## Abstract

The basal ganglia are often conceptualised as three parallel domains that include all the constituent nuclei. The ‘ventral domain’ appears to be critical for learning flexible behaviours for exploration and foraging, as it is the recipient of converging inputs from amygdala, hippocampal formation and prefrontal cortex, putatively centres for stimulus evaluation, spatial navigation, and planning/contingency, respectively. However, compared to work on the dorsal domains, the rich potential for quantitative theories and models of the ventral domain remains largely untapped, and the purpose of this review is to provide the stimulus for this work. We systematically review the ventral domain’s structures and internal organisation, and propose a functional architecture as the basis for computational models. Using a full schematic of the structure of inputs to the ventral striatum (nucleus accumbens core and shell), we argue for the existence of many identifiable processing channels on the basis of unique combinations of afferent inputs. We then identify the potential information represented in these channels by reconciling a broad range of studies from the hippocampal, amygdala and prefrontal cortex literatures with known properties of the ventral striatum from lesion, pharmacological, and electrophysiological studies. Dopamine’s key role in learning is reviewed within the three current major computational frameworks; we also show that the shell-based basal ganglia sub-circuits are well placed to generate the phasic burst and dip responses of dopaminergic neurons. We detail dopamine’s modulation of ventral basal ganglia’s inputs by its actions on pre-synaptic terminals and post-synaptic membranes in the striatum, arguing that the complexity of these effects hint at computational roles for dopamine beyond current ideas. The ventral basal ganglia are revealed as a constellation of multiple functional systems for the learning and selection of flexible behaviours and of behavioural strategies, sharing the common operations of selection-by-disinhibition and of dopaminergic modulation.

*Key words:* nucleus accumbens, shell, core, action selection, reward prediction error, incentive salience, spatial navigation

---

*Abbreviations.* cAB: caudal accessory basal nucleus (of the amygdala); rAB: rostral accessory basal nucleus (of the amygdala); ac: anterior commissure; ACd: dorsal anterior cingulate cortex; AI<sub>d</sub>: dorsal agranular insular cortex; AI<sub>v</sub>: ventral agranular insular cortex; cBmg: caudal magnocellular basal complex (of the amygdala); rBmg: rostral magnocellular basal complex (of the amygdala); Bpc: parvicellular basal complex (of the amygdala); DG: dentate gyrus; DLS: dorsolateral striatum; DMS: dorsomedial striatum; EC: entorhinal cortex; Fr2: cortical “frontal region 2”; FS: fast-spiking (interneuron); GP: globus pallidus; GP<sub>e</sub>: external division of the globus pallidus (primate); GP<sub>i</sub>: internal division of the globus pallidus (primate); IL: infralimbic cortex; LEC: lateral entorhinal cortex; LH: lateral hypothalamus; LPO: lateral pre-optic area; LTS: low-threshold spiking (interneuron); LV: lateral ventricle; MEC: medial entorhinal cortex; MD: mediodorsal nucleus of the thalamus; MO: medial orbital cortex; MSN: medium spiny neuron; NAcc: nucleus accumbens; PL: prelimbic cortex; PPN: pedunculopontine nucleus; SNc: substantia nigra pars com-

pacta; mSNc: medial division of the substantia nigra pars compacta; SNr: substantia nigra pars reticulata; STN: subthalamic nucleus; dSub: dorsal subiculum; iSub: intermediate subiculum; vSub: ventral subiculum; VP: ventral pallidum; VP<sub>d</sub>: dorso-lateral division of the ventral pallidum; VP<sub>vl</sub>: ventro-lateral division of the ventral pallidum; VP<sub>m</sub>: medial division of the ventral pallidum; VTA: ventral tegmental area; VTA<sub>l</sub>: lateral division of the ventral tegmental area; VTA<sub>m</sub>: medial division of the ventral tegmental area.

## Contents

<b>1</b>	<b>Introduction</b>	<b>2</b>
<b>2</b>	<b>A basal ganglia primer</b>	<b>3</b>
2.1	The troubles with dopamine . . . . .	3
2.2	Delineating the ‘ventral’ basal ganglia . . . . .	3
<b>3</b>	<b>A new functional anatomy of the ventral basal ganglia</b>	<b>5</b>
3.1	The core-based basal ganglia circuit . . . . .	5
3.1.1	Patch and matrix in the NAcc core . . . . .	7
3.2	The shell-based basal ganglia circuits . . . . .	8

---

\*Corresponding author

Email address: m.d.humphries@sheffield.ac.uk (Mark D. Humphries)

3.3	Common properties of the ventral basal ganglia domain . . . . .	9	<b>8</b>	<b>A roadmap for quantitative models of ventral basal ganglia</b>	<b>26</b>
3.3.1	The ventral striatal microcircuit . . . . .	9	8.1	A theory and model of the NAcc core sub-circuit	26
3.3.2	Position of the pedunculopontine nucleus within the ventral basal ganglia . . . . .	9	8.1.1	Multiple selection circuits originating in the core . . . . .	27
<b>4</b>	<b>Dopamine and the striatum</b>	<b>9</b>	8.2	Theoretical roles of the NAcc shell . . . . .	29
4.1	Types of dopaminergic receptor in the striatum	10	8.2.1	Shell sub-circuits control dynamics of dopamine cells . . . . .	29
4.2	The distribution of dopaminergic receptors in the striatum . . . . .	10	8.2.2	Simple selection by shell sub-circuits . . . . .	29
4.3	The effects of of dopaminergic receptor activation in the striatum . . . . .	11	8.2.3	Multiple roles of each sub-circuit? . . . . .	30
4.3.1	Dopamine and synaptic plasticity . . . . .	12	8.2.4	Further model development . . . . .	31
<b>5</b>	<b>Information carried by the primary inputs to the ventral basal ganglia</b>	<b>12</b>	8.3	Integration with the dorsal basal ganglia domains	31
5.1	The hippocampal formation inputs . . . . .	13	<b>9</b>	<b>Conclusions</b>	<b>31</b>
5.1.1	Detail of the hippocampal formation input to ventral striatum . . . . .	13	<b>A</b>	<b>Novel conclusions and predictions</b>	<b>32</b>
5.1.2	Place fields . . . . .	13	<b>B</b>	<b>Open questions</b>	<b>32</b>
5.1.3	Path integration, routes, and grid cells . . . . .	13	<b>C</b>	<b>Population-level model of shell sub-circuit</b>	<b>33</b>
5.1.4	Spatial navigation or memory? . . . . .	15	<b>1. Introduction</b>		
5.2	Prefrontal cortex inputs . . . . .	16		The basal ganglia, a group of inter-connected nuclei in the vertebrate fore- and mid-brain, form the centre of a vast literature. This literature can be roughly divided by its focus on either the dorsal or ventral parts of the basal ganglia, and corresponding research themes of workers in those two fields. Computational models, whether explicitly stated or not, focus almost exclusively on the dorsal basal ganglia (e.g. Contreras-Vidal and Stelmach, 1995; Beiser and Houk, 1998; Berns and Sejnowski, 1998; Gurney et al., 2001b; Humphries et al., 2006; Leblois et al., 2006), in large part because of the large number of available systematic reviews of the dorsal basal ganglia (e.g. Parent and Hazrati, 1995; Gerfen and Wilson, 1996; Mink, 1996; Redgrave et al., 1999a; Bolam et al., 2000; Gurney et al., 2001a). We present this review and synthesis to provide the same level of systematically organised information, sufficient for building computational models that are specific to ventral basal ganglia, and to stimulate further development of quantitative, theoretical thinking in this field. Our aim is to also to help bridge the surprisingly disparate literatures on the dorsal and ventral basal ganglia. We build here on previous excellent reviews of the ventral basal ganglia, particularly (Pennartz et al., 1994; Groenewegen et al., 1999b,c; Ikemoto, 2007; Nicola, 2007). Our functional focus in particular is on the key role they appear to play in exploration and foraging (Swanson, 2000; Zahm, 2006) through the co-ordination of spatial navigation, reward evaluation, and behavioural strategy.	
5.2.1	Detail of the prefrontal cortex inputs to ventral basal ganglia . . . . .	16		A note on neuroscience terminology is appropriate at this point to orient the computationally-inclined reader. The names and boundaries given to brain structures are often the focus of fierce debate. Divisions made on anatomical grounds of, for example, neuron shape and size may not correlate with divisions that could be made based on neurotransmitter content, or projection targets, or sources of afferent inputs. Ideally, a definable brain structure has unique combinations of all these properties;	
5.2.2	Correlates of strategies and goals in medial prefrontal cortex . . . . .	16			
5.2.3	Correlates of incentive value in orbitofrontal cortex . . . . .	17			
5.3	Amygdala inputs . . . . .	17			
5.3.1	Encoding of stimulus value . . . . .	18			
5.4	Thalamic inputs . . . . .	18			
5.5	Dopaminergic inputs . . . . .	18			
5.5.1	Computational theories of phasic dopamine . . . . .	20			
5.5.2	Different theories for different roles in separate regions of striatum? . . . . .	20			
5.5.3	Compatible computational theories of phasic dopamine? . . . . .	21			
5.5.4	Computational roles of tonic dopamine	21			
5.5.5	Dopamine and spatial navigation . . . . .	22			
<b>6</b>	<b>Behavioural roles of the ventral striatum</b>	<b>22</b>			
6.1	Behavioural consequences of ventral striatal manipulations . . . . .	22			
6.2	Behavioural correlates of ventral striatal activity	23			
<b>7</b>	<b>Convergence of inputs: channels within the basal ganglia</b>	<b>24</b>			
7.1	Macroscopic channels . . . . .	24			
7.2	Microscopic channels . . . . .	25			
7.3	Enumerating channels within the ventral basal ganglia . . . . .	25			
7.4	Evidence for convergence of inputs at single cells in ventral striatum . . . . .	26			

yet these are all structural properties, and may ultimately not correlate with the functional properties of those neurons, such as their response to the sound or colour of a stimulus. Thus, here, as is often the case in discussions of the brain, it is not possible to cleanly separate the structural and functional aspects, as each informs and constrains the other. In what follows, we use data and brain terminology mostly derived from rat studies. This approach is adopted to ensure consistency and compatibility when interpreting results from different studies, because the rat brain is the best studied of all vertebrates. Corroborating evidence from other species is discussed where available.

## 2. A basal ganglia primer

We begin by outlining the classic model of anatomy that is often simply labelled ‘basal ganglia’, despite, as will become clear, only strictly applying to the dorsal basal ganglia. This will provide a useful point of comparison for the elaboration of the ventral basal ganglia. Such treatments of classic basal ganglia anatomy identify six main structures (Bolam et al., 2000), illustrated in Figure 1a. The striatum forms the largest part of the basal ganglia, and is the primary input nucleus. The small subthalamic nucleus (STN) forms the other input structure of the basal ganglia, receiving input from cortical and thalamic sources. The globus pallidus (GP) – termed external globus pallidus (GPe) in primate anatomy – receives input from these structures and projects predominantly within the basal ganglia. The substantia nigra pars reticulata (SNr) and entopeduncular nucleus – internal division of the globus pallidus (GPi) in primate anatomy – form the output nuclei, receiving input from striatum, STN, and GP, and projecting to thalamic and brainstem regions. Finally, the dopamine neurons of the substantia nigra pars compacta (SNc) project mainly to the striatum.

The striatum comprises predominantly so-called medium spiny neurons (MSNs), which form around 90-97% of the neuron population in the rat (Tepper and Bolam, 2004; Matamales et al., 2009), and are the output neurons of the striatum. The projecting axon gives off local collaterals that contact dendritic trees of neighbouring MSNs (Wilson and Groves, 1980). The remaining 3-10% comprises at least three main interneuron classes, the giant aspiny cholinergic neurons, the medium aspiny GABAergic neurons, and the neurons co-expressing nitric oxide, somatostatin, and neuropeptide Y (Tepper and Bolam, 2004). The dominant sub-class of aspiny GABAergic interneurons co-expresses parvalbumin, and these appear to correlate with the physiological class of fast-spiking (FS) interneurons (Kawaguchi et al., 1995). The interneuron co-expressing nitric oxide, somatostatin, and neuropeptide Y appears to correlate with the low-threshold spiking (LTS) physiological class (Kawaguchi et al., 1995), and these may also release GABA (Kubota and Kawaguchi, 2000). The cholinergic interneurons appear to correlate with the *in vitro* class of long-lasting after-hyperpolarisation interneurons (Kawaguchi et al., 1995) and the *in vivo* class of tonically-active neurons (Cragg, 2006).

The MSNs are themselves sub-divided by their main targets. MSNs in ‘patch’ regions, often identified by dense staining for  $\mu$ -opiate receptors (Gerfen, 1984), project only to dopaminergic

cells of the brainstem. The majority of the MSNs form the remaining ‘matrix’ surrounding the patches, and divide into two further populations: approximately half project to the GP and half project to the SNr (Gerfen and Young, 1988; Matamales et al., 2009) – a subset of the latter also send a collateral to GP (Kawaguchi et al., 1990). This anatomical target split is correlated with co-expression of substance P and dynorphin for SNr-targeting MSNs, and enkephalin for GP-targeting MSNs (Gerfen and Young, 1988; Bolam et al., 2000). More controversially, this target split also seems to correspond to MSNs respectively expressing D1 and D2 receptors for dopamine (Gerfen et al., 1990).

### 2.1. The troubles with dopamine

Research on dopamine within the striatum is seemingly in a state of permanent controversy over all major topics, the types of dopamine receptors, their distribution, and the effects of their activation. Dopamine receptors in the central nervous system are classified as either D1-like (D1 and D5 receptors) or D2-like (D2, D3, and D4 receptors) (Missale et al., 1998). The receptors of each family bind the same ligands, though the D2-like family show clear-cut differences in affinity for some agonists and antagonists (Missale et al., 1998). Hence, the vast number of studies that use dopamine receptor agonists or antagonists to tease apart the effects of dopamine require careful interpretation, as at best they distinguish only between the involvement of D1- and D2-like receptors. Resolving many controversies in the dopamine literature is the focus of much research using the newly developed bacterial artificial chromosome (BAC) transgenic mice (Heintz, 2001). These mice express a fluorescent protein controlled by a promoter for a specific intra-cellular gene. Hence, the presence of each of the five dopamine receptor types can be separately assessed, or simultaneously examined using separate fluorescent proteins (Heintz, 2001; Matamales et al., 2009).

From these mice lines, we now know that every MSN expresses either or both of D1 and D2 receptors, with the vast majority – 95% in dorsal striatum – expressing only one type in detectable quantities (Bertran-Gonzalez et al., 2008; Matamales et al., 2009). Moreover, BAC mice studies have revealed clear morphological and dendritic excitability differences between MSNs expressing D1 and D2 receptors (Gertler et al., 2008; Day et al., 2008). Hence, throughout we will talk of D1-*dominant* and D2-*dominant* MSNs. Section 4 details the nuances in this story, and the full picture of dopamine across the striatum.

### 2.2. Delineating the ‘ventral’ basal ganglia

Three broad domains of dorsolateral (DLS), dorsomedial (DMS), and ventral striatum have been distinguished by many authors (Joel and Weiner, 2000a; Yin and Knowlton, 2006). Figure 1b illustrates their approximate organisation: the borders of the dorsomedial with the dorsolateral and the ventral striatum are not clear-cut, but depend on the criteria used to define the three regions. The dorsolateral striatum is delineated by the main extent of primary motor and somatosensory cortical

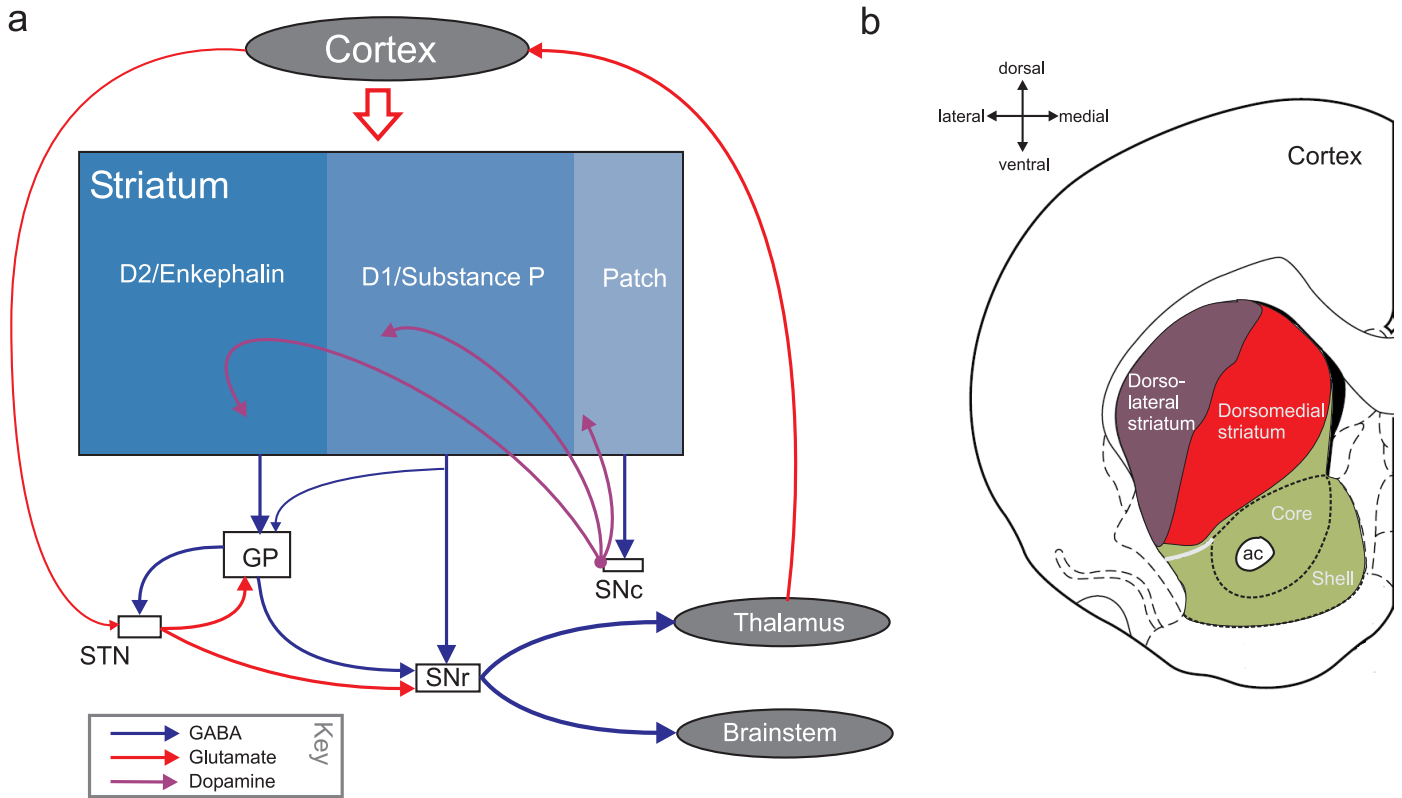

Figure 1: Broad anatomy of the rat basal ganglia. (a) The classic anatomy of the dorsal basal ganglia – grey-shaded structures are outside the basal ganglia. Many sensory, association, and prefrontal cortical areas project to the striatum. The striatum is divided into three populations of medium spiny neurons (MSNs) by target type. A minority make up the so-called “patch” population and target only dopaminergic cells in the brainstem, particularly in substantia nigra pars compacta (SNc). The rest of the MSNs comprise the “matrix” around the patches, which is divided equally between MSNs that project to the globus pallidus (GP) and those that project to substantia nigra pars reticulata (SNr) and entopeduncular nucleus (not shown) – with some of the latter MSNs also sending a collateral to GP. This MSN split by target also seems to correlate with their other properties: GP-projecting MSNs predominantly express D2 dopamine receptors and enkephalin; SNr-projecting MSNs predominantly express D1 dopamine receptors and substance P and dynorphin. The controversy of D1 and D2 split populations is discussed further in the text. Patch MSNs are a mixture of substance P and enkephalin expressing neurons (Gerfen and Young, 1988), and hence likely to correspond to a mixture of D1- and D2-dominant neurons. The small subthalamic nucleus (STN) also receives cortical input from similar regions, and is the only intrinsic source of glutamate in the basal ganglia. It forms a negative feedback loop with the GP, and both target the output nuclei, the SNr and the entopeduncular nucleus (only the former is shown). The SNr targets thalamic and brainstem regions; entopeduncular nucleus, though much smaller, is largely identical to the SNr in neuron type and input structure. The thalamic regions in turn project back to cortical regions from which the cortico-striatal projection originated, forming a closed loop. Rectangular box sizes are proportional to the number of neurons in each structure (Oorschot, 1996), emphasising the dominance of the striatum – dorsal striatum contains around 2.8 million MSNs. (b) Approximate locations of the three striatal domains in a coronal section (section outline from Paxinos and Watson, 1998). The dorsolateral domain is roughly defined by the inputs from primary motor and somatosensory cortices; the dorsomedial domain by input from the association cortices. The ventral striatum is mostly comprised of the nucleus accumbens, which is divided into a core, surrounding the anterior commissure (ac), and a shell region. The core is distinguished from the shell by differences in staining density for a number of neurochemicals (Groenewegen et al., 1999c). The white line indicates the approximate border of shell and dorsomedial striatum, defined by the transition between light and dense staining for calcium binding protein (Jongen-Relo et al., 1994). In some versions of this tripartite division, the ventral striatum extends beyond the nucleus accumbens to cover the whole green-shaded region, defined by the principal hippocampal formation input, particularly from the subiculum (Groenewegen et al., 1987).

inputs. The dorsomedial striatum is often defined as the region receiving inputs from the association cortices (in primate, DMS also contains a small visuomotor region receiving inputs from the cortical frontal eye fields Stanton et al., 1988). More accurately, it is effectively the remainder after anatomically defining the ventral striatum.

Anatomically, the ventral striatum is often synonymous with the nucleus accumbens (NAcc). The NAcc is bounded rostrally and laterally by the external capsule, and medially by the septum and the lateral ventricle (Zahm and Brog, 1992; Paxinos and Watson, 1998). Its other borders are less distinct: caudally, NAcc merges with the bed nucleus of the stria terminalis; ventrally, it transitions into the olfactory tubercle (Zahm and Brog, 1992). Finally, the dorsal border with the rest of striatum is not distinguished by a single histochemical criterion, but by combinations that also define the two sub-regions of the NAcc: the core and shell (Zaborszky et al., 1985; Heimer et al., 1991; Groenewegen et al., 1999c).

The core is a region of densely packed cells wrapped around the anterior commissure, bordered medially and ventrally by the shell (Figure 1b). Staining for acetylcholinesterase (AChE) reveals the lightly-stained core of NAcc cells around the anterior commissure, surrounded by dense staining on all sides (Zaborszky et al., 1985; Zahm and Brog, 1992). Staining for calcium-binding protein (calbindin) clearly reveals the lightly-stained shell wrapping around this densely-stained core, with the dense staining continuing up through the dorsal striatum (Jongen-Relo et al., 1994; Groenewegen et al., 1999c). Thus, the AChE and calbindin staining also respectively define the borders between the NAcc core and dorsal striatum and the NAcc shell and dorsal striatum. Moreover, the calbindin staining suggests that the shell dominates in the most rostral reaches of the NAcc, with the core occupying a small lateral region (Jongen-Relo et al., 1994; Groenewegen et al., 1999c). As we will see, the histochemical distinctions between core and shell are further reinforced by differences in their inputs, outputs, and cellular morphology.

The regions of the other basal ganglia nuclei that these striatal domains project to define the corresponding dorsolateral, dorsomedial, and ventral domains of the basal ganglia as a whole. The dorsolateral and dorsomedial basal ganglia domains both have an identical anatomy to that in Figure 1a. A primary task for us here is setting out the detailed structure of the ventral basal ganglia, noting in particular where it departs from the dorsal domains.

But why look at just the ventral domain? First, because the ventral striatum is the target of such a bewildering array of inputs (Mogenson et al., 1980). As will become clear, the ventral striatum is the principal conflux of inputs representing spatial properties of the environment, desired goals, and teaching signals. Accounts of spatial navigation propose that the ventral striatum uses these inputs to select actions required to reach a target location (see e.g. Redish and Touretzky, 1997; Arleo and Gerstner, 2000). On top of these, the ventral striatum receives further inputs contributing to the generation of flexible exploratory behaviour, including representations of stimulus-response relationships and their value, environmental contin-

gencies, and behavioural strategies. Hence accounts of goal-directed behaviour propose the ventral striatum as the locus for using learnt cues to guide behaviour (Pennartz et al., 1994). Second, because existing theoretical and computational models of basal ganglia (e.g. Albin et al., 1989; Gurney et al., 2001a; Humphries et al., 2006) apply well to either dorsolateral or dorsomedial domains — their internal organisation and cellular composition are identical — but cannot be applied to the ventral domain without caveat. The composition of the ventral basal ganglia is unique, and is our first concern here.

### 3. A new functional anatomy of the ventral basal ganglia

Our model for the functional anatomy of the ventral basal ganglia is shown in Figure 2. A “functional anatomy” attempts to describe the connections and nuclei divisions that are key to the putative function of the brain region (more on this below). It leaves aside minor connections between structures, as defined by small numbers of terminals, very minor neuron populations, as defined by percentage composition of a nucleus, and, at this level of analysis, some internal structure of the nuclei, though this is undoubtedly important and will be discussed further. Our model of course builds on much previous work, but is the first full elaboration of the ventral basal ganglia domain we are aware of. Inevitably, box-and-arrow models such as Figure 2 require care in reading: a projection indicates that a large number of cells in a region form synapses in the target region; but projections to multiple targets can originate from neuron populations that only partially overlap, and degrees of overlap are often unknown.

#### 3.1. The core-based basal ganglia circuit

We begin by discussing the basal ganglia circuit defined by the core and its projections (Figure 2c). In most respects, the core division of the NAcc is indistinguishable from the adjacent dorsomedial striatum. The morphology of its neurons are identical in the size, spine density, and orientation of the dendritic field (Meredith et al., 1992, 2008). The core also contains two populations of MSNs that are distinguishable by their dominant expression of D1 or D2 dopamine receptors (Lu et al., 1998; Matamales et al., 2009), and similarly only 6% of MSNs co-express detectable levels of both (Bertran-Gonzalez et al., 2008).

The core’s outputs also follow the same pattern as those of the dorsal striatum, in that its MSNs’ main targets are restricted to intrinsic basal ganglia nuclei. Elegant work by Deniau and colleagues (Deniau et al., 1994, 1996; Maurice et al., 1997, 1999) has established the major part of the circuit shown in yellow in Figure 2a, which is identical to that of the dorsal striatum (Figure 1a). There are projections from the core directly to subdivisions of the SNr (Deniau et al., 1994, 1996), originating exclusively from dynorphin-expressing MSNs (Zhou et al., 2003). Dynorphin, in turn, consistently co-localises with substance P in NAcc MSNs (Zhou et al., 2003), and substance P consistently co-localises with D1 receptors in NAcc MSNs (Lu et al., 1998). All this leads us to deduce that the core-SNr projection is formed by D1-dominant MSNs, exactly analogous to

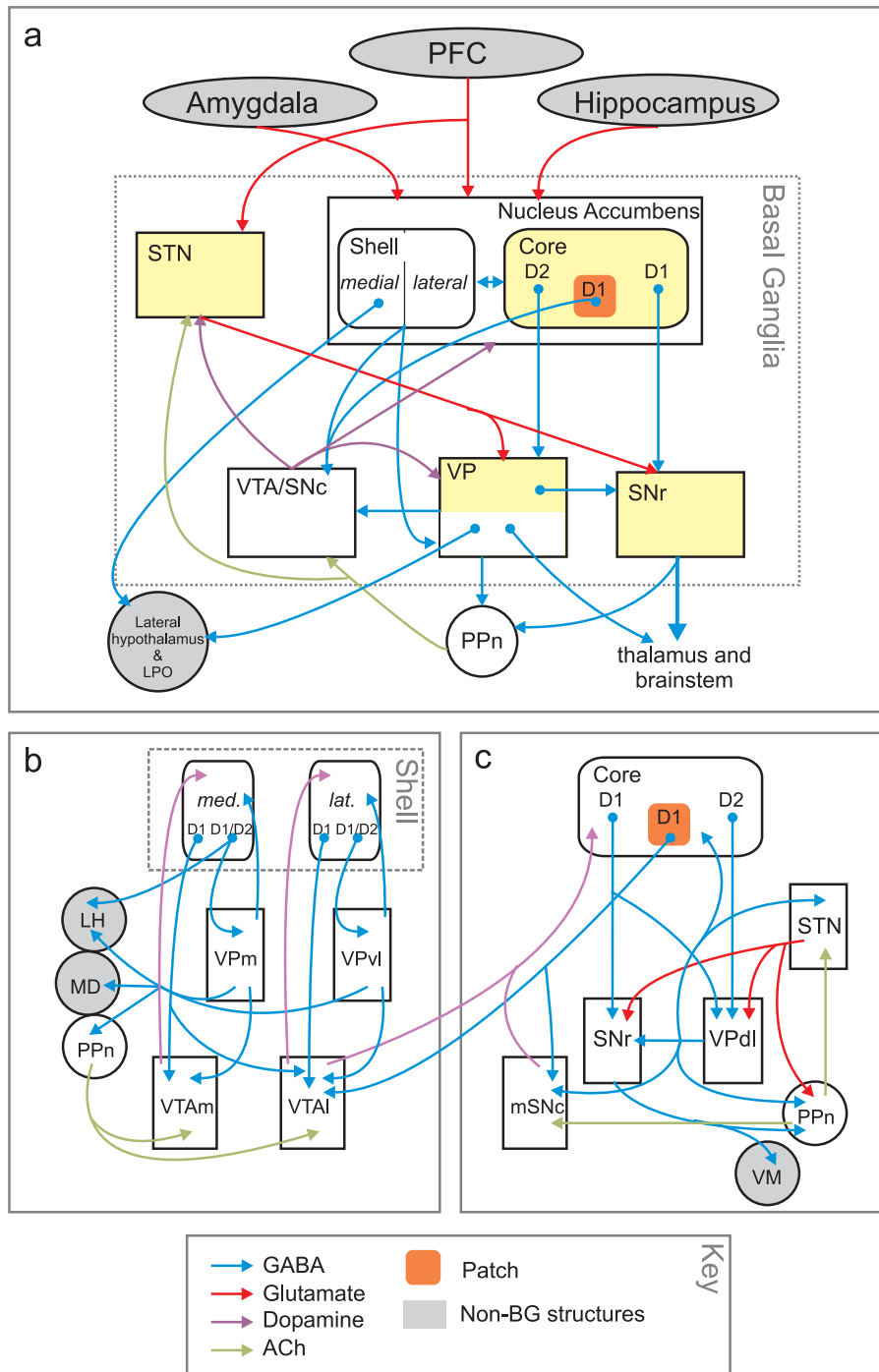

Figure 2: Functional anatomy of the ventral basal ganglia. All arrows beginning with a filled circle indicate that the projection is known to originate from the identified sub-population of cells within that nucleus. (a) Overview of the complete circuit. The nucleus accumbens, predominant part of the ventral striatum, has two major divisions into core and shell regions. The shell in turn has distinguishable lateral and medial sub-divisions. Local axon collaterals and inter-neurons cross the core-shell boundary, probably in both directions. The sub-circuit formed by the structures shaded yellow shares a common architecture with the dorsolateral and dorsomedial basal ganglia domains, as shown in Figure 1a. (The region of VP shaded white corresponds to the sub-regions of VP in panel b). See the Abbreviations list for all structure names. (b) The outputs and inputs of the shell mark it out as unique from the rest of the basal ganglia. Two repeating sub-circuits can be defined based on the inputs and outputs of the medial and lateral shell. Note how both have control over their own dopaminergic input, but that the medial shell also inhibits dopamine cells that project to the lateral shell and core. The projections to the ventral tegmental area (VTA) are made solely by D1-dominant MSNs; the projections to VP are made of D1-dominant and D2-dominant MSNs, and probably all MSNs that express both receptors at roughly equal densities. The mediodorsal thalamus (MD) is the main thalamic target of the VP subdivisions in the shell-based circuit; they also project to lateral hypothalamus (LH) and PPn. (c) The core retains a functional anatomy very similar to that of the dorsal striatum, including: separate targets for D1- and D2-dominant MSNs in the ‘matrix’; a separate population (the ‘patch’) of core neurons projecting to the dopamine cells; reciprocal connections between pallidum and subthalamic nucleus (STN); and overlapping subthalamic and striatal input in the output nucleus SNr. Projections from this region of the SNr primarily target ventromedial (VM) thalamus. It also projects to the PPn, along with the STN, though we do not know if these are the same PPn neurons receiving input from the VP subdivisions in the shell-based circuit. However, there is evidence for separate cholinergic PPn populations projecting to SNc and VTA, as drawn here (Oakman et al., 1995). (We omit VTA dopaminergic input to STN and VP in panels (b) and (c) as the precise region of origin for these projections is unknown; similarly, we omit VTA GABAergic input to the ventral striatum as details of this pathway are sketchy.).

the dorsal striatum's D1-dominant pathway projection to SNr (Gerfen, 2004; Nicola, 2007).

In addition, the core projects to the dorsolateral division of ventral pallidum (VPdl) (Heimer et al., 1991; Maurice et al., 1997), which in turn projects entirely within the basal ganglia, to medial subthalamic nucleus and to dorsomedial SNr, the same area as the direct core projection to SNr (Maurice et al., 1997, 1999; Zhou et al., 2003; Ikemoto, 2007). Again, following a similar organisation of projections to pallidum from the dorsal striatum (Kawaguchi et al., 1990; Gerfen and Wilson, 1996; Wu et al., 2000), this projection has two originating populations in the core. All core MSNs with D2 receptors or enkephalin project to the VP (Lu et al., 1998; Zhou et al., 2003), and we presume these to be largely co-localised. There is also a sub-population of D1/substance P/dynorphin expressing MSNs that project to the VP (Lu et al., 1998; Zhou et al., 2003), and again we presume these to be largely co-localised (i.e. a single population). The D1-dominant sub-population projecting to globus pallidus in the dorsal striatum is comparatively minor; in core it is much larger, possibly larger than the D2-dominant population (Zhou et al., 2003). As noted by Zhou et al. (2003), this could fit well with the VP's seemingly combined role as the ventral equivalent to both the intrinsically projecting globus pallidus and extrinsically projecting entopeduncular nucleus (see below).

Finally, the dorsolateral VP projects back to the core (Hakan et al., 1992; Groenewegen et al., 1993). We propose that it targets the GABAergic interneurons within the 'matrix' (calbindin-rich zones; see below), as does the dorsal domain's pallido-striatal projection (Hanley and Bolam, 1997; Bevan et al., 1998), given the other strong correspondences between the core and dorsal basal ganglia domains. Thus, as indicated in Figure 2, the core-VP-STN-SNr axis is identical in structure to equivalent circuits formed by the dorsolateral and dorsomedial basal ganglia domains.

In turn, the dorsomedial SNr provides the main outlet from the core-based basal ganglia circuit to the rest of the brain. This region of the SNr projects to thalamus, predominantly ventromedial (Deniau and Chevalier, 1985; Groenewegen et al., 1999a) and a region of mediodorsal thalamus (Miyamoto and Jinnai, 1994 [in cat]; Groenewegen et al., 1999a), and the upper brainstem reticular formation, particularly the pedunculopontine nucleus (Kang and Kitai, 1990), similar to the rest of SNr (Deniau and Chevalier, 1992; Deniau et al., 1996). Unlike the rest of SNr, however, the dorsomedial SNr has few projections to the superior colliculus (Deniau and Chevalier, 1992; Deniau et al., 1996).

Some open questions remain. The STN is assumed here to reciprocate the projection from the VP as it does for the projections from equivalent globus pallidus in the dorsolateral and dorsomedial basal ganglia domains, though we are not aware of any strong evidence for this. The relative diffuseness of the STN projections is also unknown in this basal ganglia domain: in the dorsal domains it is thought to project more widely within SNr than the corresponding striatal input (Hazrati and Parent, 1992), and this, as will become clear, forms an important part of some theories of basal ganglia function. Moreover, recent work

has clearly demonstrated a two-layer network structure within GP, with both feed-forward inhibition between layers and feed-back inhibition within layers (Sadek et al., 2007); we do not know if internal structure of the VP follows the same organisation.

### 3.1.1. Patch and matrix in the NAcc core

There has also been some confusion over the existence of equivalent 'patch' and 'matrix' regions in the core to those found in the dorsal striatum (Berendse et al., 1992b; Groenewegen et al., 1999c). Dorsal striatal patches are discrete regions of  $\mu$ -opiate receptor rich, calbindin poor MSNs that project mostly to dopaminergic cells, and receive input from deep layer V of cortex. Dorsal striatal matrix is the surrounding  $\mu$ -opiate receptor poor, calbindin-rich MSNs that form the populations projecting to SNr and GP, and receive input from superficial layer V of cortex (Gerfen and Wilson, 1996). Attempting to define NAcc core 'patches' by histological staining criteria alone is problematic. The caudal core contains discrete calbindin poor regions that could be considered 'patches'. But the rostral core contains discrete calbindin rich regions (Berendse et al., 1992b), and seemingly inverts the normal patch/matrix relationship. Over much of the core, there are also identifiable discrete regions of enkephalin-rich staining, which have also been called 'patches' (Berendse et al., 1992b).

The problem is resolved by considering the conjunction of inputs, outputs, and calbindin-staining. Core MSNs in calbindin poor regions all receive deep layer V cortical input (see section 5), and project to dopaminergic cells (Berendse et al., 1992b) — they are all 'patch'. Core MSNs in calbindin rich regions all receive superficial layer V cortical input (see section 5.2.1), and project to non-dopaminergic cells (Berendse et al., 1992b) — they are all 'matrix'. The confusion arises because of unfortunate discrepancy in the NAcc between the nomenclature — 'patch' invokes an image of a small discrete region of staining — and the definition: in rostral core, the 'patch' as just defined is the *continuous* region.

The core's cellular composition is thus mostly identical to the dorsal striatum. We have found that one exception, on current evidence, is the dopamine receptor composition of the core's 'patches'. The patches of dorsal striatum are made up of both D1- and D2-receptor dominant MSN neuron types (Gerfen and Wilson, 1996), one prominent marker being the mixture of enkephalin-only and dynorphin expressing MSNs in calbindin-poor regions (Gerfen and Young, 1988). Reports of enkephalin-rich, calbindin-poor 'patches' in caudal core (Berendse et al., 1992b) would, at first sight, suggest that D2-dominant MSNs exclusively make up the 'patch' in the core. However, the opposite is more likely: Berendse et al. (1992b) used a leu-enkephalin anti-serum that would have stained all MSNs, as the gene for producing dynorphin also produces enkephalin (Zhou et al., 2003). Zhou et al. (2003) combined retrograde tracing with staining for the genetic precursors of dynorphin and enkephalin to show that only dynorphin-expressing (and therefore probably D1-dominant) MSNs project to dopaminergic cells, and so form the calbindin-poor 'patches' in the core. The dense enkephalin staining found by (Berendse et al., 1992b) in

the caudal core thus seems to correspond to particularly dense neuron clusters of D1-dominant MSNs in the ‘patches’.

The precise nature of the core’s reciprocal connections with the hindbrain dopamine cells is also somewhat unclear. Both the dopaminergic neurons of the SNc and the adjacent, contiguous, ventral tegmental area (VTA) (Bjorklund and Dunnett, 2007), are involved. Projections from the core’s ‘patches’ target medial SNc (mSNc) and, possibly, the lateral ventral tegmental area (VTAI) (Berendse et al., 1992b; Usuda et al., 1998; Zhou et al., 2003). As they originate from GABAergic MSNs, these projections are assumed to be inhibitory, but electrophysiological characterisation of this pathway is lacking (Scarnati et al., 1983). Both core ‘patch’ and ‘matrix’ receive dense projections from the lateral VTA, with a minor projection from medial SNc to the medial core also apparent (Maurin et al., 1999; Joel and Weiner, 2000a). We find that, based on current evidence, a distinction cannot be made between dopaminergic neuron populations targeting the ‘patch’ and ‘matrix’ regions of the core (Joel and Weiner, 2000a), as is often made for the dorsal striatum (Hanley and Bolam, 1997; Joel and Weiner, 2000a). The lateral VTA also projects to both STN and VP, probably via collaterals from some of the fibres reaching the ventral striatum (Smith and Kieval, 2000).

### 3.2. The shell-based basal ganglia circuits

The nucleus accumbens shell is the basis for a circuit unique within the basal ganglia (Figure 2b). Compared to the rest of striatum, its MSNs are significantly smaller<sup>1</sup> (Meredith et al., 1992), have a lower spine density, and have more dopaminergic terminals on the dendritic shafts (Meredith et al., 2008). Groenewegen et al. (1999c) have proposed that the shell has distinguishable medial, intermediate, and lateral regions, partly on the basis of calbindin-binding intensity, but primarily due to the unique sets of inputs and outputs of each region. Here we distinguish only clear lateral and medial divisions on this basis, following others (e.g. Ikemoto, 2007).

There is no discernible ‘patch’ and ‘matrix’ by the criteria given above — all regions of the shell are calbindin-poor. However, like the core, there is a clear distinction in projection targets of the D1- and D2-dominant MSN populations. Mostly dynorphin and substance P expressing (and presumably D1-dominant) MSNs project to the VTA from the shell (Lu et al., 1998; Zhou et al., 2003), and these projections are particularly dense. The lateral shell has reciprocal connections with the lateral VTA (VTAI) and projects to the SNc, just like the core; the medial shell has reciprocal connections with medial VTA (VTAm) and projects to the lateral VTA too (Zhou et al., 2003; Ikemoto, 2007). Thus, medial shell and core/lateral shell form two distinct circuits from the perspective of their connections

<sup>1</sup>Note that smaller MSNs in shell may be explained in at least two ways. A functional interpretation is tempting, as smaller dendritic fields suggest increased specialisation of inputs, that is, each shell MSN is sampling from a smaller array of inputs than other striatal MSNs. But equally possible is that the cause is just mechanical: if the putative functions of the shell require a large number of neurons, then the smaller morphology of the cells increases their packing density.

with the brainstem dopamine cell bands (Figure 2b). These projections may also contact the large sub-population of GABAergic neurons in the VTA (Nair-Roberts et al., 2008), which themselves certainly project back to the NAcc (Carr and Sesack, 2000). As they originate from GABAergic MSNs, the shell projections to VTA are assumed to be inhibitory, but we are not aware of any electrophysiological characterisation of this pathway.

Like the core, the shell projects to the ventral pallidum: medial shell to VP’s medial division (VPM) and lateral shell to VP’s ventrolateral division (VPvl) (Ikemoto, 2007). Electrophysiological studies of NAcc’s projections to the VP consistently report short-latency responses in VP following stimulation in regions corresponding to the shell (Mogenson et al., 1983; Yang and Mogenson, 1985; Hakan et al., 1992; Lavin and Grace, 1996). Moreover, the shell-VP projection is formed, like the rest of striatum, by two MSN populations: one comprising all MSNs expressing enkephalin only, and presumably D2-dominant; the other comprising some MSNs expressing dynorphin/substance P, and presumably D1-dominant (Lu et al., 1998; Zhou et al., 2003). In contrast to the dorsal striatum and core, the D1- and D2-dominant populations projecting to pallidum are roughly the same size (Lu et al., 1998; Zhou et al., 2003). Hence, there are distinct D1- and D2-dominant pathways, VTA receiving input only from D1-dominant MSNs, and D2-dominant MSNs project only to VP.

This picture is complicated by the shell having around 17% of MSNs co-expressing detectable levels of D1 and D2 receptors in BAC mice (Bertran-Gonzalez et al., 2008), far higher than the dorsal striatum (5%) and core (6%). Given the absence of detectable mRNA for D2 receptors or enkephalin in the MSNs projecting to VTA (Lu et al., 1998), it seems likely that the D1/D2 co-expressing MSNs also project to the VP divisions.

The shell striato-pallidal pathway is different from striato-pallidal pathways in the rest of the basal ganglia, as these regions of ventral pallidum in turn project widely outside the basal ganglia (Groenewegen et al., 1993; Pennartz et al., 1994), to lateral hypothalamus (Groenewegen et al., 1993), pedunculo-pontine nucleus (Mogenson et al., 1985; Yang and Mogenson, 1987; Groenewegen et al., 1993) and mediodorsal (MD) thalamus (Groenewegen et al., 1993; Lavin and Grace, 1994) in particular, but not to the SNr or STN. These regions of VP do, however, reciprocate the projection from the shell in a topographic fashion (Groenewegen et al., 1993); again, given the strong similarity with the striato-pallidal circuits in the dorsal domains, we consider it likely that this projection targets the GABAergic striatal interneurons.

The shell is unique within the striatum for having direct outputs to structures outside the basal ganglia. Distinctions within the medial shell can be drawn on this basis: dorso-medial shell projects directly to regions of the lateral hypothalamus (LH) and lateral pre-optic area; ventro-medial shell projects to adjacent regions of the same structures, as well as additional, if comparatively light, projections to the parabrachial nucleus, periaqueductal grey and adjacent areas (Mogenson et al., 1983; Zahm and Brog, 1992; Usuda et al., 1998). We do not know the

dopamine receptor defined MSN populations from which these projections originate. Lateral shell projections seem to remain mostly within the basal ganglia (Usuda et al., 1998).

### 3.3. Common properties of the ventral basal ganglia domain

While the core-based and shell-based circuits have clear differences in input, output, and intrinsic organisation, they nonetheless share some features. The striatal portion of both receives input from the prefrontal cortex, hippocampal formation and amygdala (Pennartz et al., 1994; Groenewegen et al., 1999b): these inputs are dealt with in detail in section 5. They also share some intrinsic features.

#### 3.3.1. The ventral striatal microcircuit

The interneuron composition of the ventral striatal microcircuit may quantitatively differ from that in the dorsal domains. There are repeated claims in the literature (e.g. Gerfen, 2004; Tepper and Bolam, 2004) that the fast-spiking and LTS interneuron classes follow opposite dorsolateral-ventromedial gradients in density, with FS interneurons dominant in dorsolateral striatum, and LTS interneurons dominant in ventromedial striatum (and hence within our main area of interest here). There is good evidence that parvalbumin-expressing neurons show a gradient of decreasing density from dorso-lateral to ventro-medial striatum (Gerfen et al., 1985; Kita et al., 1990; Kubota and Kawaguchi, 1993); and putative fast-spiking interneurons identified from local field potential recordings show the same gradient (Berke et al., 2004). The putative inverse gradient of LTS interneurons is not so clear: on the one hand Desjardins and Parent (1992) report a gradient of increasing somatostatin intensity from the putamen to caudate in primate, but no clear gradient stretching across the dorsolateral-ventromedial axis of the whole striatum; on the other, Kubota and Kawaguchi (1993) report a uniform distribution of neuropeptide Y across the striatum. We conclude that, though there is a gradient of FS interneurons, both FS and LTS classes are undoubtedly expressed throughout the ventral striatum (Husain et al., 1996; Hidaka and Totterdell, 2001). By contrast, despite some suggestions that cholinergic interneurons are uniformly distributed across the dorsolateral-ventromedial axis of the striatum (Gerfen, 2004), comparative studies show there is a higher concentration of cholinergic neurons in the ventral than dorsal striatum (Meredith et al., 1989).

Interconnections within ventral striatum can cross the core-shell boundary. Axons of the cholinergic interneurons extend across the medial shell and core (Meredith et al., 1989). Given their extensive axon fields, and that their axons cross histochemically defined boundaries in dorsal striatum (Kawaguchi et al., 1995), we also expect that the GABAergic interneurons extend their axons across the core/shell boundary. There is also good evidence for direct connections between MSNs in core and shell through their local axon collaterals (van Dongen et al., 2005). Some asymmetry is apparent, as core MSNs project to the whole rostral extent of the shell, whereas shell MSNs have only been observed projecting to the border regions of the core.

A recent study has provided evidence for functional connectivity, showing that these local axon collaterals can induce inhibitory currents in the post-synaptic MSN within NAcc (Taverna et al., 2004). Therefore, in addition to their clearly differentiable areas, outputs, and inputs (see below), core and shell have a plethora of connections between and within them.

#### 3.3.2. Position of the pedunculo-pontine nucleus within the ventral basal ganglia

Common to both core and shell sub-circuits of the basal ganglia is the pedunculo-pontine nucleus (PPn). Though not classically considered part of basal ganglia (Bolam et al., 2000), there have been recent calls for its inclusion (Mena-Segovia et al., 2004; Winn, 2006). These calls reflect the increasing awareness that this small structure plays a key role in both the intrinsic dynamics and output of the basal ganglia, and hence why we include the PPn within our review here. The PPn is as strongly interconnected with the ventral basal ganglia as with the dorsal basal ganglia. It receives direct inputs from regions of VP that receive input from the shell (Mogenson et al., 1985; Yang and Mogenson, 1987; Pennartz et al., 1994), and also has known inputs from STN and SNr (Granata and Kitai, 1989; Pahapill and Lozano, 2000), though it is not clear if these overlap with VP inputs. PPn neurons reciprocate the projection from STN (Hammond et al., 1983), and this loop may play a key role in the motor symptoms of Parkinson's disease (Mena-Segovia et al., 2004). Both show altered activity in animal models of Parkinson's disease (Pahapill and Lozano, 2000; Hammond et al., 2007), PPn lesions cause Parkinson's-like akinesia in otherwise healthy primates (Munro-Davies et al., 1999), and both are targets for therapeutic deep brain stimulation (Jenkins et al., 2005; Hammond et al., 2007). PPn neurons also provide a substantial input to dopaminergic cells in the VTA and SNc (Futami et al., 1995; Floresco et al., 2003), but possibly from separate populations. There is evidence that anterior cholinergic PPn neurons preferentially project to the SNc, whereas posterior cholinergic PPn cells preferentially project to the VTA (Oakman et al., 1995). This separation may be functionally important: there are separable behavioural consequences of anterior and posterior PPn lesions (Wilson et al., 2009); moreover, the cholinergic input from PPn seems to play a critical role in switching dopaminergic cells from pacemaking to burst firing (Kitai et al., 1999; Floresco et al., 2003) – this firing state and its behavioural correlates are central to many theories of the implementation of reinforcement learning in the brain (Montague et al., 2004a).

## 4. Dopamine and the striatum

We review here the types, distribution, and activation effects of dopamine receptors, in part to flesh out some of the above assertions about dopamine receptor expression, in part to provide some understanding of why dopamine has a central place in the ventral striatum research, and in part to underscore the difficulty of relating dopamine to behaviour. We draw from literature across the whole striatum, as the dorsal

and ventral striatum have much in common, and there is a far larger body of work from the dorsal striatum to draw on. Striatum dopamine is our primary concern because the striatum has by far the highest density of dopamine receptors of any structure in the vertebrate brain (Richfield et al., 1989; Richtand et al., 1995). Nonetheless, dopamine plays a role in all other basal ganglia nuclei. Brainstem dopamine neurons project to the STN, VP, GP, and SNr/EP, and D1- and/or D2-like receptors are found in all of them, including autoreceptors on dopamine cells in SNc/VTA (Smith and Kiehl, 2000). An understanding of dopamine's effects in these structures is developing, and with it a shift from striatum-centric theories of dopamine-related diseases. Dopamine loss in the STN-GP loop, for example, is potentially a critical factor in the development of motor disorders (Magill et al., 2001; Bevan et al., 2002; Humphries et al., 2006). We proceed then with the caveat that not all things dopamine-related in the basal ganglia centre on the striatum.

#### 4.1. Types of dopaminergic receptor in the striatum

Some dopamine receptor types in the striatum are clearly established. D1 and D2 receptors are found throughout the striatum, from the dorsolateral tip to the shell (Gerfen et al., 1990; Surmeier et al., 1996; Missale et al., 1998; Bertran-Gonzalez et al., 2008; Matamales et al., 2009). D5 receptors also may be found in low abundance throughout the striatum (Surmeier et al., 1996; Rivera et al., 2002). The D5 receptor may be expressed at low levels by MSNs, and at higher levels by the interneurons (Rivera et al., 2002).

The evidence for D3 and D4 receptors is more mixed. For D3 receptors, mRNA studies show none, and selective ligand studies show very few, in dorsal striatum (Levant, 1997). However, Surmeier et al. (1996) clearly showed the presence of D3 receptors in dorsal striatum MSNs using single neuron RT-PCR. Similarly, D4 receptors have not been labelled in dorsal striatum of D4-selective BAC mice (Noan et al., 2006), nor in mRNA studies in primate (Mrzljak et al., 1996). Again, Surmeier et al. (1996) reported D4 expression in dorsal striatal MSNs using single neuron RT-PCR. We conclude that D3 and D4 receptors are present in dorsal striatum, but at a substantially lower density than was suggested in Surmeier et al. (1996) — it seems that the RT-PCR over-amplified the available genetic material, compared to the density estimates using other techniques. By contrast, there are consistent reports from multiple labs of significant D3 receptor expression throughout the NAcc (Richtand et al., 1995; Moine and Bloch, 1996; Levant, 1998; Schwartz et al., 1998), though not of D4 (Mrzljak et al., 1996; Noan et al., 2006).

#### 4.2. The distribution of dopaminergic receptors in the striatum

Much work on the distribution of dopamine receptors has focussed on whether D1 and D2 receptors are always expressed on separate MSNs (Gerfen et al., 1990) or are co-expressed in a substantial number of MSNs (Surmeier et al., 1992, 1996; Aizman et al., 2000). For the dorsal striatum this seems to have moved towards a conclusion, and one with two answers. First, that D1 and D2 receptors are predominantly found on separate

MSNs (Gerfen et al., 1990; Surmeier et al., 1996). A minority clearly express both at approximately equal densities: single-neuron RT-PCR techniques estimated around 17% of MSNs (Surmeier et al., 1996), but, as noted above, more recent BAC mice studies estimated D1/D2 co-expression at 5% in dorsal striatum, 6% in NAcc core, and 17% in NAcc shell (Bertran-Gonzalez et al., 2008; Matamales et al., 2009). The three populations (D1, D2, and D1/D2 co-expressed) together contain every MSN: each MSN expresses either or both of D1 and D2 receptors (Matamales et al., 2009). Moreover, there is general agreement that the D1 and D2 receptor defined MSN populations do respectively project to the SNr and the GP (Surmeier et al., 1996; Matamales et al., 2009).

Yet, the second answer is that the D1-like and D2-like receptor expressing MSNs are clearly *not* as well segregated. A subset of D2-expressing MSNs also express the D5 receptor, and a subset of the D1-expressing MSNs also express the D3 and/or D4 receptors (Surmeier et al., 1996), perhaps as high as 70% of the D1 MSN population. Nonetheless, as discussed above, there is clearly a much lower density of D3, D4, and D5 receptors than the D1 or D2 receptors in dorsal striatum. Moreover, recent BAC mice studies have revealed clear morphological and dendritic excitability differences between MSNs expressing D1 and D2 receptors (Gertler et al., 2008; Day et al., 2008). Hence, throughout we classify them as D1-dominant and D2-dominant MSNs.

For the ventral striatum, the picture is further complicated by the comparatively high density of D3 receptor expression by MSNs. Large subsets of D1- or D2-expressing NAcc MSNs co-express the D3 receptor (Moine and Bloch, 1996; Schwartz et al., 1998): a double-labelling study suggests around 22% of NAcc MSNs co-express D2 and D3 receptors, whereas around 33% of core and 54% of shell MSNs co-express D1 and D3 receptors (Moine and Bloch, 1996). Hence their higher density implies potentially greater competition between D1 and D3 receptor activation effects in NAcc than in dorsal striatum (Schwartz et al., 1998). However, as D1 and D2 expression is still considerably greater (Richtand et al., 1995), we continue to classify them as D1-dominant and D2-dominant MSNs.

Expression of post-synaptic receptors by the interneurons is less studied. The cholinergic, LTS, and FS interneurons all express D5 receptors (Rivera et al., 2002). Only the cholinergic interneurons also express the D2 receptor (Bertran-Gonzalez et al., 2008). None express the D1 receptor (Bertran-Gonzalez et al., 2008). We are unaware of any study that has specifically looked for the expression of D3 or D4 receptors by striatal interneurons.

The receptor distribution story is complicated by their pre-synaptic expression in the striatum. Considerable evidence points to D2-like receptors located pre-synaptically on glutamatergic (Hsu et al., 1995; Cepeda et al., 2001; Bamford et al., 2004), GABAergic (Pisani et al., 2000; Centonze et al., 2003; Guzman et al., 2003), cholinergic (Pisani et al., 2000), and dopaminergic (Benoit-Marand et al., 2001) axon terminals in the striatum. Some of the GABAergic terminals originate from MSN local axon collaterals within striatum (Wong et al., 1999; Guzman et al., 2003; Mizuno et al., 2007; Tecuapetla et al.,

2007), and hence may well express the same receptors found in the particular MSN's dendrites, including the co-localisation of D1- and D2-like receptors (Wong et al., 1999). GABAergic terminals originating from FS or LTS interneurons may also express D2-like receptors (Pisani et al., 2000), even though these are not detected in the soma-dendritic part of the neuron (Bertran-Gonzalez et al., 2008). Unique to the NAcc is the expression of D1-like pre-synaptic receptors on some glutamatergic terminals (Dumartin et al., 2007).

#### 4.3. The effects of of dopaminergic receptor activation in the striatum

The effects of dopamine receptor activation have been equally controversial (Nicola et al., 2000). Nonetheless, *in vitro* studies of dopamine receptor activation effects on individual MSN ion channels are largely consistent between studies and across the whole striatum (Moyer et al., 2007; Surmeier et al., 2007). Moreover, the individual channel effects for each dopamine receptor mostly have the same ultimate effect on the MSN's excitability. The set of ion channels modulated by D1-like receptor activation tend to decrease excitability when the MSN is already hyperpolarised, but increase excitability when the membrane potential is already depolarised (Moyer et al., 2007; Surmeier et al., 2007). The set of ion channels modulated by D2-like receptor activation tend to decrease MSN excitability (Surmeier et al., 2007). These are not immutable rules. For example, the D2-like dependent reduction in Na<sup>+</sup> current does indeed reduce the excitability of the MSN, probably via D3 receptors; yet a minority of MSNs also show an increase in Na<sup>+</sup> current following D2-like receptor activation, probably via D2 receptors (Surmeier et al., 1992).

Studies of post-synaptic dopamine receptor activation effects on other synaptic input to MSNs are also largely consistent (Moyer et al., 2007; Surmeier et al., 2007). Activation of D1-like receptors enhances NMDA-receptor induced excitatory post-synaptic potentials, but is dependent on co-active L-type Ca<sup>2+</sup> channels (Surmeier et al., 2007). Activation of D2-like receptors decreases AMPA-receptor induced excitatory post-synaptic potentials (Hernandez-Echeagaray et al., 2004).

In comparison to the breadth of literature for the MSN, researchers have barely started documenting post-synaptic effects of dopamine on the striatal interneurons. D1-like agonists depolarise both FS (Bracci et al., 2002; Centonze et al., 2003) and LTS (Centonze et al., 2002) interneurons, presumably acting via the D5 receptors. Evidence from the equivalent cortical FS interneurons suggests that this depolarisation is a result of the suppression of a range of K<sup>+</sup> currents (Gorelova et al., 2002). Both D1-like and D2-like agonists affect the cholinergic interneurons, in keeping with their expression of both D5 and D2 receptors. D1-like agonists depolarise the neuron (Pisani et al., 2000), increasing its excitability, but seemingly counteracted by an enhanced membrane afterhyperpolarisation (Bennett and Wilson, 1998). D2-like agonists reduce Na<sup>+</sup> currents, slowing the interneuron's autonomous spiking (Maurice et al., 2004), and reduce a hyperpolarisation-activated I<sub>h</sub> current, also extending the afterhyperpolarisation (Deng et al., 2007). We are

unaware of any studies that have reported the effects of post-synaptic dopamine receptor activation on other synaptic input to the striatal interneurons.

Whether by co-application of agonists or of just dopamine itself, the effects of simultaneous D1- and D2-like receptor activation on MSN excitability are not well understood. Interpreting most *in vivo* and *in vitro* studies is difficult because of the many potential indirect effects of dopamine, via receptors either on pre-synaptic terminals or the interneurons. For example, we have recently demonstrated that a simulated network of MSNs and FSIs<sup>2</sup> predicts an increase in MSN output and a decrease in FSI output with increasing tonic dopamine (Humphries et al., 2009). On the face of it, this fits well with a simple story of decreased FSI inhibition of the MSNs. Yet there were two unintuitive, network dependent, effects at work: first, that FSI output decreased despite dopamine having an overall excitatory effect on the individual FSI; second, that the MSN output increase was much smaller *without* the FSI input (Humphries et al., 2009). Such combinations of dopamine's effects at the network level can become impossible to predict without computational models.

Attempting to translate documented *in vitro* effects into an *in vivo* picture of dopamine's effects on MSN activity is challenging. As well as the complication of local-circuit effects, the pattern of cortical activity driving MSN firing is different for different anaesthetics, and changes between synchronised and desynchronised states in different ways for each anaesthetic (Mahon et al., 2001). Thus, without simultaneous tracking of cortical afferent drive, *in vivo* study of dopamine's effects on MSN excitability is of limited use.

The few *in vitro* studies that either mechanically (Surmeier et al., 1992, 1996) or pharmacologically (Hopf et al., 2003) isolated the MSN from its afferent inputs have demonstrated that D1- and D2-like receptor agonists can affect the same neuron. Hopf et al. (2003) showed that co-activation can lead to co-operative effects on individual ion channels and hence on MSN excitability. However, the well established intra-cellular signalling pathways in the MSN suggest that simultaneous D1 and D2 receptor activation is more likely to create competition. They oppositely regulate cAMP and, ultimately, the phosphoprotein DARPP-32, which is critical for up- and down-regulating many of the MSN's key ion channels and synaptic receptors (Greengard et al., 1999). Again, it seems a nuanced understanding of simultaneous post-synaptic dopamine receptor activation on the isolated MSN will require computational modelling of the intra-cellular pathways (Fernandez et al., 2006; Lindskog et al., 2006).

Pre-synaptic effects of dopamine receptor activation are less established than the post-synaptic effects. The only consistent finding is that activating pre-synaptic D2-like receptors suppresses vesicle release. This seems to reduce post-synaptic current elicited at glutamatergic cortico-striatal synapses (Cepeda et al., 2001; Bamford et al., 2004; Brady and O'Donnell, 2004; Goto and Grace, 2005), at GABAergic MSN-MSN synapses via

---

<sup>2</sup>Both MSN and FSI neuron models had post-synaptic dopamine modulation of synaptic input and ion channels.

local collaterals (Guzman et al., 2003), and at GABAergic and cholinergic synapses on cholinergic interneurons (Pisani et al., 2000). Similarly, activating D2-like receptors on dopaminergic terminals suppresses dopamine vesicle release (Benoit-Marand et al., 2001). The effects of pre-synaptic D1-like receptors at the MSN-MSN synapses may be facilitatory: their activation can increase the magnitude (Guzman et al., 2003; but see Taverna et al., 2005) and decrease the short-term depression of the post-synaptic current (Tecuapetla et al., 2007).

The action of the unique pre-synaptic D1-like receptors on glutamatergic terminals in NAcc is not immediately clear. The *in vitro* studies consistently report that post-synaptic potentials elicited in MSNs by stimulation of hippocampal or amygdaloid afferent fibres are attenuated by D1-like agonists (Pennartz et al., 1992; Charara and Grace, 2003), suggesting a suppression of vesicle release. Similarly, in preparations that are likely to observe only pre-synaptic effects, application of dopamine attenuates excitatory post-synaptic potentials in NAcc MSNs (Nicola and Malenka, 1998). Whereas *in vivo* studies under urethane anaesthetic report that D1 antagonists attenuate the MSNs' response to the same stimulation (Floresco et al., 2001a), suggesting the opposite. However, as this study reported D1- and NMDA-dependent potentiation over long time-scales, after minutes of repeated stimulation, it is likely the results reflected the key role of D1 and NMDA receptors in synaptic plasticity (section 4.3.1), and not the short-term effects on the terminals. Hence, we believe the current evidence points to a suppressing role for pre-synaptic D1 receptors at NAcc glutamatergic synapses. Moreover, the studies using hippocampal and amygdala afferent stimulation report no effect of D2-like agonists (Pennartz et al., 1992; Charara and Grace, 2003), whereas the studies of prefrontal cortex stimulation report no effect of D1-like agonists (Brady and O'Donnell, 2004; Goto and Grace, 2005). We thus suggest that the terminals originating from prefrontal cortex express only D2-like receptors, consistent with cortical synapses throughout the striatum, whereas the terminals originating from the amygdala and hippocampus express only D1-like receptors.

These differences in pre-synaptic dopamine receptor type could translate into differences in excitability, dopamine concentration, and synaptic plasticity. For the same tonic dopamine concentration, prefrontal cortical input to MSNs may be more suppressed than hippocampal or amygdala input, because D2 receptors have a higher affinity for dopamine than D1 receptors (Richfield et al., 1989). The presence of different dopamine receptor types may also translate into different capacities for forms of synaptic plasticity that depend on pre-synaptic mechanisms (Malenka and Bear, 2004).

#### 4.3.1. Dopamine and synaptic plasticity

Indeed, it is clear that dopamine receptor activation plays a complex role in controlling plasticity at cortical synapses with MSNs (Nicola et al., 2000; Reynolds and Wickens, 2002; Calabresi et al., 2007; Shen et al., 2008). A useful framework for dopaminergic control of corticostriatal plasticity was put forward by Wickens and colleagues, from a synthesis of a decade or so of research (Reynolds and Wickens, 2002). The frame-

work has two components. First, that corticostriatal plasticity requires three factors: pre-synaptic cortical activity, post-synaptic MSN activity, and dopamine. Second, that the concentration of dopamine determines the sign of plastic change: low concentrations induce long-term depression (LTD) and high concentrations induce long-term potentiation (LTP) – so long as the MSN is sufficiently activated. In a further finesse, it has long been thought that D1-like receptors are necessary for LTP, while D2-like receptors are necessary for LTD (Surmeier et al., 2007).

The compactness of this story of course belies the complexities of the mechanisms involved. One form of D2 dependent LTD is mediated via the cholinergic interneurons (Wang et al., 2006). Post-synaptic D2 receptor activation reduces their activity, the corresponding reduction in acetylcholine reducing activation of muscarinic receptors on the MSN. Calcium influx into the MSN rises, ultimately enhancing endocannabinoid release, whose migration back across the synaptic cleft to the corticostriatal terminal activates pre-synaptic receptors that suppress vesicle release. Hence D2 receptor activation does indeed lead to LTD at corticostriatal synapses.

The neatness of this story is also challenged by recent attempts to identify all contributors to corticostriatal plasticity that solely act on the post-synaptic MSN or the pre-synaptic terminal (Shen et al., 2008). Shen et al. (2008) showed that the temporal ordering of pre- and post-synaptic activity matters as much as dopamine concentration, and interacts with both the dominant dopamine receptor of the MSN, and the other receptor types they express. They reported that D2-dominant MSNs show standard spike-timing dependent plasticity: pre-then-post synaptic activity causing LTP, post-then-pre causing LTD, and either alone causing no change. They also reported that applying D2 agonists alone reversed the effect of pre-then-post activity, reliably causing LTD. All forms of LTD required D2 receptors; LTP required NMDA receptors and the adenosine A2a receptor, which is only expressed on D2-dominant MSNs. The D1-dominant MSNs, by contrast, did not show standard spike-timing dependent plasticity: pre-then-post activity caused LTP, but post-then-pre or either separately caused no change. The post-then-pre sequence of activity could only induce LTD following complete dopamine depletion or D1-like receptor blocking. This work suggests altering both components of the framework. Dopamine is not a necessary factor for corticostriatal plasticity – LTP in D2 MSNs and LTD in D1 MSNs does not require it – and hence the direction of plasticity is not a function of dopamine concentration but of the timing of pre- and post-synaptic activity. Nonetheless, the results are consistent with changes in dopamine concentration changing the predisposition of cortico-striatal synapses to show LTD or LTP, but dependent on the dominant dopamine receptor of the post-synaptic MSN.

## 5. Information carried by the primary inputs to the ventral basal ganglia

The ventral striatum has a common input structure with the dorsal striatum, as both receive input from neocortex, thalamus,

and the dopaminergic neuron bands of the brainstem. Neocortical input originates mostly from prefrontal cortex, which extends its projections across the dorsomedial striatum too. What makes ventral striatum unique is its inputs from the hippocampal formation and basal amygdala complex (though the latter extends a little into dorsomedial striatum). If we are to understand the computational roles of the ventral basal ganglia, this naturally leads us to ask: what information are these inputs carrying and combining? We can identify putative informational content carried by the inputs from two lines of attack. First, from behavioural and task-stage correlates of neuron activity in those input structures. Second, from the detailed anatomy of the overlap and segregation of these inputs to the ventral basal ganglia.

To this end, we present here the first comprehensive schematic of inputs to the ventral striatum, covering all three axes (rostral-caudal, dorsal-ventral, medial-lateral) of organisation. Figure 3 summarises the organisation of inputs to the ventral striatum from hippocampal formation (subiculum, CA1 fields of hippocampus proper, and entorhinal cortex; da Silva et al., 1984; Groenewegen et al., 1987; McGeorge and Faull, 1989; van Groen and Wyss, 1990; Boeijinga et al., 1993; Totterdell and Meredith, 1997; Mulder et al., 1998; Groenewegen et al., 1999c,b), amygdala (primarily its basolateral complex — see below; Wright et al., 1996; Mulder et al., 1998; Groenewegen et al., 1999b; Olmos et al., 2004), and prefrontal cortex (Berendse et al., 1992a; Montaron et al., 1996; Maurice et al., 1999; Groenewegen et al., 1999c; Uylings et al., 2003). Using this as our guide, the following briefly reviews the main hypotheses for the functional roles of these regions, as well as for the dopaminergic and thalamic inputs.

### 5.1. The hippocampal formation inputs

The hippocampal formation is a collection of structures with key roles in episodic memory and spatial navigation. Following Witter and Amaral (2004), we consider the hippocampal formation itself to be the C-shaped structure comprising the dentate gyrus, fields CA1 and CA3 of the hippocampus proper, and the subiculum. We also discuss the role of the entorhinal cortex here, as it is so intimately interconnected with the hippocampal formation. Figure 4 is a simplified model of hippocampal formation anatomy, providing context to the following discussion of projections and behavioural correlates.

#### 5.1.1. Detail of the hippocampal formation input to ventral striatum

Hippocampal formation projections from subiculum (Sub) and CA1 target the shell (Figure 3a). Axons from these structures form part of the fimbria/fornix fibre bundle, and so share a similar topography of termination (Swanson and Cowan, 1977). However, it is clear that, of the two, the subiculum is the dominant provider of fibres to the bundle, and hence of inputs to NAcc in rat (Kelley and Domesick, 1982; Groenewegen et al., 1987) and primate (Friedman et al., 2002). There is some evidence that only ventral CA1 provides any detectable projection from the CA1 region (Swanson and Cowan, 1977; van

Groen and Wyss, 1990). Projections from the dorsal subiculum (dSub), and presumably any arising from its dorsal CA1 counterpart, are notably restricted to the rostral-lateral shell; projections from intermediate (iSub) and ventral (vSub) subiculum terminate throughout the rostral-caudal extent of the shell. Both recognised divisions of the entorhinal cortex project to the shell and core, medial entorhinal cortex (MEC) again notably restricted to the rostral medial shell and medial core, and lateral entorhinal cortex (LEC) projects throughout the rostral-caudal extent of the lateral shell and core (Totterdell and Meredith, 1997). Finally, no region of the hippocampal formation is known to project to the STN (Canteras et al., 1990).

#### 5.1.2. Place fields

The behavioural correlates of hippocampal formation neuron activity have been well-studied. Throughout the CA1 and CA3 fields of hippocampus proper are found ‘place cells’ whose activity correlates with a particular spatial location (O’Keefe and Dostrovsky, 1971; O’Keefe and Conway, 1978) — that location is correspondingly referred to as the neuron’s ‘place field’. The place field encoding of these CA1/CA3 cells is remarkably long lasting, with place neuron encoding of a previously explored environment recalled after intervening months (Thompson and Best, 1990). Conversely, they can re-map to a different position in the same environment if some contextual change occurs, such as moving or changing landmarks (Wiener, 1996; Anderson et al., 2006). Cells with ‘place fields’ have also been recorded in superficial layers of the entorhinal cortex and dorsal subiculum, but these are not context sensitive in a given environment, and may encode the same spatial location in different environments (Wiener, 1996; Redish and Touretzky, 1997; Sharp, 2006). Many of the subiculum cells show joint correlations with head direction and position, leading some authors to suggest that subiculum is the spatial navigation locus of alignment between place coding, local view (i.e. current sensory data), and path integration (Redish and Touretzky, 1997).

#### 5.1.3. Path integration, routes, and grid cells

Path integration is the animal’s use of self-motion cues to keep track of its position in space relative to a fixed location, without reference to external landmarks or internal maps (Etienne and Jeffery, 2004). Such ability has been repeatedly demonstrated across insect and animal species, but only relative to a home-base location (Etienne and Jeffery, 2004; Wallace et al., 2006). That is, unambiguous use of self-motion cues has been observed only by a straight line return trip to a starting position after an outward trip of comparatively more complex or random motion (Etienne and Jeffery, 2004; Wallace et al., 2006). Because of its demonstrated ubiquity in exploration of novel environments (Wallace et al., 2006), it is often assumed that path integration is used constantly as an aid to spatial navigation, whether in reference to a home-base or to some arbitrary landmark (Redish and Touretzky, 1997; Arleo and Gerstner, 2000; McNaughton et al., 2006). This hypothesised extension of path integration should not be confused, though often is, with the ability of animals to deduce new routes between familiar locations on an internal spatial map.

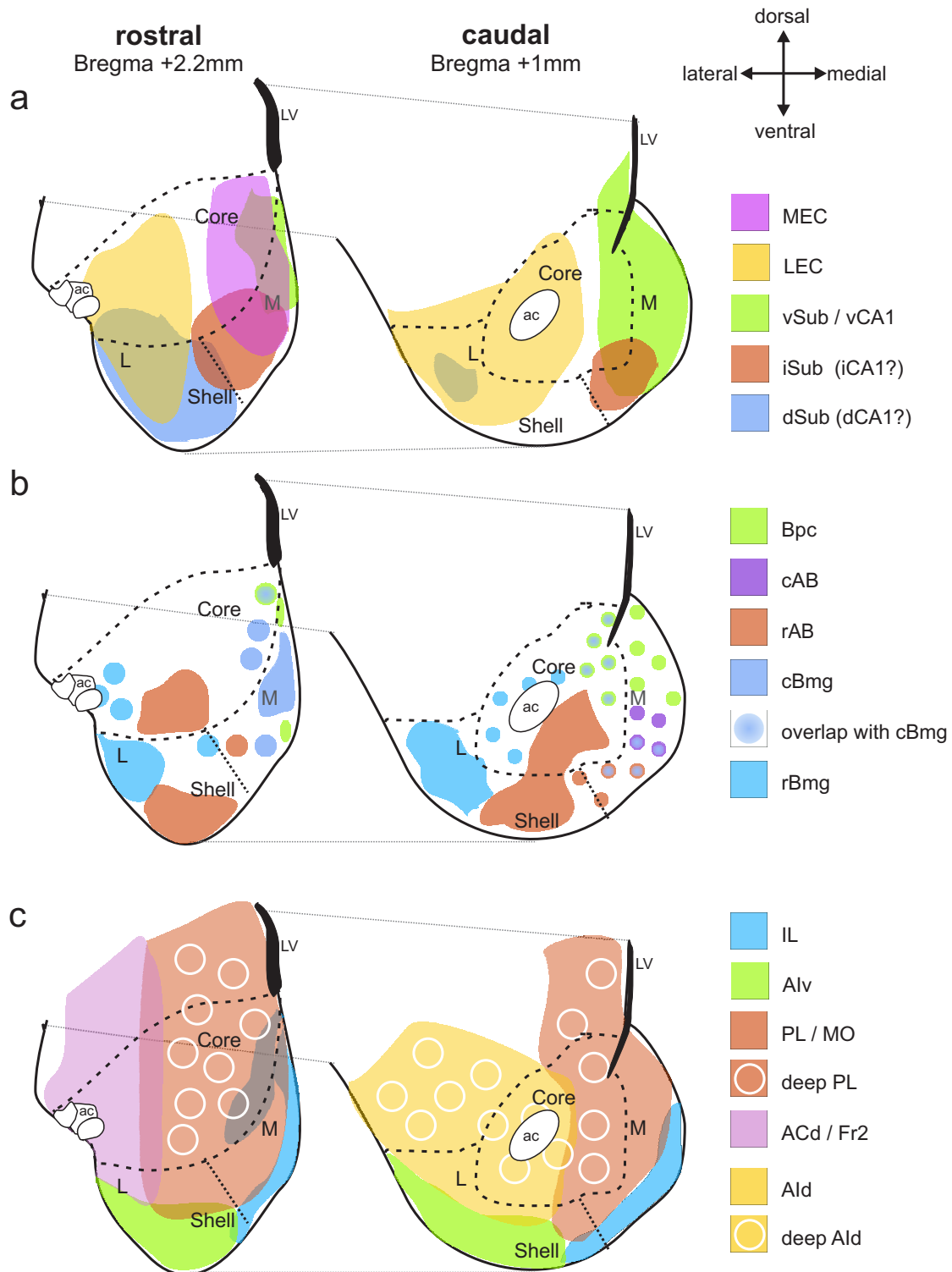

Figure 3: Approximate extent of input fields of the ventral striatum across the rostro-caudal (anterior-posterior) axis. Outlines of nucleus accumbens anatomy from right-hemisphere (left-hand view from front of brain), based on coronal sections from (Paxinos and Watson, 1998), their Figure 10 (rostral) and Figure 14 (caudal). The landmarks of the lateral ventricle (LV) and anterior commissure (ac) are indicated. The shell is divided into two zones, (L)ateral and (M)edial. Note that the various overlapping projection fields define discrete ventral striatal neuron groups with unique sets of inputs. For example, a set of neurons in the ventrolateral shell share inputs from dorsal subiculum (dSub), rostral accessory basal amygdala (rAB), and ventral agranular insular area (AIV) of prefrontal cortex. (a) Inputs from the hippocampal formation and entorhinal cortex. Principal hippocampal formation inputs originate from the subiculum, but some evidence exists for matching (though sparser) inputs from ventral field CA1 of the hippocampus proper. Inputs from the intermediate and dorsal regions of CA1 are not well-described – if they do exist, then they are likely to innervate the same regions of ventral striatum as their equivalent subiculum divisions, due to the preserved topography in the fornix-fimbria pathway. Inputs from the entorhinal cortex cover a larger extent of the core than inputs from the hippocampal formation; the densest region of overlap is formed by the inputs of the ventral subiculum and entorhinal cortex. (b) Inputs from the basolateral amygdala complex. These cover a greater areal extent than those of the hippocampal formation; the densest region of overlap is formed by the inputs of the ventral subiculum and caudal basal amygdala in the medial shell. (c) Inputs from the prefrontal cortex. Fields here show the dominant input to that region of ventral striatum from prefrontal cortex, but most prefrontal cortex areas project sparsely to other parts of ventral striatum. The circled areas denote projections to the ‘patches’ of the core and dorsomedial striatum from deep layer 5 of either prelimbic (PL) or dorsal agranular insular cortex (AId); these are the dominant projections, but all cortical areas sending projections to core reach both ‘patch’ and ‘matrix’ (Gerfen et al., 1987). See list for abbreviations.

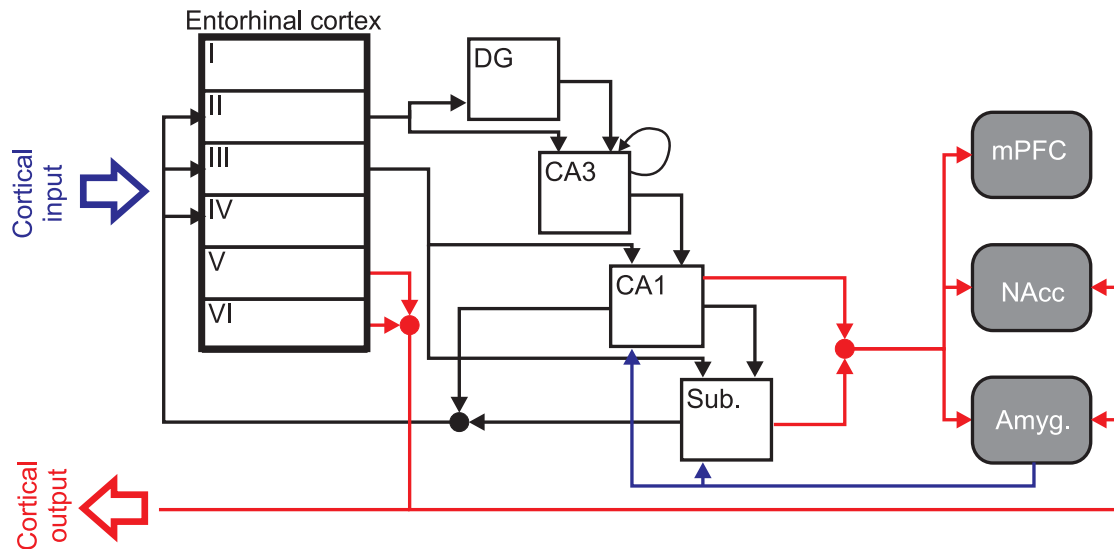

Figure 4: Simplified model of hippocampal formation anatomy and relevant extrinsic connections (see e.g. Witter and Amaral, 2004, for review). Black lines indicate intra-hippocampal connections; blue lines, inputs; red lines, outputs. Grey-shaded structures are external to the hippocampal formation. Entorhinal cortex (EC) is the target of most cortical input to hippocampal formation. In turn, EC layer II projects to dentate gyrus (DG) and region CA3 of hippocampus proper; EC layer III projects to region CA1 of hippocampus proper and the subiculum (Sub). These other hippocampal structures form a feed-forward network DG-CA3-CA1-Sub. The main exception from the feed-forward rule is the abundant recurrent axon collaterals between the pyramidal cells in CA3. Both CA1 and subiculum project back to EC layers II-IV, completing the loop. All of CA1, Sub, and EC layers V and VI project to NAcc (Figure 3a), and some amygdala nuclei (Figure 5). EC output from layer V and VI is the main return pathway of hippocampal formation to the rest of neocortex, but CA1 and subiculum have separate direct projections to medial prefrontal cortex (mPFC) (Witter and Amaral, 2004; Cenquizca and Swanson, 2007). However, only the amygdala nuclei reciprocate the projections from CA1 and subiculum (Witter and Amaral, 2004).

New route deduction forms the basis for the ‘cognitive map’ theory of hippocampal function (Tolman, 1948; O’Keefe and Burgess, 2005), that the hippocampal formation is the internal spatial map animals use to deduce new routes without reference to their external surroundings (i.e. by ‘cognition’ alone). The demonstration of place cells buttressed this theory considerably as they provide the necessary neural coding to form the basis for that deduction. Unfortunately, the behavioural evidence that animals can do route deduction is weak (Bennett, 1996); even humans seem unable to perform this when external landmarks are removed (Foo et al., 2005). To reiterate, path integration is self-motion guided navigation with reference to some start location, route deduction is internally guided navigation with reference to an internal spatial map; there is excellent evidence for the former (Etienne and Jeffery, 2004), but controversial evidence for the latter (Bennett, 1996).

Nonetheless, there is an internal spatial map, and recent studies have revealed the existence of a universal metric of space that was a key component of computational implementations of the cognitive map theory (McNaughton et al., 2006). Cells within layers II, III, and V of medial entorhinal cortex have place fields that repeat at regular spatial intervals, each neuron covering a large spatial area with a tessellating rhomboid (or double triangle) pattern of place fields (Hafting et al., 2005). These ‘grid cells’ occur with different spatial scales, so that they appear to form a metric of space at overlapping scales. Moreover, some layer III and V cells also show a conjunction of head direction selective activity and tessellated place field (Sargolini et al., 2006). The discovery of grid cells has sparked a range of new theories for the generation of path inte-

gration (McNaughton et al., 2006)<sup>3</sup>. Perhaps most interesting is that the combined output of grid cells at multiple spatial scales could provide a unique read-out of spatial location, and the hippocampal CA1/CA3 place fields are themselves a read-out of this combined output (McNaughton et al., 2006; Rolls et al., 2006; Fiete et al., 2008).

#### 5.1.4. Spatial navigation or memory?

Hippocampus research in rodents is dominated by spatial navigation; in primates, by episodic memory. Some have reasonably suggested that the hippocampus is not just a “memory for space”, but rather a more general “memory space” (Eichenbaum et al., 1999) for the storage of repeated episodes of experience, of which spatial location is but one aspect. Considerable evidence exists for the sensitivity of CA1/CA3 place field encoding to a broad range of contextual changes. Colour, pattern, shape, even odour changes can all trigger partial re-mappings of place fields (Wiener, 1996; Eichenbaum et al., 1999; Anderson et al., 2006). Context encoding extends beyond sensory aspects too: Mizumori and colleagues (Smith and Mizumori, 2006a,b) have shown that changes in task demands within an otherwise identical plus-maze environment partially re-maps the place fields in CA1/CA3, and that numerous cells show

<sup>3</sup>These new theories, like their predecessors, generally address only the combination of self-motion cues and head direction into a continuously updated representation of current location i.e. the outward leg of the path integration process; while capable of impressive results (Samsonovich and McNaughton, 1997), they do not currently address the best evidence for path integration itself i.e. how the path back to the home-base is computed based on current displacement from it.

conjunctions of place field and task-stage activity in one task set-up, but not in another. Replay of experienced behavioural sequences has also been observed in the activity of hippocampal formation neurons. During slow-wave sleep groups of place cells replay their activity patterns in the same sequence they fired during awake behaviour (Lee and Wilson, 2002). In awake rats, *reverse* replay of place-cell sequences occurs during rests between maze runs (Foster and Wilson, 2006). And repeated cell-assembly firing sequences are reliably elicited in rats performing memory-dependent tasks from the same initial conditions, and different conditions result in different sequences (Pastalkova et al., 2008). There is little doubt that the hippocampus is more generally a memory space than a spatial map, though this is not universally accepted because of the co-existence of place fields with sensory input and task-stage related activity (O’Keefe, 1999).

We follow here this stronger hypothesis for the role of the hippocampal formation: it is a substrate for episodic memory, learning sequences of events that happen to the animal <sup>4</sup>, and the context in which those events occur (Eichenbaum et al., 1999; Morris, 2006). We contend that the focus on spatial maps is forced because the rat is the laboratory animal of choice. Locomotion is its primary means of finding information about the world in an open environment, as its highly acute senses are either localised (active touch via whiskers) or have comparatively poor spatial resolution (e.g. audition, olfaction Burn, 2008). Thus, as locomotion is its primary model of exploration, changes in location are the consistent element of hippocampal memory representations in rodents. The learning of routes is then just the correct re-sequencing of events to achieve the desired target location.

Finally, we note that behavioural, contextual, or spatial correlates of activity in both lateral entorhinal cortex, and its targets in ventral subiculum are poorly understood (Hargreaves et al., 2005; O’Mara, 2006; Knierim, 2006). This creates some considerable problems as these two structures between them provide most of the hippocampal formation output to ventral striatum (see Figure 3). Spatial correlates of activity in both structure has been reported, but are weak as they are not sustained across recording sessions (Hargreaves et al., 2005; Knierim, 2006). Knierim (2006) advances the plausible but tentative hypothesis that neuron activity in lateral entorhinal cortex may be more correlated with the configuration of visible landmarks, as it is a target of the ventral stream of visual processing. As for the ventral subiculum, O’Mara (2006) notes that putatively blocking synaptic plasticity within it, using D1 receptor antagonists, produces instrumental learning deficits in rats; lesioning it produces severe deficits in acquiring conditioned fear. O’Mara (2006) goes on to propose a role for ventral subiculum as a major controller of the hypothalamic nuclei but, as Swanson (2000) makes clear, there is nothing to distinguish this projection from those of CA1 and CA3 fields to the hypothalamic

<sup>4</sup>This perspective reinforces a cardinal caveat when interpreting neural correlates of behaviour: just because the recorded neuron is active during a particular task stage does not mean that the structure to which it belongs is necessary for that task — if the hippocampus is a memory space, it will be active whether or not its outputs are currently necessary for the task at hand (Morris, 2006).

nuclei. We are left to repeat Knierim’s (2006) exhortation for experimentalists to shift their focus away from CA1 and CA3 fields to the other parts of the hippocampal formation.

## 5.2. Prefrontal cortex inputs

Prefrontal cortex is famously the postulated seat of higher ‘executive’ functions such as planning and attentional control (Miller, 2000). We focus here on its known roles in simple conditioning and spatial learning tasks, as these form the underlying basis from which advanced vertebrates have elaborated “executive” functions, and are of most relevance to the rat.

### 5.2.1. Detail of the prefrontal cortex inputs to ventral basal ganglia

Prefrontal cortex input to the ventral striatum covers the whole region, and some of the projections continue up to cover the dorsomedial striatum too (Figure 3c). The medial prefrontal cortex regions — comprising prelimbic (PL), medial orbital (MO), and infralimbic (IL) areas — together project extensively to the medial core and shell in the caudal half of ventral striatum, and to most of the core and shell in the rostral half; the specific projection of IL cortex is notably restricted to the medial shell. Input from the dorsal anterior cingulate (ACd) and “frontal region 2” (Fr2) areas — the putative rodent homologue of primate dorso-lateral prefrontal cortex (Uylings et al., 2003) — reaches a restricted portion of the rostro-lateral core and shell. Conversely, projections from the dorsal (AId) and ventral agranular insular (AIV) region — the rat homologue of primate orbitofrontal cortex (Uylings et al., 2003; Dalley et al., 2004) — respectively reach only the caudo-lateral and rostro-lateral core and shell. Of particular note is that projections to the core from prelimbic and dorsal agranular insular cortex show a distinct pattern: projections from superficial layer V in the areas predominantly target the ‘matrix’, whereas projections from their deep layer V predominantly target the ‘patches’ (Berendse et al., 1992a). These deep layer V projections thus uniquely overlap with most of the amygdala input to the core.

Inputs to the subthalamic nucleus are known only from a restricted area of prefrontal cortex, primarily the prelimbic and adjacent medial orbital areas (Canteras et al., 1990; Maurice et al., 1998), the same regions providing the dominant cortical input to the core.

### 5.2.2. Correlates of strategies and goals in medial prefrontal cortex

The medial prefrontal cortex, particularly the prelimbic and infralimbic areas, has been implicated in two seemingly unrelated processes in conditioned learning (Cardinal et al., 2003). First, the representation of action-outcome contingencies, the determination of the probability of a reward given a particular action. For example, Coutureau and Killcross (2003) showed that a lesion of prelimbic cortex can leave the expression of learnt action-outcome contingencies intact, but only if the action was primed by an associated stimulus; otherwise the rats were unable to show a connection between contingency and action, suggesting prelimbic cortex is a working memory for

action-outcome based sequencing. Second, the suppression of learnt associations between conditioned and unconditioned stimuli, which forms the basis for the phenomenon of extinction in conditioning. The distinction is made here between suppression and ‘unlearning’: the spontaneous recovery of previously learnt associations after their apparent extinction strongly suggests that the association is not forgotten, but is suppressed. For example, Peters et al. (2008) showed that inactivating infralimbic cortex prevented suppression of cocaine seeking, whereas over-activating the same structure prevented spontaneous recovery. Corbit and Balleine (2003) showed that intact infralimbic cortex is necessary to suppress the action-outcome contingency system in favour of a rapid-response habit system, suggesting more generally that infralimbic cortex plays a central role in selecting and suppressing *strategies*.

Such a role for medial prefrontal cortex is supported by reports that inactivation of prelimbic/infralimbic cortex prevents switching between self-guided and cue-guided strategies on plus-maze tasks (Ragozzino et al., 1999; Rich and Shapiro, 2007), and by neural recordings from Wiener and colleagues (Battaglia et al., 2006b; Wiener et al., 2007; Peyrache et al., 2009). They recorded large numbers of prelimbic cortex cells while rats learnt and switched between self- and cue-guided tasks on a Y-maze, and found that activity mostly correlated with the current part of the behavioural task. However, after extending their analysis across task switches, they found that a subset of these neurons either increased the magnitude of correlation or shifted their correlates to a different task stage when the animal changed its behavioural strategy on the Y-maze. Thus, this seems to be evidence for an extended form of action-outcome contingency, where the action is a complete behavioural strategy tested by the animal.

Others have recorded correlates of what they termed ‘goals’ in prelimbic/infralimbic cortex (Hok et al., 2005). A large number of recorded cells had place-specific firing in an open arena for either a “target zone”, where the rat had to stop to release food, or “reward zone” where the food was placed: these cells did not show the same correlate with the spatial location when the rat was randomly foraging, only during the task. Thus, while the designation ‘goal’ is a little imprecise<sup>5</sup>, some cells in prelimbic/infralimbic cortex clearly signal the successful attainment of a task stage — a successfully achieved goal, if you will; in their tasks Wiener and colleagues (Battaglia et al., 2006a; Wiener et al., 2007) also recorded some reward-specific prelimbic cells in their Y-maze, which may be the corresponding representation in maze tasks.

### 5.2.3. *Correlates of incentive value in orbitofrontal cortex*

The agranular insular parts of rodent orbitofrontal cortex project to the core and shell, and so we discuss some aspects of orbitofrontal behavioural correlates here, with the caveat that most studies do not distinguish the agranular areas from the

<sup>5</sup>For it to be an active representation of a goal, the neuron would show activity correlating to that place *before* reaching it; these presumably would be cells that fire continuously from the outset of a task stage until the goal is reached, and which show no correlation with direction of movement.

ventral and lateral orbital areas (Dalley et al., 2004). Primate work on orbitofrontal cortex has drawn attention to its role in representing and computing expected incentive values of actions, i.e. the anticipated value to the animal of performing that action, and as such forms part of the proposed neural substrate for reinforcement learning (Schultz et al., 2000; Cardinal et al., 2003).

Rodent studies are few, but broadly consistent with the primate work. Dalley et al. (2004) suggest that rodent orbitofrontal cortex is necessary for coping with changes in the delay or magnitude of rewards, an interpretation we think analogous to incentive value in that either of those changes alters the anticipated value of the action that led to the reward (quicker or larger rewards may increase the action’s value; slower or smaller may decrease its value). Feierstein et al. (2006) reported that many cells in rat orbitofrontal cortex fired in correlation with either the location of a target reward receptacle, or with the direction of movement required to get there; a subset of these cells showed conjunctions of target location and trial outcome correlated activity, providing the basis for associating spatial location and reward. Finally, a series of studies by Schoenbaum and colleagues show a clear separation between basolateral amygdala’s role in representing stimulus-outcome value associations, and orbitofrontal cortex’s role in representing how this value is turned into the *current* incentive for associated actions (Schoenbaum et al., 2003).

### 5.3. *Amygdala inputs*

The projections from the amygdala are particularly complicated (Figure 3b), and are further obfuscated by confusing terminology. In their tracing studies, Groenewegen and colleagues discuss all projections with reference to the “basal amygdaloid complex” and its subdivisions, which differs in terminology to standard rat atlases (Paxinos and Watson, 1998; Olmos et al., 2004). Some researchers refer to the “basolateral amygdala complex” or the “laterobasal amygdaloid nuclear complex”, which includes the lateral nucleus, the basal group, and the accessory basal nucleus (LeDoux, 2000; Olmos et al., 2004). Groenewegen and colleagues include only the basal and accessory basal nuclei in their “complex” (Wright et al., 1996). They divided the accessory basal nucleus into rostral (rAB) and caudal (cAB) regions, and divided the basal nucleus into two neuron types, the parvicellular basal complex (Bpc), and rostral (rBmg) and caudal (cBmg) magnocellular basal complex divisions, divisions adopted by some amygdala researchers (Pitkanen et al., 1997), but not others (Olmos et al., 2004). Comparison of the naming schemes suggests that the accessory basal nucleus is approximately equivalent to the basal medial subdivision of the basal nucleus, and the neuron group (parvicellular and magnocellular) divisions all belong to the basolateral subdivision of the basal nucleus (Pitkanen et al., 1997; Olmos et al., 2004).

The amygdala projections notably form clusters within the shell, and those that project to the core mostly target the ‘patches’ — only the rAB projection to the ventral core reaches the ‘matrix’. In addition, no region of the basolateral amygdala is known to project to the STN (Canteras et al., 1990).

### 5.3.1. *Encoding of stimulus value*

The basolateral amygdala complex encodes the absolute value of an unconditioned stimulus associated with a learnt conditioned stimulus (Cardinal et al., 2003). As the amygdala has direct outputs for controlling motor responses to that perceived value, it is often considered the seat of basic emotions within the mammalian brain (LeDoux, 2000). The clearest demonstrations of learnt value of a stimulus association come from studies of aversive conditioning (Davis et al., 1997; LeDoux, 2000). In these, the animal learns to associate an unpleasant stimulus, such as a footshock or loud noise, with a preceding tone, so that the tone itself is capable of eliciting the same fear (to footshock) or startle (to loud noise) response as the stimulus itself. Lesions of the basolateral amygdala prevent these forms of fear conditioning (LeDoux, 2000; Cardinal et al., 2003), as do lesions of the central amygdala, which relays the basolateral amygdala output to the brainstem motor centres. (There is some evidence that the basolateral amygdala is not necessary for contextual fear conditioning i.e. aversion to the environment in which the aversive stimulus was delivered, Cardinal et al., 2003). Further evidence for value encoding comes from studies of devaluation, where an intact basolateral amygdala is necessary for rats to remember the value associated with a particular manipulanda (e.g. lever), so that they may express appropriate behaviour when the reward associated with a manipulanda is devalued (Balleine et al., 2003).

As discussed above the basolateral complex itself comprises sub-nuclei, which each make distinct contributions to the associative processing, and all their outputs are combined in the central amygdala — Figure 5, adapted from (Pitkanen et al., 1997), shows the basic structure. The computations performed within this amygdala circuit are poorly understood compared to the prefrontal cortex and hippocampal formation, and current models are relatively rudimentary (Armony et al., 1997; Lowe et al., 2009).

The amygdala nuclei projecting to the NAcc form only part of the basolateral complex. Neither the lateral amygdala (McDonald, 1991), which receives the primary sensory information about the conditioned stimulus (e.g. the tone), or the medial amygdala, which receives convergent input from the lateral amygdala and the hypothalamus, project to the ventral striatum. The ventral basal ganglia domain is then in direct receipt of only a subset of the associations represented in the basolateral amygdala – though there is a disynaptic path from lateral amygdala to the ventral striatum via AB and Bpc. Moreover, the central nucleus of the amygdala, its primary output station to brainstem (Pitkanen et al., 1997; Par et al., 2004), also does not project to the ventral striatum according to current data (McDonald, 1991; Howland et al., 2002).

### 5.4. *Thalamic inputs*

We omit only thalamic inputs from Figure 3: primarily from divisions of the intralaminar and midline thalamus, they provide input to the same regions of ventral striatum as do their ultimate targets in prefrontal cortex (Berendse et al., 1992a; Groenewegen et al., 1999a,c; der Werf et al., 2002). There are two notable

exceptions. First, the reuniens and rhomboid nuclei of the midline thalamus project very sparsely to the striatum. Second, by contrast, the parafascicular/centromedian complex of intralaminar thalamus projects most densely to the dorsolateral core and adjacent ventromedial striatum, rather than to cortex (der Werf et al., 2002); its input here overlaps with cortical input from ACd/Fr2 rostrally and Ald caudally. In addition, regions of the parafascicular/centromedian complex of intralaminar thalamus project to the STN (Lanciego et al., 2004; Castle et al., 2005).

Changes in thalamic projection patterns along the rostral-caudal axis of ventral striatum are not as well established as those of amygdala, hippocampus, and prefrontal cortex. A small projection from the mediodorsal nucleus of the thalamus to the NAcc core has been described in rat (Mengual et al., 1999; Erro et al., 2002; Smith et al., 2004), though is poorly characterised at present; data from primate suggests that mediodorsal thalamus projections reach only the core, and not the shell (Gimnez-Amaya et al., 1995). This lack of clear characterisation of mediodorsal thalamus inputs to ventral striatum is frustrating, as mediodorsal thalamus is the principal structure closing the cortico-basal ganglia-thalamocortical loop back to prefrontal cortex (Groenewegen et al., 1999a).

The intralaminar thalamic nuclei are a major target of the deep layers of the superior colliculus, and hence provide a disynaptic route between colliculus and ventral striatum (McHaffie et al., 2005). Projections from the parafascicular/centromedian complex arborise densely, individual fibres making multiple contacts with MSNs, and preferentially target substance P colocalising MSNs (those projecting to the SNr) and the cholinergic interneurons (McHaffie et al., 2005). These may thus provide a substrate for allowing highly salient sensory events, detected by the superior colliculus, to quickly affect the computations of the ventral basal ganglia. Consistent with this, neurons of the primate intralaminar nuclei respond to phasic visual and auditory stimuli, and their inactivation completely abolishes the response to these stimuli by putative cholinergic interneurons in the striatum (Matsumoto et al., 2001).

### 5.5. *Dopaminergic inputs*

The functional correlates of dopamine are often considered separately for the phasic and tonic components of dopaminergic neuron firing and corresponding changes in dopamine concentration. The phasic/tonic split also corresponds to differences in the interpretation of dopamine's effects. The phasic component's effects are normally interpreted within the framework of dopamine's role in modulating synaptic plasticity in the striatum, whereas the tonic component's effects are normally interpreted within the framework of dopamine's role in modulating short-term excitability of the striatal neurons. The principal hypotheses we review below certainly fall into this dichotomy, but, as section 4 makes plain, there is little doubt that phasic dopamine also affects short-term excitability and tonic dopamine also affects synaptic plasticity. The complexity of dopamine's actions and receptor distribution in the striatum clearly point to multiple computational roles beyond the foregoing current ideas; elucidating these roles is a prime area for computational modelling.

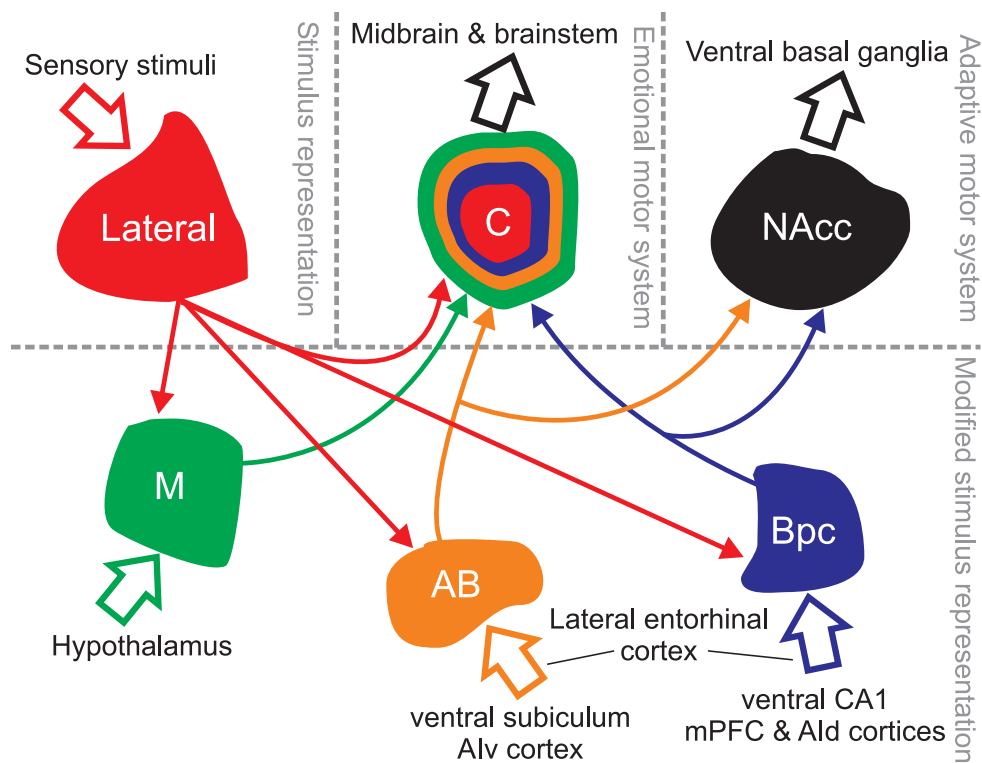

Figure 5: Simplified model of internal amygdala contributions to associative (particularly fear) conditioning and motor control, adapted from (Pitkanen et al., 1997). The basal parvocellular (Bpc) and accessory basal (AB) regions are the main source of projections to the ventral striatum (NAcc). Outputs from these nuclei also converge, along with projections from the medial (M) and lateral nuclei, on the central nucleus (C), which itself projects to brainstem motor centres, particularly those contributing to the emotional motor system (Holstege, 1998). Input from the hippocampal regions and prefrontal cortex is divided between the AB and Bpc regions (McDonald, 1998). Lateral entorhinal cortex projects to both, whereas ventral subiculum particularly targets the AB region. Analogous to hippocampus proper's direct NAcc projection, only ventral CA1 projects to the amygdala. The AIV and AId regions of prefrontal cortex – part of the rodent homologue for primate orbitofrontal cortex – project respectively to AB and Bpc regions.

### 5.5.1. Computational theories of phasic dopamine

Functional correlate research has focused principally on the phasic burst firing of dopaminergic neurons, and the resulting transient increase in striatal dopamine concentration (Montague et al., 2004a). A currently high-profile theory is that the phasic burst of spikes from dopaminergic neurons is a reward prediction error (Schultz et al., 1997; Waelti et al., 2001), representing the difference between the expected and received reward. Certainly, in simple conditioning tasks, the phasic burst is strongly correlated with the reward, transfers to the reward-predicting stimulus over training, and is depressed (the firing rate dips) when the reward or its predicting stimulus (post-training) is omitted (Schultz, 2007). As such, the phasic burst fits nicely into reinforcement learning theory, as the prediction error in the temporal difference learning algorithm (Schultz et al., 1997; Montague et al., 2004a). The sign of the error determines the change in value assigned to the reward or stimulus: positive errors (reward bigger than expected) increase value; negative errors (reward smaller than expected) decrease value. In instrumental tasks, this change in value then changes the probability of selecting the action that elicited the reward or predictive stimulus.

These hypotheses for the phasic burst have in turn led to numerous attempts at mapping the full version of the algorithms onto the basal ganglia's anatomy, particularly the Actor-Critic form of the temporal difference algorithm (Joel et al., 2002), which posits separate representations of error (computed by the Critic) and of action selection (the Actor). Most such models are critiqued for their selective reading of the basal ganglia functional architecture, omitting major pathways and neuron types that, if included, would prevent the algorithm from working (Joel et al., 2002). Some more recent models have attempted to tackle these criticisms (e.g. Khamassi et al., 2005).

A second thread of functional correlate research has focused on dopamine's role in motivation and the related concept of 'incentive salience' (Berridge, 2007). In a comprehensive review Berridge (2007) has argued that there is considerable evidence against the reinforcement learning hypothesis, detailing numerous learning paradigms for which dopamine is seemingly not necessary. Instead, he defends a view of phasic dopamine as an 'incentive salience' signal: the signal to keep maintaining or repeating the current action, as long as it is worthwhile — the signal for 'wanting', as he puts it. This nicely explains the pattern of phasic dopamine signalling detailed above (reward achieved, so increase motivation to repeat/maintain; reward omitted, decrease motivation), while also accounting for slower but evident learning in some paradigms following dopamine depletion.

A third recent proposal (Redgrave and Gurney, 2006) is based on a different critique of the reward prediction error hypothesis, that the consistently small time delay between reward delivery and the onset of the phasic dopamine burst (~ 70 – 100 ms) is too short for the animal to be able to compute the value of the reward, and thus has no basis for computing an error signal (Redgrave et al., 1999a). Instead, Redgrave and Gurney (2006) proposed that the phasic dopamine signal acts as a time stamp for the occurrence of any salient stimulus, rewarding or

otherwise, so that the conflux of motor commands from cortex and dopamine in the striatum will allow the association of the action produced by the animal, if any, with that outcome. Via dopamine's modulation of corticostriatal plasticity, this in turn will bias future selections of that action, to either confirm or refute the association between that action and the outcome. Thus, the phasic dopamine signal can be seen as having a key role in assigning internal causality to the animal's actions, and in differentiating internal from external causality for outcomes, ultimately building a repertoire of action-outcome knowledge.

All proposals that interpret the phasic burst of spikes by dopaminergic neurons as a signal for plasticity have two unaddressed biological issues. First, that synchronised firing across many dopaminergic neurons is required to elicit the phasic change in dopamine concentration (Gonon, 1997; Venton et al., 2003; Montague et al., 2004b). Electrophysiological studies are generally restricted to single-unit recordings (e.g. Schultz et al., 1997; Waelti et al., 2001; Bayer and Glimcher, 2005) or report only two or three units from a single animal (e.g. Roesch et al., 2007), and so have not shown that multiple dopaminergic neurons simultaneously have the same firing pattern in response to the reward, the predictive stimuli, and their omission. However, indirect support for the simultaneous bursting of multiple dopaminergic neurons has come from studies using fast-scan cyclic voltammetry in the NAcc of awake rats. Phillips et al. (2003) reported that phasic increases in NAcc dopamine concentration were time-locked to cocaine-predicting cues, and only in animals that had already experienced the cue-cocaine pairing. These cue-evoked changes in dopamine concentration are abolished if VTA is inactivated (Sombers et al., 2009), supporting the implication that these concentration transients were the result of simultaneous burst firing of dopaminergic neurons. Moreover, Day et al. (2007) showed that, in a classical conditioning task, such phasic dopamine changes occur time-locked to reward early in training, but move to the reward predicting cue with further training, consistent with the changes in dopaminergic neuron firing reported by Schultz and others (Schultz et al., 1997; Waelti et al., 2001).

The second issue is that, even if the phasic burst of spikes elicits a phasic change in dopamine concentration, there is a substantial explanatory gap between the change in concentration and the change in value and probability of action selection required by the theory (Pennartz, 1995). That is, both dopamine's transmission dynamics (release, re-uptake, and spread to extra-synaptic sites) and consequent modulation of synaptic plasticity are assumed to be the mechanism that changes the representation of value, and hence the probability of selecting an action (Reynolds and Wickens, 2002; Montague et al., 2004a). As section 4 made clear, there is a long and treacherous path between the presence of dopamine and the effects it has on a neuron.

### 5.5.2. Different theories for different roles in separate regions of striatum?

One parsimonious explanation is that phasic dopamine subserves different roles in different areas of striatum. One problem with this explanation is that, at least in simple classical and in-

strumental conditioning tasks, the same responses in dopamine cells can be found throughout SNc and VTA, thus providing the same afferent firing pattern to all areas of striatum (Kiyatkin, 2002). However, numerous mechanisms can be postulated that would result in varying dopamine concentration across the striatum. Different ratios of GABAergic and cholinergic input to each dopaminergic region projecting to the striatum would recruit different numbers of phasically-firing neurons in those regions (Floresco et al., 2003). Even if the firing patterns are the same, the gradient of dopamine transporter across the dorsal-ventral axis of the striatum could translate into different profiles of dopamine concentration across the dorsolateral, dorsomedial, and ventral striatum (Cragg and Rice, 2004; Wickens et al., 2007). Finally, there is evidence that separate populations of dopaminergic VTA neurons project to the prefrontal cortex, amygdala, and NAcc, and these separate populations may differ in their receptor expression and ion channels (Carr and Sesack, 2000; Margolis et al., 2008). Indeed, Roeper and colleagues (Lammel et al., 2008) have recently described a double separation of hindbrain dopaminergic neuron populations: they reported a fast-firing, low dopamine-transporter expressing, dopaminergic neuron sub-population, in addition to the conventional, slow-firing, dopaminergic neurons. These populations have separate targets: the slow-firing dopaminergic neurons were retrogradely labelled by injections in lateral shell and DLS, the fast-firing population were retrogradely labelled by injections in medial shell, core, medial prefrontal cortex, and basolateral amygdala. Moreover, within the fast-spiking population, the sub-population projecting to the medial prefrontal cortex uniquely lacked D2 autoreceptors. Hence, not all phasically firing VTA neurons may project to the NAcc.

There is certainly good evidence that tonic dopamine concentrations in shell and core significantly differ in many behavioural tasks (Bassareo and Chiara, 1999; Bassareo et al., 2002; Cheng and Feenstra, 2006). Localised striatal studies of the incentive salience hypothesis have focused on the nucleus accumbens, with authors proposing both medial shell (Kelley, 1999) and core (Cardinal et al., 2003) as its locus. The studies of core/shell differences in dopamine concentration do not find a clear cut distinction in that tonic dopamine concentration in both areas increases as function of general motivation (Bassareo and Chiara, 1999), but tonic dopamine concentration in the shell alone is sensitive to novelty (Bassareo et al., 2002). Perhaps one problem here comes from a mix up of definitions: incentive salience is the attribution of ‘wanting’ to rewarding stimuli, whereas motivation, more generally, usually refers to the initial level of response to a stimulus or task. A further problem is that these studies can only address the tonic level of dopamine, whereas the theories detailed above are all concerned with phasic changes in dopamine. The data then do not currently address the simultaneous implementation of different roles for dopamine in different areas of striatum.

### 5.5.3. *Compatible computational theories of phasic dopamine?*

Another parsimonious explanation is that all three theories contain an element of truth, and actually address different as-

pects of the same underlying functional role. The concept of ‘incentive salience’ — increased working for a valued reward — is difficult to dissociate from the biased probability of action selection of the reinforcement learning interpretations of phasic dopamine (McClure et al., 2003) and from the ‘biased repetition’ of the action-outcome learning theory. They all place the phasic dopamine signal as the cause of increased repetition of a behaviour. The principal distinction is that to work as incentive salience or reward prediction error, an outcome must have a known rewarding value; whereas the biased repetition occurs with outcomes of unknown (but not aversive) value. We suggest that they address two overlapping stages of a causal chain: the phasic dopamine causing biased repetition establishes the action-outcome pairing; the continued phasic dopamine signal makes sure the action perseveres if it is associated with a currently required rewarding outcome. It does not then follow that phasic dopamine must be a reward prediction error signal (Redgrave et al., 1999b; Redgrave and Gurney, 2006). Nonetheless, as reviewed above, there is increasing evidence of the correlation of dopaminergic neuron activity (Bayer et al., 2007; Roesch et al., 2007) and dopamine concentration (Day et al., 2007; Sombers et al., 2009) with reward value and prediction error, and for the use of reward prediction error information within the striatum: neural activity in primate dorsal striatum can correlate with reward outcome (Lau and Glimcher, 2007) and reflect learnt action-outcome probabilities (Samejima et al., 2005).

### 5.5.4. *Computational roles of tonic dopamine*

The computational role of tonic dopamine has received comparatively little attention. As noted above, tonic dopamine concentration can vary across striatal regions and over time. Indeed, the dopamine-dependent motor symptoms of Parkinson’s disease are ascribed to the chronic loss of tonic, rather than phasic, dopamine (Zigmond and Burke, 2002). In keeping with this view, one proposal for tonic dopamine’s role is as a controller for the frequency and ease of switching behaviours (Redgrave et al., 1999a). Computational models of the basal ganglia have shown how behaviour selection and switching can breakdown at either extreme of simulated tonic dopamine (Gurney et al., 2001b; Humphries et al., 2006): the loss of tonic dopamine leads to an inability to select actions, consistent with the akinesia of Parkinson’s disease; an excess of tonic dopamine leads to an inability to de-select the current behaviour, consistent with the behavioral stereotypies expressed by rats after systemic or intrastriatal injections of the dopamine re-uptake blocker amphetamine or intrastriatal injections of nonselective dopamine agonists (Humphries et al., 2006).

Niv and colleagues have suggested a different computational model for tonic dopamine, which nonetheless predicts it has a role in switching actions (Niv et al., 2006). They presented a reinforcement learning model of free operant responding that showed how average reward rate could drive response vigour, such as the rate of lever pressing. As changes in tonic dopamine are strongly connected with similar changes in response vigour (Salamone et al., 2007), they posited that tonic dopamine might be a read-out of the average reward rate. They also noted that

a consequence of reducing the average reward rate was to reduce switching away from the currently chosen action, again implicating tonic dopamine in action selection.

The control of tonic spiking in the VTA and the corresponding actions of tonic dopamine within the NAcc are partially understood. The proportion of tonically firing VTA neurons appears to set the tonic concentration of dopamine (Floresco et al., 2003; Venton et al., 2003), and this depends on the level of inhibition from VP (Floresco et al., 2003). By contrast, the number of bursting cells in VTA appears to set the phasic release concentration of dopamine, and depends on the activity of the PPN (Floresco et al., 2003). The concentration of tonic dopamine in turn acts via striatal D2 receptors to set the relative level of prefrontal cortex input to the MSNs (Goto and Grace, 2005): increasing D2 activation reduces prefrontal input, and vice-versa, consistent with the general action of D2 receptors in the striatum (section 4.3). In behavioural tasks, increasing D2 activation in the NAcc decreased the ability of rats to switch behavioural strategy (Goto and Grace, 2005). From these results, Goto et al. (2007) proposed that the dip in dopamine firing following reward omission causes an interruption of tonic dopamine release, and hence would increase prefrontal cortex influence over NAcc MSNs, allowing the switch away from an unrewarding strategy to take place. This is commensurate with the above general proposals for tonic dopamine's control over switching and selection by the basal ganglia.

#### 5.5.5. Dopamine and spatial navigation

Little work has specifically addressed the possible roles of striatal dopamine in spatial navigation. Whishaw and Dunnett (1985) performed a comprehensive battery of tests comparing intact and nigro-striatal bundle lesioned rats on both distal- and local-cue versions of the Morris water maze task. They found that bilaterally lesioned rats could not learn to successfully navigate to the platform in either version of the task; moreover, rats receiving bilateral lesions after learning showed severe retention deficits when re-tested in either version of the task. They also established that the lesioned rats could perform all the motor actions necessary to swim to and scale the platform, and so their results did not reflect an inability to complete the task. Mura and Feldon (2003) replicated the tests of post-lesion retention on the Morris water maze, and found essentially the same results for bilaterally lesioned rats. Both sets of authors conclude that their findings are compatible with a role for dopamine in switching between appropriate behavioural strategies that have already been acquired: the behaviour of the lesioned rats suggested that they were unable to express the correct strategy for the task (Whishaw and Dunnett, 1985; Mura and Feldon, 2003). The results of Whishaw and Dunnett (1985) also clearly point to a role in learning routes, whether place or cue-guided, for striatal dopamine.

## 6. Behavioural roles of the ventral striatum

How then are all these inputs combined to shape behaviour? We briefly review here insight from behavioural assays follow-

ing lesion, inactivation or chemical manipulation of NAcc subregions, and from NAcc neural activity correlates of behaviour.

### 6.1. Behavioural consequences of ventral striatal manipulations

Ikemoto (2007) points out that many techniques (microdialysis, iontophoretic, and so on) used to study shell and core distinctions are hampered by the technical difficulty of distinguishing the thin lateral shell from the overlying core. For example, iontophoretically-applied NMDA agonist into the lateral shell would inevitably diffuse dorsally into a substantial region of the core. Ikemoto (2007) suggests that we should interpret most, if not all, such studies as actually comparing medial shell with a combined core and lateral shell region. This, in turn, nicely maps onto the dopaminergic neuron connections of these two regions, shown in Figure 2b, with the medial shell reciprocally connected with medial VTA and the core and lateral shell together reciprocally connected with lateral VTA.

A classic effect of manipulating nucleus accumbens is a change in spontaneous locomotion (see Pennartz et al., 1994, for a thorough review). Injections of dopamine, amphetamine, and agonists for NMDA or AMPA into the accumbens all cause hyperlocomotion in rats. Activating primary afferent structures has opposing effects. NMDA agonist injection into ventral subiculum also induces hyperlocomotion, but the same injection into basolateral amygdala reduces locomotion from baseline levels. The projections from both these structures are excitatory (Mulder et al., 1998) so, assuming that the agonist activated NAcc-projecting neurons in both these structures, these differences are not simply due to opposite effects on NAcc neurons.

Afferent lesion and receptor blocking studies provide the strongest evidence for spatial navigation roles of the ventral striatum. Blocking NMDA receptors in the core, which putatively prevents synaptic plasticity, degrades performance on many spatial tasks: rats cannot learn paths to rewards (Kelley, 1999), learn spatial sequences (in this case, of lever presses) to achieve reward (Bauter et al., 2003), or locate a hidden platform in a Morris water maze when encoded by distal cues alone (Sargolini et al., 2003). In addition, local injections of dopamine antagonist (Ploeger et al., 1994) or immediate post-training D2 antagonists (Setlow and McGaugh, 1998) into NAcc impaired rats' abilities to express behaviour based on knowledge of self-location. These results are also consistent with the learning deficits of dopamine-depleted rats (Whishaw and Dunnett, 1985) discussed above, as dopamine is also thought to be essential for synaptic plasticity within striatum.

Lesioning hippocampal afferents to NAcc by cutting the fornix/fimbria pathway results in numerous spatial navigation problems. Whishaw and colleagues have shown that rats with such lesions have intact place responses, but great difficulty in constructing paths to them (Whishaw et al., 1995; Gorny et al., 2002). In a Morris water maze, lesioned rats can swim to a pre-lesion submerged platform location, but not a new one (Whishaw et al., 1995); in open-field exploration, lesioned rats do not show path integration trips to their homebase (Gorny et al., 2002). Data from these studies has to be interpreted with

care <sup>6</sup>, but are consistent with the NMDA blockade studies. Therefore, we conclude that the three lines of research — on dopamine, NMDA blockade, and fornix/fimbria lesion — all point to a key role for NAcc core in acquiring routes in place-based tasks.

By contrast, rats with lesions of the shell have shown no deficits in spatial tasks (Kelley, 1999; Kelley et al., 2005), a surprising result given the considerable input from hippocampal formation that the shell receives (see section 5.1.1). Albertin et al. (2000) showed that a lesion of the medial shell prevented rats from associating reward magnitude with a particular location, but did not prevent the rats from correctly following the cued sequence of reward location visits or being motivated to consume water. A long series of studies by Kelley and colleagues has instead shown that the manipulations of the shell alter free-feeding behaviour, including locomotive approach (Kelley et al., 2005). Rats with either AMPA antagonist (blocking excitatory synapses) or GABA agonist (stimulating inhibitory synapses) injections in the shell eat voraciously, but do not work harder for that food. Whereas increasing dopamine in the shell by amphetamine injection causes rats to work harder for food – for example, achieving a higher break point of lever presses on a progressive ratio schedule – but not to consume more once obtained (see Figure 7 of Kelley et al., 2005). Given the arguments of (Ikemoto, 2007) discussed above, we conclude that all these effects were obtained mostly from the medial shell. This conclusion receives considerable support from studies showing that the induced voracious eating is prevented by deactivating lateral hypothalamus with a concurrent GABA agonist injection (Kelley, 1999), and medial shell is the principle basal ganglia afferent of lateral hypothalamus. This research suggests that removing medial shell inhibition of lateral hypothalamus is necessary to initiate free-feeding.

Some authors have argued that the nucleus accumbens plays no role in goal-directed instrumental conditioning (Cardinal et al., 2003). In an excellent review, Nicola (2007) showed that there was a clear dissociation in the type of instrumental tasks: dopamine within the nucleus accumbens was necessary for successful responses on any task with long intervals between stimuli. From this evidence, Nicola (2007) proposed that accumbal dopamine is necessary to switch away from any ongoing action to the required response of the instrumental task. We note that this could also be consistent with our hypothesis of hippocampus as a memory for temporal events: rather than switching to a required action, the intact dopamine system may be necessary for learning when the response is required, acting on hippocampal output to NAcc carrying temporal event information.

## 6.2. Behavioural correlates of ventral striatal activity

Numerous studies have reported spatially modulated firing in the ventral striatum, but few examples of genuine place fields

---

<sup>6</sup>As noted in section 5.1.1, the fornix/fimbria bundle conveys subiculum and CA1 inputs to NAcc, but not projections from entorhinal cortex (Totterdell and Meredith, 1997); however, it contains other fibres, both from hippocampal formation to other targets, and from other subcortical inputs to the hippocampal formation (Witter and Amaral, 2004).

(e.g. Shibata et al., 2001; Mizumori et al., 2004; Mulder et al., 2004; Pennartz et al., 2004; Taha et al., 2007). The studies of Shibata et al. (2001) and Mulder et al. (2004) showed many putative MSNs whose activity was a conjunction of correlations with specific parts of a plus-maze task and of specific positions within the maze; for example, one class of MSNs increased their activity relative to the arrival at the end of a specific rewarded arm, and not when arriving at the end of other rewarded arms. In addition, Mulder et al. (2004) report neuron classes whose activity correlated with segments of a route on the maze; for example, some MSNs fired only when approaching the centre of the maze along an arm. Shibata et al. (2001) also report that some cells change their positional correlations when the task changes, even though the hippocampal place fields were known to not re-map (Trullier et al., 1999).

All these spatial navigation studies found NAcc MSNs whose activity only or conjointly correlated with direction of motion. For example, Taha et al. (2007) distinguished two classes of putative MSNs, one class having correlates with direction of movement, the other having correlates with a delay period in the task. In the latter class were a subset of cells that increased their activity during the period where the rat was required not to move, suggesting an active ‘no go’ signal, and consistent with the proposed role for NAcc in timing behaviour (Nicola, 2007). We also contend that the cells showing a decrease of activity within the same period and during movement were consistent with signalling the selection of free-feeding by disinhibition of the lateral hypothalamus, following the model proposed by Kelley (1999) that we discussed above.

Others have reported similar direction correlations, even in tasks that did not have an explicit locomotion component. For example, rats self-administering cocaine hyperlocomote between lever presses, and phasic increases of NAcc MSN activity in these periods correlate with the direction of locomotion (Peoples et al., 1998). These phasic changes are imposed on, and independent of, a slowly recovering dip in tonic MSN activity after each cocaine infusion, whose time-course matches the predicted changes in dopamine concentration following the infusion (Peoples et al., 1998). Other cocaine self-administration studies report phasic changes in NAcc MSN activity before the lever press that correlate with elements of orienting to the lever, such as turning and head raising (Chang et al., 2000). Correlates to two or three elements were often recorded in the same animal, suggesting an encoding of the behavioural sequence across the MSNs (Chang et al., 2000).

Many electrophysiological studies of NAcc activity correlates report MSNs that change their activity just before, or during, the delivery of reward (e.g. Shibata et al., 2001; Mizumori et al., 2004; van der Meer and Redish, 2009). Though often referred to as “reward anticipatory” or “reward-responsive” cells, it is difficult to rule out their activity as simply encoding the pause in locomotion or other motor behaviour required for taking and consuming the reward. Nonetheless, there is evidence that NAcc MSN activity encodes aspects of reward (Setlow et al., 2003; Khamassi et al., 2008). A particularly convincing demonstration by Setlow et al. (2003) tested rats on a go/no-go odour task, in which one odour predicted reward delivery and

the other an aversive stimulus. Early in training, one population of MSNs appeared whose firing after odour presentation correlated with the outcome, but did not correlate with success on the task. Later, a second population of MSNs appeared whose firing correlated with both one odour cue and with success on task. Moreover, if the cue-outcome pairing was reversed, then early-responsive MSNs re-mapped to the other odour cue, but the late-responsive MSNs did not. Thus, this is consistent with the early-responsive population encoding the value or valence of the predicted outcome, and the late-responsive population encoding the motor action required – go/no-go – for each cue. Interestingly, encoding of the odour cue predicting the aversive stimulus strongly dominated in both populations.

Striatal interneurons, and not just the MSNs, show activity changes that correlate with specific task or behavioural events. Particularly striking is the reward-related encoding by the tonically-active neurons – putatively the cholinergic interneurons – of the primate: their activity consistently pauses at the time of reward-related events, at the occurrence of both a reward-predicting stimulus and the reward itself (Apicella et al., 1991; Aosaki et al., 1994; Cragg, 2006). Reward-related changes in the activity of tonically-firing neurons has also been reported from the dorsal striatum (Schmitzer-Torbert and Redish, 2008) and NAcc (Mulder et al., 2005; Khamassi et al., 2008) of rats performing spatial navigation tasks. Mulder et al. (2005) reported tonically-firing neurons whose activity changes differentiated between reward boxes; Khamassi et al. (2008) reported tonically-firing neurons whose pauses lasted as long as the time it took to deliver the reward. These studies from both primate and rat have led to the current hypothesis that pauses of tonically-active neurons allows dopamine to maximally affect striatal MSNs and plasticity at their synapses: the dip in acetylcholine during these pauses could enhance the amount of dopamine released for a given burst of dopaminergic neuron spikes (Cragg, 2006).

Some progress has been made on picking apart the contributions that afferent inputs to ventral striatum make to its behavioural correlates. Pennartz et al. (2004) showed that ventral striatal neuron ensembles replay activity patterns during slow-wave sleep after a maze task, just like hippocampal formation neurons (Wilson and McNaughton, 1994). The replays occurred during hippocampal EEG ripples<sup>7</sup>, suggesting the reactivation is functionally linked to hippocampal activity. Recently, Gruber et al. (2009a) demonstrated selective functional links between the NAcc core and its afferents in awake rats. During free exploration of a test chamber, local-field potentials in ventral hippocampal formation, prefrontal cortex, NAcc core and shell were all coherent in the theta-band (~ 7 Hz). When subsequently engaged in lever-pressing, local field potentials in the prefrontal cortex and NAcc core became coherent in the delta-band (1-4 Hz), while hippocampal formation and NAcc shell remained coherent in the theta-band. These results are consistent with the direct hippocampal formation projections dominating the activity of the shell, while the core is dominated by its inputs from prefrontal cortex.

Nicola and colleagues have dissected the contributions of VTA, medial prefrontal cortex, and basolateral amygdala to single ventral striatal neuron activity correlates on a discriminative learning task (Yun et al., 2004; Ishikawa et al., 2008; Ambroggi et al., 2008). Rats were trained to respond (either nose-poke or lever press) during one of two tones to receive reward. Most ventral striatum neurons responding to the onset of the reward-associated tone increased their activity. These responses were abolished by inactivating either the VTA (Yun et al., 2004), medial prefrontal cortex (Ishikawa et al., 2008), or basolateral amygdala (Ambroggi et al., 2008) with GABA agonists. In all cases, abolishing the striatal responses corresponded to a large fall-off in correct performance on the task. Together these results suggest that correct responding to a predictive stimulus requires the integration of signals from these three regions by the ventral striatum.

## 7. Convergence of inputs: channels within the basal ganglia

What substrate underpins the computations of the basal ganglia, using the combinations of the afferent information, and giving rise to the correlates of ventral striatal activity? A central concept governing the organization of basal ganglia connectivity is the existence of parallel anatomical loops — channels — running throughout the basal ganglia nuclei (Alexander et al., 1986; Middleton and Strick, 2000). A distinction can be made between macroscopic and microscopic channels.

### 7.1. Macroscopic channels

At the broadest scale, three macroscopic channels are formed by the parallel dorsolateral, dorsomedial, and ventral basal ganglia domains, as each has a unique set of closed return pathways defined by the thalamo-cortical loop that the domain is embedded in (Figure 1a). In a closely related scheme, Alexander et al. (1986) originated the channel idea in the primate by identifying five closed send-and-return loops running in parallel, each originating from an identified cortical area, passing through the basal ganglia, and returning to the originating cortical area via thalamus. (These loops are also open in the sense that projections from different, but related, cortical areas converge on the same locations in striatum (Romanelli et al., 2005)). Recent trans-neuronal tracing data is consistent with at least ten such channels within the basal ganglia output nuclei (Middleton and Strick, 2000), though it is not clear to what extent they are sustained within the basal ganglia intrinsic circuitry. Detailed anatomical reconstructions of the SNr have separately established the existence of numerous discrete channels within it, corresponding to the termination zones of its striatal afferents, and the output targets of those zones (Deniau and Chevalier, 1992; Deniau et al., 1996).

The core- and shell-based basal ganglia circuits form separate macroscopic channels. Their respective outputs from dorsomedial SNr and VP predominantly target the ventromedial and mediodorsal thalamus, which terminate in different layers and partially overlapping areas of the medial prefrontal cortex (Groenewegen et al., 1999a). Thus, both have complete cortico-basal ganglia-thalamo-cortical loops.

<sup>7</sup>Brief high-frequency oscillations imposed on the slow-wave.

### 7.2. Microscopic channels

Microscopic channels are discrete parallel loops running *within* a macroscopic channel. For example, the somatotopic map found within the dorsal striatal motor territory is maintained throughout the basal ganglia intrinsic circuitry, such that there are separate channels for arm, leg, and face representations (Alexander and Crutcher, 1990; Romanelli et al., 2005). Similar topographic maps have been proposed for the other macroscopic channels (Alexander and Crutcher, 1990). Moreover, within these limb representations there may be further discrete channels corresponding to particular movements, demonstrated in striatum by micro-stimulation (Alexander and DeLong, 1985) and markers for metabolic activity during behavior (Brown and Sharp, 1995a), and/or to detailed body map locations (Brown et al., 1998).

Existing computational models, primarily concerned with dorsal striatum and its associated circuits, use such microscopic channels, each channel representing a different putative action (Redgrave et al., 1999a; Gurney et al., 2001a; Humphries et al., 2006) or behaviour (Khamassi et al., 2005; Prescott et al., 2006). Anatomically, the channels in striatum and STN are defined by the converging input from topographically-related representations in cortex, and the channels in GP and the output nuclei by their corresponding striatal afferents. There is considerable evidence for extending the concept of these channels to the ventral striatum and its associated circuits.

### 7.3. Enumerating channels within the ventral basal ganglia

Pennartz et al. (1994) and Groenewegen et al. (1999c) have argued for the existence of discrete neuron clusters in the NAcc shell, corresponding particularly to the fragmented amygdala input (see Figure 3). We note two possible analogous features for these clusters in the rest of striatum. First, that the fragmented amygdala projections to core specifically target the ‘patch’, and thus the amygdala-targeted neuron clusters in the shell may form an equivalent to the ‘patch’ — despite a lack of differentiating staining — from which MSNs project predominantly to the dopaminergic neuron bands. Second, the size of these neuron clusters is comparable to the micro-stimulation zones of dorsolateral striatum mentioned above, and could form neuron groups with specific behavioural correlates. They may of course not be equivalent to either of these, but nonetheless provide precedent for a channel architecture.

We can expand on (Pennartz et al., 1994; Groenewegen et al., 1999c) by enumerating all the possible ventral basal ganglia channels defined by unique sets of inputs from hippocampal formation, amygdala, and prefrontal cortex regions. If we separately distinguish ‘patch’ and ‘matrix’ targeted projections then around 40 neuron groups are defined by unique combinations of the inputs shown in Figure 3. Many of these neuron groups share a common input in a given region, and the unique combinations are created by the topographically non-overlapping sets of additional inputs to that region. For example, in caudal ventromedial shell, all cells are in the zone that receives input from the intermediate subiculum, and subsets of these are in zones that also receive input from: infralimbic cortex; prelimbic cortex; infralimbic cortex and rostral accessory basal amygdala;

prelimbic cortex and rostral accessory basal amygdala; and so on.

We do not of course know that these anatomically defined inputs correspond to functionally meaningful units — these broad regional projections may further subdivide into populations — but such an enumeration provides some insight into the basic capacity for representing unique combinations of information within the ventral basal ganglia. For if each of the 40 groups does indeed provide a substrate for the integration of a unique combination of information, then it is little wonder that recordings in the ventral striatum have revealed such a broad array of behavioural correlations with neuron activity. An excellent example is the population of MSNs, discussed above (section 6.2), that phasically respond after the onset of a reward-predicting tone: the loss of this response after the inactivation of either medial prefrontal cortex or basolateral amygdala suggests that these anatomical overlaps are also functional confluences of these inputs.

The existence of functional channels running through the ventral basal ganglia is nicely illustrated by attempts to dissect how locomotion is changed by NAcc manipulation. A long-running theory is that hyperlocomotion resulting from NAcc activation occurs via the NAcc-VP-PPn pathway (Pennartz et al., 1994; Grillner et al., 1997). The PPn is considered part of the mesencephalic locomotor region, a group of structures whose stimulation reliably causes hindlimb stepping (Whelan, 1996). In this theory, hyperlocomotion arises through disinhibition: increasing the activity of NAcc MSNs inhibits VP neurons, which, in turn, reduces their inhibition of the PPn. This disinhibition of PPn increases the activity of its neurons and, hence, causes increased locomotion. Direct tests of this theory have proven otherwise. Lesions of the PPn (Swerdlow and Koob, 1987; Inglis et al., 1994) or adjacent structures in the mesencephalic locomotor regions (Allen et al., 1996) do not alter hyperlocomotion induced by injections into the NAcc.

Nonetheless, VP is involved in hyperlocomotion, and sits within at least two distinct locomotion channels. Injection of either mu-opioid or AMPA agonists into VP causes hyperlocomotion (Kalivas et al., 2001). Only the mu-opioid effect is blocked by GABA<sub>B</sub> agonist injected into MD thalamus (Kalivas et al., 2001), consistent with other studies showing that hyperlocomotion induced from the NAcc could be blocked by this lesion (Swerdlow and Koob, 1987). Thus, at least two channels are implicated in locomotion: an NAcc-VP-MD thalamic channel, and a second, AMPA-sensitive, channel involving VP. Though speculative, this second channel may be mediating locomotion via the pallidal projections to lateral hypothalamus and lateral preoptic areas, whose stimulation reliably elicits stepping (Sinnamoni, 1993). Finally, the opposing effects of hippocampal formation and amygdala afferent stimulation on hyperlocomotion, noted above, are also consistent with a subset of their projections targeting separate channels in the NAcc.

The VP projection to MD thalamus has also been implicated in working memory, as part of the complete cortico-basal ganglia-thalamo-cortical loop made up of prefrontal cortex-NAcc-VP-MD thalamus-prefrontal cortex projections. For example, AMPA or mu-opioid agonists injected into VP degraded

rats' performance only on the delayed version of an alternating-arm T-maze task, where the previously run arm had to be maintained in memory, but not an undelayed version (Kalivas et al., 2001). Performance was restored near to normal levels by concurrent injection of a GABA<sub>B</sub> antagonist into MD thalamus, suggesting that activation of VP led to excessive inhibition of MD thalamus, preventing the maintenance of working memory items in this prefrontal cortex based loop. Inactivating MD thalamus bilaterally, or prefrontal cortex and NAcc contralaterally, disrupts rat's performance on delayed radial-arm maze tasks, not random foraging in the same maze (Floresco et al., 1997, 1999). Thus, the complete loop seems necessary for working memory, at least of spatial tasks.

The presence of discrete microscopic channels in the ventral striatum is separately supported by recent work from Gruber et al. (2009b) showing that burst-like stimulation of mPFC applied to adjacent locations separately inhibits or enhances firing of the same MSN, and that the inhibition is consistent with feed-forward input from mPFC-driven FSIs.

#### 7.4. Evidence for convergence of inputs at single cells in ventral striatum

Reinforcing the channel concept, overlap of inputs from the hippocampal formation, prefrontal cortex, and amygdala has also been demonstrated at the single neuron level. Anatomically, individual cells in the NAcc receive monosynaptic input from both ventral subiculum and prefrontal cortex (French and Totterdell, 2002). Stimulation studies provide a broader picture. Excitatory post-synaptic potentials have been observed in the same NAcc neuron following individual stimulation of prelimbic/infralimbic cortex and fornix/fimbria (carrying hippocampal formation fibres to NAcc) (O'Donnell and Grace, 1995), of basolateral amygdala and fornix/fimbria (Mulder et al., 1998; Floresco et al., 2001a), and — in a handful of cases — all three (O'Donnell and Grace, 1995; Finch, 1996; Goto and O'Donnell, 2002). The localisation of these cells has rarely been reported, but where it has been established (Mulder et al., 1998) it is consistent with the anatomical data in Figure 3. Note that the majority of the cells reported in these studies are probably MSNs, but some convergence at single inter-neurons also occurs.

These stimulation studies have also shown that the order of activity arriving at the NAcc neuron's dendrite is critical. Under anaesthesia, stimulation of either hippocampal formation (fornix/fimbria), basolateral amygdala or paraventricular thalamus has an enhancing effect on a NAcc neuron's response to subsequent prefrontal cortex stimulation, by either eliciting or maintaining a depolarised membrane potential (O'Donnell and Grace, 1995; Goto and O'Donnell, 2002; McGinty and Grace, 2009b). The magnitude of the enhancement may be inversely correlated to the strength of the prefrontal cortex stimulation (McGinty and Grace, 2009b) — the weaker the prefrontal cortex input, the greater the enhancement of response. If the order of stimulation is reversed, then a suppressing effect is observed, as a reduction in the second excitatory post-synaptic potential (Goto and O'Donnell, 2002). Similarly, if stimulation of hippocampal formation (fornix/fimbria) precedes that of basolat-

eral amygdala, then an enhancement of response is observed; if the order is reversed, a suppression of response is observed (Mulder et al., 1998). Effects of stimulation intensity interact with the timing of inputs. Pulse train stimulation of basolateral amygdala depresses the response to subsequent prefrontal cortex stimulation, rather than enhancing it (McGinty and Grace, 2009a). Thus, each source of glutamatergic input to individual MSNs seems to gate responses to the other glutamatergic inputs, rather than simply summing. Both local circuit interactions and ordering of synapses on dendritic trees have been evoked as explanations for this gating (Groenewegen et al., 1999b; Goto and O'Donnell, 2002); clearly this is fertile ground for future computational modelling work.

Gating is not always required or observed. Initial reports suggested that prefrontal cortex stimulation only initiated a response if preceded by stimulation of another NAcc afferent (O'Donnell and Grace, 1995), but recent work has shown that short trains of prefrontal cortex stimulation alone can elicit a prolonged depolarisation of MSNs (Gruber and O'Donnell, 2009; Gruber et al., 2009a,b). In awake rats, stimulation of hippocampal formation inputs before stimulation of prefrontal cortex did not enhance the response of an individual MSN or the firing rate of the recorded MSN population (Wolf et al., 2009). Instead, the individual responses were not significantly larger than the response to prefrontal cortex stimulation alone, pointing to sublinear summation of afferent excitatory input. These results suggest that anaesthetic has a large role to play in the gating effects. They also further illustrate the caution required when interpreting studies of the striatum under anaesthetics (Mahon et al., 2001), because of the strongly entraining effects of globally coherent cortical activity on the striatal neurons.

## 8. A roadmap for quantitative models of ventral basal ganglia

We bring together the above work on the functional architecture, input distribution, functions of afferent domains, and correlates of NAcc manipulations and activity into a roadmap for developing a more complete understanding of the ventral basal ganglia.

### 8.1. A theory and model of the NAcc core sub-circuit

Much of this paper has drawn explicit parallels between the dorsal domains and the core-based part of the ventral domain of the basal ganglia. The core and dorsal striatum have corresponding MSN projections, interneurons, and post-synaptic dopamine receptor distributions. We also noted that both cortical and intralaminar thalamic inputs to NAcc core also send inputs to STN, and that STN does not receive input from any other NAcc afferent structures. This input pattern fits nicely with the STN's putative position within only the core-based part of the functional anatomy, and is identical to the structure of its inputs in the dorsal basal ganglia.

We drew these parallels to support our first hypothesis of ventral basal ganglia function: the core-based circuit is a selection mechanism that operates in the same way as the dorsal

domains. Briefly, this implies that we expect activity in each channel to represent the salience of the elements – be they motor programs, strategies, goals – competing for selection, that the competition for selection is based on the relative saliences, and that the resolution of competition relies on the overlapping STN and striatal inputs to SNr (Redgrave et al., 1999a; Gurney et al., 2001a; Humphries et al., 2006). The full channel-based selection architecture of the basal ganglia is illustrated in Figure 6.

Nicola (2007) has separately proposed that this portion of the NAcc and associated basal ganglia nuclei perform action selection — we have considerably extended that proposal here with a detailed breakdown of the underlying anatomy, parallels with the dorsal domains, and collation of evidence for the inputs to this system. Interestingly, we find ourselves in broad agreement with Nicola (2007) that NAcc core encodes locomotion among its primary actions, and that dopamine plays a key role in facilitating selection.

### 8.1.1. *Multiple selection circuits originating in the core*

To complete the hypothesis, we must define the elements that are being selected. If we consider its array of functional roles along with the input anatomy (Figure 3) it immediately becomes clear that there is a disparity between the spatially-correlated activity in NAcc core, and its lack of inputs from the place fields in CA1/CA3. The few authors who have discussed NAcc’s functional role in spatial navigation (e.g. Brown and Sharp, 1995b; Redish and Touretzky, 1997; Arleo and Gerstner, 2000; Chavarriga et al., 2005) typically consider the NAcc as a selector for direction of movement; routes are then built by associating a sequence of place-neuron firings with appropriate directions of movement that ultimately reach a rewarded location. These associations are encoded in the synaptic weights of direct projections from place cells in CA1/CA3 to NAcc MSNs (Brown and Sharp, 1995b; Arleo and Gerstner, 2000; Chavarriga et al., 2005). We can see that this cannot literally be true for the core because of its input structure. Nonetheless, the behavioural correlates of core MSN activity do support a coding scheme for direction of movement.

The lesion and recording studies that establish the behavioural correlates address a very broad area of the core, but our discussions of the channel architecture identified how specific the inputs to regions of the core are. We suggest that the rostral-medial core sub-circuit is the basis for selection of direction modulated by the estimated likelihood of reaching the spatial goal from the current location (which we posit is the spatial navigation equivalent to action-outcome contingency in instrumental conditioning). Likelihood estimation is proposed to originate from the prelimbic cortex (section 5.2). Current location could be determined directly by the MSNs. Deep layer medial entorhinal cortex (layer V) is the source of projections to the medial core, so presumably the grid/head direction combination cells found there form part of that input. Hence, by an analogous method to that proposed for place neuron derivation from grid cells (section 5.1), it could be that spatial modulation observed in the core is due to convergent inputs from deep layer grid cells to MSNs.

Analogously, we suggest that the caudo-lateral core sub-circuit is the basis for selection of direction modulated by the value of previous outcomes of choosing that direction (input from orbitofrontal cortex — see section 5.2) from the current location. Unfortunately the origin of spatially-modulated activity in the lateral core remains a mystery, as its dominant hippocampal formation input originates from deep layers of lateral entorhinal cortex, and coding in this area is poorly understood (Knierim, 2006). One possibility is that spatially-modulated activity here is due to lateral entorhinal cortex firing to configurations of landmarks visible from that position.

The functions of the other regions of the core are harder to discern. Caudo-medial core appears to receive no spatial information, at least none related to the hippocampal formation; nonetheless it receives prelimbic cortical input, and we tentatively propose that its sub-circuit is selecting for spatial goals to prioritise, and this may be reflected in the neural correlates of strategy shifts within NAcc (Shibata et al., 2001) and in prelimbic cortex (Battaglia et al., 2006b; Wiener et al., 2007). Rostro-lateral core’s role is particularly unclear: as well as the poorly understood input from lateral entorhinal cortex, its main cortical input is from the very recently delineated rat homologue of the primate dorsolateral prefrontal cortex (Uylings et al., 2003). With no studies of behavioural correlates of neural activity in spatial tasks that we are aware of, rostro-lateral core’s function must remain an open question.

However the direction competition is resolved, our hypothesis for directional coding and selection implies that for open-field navigation the NAcc core is necessary to learn the route to a rewarding location (where ‘rewarding’ here is in the broad sense of having some value to the animal — a platform in a Morris water maze may be ‘rewarding’ as it enables the animal to escape from the water). This is consistent with lesion and neurochemical studies we reviewed above in sections 5.5 and 6.1, and suggests that the hypothesis may be further tested in a similar manner: for example, inactivation of the core would produce deficits in recalling a previously learnt route to an open-field location.

Finally, we address the role of the ‘patches’ in core. We assume that ‘patch’ MSNs in the lateral and medial core receive the same input as their ‘matrix’ counterparts, outlined above, enhanced by amygdala input representing the presence of any current stimulus with an associated valent outcome. The ‘patch’ projection is inhibitory to dopamine cells in the SNc and VTA1, and we propose that its role is to increase the baseline inhibition that an unexpected event must overcome to elicit a phasic dopamine pulse. In this way, ‘patch’ output prevents a phasic dopamine response to a known stimulus value (by amygdala input) or known outcome, and therefore avoids relearning a known action-outcome pair.

The implications of all this for future computational models are twofold. First, combined hippocampal formation and basal ganglia models rightly focus on the selection of movement direction, and should thus be concerned with the core (Fox et al., 2009). The basal ganglia can thus be modeled based on existing (extended) models of the dorsal basal ganglia (Gurney et al., 2001a; Humphries and Gurney, 2002; Leblois et al.,

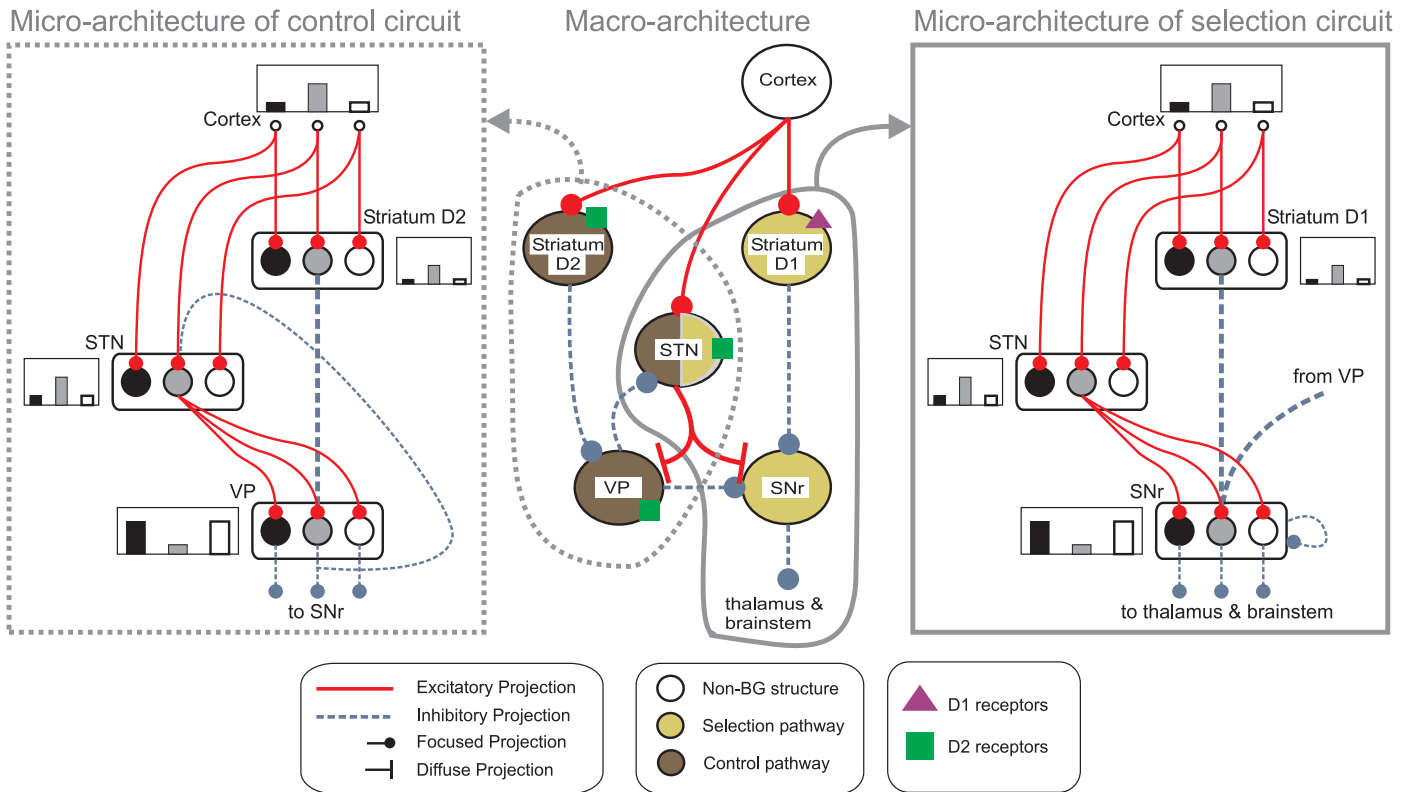

Figure 6: Selection architecture for the core-based subcircuit of the ventral basal ganglia. The main circuit (centre, simplification of Figure 2c) can be decomposed into two copies of an off-centre, on-surround network: a selection pathway (right) and a control pathway (left). Three parallel loops — channels — are shown in both pathways, with example activity levels in the bar charts to illustrate the relative contributions of the nuclei. Note that, for clarity, full connectivity is only shown for the second channel. Briefly, the selection mechanism works as follows. Constant inhibitory output from substantia nigra pars reticulata (SNr) provides an ‘off’ signal to its widespread targets in the thalamus and brainstem. Cortical inputs representing competing saliences are organised in separate channels (groups of co-active cortical neurons), which project to corresponding populations in striatum and subthalamic nucleus (STN). In the selection circuit, the balance of focussed inhibition from striatum and diffuse excitation from STN results in the most salient input suppressing the inhibitory output from SNr on that channel, signalling ‘on’ to that SNr channel’s targets. In the control circuit, a similar overlap of projections to pallidum exists (here ventral pallidum, VP), but the feedback from VP to the STN acts as a self-regulating mechanism for the activity in STN, which ensures that overall basal ganglia activity remains within operational limits as more and more channels become active. Tonic dopamine levels in the striatum set the ease with which the channels are selected, and subsequently switched between following further salient inputs. For quantitative demonstrations of this model see (Gurney et al., 2001b, 2004; Humphries et al., 2006).

2006) given the extensive parallels between the core and dorsal domains. Second, little hippocampal input reaches the core, and so it follows that the translation from model hippocampal place field activity to striatal input requires simulating either or both of the processing of this input by prefrontal cortical circuits and entorhinal cortex – far more complex interactions than current models, which only use CA1/CA3 place cells projecting directly to MSNs (Brown and Sharp, 1995b; Arleo and Gerstner, 2000; Chavarriga et al., 2005). In addition, there is a need to address competition and co-operation between movement direction coding channels that receive different information.

## 8.2. Theoretical roles of the NAcc shell

The two sub-circuits based respectively on the medial and lateral shell are clearly repeating computational units (Figure 2b). With neither containing any projections to the “classic” basal ganglia nuclei (STN/SNr/entopeduncular nucleus), it seems their entire intra-basal ganglia circuitry is dedicated to controlling the dynamics of the originating shell region.

### 8.2.1. Shell sub-circuits control dynamics of dopamine cells

The direct and indirect (via shell-VP and VP-PPn pathways) outputs to dopamine cells in VTA are strongly suggestive of a central role in shaping the dopamine response in the shell and core (Figure 7a). The dual pathway raises the possibility that a phasic output elicited in shell MSNs by correlated cortical inputs could produce both the phasic burst and the phasic dip of dopaminergic neuron firing. (These proposals must remain broad as details of the VP and PPn pathway to the VTA are lacking). As noted in section 5.5, these phasic changes famously have been observed in correlation with the presence or absence of rewards or their predictors and hence are of widespread interest, as they fit well with the behaviour of reward prediction error in reinforcement learning theory (Schultz et al., 1997; Waelti et al., 2001; Montague et al., 2004a).

A simple model of this sub-circuit shows how the phasic burst and dip can occur (see Appendix C for details). We can interpret this model within either the reward prediction error or action-outcome repertoire hypotheses. For the former, the dynamics of the sub-circuit suggest a mapping of pathways such that the shell-VTA direct pathway population encodes the predicted reward value, and the shell’s indirect pathway population encodes the value of the reward received. Given this mapping, the simple model shows that if encoded reward is greater than predicted, then a phasic burst of activity occurs in VTA (Figure 7b), and if reward is predicted but omitted then a phasic dip of activity occurs in VTA (Figure 7c). Further, we believe this points to a better mapping of the basal ganglia architecture on to the Actor-Critic framework for reinforcement learning (Joel et al., 2002), with explicit separation of the reward prediction error computation (shell sub-circuits implement the Critic(s)) from the selection of action (NAcc core circuit implements the Actor(s)).

We can equally interpret the phasic burst/dip control within the action-outcome repertoire framework. The current treatments (Redgrave and Gurney, 2006; Redgrave et al., 2008) focus on the role of direct superior colliculus input to SNc in

driving phasic bursts to novel phasic sensory stimuli (Dommett et al., 2005), and (along with parabrachial input to SNc) driving phasic dips in response to immediately aversive stimuli (Coizet et al., 2006; Redgrave et al., 2008). However, it is less clear how this extends to more complex outcomes than a phasic sensory stimulus, such as the position in space or in a behavioural sequence arrived at after the action is taken. We propose that the dual pathways of the shell-based sub-circuits provide a substrate for generating phasic dopamine bursts and dips in response to these more complex outcomes occurring or not.

One possible mapping of the shell sub-circuits’ dual pathways in this proposal is as follows: the direct shell-VTA pathway encodes the expected outcome – such as the position in space or within a task sequence – and the indirect pathway encodes the current outcome of the action. Then it follows that if an action is followed by a novel outcome, then the action is a candidate for adding to the repertoire or being retained, and the phasic dopamine time-stamp is elicited (Figure 7b). The time-stamp is elicited as only the indirect shell pathway will be active, and hence will generate a VTA neuron burst. Conversely, if the action did not elicit an expected outcome, then an “error” in that current action-outcome encoding is signalled by the dip in dopaminergic neuron activity (Figure 7c). It is not clear how the inputs to the direct and indirect shell pathways are segregated to support such a split encoding, but the confluence of mPFC, hippocampal formation, and amygdala input at least provide a plausible substrate for evaluating and predicting complex aspects of outcomes.

Irrespective of the framework used to interpret it, this model nicely reconciles the known involvement of many principal components of the neural substrate for reinforcement (whether of reward or causality): the value encoding in both the prefrontal cortex (section 5.2) and shell (section 6.1); the dominant projection from shell to VTA (section 3.2); the known regulation of VTA activity by ventral subiculum inputs to NAcc cells (Floresco et al., 2001b); and the critical role of PPn in controlling dopaminergic neuron burst firing (Floresco et al., 2003; Pan and Hyland, 2005). Indeed, in the most famous formal mapping of the dopaminergic neuron behaviour to reinforcement learning theory (Schultz et al., 1997), the prefrontal cortical projections to VTA were explicitly considered as the primary source for the shaping inputs; we believe the current proposal is more consistent with the VTA’s main GABAergic inputs from within the basal ganglia.

### 8.2.2. Simple selection by shell sub-circuits

Both sub-circuits also have outputs to the mediodorsal thalamus via the VP. This pathway is analogous to the direct striatal-SNr pathway of the core and dorsal striatum, but does not have the corresponding additional input to the SNr from the STN. Like the SNr (Chevalier and Deniau, 1990), stimulation of the VP causes short-latency inhibition in its thalamic targets (Lavin and Grace, 1994). In this respect, the shell-VP-thalamic projection is the simplest way of establishing a disinhibitory circuit, the canonical operation of the basal ganglia architecture. However, without STN input, it lacks the off-centre, on-

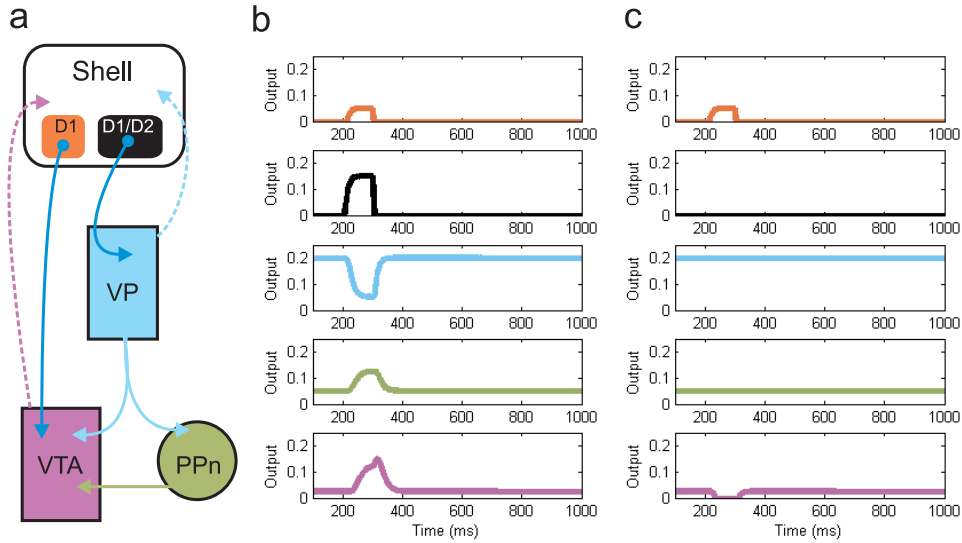

Figure 7: Potential control of dopaminergic VTA neurons by dual pathways originating from the shell. (a) The shell contains two VTA control sub-circuits of this design, originating from the medial and lateral divisions respectively (see Figure 2b). Each sub-circuit contains a direct (originating from D1-only MSNs) and indirect (originating from mixed D1 and D2 MSNs) pathway to the VTA. A population-level model of this sub-circuit illustrates the potential for shell control over dopaminergic neuron dynamics; each population’s output is given as normalised firing rate, and colour-coded by population (see Appendix C for details; dashed lines indicate connections omitted from the model). (b) If phasic input (from combined cortical, hippocampal, and amygdalar sources) to the indirect pathway is greater in magnitude than corresponding input to the direct pathway, a phasic burst results in VTA. Note that the model correctly captures the relative tonic output of the VP, PPn, and VTA neuron populations in the absence of cortically-driven striatal activity. (c) If the phasic input to the indirect pathway is omitted, a phasic dip results in VTA. The computational interpretation of the shell-driven burst/dip can be made in either the reward prediction error or action-outcome repertoire frameworks (see text).

surround network for creating competition between inputs, suggesting that these projections support multiple, parallel selections, rather than resolving competition in favour of a single input.

Parallel selections are consistent with the putative role of the complete prefrontal cortex-NAcc-VP-MD thalamus-prefrontal cortex loop in working memory (section 7.3). For, rather than competing for expression, each channel within this loop may separately maintain an item in working memory through the sustained activity of the positive feedback loop between cortex and thalamus (Goldman-Rakic, 1995). The role of VP-thalamic disinhibition is then to release a channel for the maintenance of a working memory item; the return of inhibition from VP to thalamus then removes it. Previous models have shown how the basal ganglia can provide such control over activity in the cortico-thalamic feedback loop (Humphries, 2002; Frank, 2005), and drawn parallels with working memory processes (Frank, 2005). However, no models to date have specifically addressed direct VP outflow to thalamus.

### 8.2.3. Multiple roles of each sub-circuit?

The medial shell certainly seems to have a number of functional roles, but no clear distinction in the anatomy of its outputs or purported function of its inputs along any axis, so we must assume that the functional circuitries are inter-mingled. The medial shell clearly has control over free-feeding, including locomotion associated with appetitive behaviour. Specifically, we propose that the channels defined by the convergent inputs from medial prefrontal cortex and amygdala are critical

for switching the global mode of behaviour away from free-feeding when necessary, for example when a fear-associated stimulus appears, via the direct output to lateral hypothalamus (though it is not clear why a second, disinhibitory, pathway to lateral hypothalamus via the VP is also present).

The medial shell may also have a role in computing the value of a stimulus-outcome pairing (Yin and Knowlton, 2006; Ikemoto, 2007), with its convergent input from amygdala and ventral subiculum. The study of Albertin et al. (2000) shows that medial shell is necessary for associating outcome magnitude (in their study, the number of water drops) with the correct spatial target, which for our purposes could be taken as synonymous with ‘stimulus’. Some authors have proposed a role for the shell as the locus of stimulus-outcome learning in instrumental conditioning (Yin and Knowlton, 2006; Ikemoto, 2007), and we propose that these conclusions apply equally well to spatial tasks: one way of approaching spatial navigation studies is to interpret them as simple instrumental conditioning tasks, where the action to be learnt is locomotion to a location, instead of a motor program.

The lateral shell has few direct targets, projecting only to the VTA and VP, and as such seems mostly dedicated to shaping the dopaminergic neuron output to itself and the core. The rostro-lateral shell is conceivably the part of the wider reward evaluation circuit dedicated to associating spatial or temporal positions with the presence of salient stimuli. It receives direct input from cells in the dorsal subiculum with multiple place fields, possible direct input from place cells in the dorsal CA1 region, widespread amygdala input carrying stimulus associated value

information, and prefrontal cortex input representing the anticipated value of the current action. The caudo-lateral shell may fulfill a similar role, as it has a similar circuit, but for stimuli that do not have (or need) a spatial or temporal position to distinguish them.

#### 8.2.4. Further model development

From this we can sketch a road-map for further computational model development. First, the dominant outputs of the shell and VP to lateral hypothalamus, and their proposed control over switching to and from free-feeding, point to a strong contribution in energy balance regulation. The lateral hypothalamus has long been known as a critical structure for energy regulation, being necessary for control of calorie intake (Grill and Kaplan, 2002). It has direct control over brainstem centres for movement (Sinnamon, 1993; Swanson, 2000), and feeds back to the striatum via thalamus (Kelley et al., 2005). All this suggests a tight striatal-hypothalamic control loop for the motor actions required in food acquisition and consumption.

Second, the repeating sub-circuits of the lateral and medial shell require further study in computational models. In particular, the model of dual pathway control of dopamine cells outlined above needs elaborating, to better understand both the potential time-scales of the phasic response they would elicit and how this fits together with the other functions of the shell. Finally, this dual pathway model can be extended to study the hierarchy of control created by medial shell's projections to lateral VTA, which in turn projects to the core and lateral shell, and to the medial SNc, which in turn projects to the dorsal striatum (Haber, 2003).

#### 8.3. Integration with the dorsal basal ganglia domains

This brings us full-circle to briefly consider how the ventral and dorsal basal ganglia domains interact. A clear substrate for interaction is provided by the just-described dopamine "spiral" of successive projections from striatal regions to dopamine cells that project to the adjacent striatal region, in a shell-core-DMS-DLS sequence (Maurin et al., 1999; Haber et al., 2000). Haber (2003) has also argued that connections between cortical areas projecting to these striatal regions parallel the spiral, with shell projecting cortical regions providing more feedforward inputs to than receiving feedback inputs from core-projecting cortical regions, and so on. Further, cortical projections to the striatal regions also tend to extend across to part of the adjacent striatal region in the shell-core-DMS-DLS sequence (Haber, 2003). These hierarchies of anatomical connections underpin theories about the three basal ganglia domains providing a hierarchy of control (Redgrave et al., 1999a; Joel and Weiner, 2000b), such as respectively being responsible for selection of a goal (ventral striatum), an action to achieve that goal (DMS), and a motor program to implement that action (DLS).

A considerable body of evidence suggests a functional hierarchy between the DMS and DLS. Lesion studies have demonstrated that an intact DMS is necessary for an animal to show awareness of contingencies between actions and outcomes, changing its actions as the value or probability of the outcome changes, and an intact DLS is necessary for establishing

habits, where contingency changes no longer affect the action (Yin and Knowlton, 2006). Moreover, the switch from awareness of action-outcome contingencies to habitual behaviour occurs through over-training, suggesting a passing of control from DMS to DLS domains of the basal ganglia (Daw et al., 2005; Yin and Knowlton, 2006; Hilario and Costa, 2008). The role of ventral striatum in this process has received little attention; for example, the major review by Yin and Knowlton (2006) refers to it in passing as the site of Pavlovian-instrumental transfer, the use of conditioned stimulus-outcome pairings in instrumental tasks, and other classical conditioning-based phenomena. These roles stand in stark contrast to the complexity of the behavioural and neural activity correlates listed above.

Let us close by speculating on how the ventral basal ganglia may fit into the action-outcome contingency and habitual behaviour story. We suggest that this learning literature, and the computational theories of dopamine discussed previously, point to a two-stage process of learning in a novel environment, first establishing the outline of the required sequence of actions, and, second, the expression of that learning, in which the sequence is optimised and progressively automatised. For the dopamine theories, we contend that action-outcome repertoire learning underpins the former (novel learning), and incentive salience/reward prediction error the latter (expression), both driven by the same phasic dopamine signals. Further, it seems to us that both the use of action-outcome contingencies and the transfer to habitual behaviour are part of the *expression* of learnt action-outcome repertoires, respectively corresponding to the optimisation of action sequences and their automatised (should the environment be stable enough to warrant it). Consider that constructing a sequence of actions, each with its associated outcome, requires episodic replay of past behaviour, so that the actions can be performed repeatedly while their outcomes and their sequence are being learnt. Where then does this replay come from? We suggest that the ventral striatum, at the convergence of hippocampal formation and prefrontal cortex circuits for replay of memory and dopamine signals for learning, is necessary for controlling the behavioural expression of episodic memory replay and, via the dual shell pathway mechanism above, eliciting phasic dopamine bursts to reinforce each stage of behaviour as a part of an action sequence.

## 9. Conclusions

The ventral basal ganglia domain can be cleanly divided in two. On one hand, the nucleus accumbens core and associated regions of other basal ganglia nuclei form a clear homologue of the dorsolateral and dorsomedial basal ganglia, and so we extend the selection hypothesis to this circuit too. On the other, the nucleus accumbens shell sits as the gateway to a much simplified basal ganglia circuit, but also to more complex interactions directly with the rest of the brain. Within these divisions, we can again subdivide according to internal anatomy or patterns of external input, and along all three axes of the brain, resulting in a bewildering number of potential conjunctions of information, both input and output. We have brought together a considerable breadth of current neuroscience knowledge in

our attempt to determine the putative functions of these identified subdivisions, trying to match the constraints given by the anatomy to the correlates of neural activity and the behavioural deficits of broad brush lesions and neurochemical manipulations. In doing so, we have had to suggest resolutions for numerous ongoing issues so that we may move forward in our attempts to understand ventral basal ganglia's contribution to voluntary behaviour. We gather the principal novel conclusions and predictions from this work in Appendix A; the numerous open questions we identified are gathered in Appendix B.

Our proposals for the functional roles of the main core- and shell-based basal ganglia circuits range from the definite and testable to the speculative; the latter principally due to a dearth of knowledge about the main input structures. Nonetheless, we have now established as detailed a picture for the ventral basal ganglia domain as currently exists for its dorsal counterparts, and are undoubtedly in a better position to turn now to the question of how these three domains interact.

### Acknowledgements

We thank Peter Redgrave for comments on earlier versions of this manuscript; and Mehdi Khamassi for stimulating feedback, new literature sources, and drawing our attention to some of the problems in the ventral striatal literature. This work was funded by the European Union Framework 6 IST 027819 ICEA project.

### A. Novel conclusions and predictions

In addition to the large-scale functional proposals in section 8, we have reached a number of new conclusions and predictions in this review. Given the length and complexity of the preceding work, we gather these here for convenience:

- The dopamine-receptor defined sub-populations of MSNs in the core have analogous targets to their counterparts in the dorsal striatum. Only D1 MSNs within the core project to the SNr; core D2 MSNs only project to the VP; the D1 MSNs send a considerable number of collaterals to the VP too [section 3.1 and Figure 2c].
- In the rostral core, the 'patch' is the continuous region of cells: defined by calbindin-poor regions, receiving input from deep layer V of cortex, and whose MSNs project predominantly to brainstem dopamine cells [section 3.1.1].
- Core 'patches' are exclusively made up of D1 MSNs — thus only D1 MSNs project to dopamine cells. This is in contrast to dorsal striatum patches, which contain fully intermingled D1 and D2 MSNs [section 3.1.1].
- The shell has two dopamine-receptor defined output pathways: a mixture of D1 and D2 MSNs project to VP; shell D1 MSNs alone project to VTA. Thus, just like the core, only D1 MSNs seem to project to dopamine cells [section 3.2 and Figure 2b].

- The shell dual-pathway structure is itself repeated twice. Projections from lateral shell target VPvl and VTAl, respectively; projections from medial shell target VPM and VTAm, respectively [section 3.2 and Figure 2b].
- The inverse gradient of FS interneurons and LTS interneurons across the dorsolateral-ventromedial axis of the striatum does not exist. The FS interneurons show a decrease in number along this axis, but current evidence suggests the LTS interneurons show no monotonic variation along this axis [section 3.3.1].
- The PPN is positioned to provide a further indirect, disinhibitory path, from the shell to the VTA [section 3.3.2].
- Pre-synaptic dopamine receptors on glutamatergic terminals in ventral striatum are different for different afferents: prefrontal cortical terminals express D2-like receptors; hippocampal and amygdala terminals express D1-like receptors.
- Hippocampal formation input to ventral striatum does not fit current theories of interaction with basal ganglia. Main contributor is the subiculum, not the classic place cells of CA1; the main target is the shell [section 5.1.1 and Figure 3a].
- Medial core MSNs receive considerable projections from layers of MEC that contain both grid and grid/direction conjunction cells [section 5.1.1 and Figure 3a]. Medial core is thus in a position to decode spatial location directly.
- Medial shell is an active contributor to the inhibition of free-feeding behaviour [section 6.1].
- Multiple channels (40+) across core and shell are defined by each set of MSNs receiving a unique overlap of inputs [section 7].

### B. Open questions

Throughout we have noted a number of open questions, and topics on which data is sorely lacking. We gather these here for convenience:

- Does STN reciprocate the projections from VPdl within the core-based circuit? We have assumed here that it does, following the projection patterns between STN and dorsal pallidum (GP); nonetheless, we are unaware of a direct examination of STN's projections to VP.
- Does VP have the same internal structure as GP? Sadek et al. (2007) have demonstrated a two-layer network supporting feed-forward and feed-back inhibition within GP. We suspect that at least the portion of VP (VPdl) within the core-based circuit will have a similar structure; but the unique outputs of VP subregions within the shell-based circuits may correspond to different internal structure.

- Which regions of VTA and mSNc project to STN and VP? Both closed and open-loop projections are possible here, but we are unaware of any studies that have examined this.
- Does VP preferentially target the fast-spiking and LTS interneurons of the ventral striatum? We have assumed here that it does, following evidence for the GP and dorsal striatum (Bevan et al., 1998).
- What dopamine-receptor subpopulations (D1 or D2) do shell projections outside the basal ganglia originate from? We have gathered evidence here for distinct D1 and D1/D2 mixed subpopulations and their targets within basal ganglia; but whether or not these remain distinct when considering external projections is not known.
- Do STN, SNr, and VP outputs overlap in PPN?
- What are the detailed effects of core or shell stimulation on their respective dopaminergic cell targets?
- What is the extent of CA1 participation in projections to the NAcc? Existing evidence suggests that it is comparatively minor compared to subiculum, but a systematic study of CA1 projections to NAcc is lacking.
- What is the patterning of MD thalamus input to NAcc? Primate studies suggest this structure only projects to the core.
- Does LEC encode configurations of objects for context recognition?
- What specific role does vSub play in instrumental conditioning?
- Do rostro-medial core MSNs decode place information from MEC grid neuron input?
- Do lateral core MSNs decode place from object configurations in LEC?
- Are there high-level goal or strategy planning functions associated uniquely with the putative rodent equivalent to dorsolateral prefrontal cortex?

### C. Population-level model of shell sub-circuit

We model the sub-circuit shown in Figure 7a at mean-field population-level (Wilson and Cowan, 1972), with each populations' normalised firing rate  $y$  given by

$$\tau \dot{a} = -a + I \quad (1)$$

$$y = f(a), \quad (2)$$

where  $I$  is the total input to the population, and  $\tau$  is a time constant for changes in activity — we use  $\tau = 10$  ms throughout. Here we choose the output function  $f(a)$  to be a linear ramp

$$y = f(a, \epsilon) = \begin{cases} 0, & \text{if } a < \epsilon; \\ a - \epsilon, & \text{if } \epsilon \leq a \leq 1 + \epsilon \\ 1, & \text{if } a > 1 + \epsilon \end{cases} \quad (3)$$

with threshold  $\epsilon$ .

We model five populations: a “direct” shell population with D1 receptors that project to VTA; an “indirect” shell population, both D1 and D2 MSNs, projecting to VP; and VP, PPN, and VTA populations. The full model is given by the system

$$\text{Shell (direct):} \quad I_d = c_d, \quad (4)$$

$$y_d = f(a_d, \epsilon_d), \quad (5)$$

$$\text{Shell (indirect):} \quad I_i = c_i, \quad (6)$$

$$y_i = f(a_i, \epsilon_i), \quad (7)$$

$$\text{VP:} \quad I_{vp} = w_{i-vp} y_i, \quad (8)$$

$$y_{vp} = f(a_{vp}, \epsilon_{vp}), \quad (9)$$

$$\text{PPn:} \quad I_{ppn} = w_{vp-ppn} y_{vp}, \quad (10)$$

$$y_{ppn} = f(a_{ppn}, \epsilon_{ppn}), \quad (11)$$

$$\text{VTA:} \quad I_{vta} = w_{d-vta} y_d + w_{vp-vta} y_{vp} + w_{ppn-vta} y_{ppn}, \quad (12)$$

$$y_{vta} = f(a_{vta}, \epsilon_{vta}). \quad (13)$$

Cortical input ( $c_d, c_i$ ) to the two striatal populations was modelled as a phasic pulse. For the simulation in Figure 7b,  $c_d = 0.25$  and  $c_i = 0.35$  for 100ms, and were 0 otherwise; these relative values represent the case of greater reward received than predicted. For the simulation in Figure 7c, only  $c_d$  was set to 0.25 for 100ms, representing reward predicted, but omitted ( $c_i = 0$ ).

The magnitudes of the weighted projections between populations were somewhat arbitrary, but chosen to reflect known properties of the neural circuit. For the simulations shown in Figure 7, we use weights of:  $w_{d-vta} = w_{i-vp} = -1$ , to model the large convergence of inhibitory projections from striatum to its targets in the basal ganglia;  $w_{vp-ppn} = w_{vp-ppn} = -0.5$ , to model the comparatively smaller contribution of VP inhibition; and  $w_{ppn-vta} = 1$ , to model the important role played by cholinergic (presumably PPN originating) inputs in controlling output of dopaminergic cells (Kitai et al., 1999; Floresco et al., 2003). All connections had a fixed transmission delay of 5 ms.

The magnitudes of the thresholds were also chosen to reflect known properties of the neurons in each population. Hence, we set:  $\epsilon_d = \epsilon_i = 0.2$ , so that substantial cortical input was required for the shell MSN populations to respond; and  $\epsilon_{vp} = -0.2$ ,  $\epsilon_{ppn} = -0.15$ , and  $\epsilon_{vta} = -0.075$ , so that all of these populations had stable tonic output. Note particularly that the VTA population thus had a low tonic output rate.

The model code was written in MATLAB (Mathworks) and solved using a zero-order hold (or “exponential Euler”) method using 1 ms time-steps. We show all population outputs  $y$  after the initial 100ms, so that initial simulation transients had settled.

### References

- Aizman, O., Brismar, H., Uhlen, P., Zettergren, E., Levey, A. I., Forsberg, H., Greengard, P., Aperia, A., 2000. Anatomical and physiological evidence for D1 and D2 dopamine receptor colocalization in neostriatal neurons. *Nature Neurosci* 3, 226–230.

- Albertin, S. V., Mulder, A. B., Tabuchi, E., Zugaro, M. B., Wiener, S. I., 2000. Lesions of the medial shell of the nucleus accumbens impair rats in finding larger rewards, but spare reward-seeking behavior. *Behav Brain Res* 117, 173–183.
- Albin, R. L., Young, A. B., Penney, J. B., 1989. The functional anatomy of basal ganglia disorders. *Trends Neurosci* 12, 366–375.
- Alexander, G. E., Crutcher, M. D., 1990. Functional architecture of basal ganglia circuits: neural substrates of parallel processing. *Trends Neurosci* 13, 266–272.
- Alexander, G. E., DeLong, M. R., 1985. Microstimulation of the primate neostriatum. II. Somatotopic organization of striatal microexcitable zones and their relation to neuronal response properties. *J Neurophysiol* 53, 1417–1430.
- Alexander, G. E., DeLong, M. R., Strick, P. L., 1986. Parallel organization of functionally segregated circuits linking basal ganglia and cortex. *Annu Rev Neurosci* 9, 357–381.
- Allen, L. F., Inglis, W. L., Winn, P., 1996. Is the cuneiform nucleus a critical component of the mesencephalic locomotor region? An examination of the effects of excitotoxic lesions of the cuneiform nucleus on spontaneous and nucleus accumbens induced locomotion. *Brain Res Bull* 41, 201–210.
- Ambroggi, F., Ishikawa, A., Fields, H. L., Nicola, S. M., 2008. Basolateral amygdala neurons facilitate reward-seeking behavior by exciting nucleus accumbens neurons. *Neuron* 59, 648–661.
- Anderson, M. I., Killing, S., Morris, C., O'Donoghue, A., Onyiah, D., Stevenson, R., Verriotis, M., Jeffery, K. J., 2006. Behavioral correlates of the distributed coding of spatial context. *Hippocampus* 16, 730–742.
- Aosaki, T., Tsubokawa, H., Ishida, A., Watanabe, K., Graybiel, A. M., Kimura, M., 1994. Responses of tonically active neurons in the primate's striatum undergo systematic changes during behavioral sensorimotor conditioning. *J Neurosci* 14, 3969–3984.
- Apicella, P., Scarnati, E., Schultz, W., 1991. Tonicly discharging neurons of monkey striatum respond to preparatory and rewarding stimuli. *Exp Brain Res* 84, 672–675.
- Arleo, A., Gerstner, W., 2000. Spatial cognition and neuro-mimetic navigation: a model of hippocampal place cell activity. *Biol Cybern* 83, 287–299.
- Armory, J. L., Servan-Schreiber, D., Romanski, L. M., Cohen, J. D., LeDoux, J. E., 1997. Stimulus generalization of fear responses: effects of auditory cortex lesions in a computational model and in rats. *Cereb Cortex* 7, 157–165.
- Balleine, B. W., Killcross, A. S., Dickinson, A., 2003. The effect of lesions of the basolateral amygdala on instrumental conditioning. *J Neurosci* 23, 666–675.
- Bamford, N. S., Zhang, H., Schmitz, Y., Wu, N. P., Cepeda, C., Levine, M. S., Schmauss, C., Zakharenko, S. S., Zablow, L., Sulzer, D., 2004. Heterosynaptic dopamine neurotransmission selects sets of corticostriatal terminals. *Neuron* 42, 653–663.
- Bassareo, V., Chiara, G. D., 1999. Differential responsiveness of dopamine transmission to food-stimuli in nucleus accumbens shell/core compartments. *Neuroscience* 89, 637–641.
- Bassareo, V., Luca, M. A. D., Chiara, G. D., 2002. Differential expression of motivational stimulus properties by dopamine in nucleus accumbens shell versus core and prefrontal cortex. *J Neurosci* 22, 4709–4719.
- Battaglia, F. P., Khamassi, M., Peyrache, A., Douchamps, V., Tierney, P., Wiener, S. I., 2006a. Spatial and reward correlates in medial prefrontal neurons of rats acquiring and switching strategies in a Y-maze. In: 2006 Neuroscience Meeting Planner. Society for Neuroscience, Atlanta, GA, p. Program No. 573.13.
- Battaglia, F. P., Khamassi, M., Peyrache, A., Douchamps, V., Tierney, P., Wiener, S. I., 2006b. Transitions in behaviorally correlated activity in medial prefrontal neurons of rats acquiring and switching strategies in a Y-maze. In: 2006 Neuroscience Meeting Planner. Society for Neuroscience, Atlanta, GA, p. Program No. 573.12.
- Bauter, M. R., Brockel, B. J., Pankevich, D. E., Virgolini, M. B., Cory-Slechta, D. A., 2003. Glutamate and dopamine in nucleus accumbens core and shell: sequence learning versus performance. *Neurotoxicology* 24, 227–243.
- Bayer, H. M., Glimcher, P. W., 2005. Midbrain dopamine neurons encode a quantitative reward prediction error signal. *Neuron* 47, 129–141.
- Bayer, H. M., Lau, B., Glimcher, P. W., 2007. Statistics of midbrain dopamine neuron spike trains in the awake primate. *J Neurophysiol* 98, 1428–1439.
- Beiser, D. G., Houk, J. C., 1998. Model of cortical-basal ganglionic processing: Encoding the serial order of sensory events. *J Neurophysiol* 79, 3168–3188.
- Bennett, A. T., 1996. Do animals have cognitive maps? *J Exp Biol* 199, 219–224.
- Bennett, B. D., Wilson, C. J., 1998. Synaptic regulation of action potential timing in neostriatal cholinergic interneurons. *J Neurosci* 18, 8539–8549.
- Benoit-Marand, M., Borrelli, E., Gonon, F., 2001. Inhibition of dopamine release via presynaptic D2 receptors: time course and functional characteristics in vivo. *J Neurosci* 21, 9134–9141.
- Berendse, H. W., de Graaf, Y. G., Groenewegen, H. J., 1992a. Topographical organization and relationship with ventral striatal compartments of prefrontal corticostriatal projections in the rat. *J Comp Neurol* 316, 314–347.
- Berendse, H. W., Groenewegen, H. J., Lohman, A. H., 1992b. Compartmental distribution of ventral striatal neurons projecting to the mesencephalon in the rat. *J Neurosci* 12, 2079–2103.
- Berke, J. D., Okatan, M., Skurski, J., Eichenbaum, H. B., 2004. Oscillatory entrainment of striatal neurons in freely moving rats. *Neuron* 43, 883–896.
- Berns, G. S., Sejnowski, T. J., 1998. A computational model of how the basal ganglia produce sequences. *J Cogn Neurosci* 10, 108–121.
- Berridge, K. C., 2007. The debate over dopamine's role in reward: the case for incentive salience. *Psychopharmacology (Berl)* 191 (3), 391–431.
- Bertran-Gonzalez, J., Bosch, C., Maroteaux, M., Matamalas, M., Herv, D., Valjent, E., Girault, J.-A., 2008. Opposing patterns of signaling activation in dopamine D1 and D2 receptor-expressing striatal neurons in response to cocaine and haloperidol. *J Neurosci* 28, 5671–5685.
- Bevan, M. D., Booth, P. A. C., Eaton, S. A., Bolam, J. P., 1998. Selective innervation of neostriatal interneurons by a subclass of neuron in the globus pallidus of the rat. *J Neurosci* 18, 9438–9452.
- Bevan, M. D., Magill, P. J., Terman, D., Bolam, J. P., Wilson, C. J., 2002. Move to the rhythm: oscillations in the subthalamic nucleus-external globus pallidus network. *Trends Neurosci* 25, 525–531.
- Bjorklund, A., Dunnett, S. B., 2007. Dopamine neuron systems in the brain: an update. *Trends Neurosci* 30, 194–202.
- Boeijinga, P. H., Mulder, A. B., Pennartz, C. M., Manshanden, I., da Silva, F. H. L., 1993. Responses of the nucleus accumbens following fornix/fimbria stimulation in the rat. Identification and long-term potentiation of mono- and polysynaptic pathways. *Neuroscience* 53, 1049–1058.
- Bolam, J. P., Hanley, J. J., Booth, P. A., Bevan, M. D., 2000. Synaptic organization of the basal ganglia. *J Anat* 196, 527–542.
- Bracci, E., Centonze, D., Bernardi, G., Calabresi, P., 2002. Dopamine excites fast-spiking interneurons in the striatum. *J Neurophysiol* 87, 2190–2194.
- Brady, A. M., O'Donnell, P., 2004. Dopaminergic modulation of prefrontal cortical input to nucleus accumbens neurons in vivo. *J Neurosci* 24, 1040–1049.
- Brown, L. L., Sharp, F. R., 1995a. Metabolic mapping of rat striatum: somatotopic organization of sensorimotor activity. *Brain Res* 686, 207–222.
- Brown, L. L., Smith, D. M., Goldbloom, L. M., 1998. Organizing principles of cortical integration in the rat neostriatum: Corticostriate map of the body surface is an ordered lattice of curved laminae and radial points. *J Comp Neurol* 392, 468–488.
- Brown, M. A., Sharp, P. E., 1995b. Simulation of spatial learning in the Morris water maze by a neural network model of the hippocampal formation and nucleus accumbens. *Hippocampus* 5, 171–188.
- Burn, C. C., 2008. What is it like to be a rat? rat sensory perception and its implications for experimental design and rat welfare. *Applied Animal Behaviour Science* 112, 1–32.
- Calabresi, P., Picconi, B., Tozzi, A., Filippo, M. D., 2007. Dopamine-mediated regulation of corticostriatal synaptic plasticity. *Trends Neurosci* 30, 211–219.
- Canteras, N. S., Shammah-Lagnado, S. J., Silva, B. A., Ricardo, J. A., 1990. Afferent connections of the subthalamic nucleus: a combined retrograde and anterograde horseradish peroxidase study in the rat. *Brain Res* 513, 43–59.
- Cardinal, R. N., Parkinson, J. A., Hall, J., Everitt, B. J., 2003. The contribution of the amygdala, nucleus accumbens, and prefrontal cortex to emotion and motivated behaviour. *International Congress Series* 1250, 347–370.
- Carr, D. B., Sesack, S. R., 2000. Projections from the rat prefrontal cortex to the ventral tegmental area: target specificity in the synaptic associations with mesoaccumbens and mesocortical neurons. *J Neurosci* 20, 3864–3873.
- Castle, M., Aymerich, M. S., Sanchez-Escobar, C., Gonzalo, N., Obeso, J. A., Lanciego, J. L., 2005. Thalamic innervation of the direct and indirect basal ganglia pathways in the rat: Ipsi- and contralateral projections. *J Comp Neurol* 483, 143–153.
- Cenquizca, L. A., Swanson, L. W., 2007. Spatial organization of direct hip-

- pocampal field CA1 axonal projections to the rest of the cerebral cortex. *Brain Res Rev* 56, 1–26.
- Centonze, D., Bracci, E., Pisani, A., Gubellini, P., Bernardi, G., Calabresi, P., 2002. Activation of dopamine D1-like receptors excites LTS interneurons of the striatum. *Eur J Neurosci* 15, 2049–2052.
- Centonze, D., Grande, C., Usiello, A., Gubellini, P., Erbs, E., Martin, A. B., Pisani, A., Tognazzi, N., Bernardi, G., Moratalla, R., Borrelli, E., Calabresi, P., 2003. Receptor subtypes involved in the presynaptic and postsynaptic actions of dopamine on striatal interneurons. *J Neurosci* 23, 6245–6254.
- Cepeda, C., Hurst, R. S., Altemus, K. L., Flores-Hernandez, J., Calvert, C. R., Jokel, E. S., Grandy, D. K., 2001. Facilitated glutamatergic transmission in the striatum of D2 dopamine receptor-deficient mice. *J Neurophysiol* 85, 659–670.
- Chang, J. Y., Janak, P. H., Woodward, D. J., 2000. Neuronal and behavioral correlations in the medial prefrontal cortex and nucleus accumbens during cocaine self-administration by rats. *Neuroscience* 99, 433–443.
- Charara, A., Grace, A. A., 2003. Dopamine receptor subtypes selectively modulate excitatory afferents from the hippocampus and amygdala to rat nucleus accumbens neurons. *Neuropsychopharmacology* 28, 1412–1421.
- Chavariaga, R., Strsslin, T., Sheynikhovich, D., Gerstner, W., 2005. A computational model of parallel navigation systems in rodents. *Neuroinformatics* 3, 223–241.
- Cheng, J., Feenstra, M. G. P., 2006. Individual differences in dopamine efflux in nucleus accumbens shell and core during instrumental learning. *Learn Mem* 13, 168–177.
- Chevalier, G., Deniau, J. M., 1990. Disinhibition as a basic process in the expression of striatal function. *Trends Neurosci* 13, 277–280.
- Coizet, V., Dommett, E. J., Redgrave, P., Overton, P. G., 2006. Nociceptive responses of midbrain dopaminergic neurones are modulated by the superior colliculus in the rat. *Neuroscience* 139, 1479–1493.
- Contreras-Vidal, J. L., Stelmach, G. E., 1995. A neural model of basal ganglia-thalamocortical relations in normal and parkinsonian movement. *Biol Cybern* 73, 467–476.
- Corbit, L. H., Balleine, B. W., 2003. The role of prefrontal cortex in instrumental conditioning. *Behav Brain Res* 146, 145–157.
- Coutureau, E., Killcross, S., 2003. Inactivation of the infralimbic prefrontal cortex reinstates goal-directed responding in overtrained rats. *Behav Brain Res* 146, 167–174.
- Cragg, S. J., 2006. Meaningful silences: how dopamine listens to the ACh pause. *Trends Neurosci* 29, 125–131.
- Cragg, S. J., Rice, M. E., 2004. Dancing past the DAT at a DA synapse. *Trends Neurosci* 27, 270–277.
- da Silva, F. H. L., Arnolds, D. E., Neijt, H. C., 1984. A functional link between the limbic cortex and ventral striatum: physiology of the subiculum accumbens pathway. *Exp Brain Res* 55, 205–214.
- Dalley, J. W., Cardinal, R. N., Robbins, T. W., 2004. Prefrontal executive and cognitive functions in rodents: neural and neurochemical substrates. *Neurosci Biobehav Rev* 28, 771–784.
- Davis, M., Walker, D. L., Lee, Y., 1997. Amygdala and bed nucleus of the stria terminalis: differential roles in fear and anxiety measured with the acoustic startle reflex. *Philos Trans R Soc Lond B Biol Sci* 352, 1675–1687.
- Daw, N. D., Niv, Y., Dayan, P., 2005. Uncertainty-based competition between prefrontal and dorsolateral striatal systems for behavioral control. *Nat Neurosci* 8, 1704–1711.
- Day, J. J., Roitman, M. F., Wightman, R. M., Carelli, R. M., 2007. Associative learning mediates dynamic shifts in dopamine signaling in the nucleus accumbens. *Nat Neurosci* 10, 1020–1028.
- Day, M., Wokosin, D., Plotkin, J. L., Tian, X., Surmeier, D. J., 2008. Differential excitability and modulation of striatal medium spiny neuron dendrites. *J Neurosci* 28, 11603–11614.
- Deng, P., Zhang, Y., Xu, Z. C., 2007. Involvement of I(h) in dopamine modulation of tonic firing in striatal cholinergic interneurons. *J Neurosci* 27, 3148–3156.
- Deniau, J. M., Chevalier, G., 1985. Disinhibition as a basic process in the expression of striatal functions. II. the striato-nigral influence on thalamocortical cells of the ventromedial thalamic nucleus. *Brain Res* 334, 227–233.
- Deniau, J. M., Chevalier, G., 1992. The lamellar organization of the rat substantia nigra pars reticulata: distribution of projection neurons. *Neuroscience* 46, 361–377.
- Deniau, J. M., Menetrey, A., Charpier, S., 1996. The lamellar organization of the rat substantia nigra pars reticulata: segregated patterns of striatal afferents and relationship to the topography of corticostriatal projections. *Neuroscience* 73, 761–781.
- Deniau, J. M., Menetrey, A., Thierry, A. M., 1994. Indirect nucleus accumbens input to the prefrontal cortex via the substantia nigra pars reticulata: a combined anatomical and electrophysiological study in the rat. *Neuroscience* 61, 533–545.
- der Werf, Y. D. V., Witter, M. P., Groenewegen, H. J., 2002. The intralaminar and midline nuclei of the thalamus. Anatomical and functional evidence for participation in processes of arousal and awareness. *Brain Res Brain Res Rev* 39, 107–140.
- Desjardins, C., Parent, A., 1992. Distribution of somatostatin immunoreactivity in the forebrain of the squirrel monkey: basal ganglia and amygdala. *Neuroscience* 47, 115–133.
- Dommett, E., Coizet, V., Blaha, C. D., Martindale, J., Lefebvre, V., Walton, N., Mayhew, J. E., Overton, P. G., Redgrave, P., 2005. How visual stimuli activate dopaminergic neurons at short latency. *Science* 307, 1476–1479.
- Dumartin, B., Doudnikoff, E., Gonon, F., Bloch, B., 2007. Differences in ultrastructural localization of dopaminergic D1 receptors between dorsal striatum and nucleus accumbens in the rat. *Neurosci Lett* 419, 273–277.
- Eichenbaum, H., Dudchenko, P., Wood, E., Shapiro, M., Tanila, H., 1999. The hippocampus, memory, and place cells: is it spatial memory or a memory space? *Neuron* 23, 209–226.
- Erro, M. E., Lanciego, J. L., Gimenez-Amaya, J. M., 2002. Re-examination of the thalamostriatal projections in the rat with retrograde tracers. *Neurosci Res* 42.
- Etienne, A. S., Jeffery, K. J., 2004. Path integration in mammals. *Hippocampus* 14, 180–192.
- Feierstein, C. E., Quirk, M. C., Uchida, N., Sosulski, D. L., Mainen, Z. F., 2006. Representation of spatial goals in rat orbitofrontal cortex. *Neuron* 51, 495–507.
- Fernandez, E., Schiappa, R., Girault, J.-A., Novre, N. L., 2006. DARPP-32 is a robust integrator of dopamine and glutamate signals. *PLoS Comput Biol* 2, e176.
- Fiete, I. R., Burak, Y., Brookings, T., 2008. What grid cells convey about rat location. *J Neurosci* 28, 6858–6871.
- Finch, D. M., 1996. Neurophysiology of converging synaptic inputs from the rat prefrontal cortex, amygdala, midline thalamus, and hippocampal formation onto single neurons of the caudate/putamen and nucleus accumbens. *Hippocampus* 6, 495–512.
- Floresco, S. B., Blaha, C. D., Yang, C. R., Phillips, A. G., 2001a. Modulation of hippocampal and amygdalar-evoked activity of nucleus accumbens neurons by dopamine: cellular mechanisms of input selection. *J Neurosci* 21, 2851–2860.
- Floresco, S. B., Braaksma, D. N., Phillips, A. G., 1999. Thalamic-cortical-striatal circuitry subserves working memory during delayed responding on a radial arm maze. *J Neurosci* 19, 11061–11071.
- Floresco, S. B., Seamans, J. K., Phillips, A. G., 1997. Selective roles for hippocampal, prefrontal cortical, and ventral striatal circuits in radial-arm maze tasks with or without a delay. *J Neurosci* 17, 1880–1890.
- Floresco, S. B., Todd, C. L., Grace, A. A., 2001b. Glutamatergic afferents from the hippocampus to the nucleus accumbens regulate activity of ventral tegmental area dopamine neurons. *J Neurosci* 21, 4915–4922.
- Floresco, S. B., West, A. R., Ash, B., Moore, H., Grace, A. A., 2003. Afferent modulation of dopamine neuron firing differentially regulates tonic and phasic dopamine transmission. *Nat Neurosci* 6, 968–973.
- Foo, P., Warren, W. H., Duchon, A., Tarr, M. J., 2005. Do humans integrate routes into a cognitive map? Map- versus landmark-based navigation of novel shortcuts. *J Exp Psychol Learn Mem Cogn* 31, 195–215.
- Foster, D. J., Wilson, M. A., 2006. Reverse replay of behavioural sequences in hippocampal place cells during the awake state. *Nature* 440, 680–683.
- Fox, C., Humphries, M., Mitchinson, B., Kiss, T., Somogyvari, Z., Prescott, T., 2009. Technical integration of hippocampus, basal ganglia and physical models for spatial navigation. *Front Neuroinform* 3, 6.
- Frank, M. J., 2005. Dynamic dopamine modulation in the basal ganglia: a neurocomputational account of cognitive deficits in medicated and nonmedicated Parkinsonism. *J Cogn Neurosci* 17, 51–72.
- French, S. J., Totterdell, S., 2002. Hippocampal and prefrontal cortical inputs monosynaptically converge with individual projection neurons of the nucleus accumbens. *J Comp Neurol* 446, 151–165.
- Friedman, D. P., Aggleton, J. P., Saunders, R. C., 2002. Comparison of hippocampal, amygdala, and perirhinal projections to the nucleus accumbens:

combined anterograde and retrograde tracing study in the macaque brain. *J Comp Neurol* 450, 345–365.

Futami, T., Takakusaki, K., Kitai, S. T., 1995. Glutamatergic and cholinergic inputs from the pedunculopontine tegmental nucleus to dopamine neurons in the substantia nigra pars compacta. *Neurosci Res* 21, 331–342.

Gerfen, C., Engber, T., Mahan, L., Susel, Z., Chase, T., Monsma, F., Sibley, D., 1990. D1 and D2 dopamine receptor-regulated gene expression of striatonigral and striatopallidal neurons. *Science* 250, 1429–1432.

Gerfen, C., Wilson, C., 1996. The basal ganglia. In: Swanson, L., Bjorklund, A., Hokfelt, T. (Eds.), *Handbook of chemical neuroanatomy. Vol 12: Integrated systems of the CNS. Part III.* Elsevier, Amsterdam, pp. 371–468.

Gerfen, C. R., 1984. The neostriatal mosaic: compartmentalization of corticostriatal input and striatonigral output systems. *Nature* 311, 461–464.

Gerfen, C. R., 2004. Basal ganglia. In: Paxinos, G. (Ed.), *The Rat Nervous System, Third Edition.* Academic Press, San Diego, CA, pp. 455–508.

Gerfen, C. R., Baimbridge, K. G., Miller, J. J., 1985. The neostriatal mosaic: compartmental distribution of calcium-binding protein and parvalbumin in the basal ganglia of the rat and monkey. *Proc Natl Acad Sci U S A* 82, 8780–8784.

Gerfen, C. R., Herkenham, M., Thibault, J., 1987. The neostriatal mosaic: II. Patch- and matrix-directed mesostriatal dopaminergic and non-dopaminergic systems. *J Neurosci* 7, 3915–3934.

Gerfen, C. R., Young, W. S., 1988. Distribution of striatonigral and striatopallidal peptidergic neurons in both patch and matrix compartments: an in situ hybridization histochemistry and fluorescent retrograde tracing study. *Brain Res* 460, 161–167.

Gertler, T. S., Chan, C. S., Surmeier, D. J., 2008. Dichotomous anatomical properties of adult striatal medium spiny neurons. *J Neurosci* 28, 10814–10824.

Gimnez-Amaya, J. M., McFarland, N. R., de las Heras, S., Haber, S. N., 1995. Organization of thalamic projections to the ventral striatum in the primate. *J Comp Neurol* 354, 127–149.

Goldman-Rakic, P. S., 1995. Cellular basis of working memory. *Neuron* 14, 477–485.

Gonon, F., 1997. Prolonged and extrasynaptic excitatory action of dopamine mediated by D1 receptors in the rat striatum in vivo. *J Neurosci* 17, 5972–5978.

Gorelova, N., Seamans, J. K., Yang, C. R., 2002. Mechanisms of dopamine activation of fast-spiking interneurons that exert inhibition in rat prefrontal cortex. *J Neurophysiol* 88, 3150–3166.

Gorny, J. H., Gorny, B., Wallace, D. G., Whishaw, I. Q., 2002. Fimbria-fornix lesions disrupt the dead reckoning (homing) component of exploratory behavior in mice. *Learn Mem* 9, 387–394.

Goto, Y., Grace, A. A., 2005. Dopaminergic modulation of limbic and cortical drive of nucleus accumbens in goal-directed behavior. *Nat Neurosci* 8, 805–812.

Goto, Y., O'Donnell, P., 2002. Timing-dependent limbic-motor synaptic integration in the nucleus accumbens. *Proc Natl Acad Sci U S A* 99, 13189–13193.

Goto, Y., Otani, S., Grace, A. A., 2007. The Yin and Yang of dopamine release: a new perspective. *Neuropharmacology* 53, 583–587.

Granata, A. R., Kitai, S. T., 1989. Intracellular analysis of excitatory subthalamic inputs to the pedunculopontine neurons. *Brain Res* 488, 57–72.

Greengard, P., Allen, P. B., Nairn, A. C., 1999. Beyond the dopamine receptor: the DARPP-32/protein phosphatase-1 cascade. *Neuron* 23, 435–447.

Grill, H. J., Kaplan, J. M., 2002. The neuroanatomical axis for control of energy balance. *Front Neuroendocrinol* 23, 2–40.

Grillner, S., Georgopoulos, A. P., Jordan, L. M., 1997. Selection and initiation of motor behavior. In: Stein, P. S. G., Grillner, S., Selverston, A. I., Stuart, D. G. (Eds.), *Neurons, Networks, and Motor Behavior.* MIT Press, Cambridge, MA, pp. 3–20.

Groenewegen, H. J., Berendse, H. W., Haber, S. N., 1993. Organization of the output of the ventral striatopallidal system in the rat: ventral pallidal efferents. *Neuroscience* 57, 113–122.

Groenewegen, H. J., der Zee, E. V.-V., te Kortschot, A., Witter, M. P., 1987. Organization of the projections from the subiculum to the ventral striatum in the rat. A study using anterograde transport of Phaseolus vulgaris leucoagglutinin. *Neuroscience* 23, 103–120.

Groenewegen, H. J., Galis-de Graaf, Y., Smeets, W. J., 1999a. Integration and segregation of limbic cortico-striatal loops at the thalamic level: an experimental tracing study in rats. *J Chem Neuroanat* 16, 167–185.

Groenewegen, H. J., Mulder, A. B., Beijer, A. V. J., Wright, C. I., Lopes Da Silva, F. H., Pennartz, C. M. A., 1999b. Hippocampal and amygdaloid interactions in the nucleus accumbens. *Psychobiology* 27, 149–164.

Groenewegen, H. J., Wright, C. I., Beijer, A. V., Voorn, P., 1999c. Convergence and segregation of ventral striatal inputs and outputs. *Ann N Y Acad Sci* 877, 49–63.

Gruber, A. J., Hussain, R. J., O'Donnell, P., 2009a. The nucleus accumbens: a switchboard for goal-directed behaviors. *PLoS One* 4, e5062.

Gruber, A. J., O'Donnell, P., 2009. Bursting activation of prefrontal cortex drives sustained up states in nucleus accumbens spiny neurons in vivo. *Synapse* 63, 173–180.

Gruber, A. J., Powell, E., O'Donnell, P., 2009b. Inhibition shapes responses of accumbens spiny neurons to spatiotemporal aspects of bursting cortical activation. *J Neurophysiol* 101, 1876–1882.

Gurney, K., Prescott, T. J., Redgrave, P., 2001a. A computational model of action selection in the basal ganglia I: A new functional anatomy. *Biol Cybern* 85, 401–410.

Gurney, K., Prescott, T. J., Redgrave, P., 2001b. A computational model of action selection in the basal ganglia II: Analysis and simulation of behaviour. *Biol Cybern* 85, 411–423.

Gurney, K. N., Humphries, M., Wood, R., Prescott, T. J., Redgrave, P., 2004. Testing computational hypotheses of brain systems function using high level models: a case study with the basal ganglia. *Network* 15, 263–290.

Guzman, J. N., Hernandez, A., Galarraga, E., Tapia, D., Laville, A., Vergara, R., Aceves, J., Vargas, J., 2003. Dopaminergic modulation of axon collaterals interconnecting spiny neurons of the rat striatum. *J Neurosci* 23, 8931–8940.

Haber, S. N., 2003. The primate basal ganglia: parallel and integrative networks. *J Chem Neuroanat* 26, 317–330.

Haber, S. N., Fudge, J. L., McFarland, N. R., 2000. Striatonigrostriatal pathways in primates form an ascending spiral from the shell to the dorsolateral striatum. *J Neurosci* 20, 2369–2382.

Hafting, T., Fyhn, M., Molden, S., Moser, M.-B., Moser, E. I., 2005. Microstructure of a spatial map in the entorhinal cortex. *Nature* 436, 801–806.

Hakan, R. L., Berg, G. I., Henriksen, S. J., 1992. Electrophysiological evidence for reciprocal connectivity between the nucleus accumbens septi and ventral pallidal region. *Brain Res* 581, 344–350.

Hammond, C., Bergman, H., Brown, P., 2007. Pathological synchronization in parkinson's disease: networks, models and treatments. *Trends Neurosci* 30, 357–364.

Hammond, C., Rouzair-Dubois, B., Feger, J., Jackson, A., Crossman, A. R., 1983. Anatomical and electrophysiological studies on the reciprocal projections between the subthalamic nucleus and nucleus tegmenti pedunculopontinus in the rat. *Neuroscience* 9, 41–52.

Hanley, J. J., Bolam, J. P., 1997. Synaptology of the nigrostriatal projection in relation to the compartmental organization of the neostriatum in the rat. *Neuroscience* 81, 353–370.

Hargreaves, E. L., Rao, G., Lee, I., Knierim, J. J., 2005. Major dissociation between medial and lateral entorhinal input to dorsal hippocampus. *Science* 308, 1792–1794.

Hazrati, L. N., Parent, A., 1992. Convergence of subthalamic and striatal efferents at pallidal level in primates: an anterograde-labeling study with biocytin and PHA-L. *Brain Research* 569, 336–340.

Heimer, L., Zahm, D. S., Churchill, L., Kalivas, P. W., Wohltmann, C., 1991. Specificity in the projection patterns of accumbal core and shell in the rat. *Neuroscience* 41, 89–125.

Heintz, N., 2001. BAC to the future: the use of bac transgenic mice for neuroscience research. *Nat Rev Neurosci* 2 (12), 861–870.

Hernandez-Echeagaray, E., Starling, A. J., Cepeda, C., Levine, M. S., 2004. Modulation of AMPA currents by D2 dopamine receptors in striatal medium-sized spiny neurons: are dendrites necessary? *Eur J Neurosci* 19, 2455–2463.

Hidaka, S., Totterdell, S., 2001. Ultrastructural features of the nitric oxide synthase-containing interneurons in the nucleus accumbens and their relationship with tyrosine hydroxylase-containing terminals. *J Comp Neurol* 431, 139–154.

Hilario, M. R. F., Costa, R. M., 2008. High on habits. *Front Neurosci* 2, 208–217.

Hok, V., Save, E., Lenck-Santini, P. P., Poucet, B., 2005. Coding for spatial goals in the prelimbic/infralimbic area of the rat frontal cortex. *Proc Natl Acad Sci U S A* 102, 4602–4607.

Holstege, G., 1998. The anatomy of the central control of posture: consistency

- and plasticity. *Neurosci Biobehav Rev* 22, 485–493.
- Hopf, F. W., Cascini, M. G., Gordon, A. S., Diamond, I., Bonci, A., 2003. Cooperative activation of dopamine D1 and D2 receptors increases spike firing of nucleus accumbens neurons via G-protein betagamma subunits. *J Neurosci* 23, 5079–5087.
- Howland, J. G., Taepavarapruk, P., Phillips, A. G., 2002. Glutamate receptor-dependent modulation of dopamine efflux in the nucleus accumbens by basolateral, but not central, nucleus of the amygdala in rats. *J Neurosci* 22, 1137–1145.
- Hsu, K. S., Huang, C. C., Yang, C. H., Gean, P. W., 1995. Presynaptic D2 dopaminergic receptors mediate inhibition of excitatory synaptic transmission in the rat neostriatum. *Brain Res* 690, 264–268.
- Humphries, M. D., 2002. The basal ganglia and action selection: a computational study at multiple levels of description. PhD Thesis, University of Sheffield.
- Humphries, M. D., Gurney, K. N., 2002. The role of intra-thalamic and thalamocortical circuits in action selection. *Network* 13, 131–156.
- Humphries, M. D., Stewart, R. D., Gurney, K. N., 2006. A physiologically plausible model of action selection and oscillatory activity in the basal ganglia. *J Neurosci* 26, 12921–12942.
- Humphries, M. D., Wood, R., Gurney, K., 2009. Dopamine-modulated dynamic cell assemblies generated by the GABAergic striatal microcircuit. *Neural Networks* 22, 1174–1188.
- Hussain, Z., Johnson, L. R., Totterdell, S., 1996. A light and electron microscopic study of NADPH-diaphorase-, calretinin- and parvalbumin-containing neurons in the rat nucleus accumbens. *J Chem Neuroanat* 10, 19–39.
- Ikemoto, S., 2007. Dopamine reward circuitry: two projection systems from the ventral midbrain to the nucleus accumbens-olfactory tubercle complex. *Brain Res Rev* 56, 27–78.
- Inglis, W. L., Dunbar, J. S., Winn, P., 1994. Outflow from the nucleus accumbens to the pedunculopontine tegmental nucleus: a dissociation between locomotor activity and the acquisition of responding for conditioned reinforcement stimulated by d-amphetamine. *Neuroscience* 62, 51–64.
- Ishikawa, A., Ambroggi, F., Nicola, S. M., Fields, H. L., 2008. Dorsomedial prefrontal cortex contribution to behavioral and nucleus accumbens neuronal responses to incentive cues. *J Neurosci* 28, 5088–5098.
- Jenkinson, N., Nandi, D., Aziz, T. Z., Stein, J. F., 2005. Pedunculopontine nucleus: a new target for deep brain stimulation for akinesia. *Neuroreport* 16, 1875–1876.
- Joel, D., Niv, Y., Ruppel, E., 2002. Actor-critic models of the basal ganglia: new anatomical and computational perspectives. *Neural Netw* 15, 535–547.
- Joel, D., Weiner, I., 2000a. The connections of the dopaminergic system with the striatum in rats and primates: an analysis with respect to the functional and compartmental organization of the striatum. *Neuroscience* 96, 451–474.
- Joel, D., Weiner, I., 2000b. Striatal contention scheduling and the split circuit scheme of basal ganglia-thalamocortical circuitry: from anatomy to behaviour. In: Miller, R., Wickens, J. R. (Eds.), *Brain Dynamics and the Striatal Complex*. Harwood Academic Publishers, Australia, pp. 209–236.
- Jongen-Relo, A. L., Voorn, P., Groenewegen, H. J., 1994. Immunohistochemical characterization of the shell and core territories of the nucleus accumbens in the rat. *Eur J Neurosci* 6, 1255–1264.
- Kalivas, P. W., Jackson, D., Romanides, A., Wyndham, L., Duffy, P., 2001. Involvement of pallidothalamic circuitry in working memory. *Neuroscience* 104, 129–136.
- Kang, Y., Kitai, S. T., 1990. Electrophysiological properties of pedunculopontine neurons and their postsynaptic responses following stimulation of substantia nigra reticulata. *Brain Res* 535, 79–95.
- Kawaguchi, Y., Wilson, C. J., Augood, S. J., Emson, P. C., 1995. Striatal interneurons: chemical, physiological and morphological characterization. *Trends Neurosci* 18, 527–535.
- Kawaguchi, Y., Wilson, C. J., Emson, P. C., 1990. Projection subtypes of rat neostriatal matrix cells revealed by intracellular injection of biocytin. *J Neurosci* 10, 3421–3438.
- Kelley, A. E., 1999. Neural integrative activities of nucleus accumbens subregions in relation to learning and motivation. *Psychobiology* 27, 198–213.
- Kelley, A. E., Baldo, B. A., Pratt, W. E., Will, M. J., 2005. Corticostriatal-hypothalamic circuitry and food motivation: integration of energy, action and reward. *Physiol Behav* 86, 773–795.
- Kelley, A. E., Domesick, V. B., 1982. The distribution of the projection from the hippocampal formation to the nucleus accumbens in the rat: an anterograde- and retrograde-horseradish peroxidase study. *Neuroscience* 7, 2321–2335.
- Khamassi, M., Lacheze, L., Girard, B., Berthoz, A., Guillot, A., 2005. Actor-critic models of reinforcement learning in the basal ganglia: from natural to artificial rats. *Adaptive Behavior* 13, 131–148.
- Khamassi, M., Mulder, A. B., Tabuchi, E., Douchamps, V., Wiener, S. I., 2008. Anticipatory reward signals in ventral striatal neurons of behaving rats. *Eur J Neurosci* 28, 1849–1866.
- Kita, H., Kosaka, T., Heizmann, C. W., 1990. Parvalbumin-immunoreactive neurons in the rat neostriatum: a light and electron microscopic study. *Brain Res* 536, 1–15.
- Kitai, S. T., Shepard, P. D., Callaway, J. C., Scroggs, R., 1999. Afferent modulation of dopamine neuron firing patterns. *Curr Opin Neurobiol* 9, 690–697.
- Kiyatkin, E. A., 2002. Dopamine in the nucleus accumbens: cellular actions, drug- and behavior-associated fluctuations, and a possible role in an organism's adaptive activity. *Behav Brain Res* 137, 27–46.
- Knierim, J. J., 2006. Neural representations of location outside the hippocampus. *Learn Mem* 13, 405–415.
- Kubota, Y., Kawaguchi, Y., 1993. Spatial distributions of chemically identified intrinsic neurons in relation to patch and matrix compartments of rat neostriatum. *J Comp Neurol* 332, 499–513.
- Kubota, Y., Kawaguchi, Y., 2000. Dependence of GABAergic synaptic areas on the interneuron type and target size. *J Neurosci* 20, 375–386.
- Lammel, S., Hetzel, A., Hckel, O., Jones, I., Liss, B., Roeper, J., 2008. Unique properties of mesoprefrontal neurons within a dual mesocortico-imbic dopamine system. *Neuron* 57, 760–773.
- Lanciego, J. L., Gonzalo, N., Castle, M., Sanchez-Escobar, C., Aymerich, M. S., Obeso, J. A., 2004. Thalamic innervation of striatal and subthalamic neurons projecting to the rat entopeduncular nucleus. *Eur J Neurosci* 19, 1267–1277.
- Lau, B., Glimcher, P. W., 2007. Action and outcome encoding in the primate caudate nucleus. *J Neurosci* 27, 14502–14514.
- Lavin, A., Grace, A. A., 1994. Modulation of dorsal thalamic cell activity by the ventral pallidum: its role in the regulation of thalamocortical activity by the basal ganglia. *Synapse* 18, 104–127.
- Lavin, A., Grace, A. A., 1996. Physiological properties of rat ventral pallidal neurons recorded intracellularly in vivo. *J Neurophysiol* 75, 1432–1443.
- Leblois, A., Boraud, T., Meissner, W., Bergman, H., Hansel, D., 2006. Competition between feedback loops underlies normal and pathological dynamics in the basal ganglia. *J Neurosci* 26, 3567–3583.
- LeDoux, J. E., 2000. Emotion circuits in the brain. *Annu Rev Neurosci* 23, 155–184.
- Lee, A. K., Wilson, M. A., 2002. Memory of sequential experience in the hippocampus during slow wave sleep. *Neuron* 36, 1183–1194.
- Levant, B., 1997. The D3 dopamine receptor: neurobiology and potential clinical relevance. *Pharmacol Rev* 49, 231–252.
- Levant, B., 1998. Differential distribution of d3 dopamine receptors in the brains of several mammalian species. *Brain Res* 800, 269–274.
- Lindskog, M., Kim, M., Wikström, M. A., Blackwell, K. T., Kotaleski, J. H., 2006. Transient calcium and dopamine increase PKA activity and DARPP-32 phosphorylation. *PLoS Comput Biol* 2, e119.
- Lowe, R., Humphries, M., Ziemke, T., 2009. The dual-route hypothesis: Evaluating a neurocomputational model of fear conditioning in rats. *Connection Science* 21, 15–37.
- Lu, X. Y., Ghasemzadeh, M. B., Kalivas, P. W., 1998. Expression of D1 receptor, D2 receptor, substance P and enkephalin messenger RNAs in the neurons projecting from the nucleus accumbens. *Neuroscience* 82, 767–780.
- Magill, P. J., Bolam, J. P., Bevan, M. D., 2001. Dopamine regulates the impact of the cerebral cortex on the subthalamic nucleus-globus pallidus network. *Neuroscience* 106, 313–330.
- Mahon, S., Deniau, J. M., Charpier, S., 2001. Relationship between EEG potentials and intracellular activity of striatal and cortico-striatal neurons: an in vivo study under different anesthetics. *Cereb Cortex* 11, 360–373.
- Malenka, R. C., Bear, M. F., 2004. LTP and LTD: an embarrassment of riches. *Neuron* 44, 5–21.
- Margolis, E. B., Mitchell, J. M., Ishikawa, J., Hjelmstad, G. O., Fields, H. L., 2008. Midbrain dopamine neurons: projection target determines action potential duration and dopamine D(2) receptor inhibition. *J Neurosci* 28, 8908–8913.
- Matamales, M., Bertran-Gonzalez, J., Salomon, L., Degos, B., Deniau, J.-M., Valjent, E., Hervé, D., Girault, J.-A., 2009. Striatal medium-sized spiny neurons: identification by nuclear staining and study of neuronal subpopulations

in BAC transgenic mice. *PLoS One* 4, e4770.

Matsumoto, N., Minamimoto, T., Graybiel, A. M., Kimura, M., 2001. Neurons in the thalamic CM-Pf complex supply striatal neurons with information about behaviorally significant sensory events. *J Neurophysiol* 85, 960–976.

Maurice, N., Deniau, J. M., Glowinski, J., Thierry, A. M., 1998. Relationships between the prefrontal cortex and the basal ganglia in the rat: physiology of the corticosubthalamic circuits. *J Neurosci* 18, 9539–9546.

Maurice, N., Deniau, J. M., Glowinski, J., Thierry, A. M., 1999. Relationships between the prefrontal cortex and the basal ganglia in the rat: physiology of the cortico-nigral circuits. *J Neurosci* 19, 4674–4681.

Maurice, N., Deniau, J. M., Menetrey, A., Glowinski, J., Thierry, A. M., 1997. Position of the ventral pallidum in the rat prefrontal cortex-basal ganglia circuit. *Neuroscience* 80, 523–534.

Maurice, N., Mercer, J., Chan, C. S., Hernandez-Lopez, S., Held, J., Tkatch, T., Surmeier, D. J., 2004. D2 dopamine receptor-mediated modulation of voltage-dependent Na<sup>+</sup> channels reduces autonomous activity in striatal cholinergic interneurons. *J Neurosci* 24, 10289–10301.

Maurin, Y., Banrezes, B., Menetrey, A., Mailly, P., Deniau, J. M., 1999. Three-dimensional distribution of nigrostriatal neurons in the rat: relation to the topography of striatonigral projections. *Neuroscience* 91, 891–909.

McClure, S. M., Daw, N. D., Montague, P. R., 2003. A computational substrate for incentive salience. *Trends Neurosci* 26, 423–428.

McDonald, A. J., 1991. Topographical organization of amygdaloid projections to the caudatoputamen, nucleus accumbens, and related striatal-like areas of the rat brain. *Neuroscience* 44, 15–33.

McDonald, A. J., 1998. Cortical pathways to the mammalian amygdala. *Prog Neurobiol* 55, 257–332.

McGeorge, A. J., Faull, R. L., 1989. The organization of the projection from the cerebral cortex to the striatum in the rat. *Neuroscience* 29, 503–537.

McGinty, V. B., Grace, A. A., 2009a. Activity-dependent depression of medial prefrontal cortex inputs to accumbens neurons by the basolateral amygdala. *Neuroscience* 162, 1429–1436.

McGinty, V. B., Grace, A. A., 2009b. Timing-dependent regulation of evoked spiking in nucleus accumbens neurons by integration of limbic and prefrontal cortical inputs. *J Neurophysiol* 101, 1823–1835.

McHaffie, J. G., Stanford, T. R., Stein, B. E., Coizet, V., Redgrave, P., 2005. Subcortical loops through the basal ganglia. *Trends Neurosci* 28, 401–407.

McNaughton, B. L., Battaglia, F. P., Jensen, O., Moser, E. I., Moser, M.-B., 2006. Path integration and the neural basis of the ‘cognitive map’. *Nat Rev Neurosci* 7, 663–678.

Mena-Segovia, J., Bolam, J. P., Magill, P. J., 2004. Pedunculopontine nucleus and basal ganglia: distant relatives or part of the same family? *Trends Neurosci* 27, 585–588.

Mengual, E., de las Heras, S., Erro, E., Lanciego, J. L., Gimenez-Amaya, J. M., 1999. Thalamic interaction between the input and the output systems of the basal ganglia. *J Chem Neuroanat* 16, 187–200.

Meredith, G., Baldo, B., Andrezjewski, M., Kelley, A., 2008. The structural basis for mapping behavior onto the ventral striatum and its subdivisions. *Brain Struct Funct* 213, 17–27.

Meredith, G. E., Agolia, R., Arts, M. P., Groenewegen, H. J., Zahm, D. S., 1992. Morphological differences between projection neurons of the core and shell in the nucleus accumbens of the rat. *Neuroscience* 50, 149–162.

Meredith, G. E., Blank, B., Groenewegen, H. J., 1989. The distribution and compartmental organization of the cholinergic neurons in nucleus accumbens of the rat. *Neuroscience* 31, 327–345.

Middleton, F. A., Strick, P. L., 2000. Basal ganglia and cerebellar loops: motor and cognitive circuits. *Brain Res Brain Res Rev* 31, 236–250.

Miller, E. K., 2000. The prefrontal cortex and cognitive control. *Nat Rev Neurosci* 1, 59–65.

Mink, J. W., 1996. The basal ganglia: Focused selection and inhibition of competing motor programs. *Prog Neurobiol* 50, 381–425.

Missale, C., Nash, S. R., Robinson, S. W., Jaber, M., Caron, M. G., 1998. Dopamine receptors: from structure to function. *Physiological Review* 78, 189–225.

Miyamoto, Y., Jinnai, K., 1994. The inhibitory input from the substantia nigra to the mediodorsal nucleus neurons projecting to the prefrontal cortex in the cat. *Brain Res* 649, 313–318.

Mizumori, S. J. Y., Yeshenko, O., Gill, K. M., Davis, D. M., 2004. Parallel processing across neural systems: implications for a multiple memory system hypothesis. *Neurobiol Learn Mem* 82, 278–298.

Mizuno, T., Schmauss, C., Rayport, S., 2007. Distinct roles of presynaptic dopamine receptors in the differential modulation of the intrinsic synapses of medium-spiny neurons in the nucleus accumbens. *BMC Neurosci* 8.

Mogenson, G. J., Jones, D. L., Yim, C. Y., 1980. From motivation to action: functional interface between the limbic system and the motor system. *Prog Neurobiol* 14, 69–97.

Mogenson, G. J., Swanson, L. W., Wu, M., 1983. Neural projections from nucleus accumbens to globus pallidus, substantia innominata, and lateral preoptic-lateral hypothalamic area: an anatomical and electrophysiological investigation in the rat. *J Neurosci* 3, 189–202.

Mogenson, G. J., Swanson, L. W., Wu, M., 1985. Evidence that projections from substantia innominata to zona incerta and mesencephalic locomotor region contribute to locomotor activity. *Brain Res* 334, 65–76.

Moine, C. L., Bloch, B., 1996. Expression of the D3 dopamine receptor in peptidergic neurons of the nucleus accumbens: comparison with the D1 and D2 dopamine receptors. *Neuroscience* 73, 131–143.

Montague, P. R., Hyman, S. E., Cohen, J. D., 2004a. Computational roles for dopamine in behavioural control. *Nature* 431, 760–767.

Montague, P. R., McClure, S. M., Baldwin, P. R., Phillips, P. E., Budygin, E. A., Stuber, G. D., Kilpatrick, M. R., Wightman, R. M., 2004b. Dynamic gain control of dopamine delivery in freely moving animals. *J Neurosci* 24, 1754–1759.

Montaran, M. F., Deniau, J. M., Menetrey, A., Glowinski, J., Thierry, A. M., 1996. Prefrontal cortex inputs of the nucleus accumbens-nigro-thalamic circuit. *Neuroscience* 71, 371–382.

Morris, R. G. M., 2006. Elements of a neurobiological theory of hippocampal function: the role of synaptic plasticity, synaptic tagging and schemas. *Eur J Neurosci* 23, 2829–2846.

Moyer, J. T., Wolf, J. A., Finkel, L. H., 2007. Effects of dopaminergic modulation on the integrative properties of the ventral striatal medium spiny neuron. *J Neurophysiol* 98, 3731–3748.

Mrzljak, L., Bergson, C., Pappy, M., Huff, R., Levenson, R., Goldman-Rakic, P. S., 1996. Localization of dopamine D4 receptors in GABAergic neurons of the primate brain. *Nature* 381, 245–248.

Mulder, A. B., Hodenprijl, M. G., Lopes da Silva, F. H., 1998. Electrophysiology of the hippocampal and amygdaloid projections to the nucleus accumbens of the rat: convergence, segregation, and interaction of inputs. *J Neurosci* 18, 5095–5102.

Mulder, A. B., Shibata, R., Trullier, O., Wiener, S. I., 2005. Spatially selective reward site responses in tonically active neurons of the nucleus accumbens in behaving rats. *Exp Brain Res* 163, 32–43.

Mulder, A. B., Tabuchi, E., Wiener, S. I., 2004. Neurons in hippocampal afferent zones of rat striatum parse routes into multi-patch segments during maze navigation. *Eur J Neurosci* 19, 1923–1932.

Munro-Davies, L. E., Winter, J., Aziz, T. Z., Stein, J. F., 1999. The role of the pedunculopontine region in basal-ganglia mechanisms of akinesia. *Exp Brain Res* 129, 511–517.

Mura, A., Feldon, J., 2003. Spatial learning in rats is impaired after degeneration of the nigrostriatal dopaminergic system. *Mov Disord* 18, 860–871.

Nair-Roberts, R. G., Chatelain-Badie, S. D., Benson, E., White-Cooper, H., Bolam, J. P., Ungless, M. A., 2008. Stereological estimates of dopaminergic, GABAergic and glutamatergic neurons in the ventral tegmental area, substantia nigra and retrorubral field in the rat. *Neuroscience* 152, 1024–1031.

Nicola, S. M., 2007. The nucleus accumbens as part of a basal ganglia action selection circuit. *Psychopharmacology (Berl)* 191, 521–550.

Nicola, S. M., Malenka, R. C., 1998. Modulation of synaptic transmission by dopamine and norepinephrine in ventral but not dorsal striatum. *J Neurophysiol* 79, 1768–1776.

Nicola, S. M., Surmeier, J., Malenka, R. C., 2000. Dopaminergic modulation of neuronal excitability in the striatum and nucleus accumbens. *Ann Rev Neurosci* 23, 185–215.

Niv, Y., Daw, N., Joel, D., Dayan, P., 2006. Tonic dopamine: opportunity costs and the control of response vigor. *Psychopharmacology (Berl)* 191, 507–520.

Noan, D., Avale, M. E., Wedemeyer, C., Calvo, D., Peper, M., Rubinstein, M., 2006. Identification of brain neurons expressing the dopamine D4 receptor gene using BAC transgenic mice. *Eur J Neurosci* 24, 2429–2438.

Oakman, S. A., Faris, P. L., Kerr, P. E., Cozzari, C., Hartman, B. K., 1995. Distribution of pontomesencephalic cholinergic neurons projecting to substantia nigra differs significantly from those projecting to ventral tegmental area. *J Neurosci* 15, 5859–5869.

O’Donnell, P., Grace, A. A., 1995. Synaptic interactions among excitatory af-

- ferents to nucleus accumbens neurons: hippocampal gating of prefrontal cortical input. *J Neurosci* 15, 3622–3639.
- O'Keefe, J., 1999. Do hippocampal pyramidal cells signal non-spatial as well as spatial information? *Hippocampus* 9, 352–364.
- O'Keefe, J., Burgess, N., 2005. Dual phase and rate coding in hippocampal place cells: theoretical significance and relationship to entorhinal grid cells. *Hippocampus* 15, 853–866.
- O'Keefe, J., Conway, D. H., 1978. Hippocampal place units in the freely moving rat: why they fire where they fire. *Exp Brain Res* 31, 573–590.
- O'Keefe, J., Dostrovsky, J., 1971. The hippocampus as a spatial map. Preliminary evidence from unit activity in the freely-moving rat. *Brain Res* 34, 171–175.
- Olmos, J. S. D., Beltramino, C. A., Alheid, G., 2004. Amygdala and extended amygdala of the rat: A cytoarchitectural, fibroarchitectural, and chemoarchitectural survey. In: Paxinos, G. (Ed.), *The Rat Nervous System*, Third Edition. Academic Press, San Diego, CA, pp. 509–603.
- O'Mara, S., 2006. Controlling hippocampal output: the central role of subiculum in hippocampal information processing. *Behav Brain Res* 174, 304–312.
- Oorschot, D. E., 1996. Total number of neurons in the neostriatal, pallidal, subthalamic, and substantia nigral nuclei of the rat basal ganglia: a stereological study using the cavalieri and optical disector methods. *J Comp Neurol* 366, 580–599.
- Pahapill, P. A., Lozano, A. M., 2000. The pedunculopontine nucleus and Parkinson's disease. *Brain* 123 ( Pt 9), 1767–1783.
- Pan, W. X., Hyland, B. I., 2005. Pedunculopontine tegmental nucleus controls conditioned responses of midbrain dopamine neurons in behaving rats. *J Neurosci* 25, 4725–4732.
- Par, D., Quirk, G. J., Ledoux, J. E., 2004. New vistas on amygdala networks in conditioned fear. *J Neurophysiol* 92, 1–9.
- Parent, A., Hazrati, L. N., 1995. Functional anatomy of the basal ganglia. II. The place of subthalamic nucleus and external pallidum in basal ganglia circuitry. *Brain Res Brain Res Rev* 20, 128–154.
- Pastalkova, E., Itskov, V., Amarasingham, A., Buzsáki, G., 2008. Internally generated cell assembly sequences in the rat hippocampus. *Science* 321, 1322–1327.
- Paxinos, G., Watson, C., 1998. *The Rat Brain In Stereotaxic Coordinates*, 4th Edition. Academic Press, San Diego, CA.
- Pennartz, C. M., 1995. The ascending neuromodulatory systems in learning by reinforcement: comparing computational conjectures with experimental findings. *Brain Res Brain Res Rev* 21, 219–245.
- Pennartz, C. M., der Weel, M. J. D.-V., Kitai, S. T., da Silva, F. H. L., 1992. Presynaptic dopamine D1 receptors attenuate excitatory and inhibitory limbic inputs to the shell region of the rat nucleus accumbens studied in vitro. *J Neurophysiol* 67, 1325–1334.
- Pennartz, C. M., Groenewegen, H. J., da Silva, F. H. L., 1994. The nucleus accumbens as a complex of functionally distinct neuronal ensembles: an integration of behavioural, electrophysiological and anatomical data. *Prog Neurobiol* 42, 719–761.
- Pennartz, C. M. A., Lee, E., Verheul, J., Lipa, P., Barnes, C. A., McNaughton, B. L., 2004. The ventral striatum in off-line processing: ensemble reactivation during sleep and modulation by hippocampal ripples. *J Neurosci* 24, 6446–6456.
- Peoples, L. L., Gee, F., Bibi, R., West, M. O., 1998. Phasic firing time locked to cocaine self-infusion and locomotion: dissociable firing patterns of single nucleus accumbens neurons in the rat. *J Neurosci* 18, 7588–7598.
- Peters, J., LaLumiere, R. T., Kalivas, P. W., 2008. Infralimbic prefrontal cortex is responsible for inhibiting cocaine seeking in extinguished rats. *J Neurosci* 28 (23), 6046–6053.
- Peyrache, A., Khamassi, M., Benchenane, K., Wiener, S. I., Battaglia, F. P., 2009. Replay of rule-learning related neural patterns in the prefrontal cortex during sleep. *Nat Neurosci* 12, 916–926.
- Phillips, P. E. M., Stuber, G. D., Heien, M. L. A. V., Wightman, R. M., Carelli, R. M., 2003. Subsecond dopamine release promotes cocaine seeking. *Nature* 422, 614–618.
- Pisani, A., Bonsi, P., Centonze, D., Calabresi, P., Bernardi, G., 2000. Activation of D2-like dopamine receptors reduces synaptic inputs to striatal cholinergic interneurons. *J Neurosci* 20, RC69.
- Pitkanen, A., Savander, V., LeDoux, J. E., 1997. Organization of intra-amygdaloid circuitries in the rat: an emerging framework for understanding functions of the amygdala. *Trends Neurosci* 20, 517–523.
- Ploeger, G. E., Spruijt, B. M., Cools, A. R., 1994. Spatial localization in the Morris water maze in rats: acquisition is affected by intra-accumbens injections of the dopaminergic antagonist haloperidol. *Behav Neurosci* 108, 927–934.
- Prescott, T. J., Montes Gonzalez, F. M., Gurney, K., Humphries, M. D., Redgrave, P., 2006. A robot model of the basal ganglia: Behavior and intrinsic processing. *Neural Netw* 19, 31–61.
- Ragozzino, M. E., Detrick, S., Kesner, R. P., 1999. Involvement of the prelimbic-infralimbic areas of the rodent prefrontal cortex in behavioral flexibility for place and response learning. *J Neurosci* 19, 4585–4594.
- Redgrave, P., Gurney, K., 2006. The short-latency dopamine signal: a role in discovering novel actions? *Nat Rev Neurosci* 7, 967–975.
- Redgrave, P., Gurney, K., Reynolds, J., 2008. What is reinforced by phasic dopamine signals? *Brain Res Rev* 58, 322–339.
- Redgrave, P., Prescott, T. J., Gurney, K., 1999a. The basal ganglia: A vertebrate solution to the selection problem? *Neuroscience* 89, 1009–1023.
- Redgrave, P., Prescott, T. J., Gurney, K., 1999b. Is the short-latency dopamine response too short to signal reward error? *Trends Neurosci* 22, 146–151.
- Redish, A. D., Touretzky, D. S., 1997. Cognitive maps beyond the hippocampus. *Hippocampus* 7, 15–35.
- Reynolds, J. N., Wickens, J. R., 2002. Dopamine-dependent plasticity of corticostriatal synapses. *Neural Netw* 15, 507–521.
- Rich, E. L., Shapiro, M. L., 2007. Prelimbic/infralimbic inactivation impairs memory for multiple task switches, but not flexible selection of familiar tasks. *J Neurosci* 27, 4747–4755.
- Richfield, E. K., Penney, J. B., Young, A. B., 1989. Anatomical and affinity state comparisons between dopamine D1 and D2 receptors in the rat central nervous system. *Neuroscience* 30, 767–777.
- Richtand, N. M., Kelsoe, J. R., Segal, D. S., Kuczenski, R., 1995. Regional quantification of D1, D2, and D3 dopamine receptor mRNA in rat brain using a ribonuclease protection assay. *Brain Res Mol Brain Res* 33, 97–103.
- Rivera, A., Alberti, I., Martn, A. B., Narvez, J. A., de la Calle, A., Moratalla, R., 2002. Molecular phenotype of rat striatal neurons expressing the dopamine D5 receptor subtype. *Eur J Neurosci* 16, 2049–2058.
- Roesch, M. R., Calu, D. J., Schoenbaum, G., 2007. Dopamine neurons encode the better option in rats deciding between differently delayed or sized rewards. *Nat Neurosci* 10, 1615–1624.
- Rolls, E. T., Stringer, S. M., Elliot, T., 2006. Entorhinal cortex grid cells can map to hippocampal place cells by competitive learning. *Network* 17, 447–465.
- Romanelli, P., Esposito, V., Schaal, D. W., Heit, G., 2005. Somatotopy in the basal ganglia: experimental and clinical evidence for segregated sensorimotor channels. *Brain Res Brain Res Rev* 48, 112–128.
- Sadek, A. R., Magill, P. J., Bolam, J. P., 2007. A single-cell analysis of intrinsic connectivity in the rat globus pallidus. *J Neurosci* 27, 6352–6362.
- Salamone, J. D., Correa, M., Farrar, A., Mingote, S. M., 2007. Effort-related functions of nucleus accumbens dopamine and associated forebrain circuits. *Psychopharmacology (Berl)* 191, 461–482.
- Samejima, K., Ueda, Y., Doya, K., Kimura, M., 2005. Representation of action-specific reward values in the striatum. *Science* 310, 1337–1340.
- Samsonovich, A., McNaughton, B. L., 1997. Path integration and cognitive mapping in a continuous attractor neural network model. *J Neurosci* 17, 5900–5920.
- Sargolini, F., Florian, C., Oliverio, A., Mele, A., Roullet, P., 2003. Differential involvement of NMDA and AMPA receptors within the nucleus accumbens in consolidation of information necessary for place navigation and guidance strategy of mice. *Learn Mem* 10, 285–292.
- Sargolini, F., Fyhn, M., Hafting, T., McNaughton, B. L., Witter, M. P., Moser, M.-B., Moser, E. I., 2006. Conjunctive representation of position, direction, and velocity in entorhinal cortex. *Science* 312, 758–762.
- Scarnati, E., Campana, E., Pacitti, C., 1983. The functional role of the nucleus accumbens in the control of the substantia nigra: electrophysiological investigations in intact and striatum-globus pallidus lesioned rats. *Brain Res* 265, 249–257.
- Schmitzer-Torbert, N. C., Redish, A. D., 2008. Task-dependent encoding of space and events by striatal neurons is dependent on neural subtype. *Neuroscience* 153, 349–360.
- Schoenbaum, G., Setlow, B., Ramus, S. J., 2003. A systems approach to orbitofrontal cortex function: recordings in rat orbitofrontal cortex reveal interactions with different learning systems. *Behav Brain Res* 146, 19–29.
- Schultz, W., 2007. Behavioral dopamine signals. *Trends Neurosci* 30, 203–210.
- Schultz, W., Dayan, P., Montague, P. R., 1997. A neural substrate of prediction

- and reward. *Science* 275, 1593–1599.
- Schultz, W., Tremblay, L., Hollerman, J. R., 2000. Reward processing in primate orbitofrontal cortex and basal ganglia. *Cereb Cortex* 10, 272–284.
- Schwartz, J. C., Diaz, J., Bordet, R., Griffon, N., Perachon, S., Pilon, C., Ridray, S., Sokoloff, P., 1998. Functional implications of multiple dopamine receptor subtypes: the D1/D3 receptor coexistence. *Brain Res Rev* 26, 236–242.
- Setlow, B., McGaugh, J. L., 1998. Sulpiride infused into the nucleus accumbens posttraining impairs memory of spatial water maze training. *Behav Neurosci* 112, 603–610.
- Setlow, B., Schoenbaum, G., Gallagher, M., 2003. Neural encoding in ventral striatum during olfactory discrimination learning. *Neuron* 38, 625–636.
- Sharp, P. E., 2006. Subicular place cells generate the same “map” for different environments: comparison with hippocampal cells. *Behav Brain Res* 174, 206–214.
- Shen, W., Flajolet, M., Greengard, P., Surmeier, D. J., 2008. Dichotomous dopaminergic control of striatal synaptic plasticity. *Science* 321, 848–851.
- Shibata, R., Mulder, A. B., Trullier, O., Wiener, S. I., 2001. Position sensitivity in phasically discharging nucleus accumbens neurons of rats alternating between tasks requiring complementary types of spatial cues. *Neuroscience* 108, 391–411.
- Sinnamon, H. M., 1993. Preoptic and hypothalamic neurons and the initiation of locomotion in the anesthetized rat. *Prog Neurobiol* 41, 323–344.
- Smith, D. M., Mizumori, S. J. Y., 2006a. Hippocampal place cells, context, and episodic memory. *Hippocampus* 16, 716–729.
- Smith, D. M., Mizumori, S. J. Y., 2006b. Learning-related development of context-specific neuronal responses to places and events: the hippocampal role in context processing. *J Neurosci* 26, 3154–3163.
- Smith, Y., Kieval, J. Z., 2000. Anatomy of the dopamine system in the basal ganglia. *Trends Neurosci* 23, S28–33.
- Smith, Y., Raju, D. V., Pare, J. F., Sidibe, M., 2004. The thalamostriatal system: a highly specific network of the basal ganglia circuitry. *Trends Neurosci* 27, 520–527.
- Somers, L. A., Beyene, M., Carelli, R. M., Wightman, R. M., 2009. Synaptic overflow of dopamine in the nucleus accumbens arises from neuronal activity in the ventral tegmental area. *J Neurosci* 29, 1735–1742.
- Stanton, G. B., Goldberg, M. E., Bruce, C. J., 1988. Frontal eye field efferents in the macaque monkey: I. subcortical pathways and topography of striatal and thalamic terminal fields. *J Comp Neurol* 271, 473–492.
- Surmeier, D. J., Ding, J., Day, M., Wang, Z., Shen, W., 2007. D1 and D2 dopamine-receptor modulation of striatal glutamatergic signaling in striatal medium spiny neurons. *Trends Neurosci* 30, 228–235.
- Surmeier, D. J., Eberwine, J., Wilson, C. J., Cao, Y., Stefani, A., Kitai, S. T., 1992. Dopamine receptor subtypes colocalize in rat striatonigral neurons. *Proc Natl Acad Sci USA* 89, 10178–10182.
- Surmeier, D. J., Song, W. J., Yan, Z., 1996. Coordinated expression of dopamine receptors in neostriatal medium spiny neurons. *J Neurosci* 16, 6579–6591.
- Swanson, L. W., 2000. Cerebral hemisphere regulation of motivated behavior. *Brain Res* 886, 113–164.
- Swanson, L. W., Cowan, W. M., 1977. An autoradiographic study of the organization of the efferent connections of the hippocampal formation in the rat. *J Comp Neurol* 172, 49–84.
- Swerdlow, N. R., Koob, G. F., 1987. Lesions of the dorsomedial nucleus of the thalamus, medial prefrontal cortex and pedunculo-pontine nucleus: effects on locomotor activity mediated by nucleus accumbens-ventral pallidal circuitry. *Brain Res* 412, 233–243.
- Taha, S. A., Nicola, S. M., Fields, H. L., 2007. Cue-evoked encoding of movement planning and execution in the rat nucleus accumbens. *J Physiol* 584, 801–818.
- Taverna, S., Canciani, B., Pennartz, C. M. A., 2005. Dopamine D1-receptors modulate lateral inhibition between principal cells of the nucleus accumbens. *J Neurophysiol* 93, 1816–1819.
- Taverna, S., van Dongen, Y. C., Groenewegen, H. J., Pennartz, C. M., 2004. Direct physiological evidence for synaptic connectivity between medium-sized spiny neurons in rat nucleus accumbens in situ. *J Neurophysiol* 91, 1111–1121.
- Tecuapetla, F., Carrillo-Reid, L., Vargas, J., Galarraga, E., 2007. Dopaminergic modulation of short-term synaptic plasticity at striatal inhibitory synapses. *Proc Natl Acad Sci U S A* 104, 10258–10263.
- Tepper, J. M., Bolam, J. P., 2004. Functional diversity and specificity of neostriatal interneurons. *Curr Opin Neurobiol* 14, 685–692.
- Thompson, L. T., Best, P. J., 1990. Long-term stability of the place-field activity of single units recorded from the dorsal hippocampus of freely behaving rats. *Brain Res* 509, 299–308.
- Tolman, E. C., 1948. Cognitive maps in rats and men. *The Psychological Review* 55, 189–208.
- Totterdell, S., Meredith, G. E., 1997. Topographical organization of projections from the entorhinal cortex to the striatum of the rat. *Neuroscience* 78, 715–729.
- Trullier, O., Shibata, R., Mulder, A. B., Wiener, S. I., 1999. Hippocampal neuronal position selectivity remains fixed to room cues only in rats alternating between place navigation and beacon approach tasks. *Eur J Neurosci* 11, 4381–4388.
- Usuda, I., Tanaka, K., Chiba, T., 1998. Efferent projections of the nucleus accumbens in the rat with special reference to subdivision of the nucleus: biotinylated dextran amine study. *Brain Res* 797, 73–93.
- Uylings, H. B. M., Groenewegen, H. J., Kolb, B., 2003. Do rats have a prefrontal cortex? *Behav Brain Res* 146, 3–17.
- van der Meer, M. A. A., Redish, A. D., 2009. Covert expectation-of-reward in rat ventral striatum at decision points. *Front Integr Neurosci* 3, 1.
- van Dongen, Y. C., Deniau, J.-M., Pennartz, C. M. A., de Graaf, Y. G., Voorn, P., Thierry, A.-M., Groenewegen, H. J., 2005. Anatomical evidence for direct connections between the shell and core subregions of the rat nucleus accumbens. *Neuroscience* 136, 1049–1071.
- van Groen, T., Wyss, J. M., 1990. Extrinsic projections from area CA1 of the rat hippocampus: olfactory, cortical, subcortical, and bilateral hippocampal formation projections. *J Comp Neurol* 302, 515–528.
- Venton, B. J., Zhang, H., Garris, P. A., Phillips, P. E., Sulzer, D., Wightman, R. M., 2003. Real-time decoding of dopamine concentration changes in the caudate-putamen during tonic and phasic firing. *J Neurochem* 87, 1284–1295.
- Waelti, P., Dickinson, A., Schultz, W., 2001. Dopamine responses comply with basic assumptions of formal learning theory. *Nature* 412, 43–48.
- Wallace, D. G., Hamilton, D. A., Whishaw, I. Q., 2006. Movement characteristics support a role for dead reckoning in organizing exploratory behavior. *Anim Cogn* 9, 219–228.
- Wang, Z., Kai, L., Day, M., Ronesi, J., Yin, H. H., Ding, J., Tkatch, T., Lovinger, D. M., Surmeier, D. J., 2006. Dopaminergic control of corticostriatal long-term synaptic depression in medium spiny neurons is mediated by cholinergic interneurons. *Neuron*, 43–452.
- Whelan, P. J., 1996. Control of locomotion in the decerebrate cat. *Prog Neurobiol* 49, 481–515.
- Whishaw, I. Q., Cassel, J. C., Jarrad, L. E., 1995. Rats with fimbria-fornix lesions display a place response in a swimming pool: a dissociation between getting there and knowing where. *J Neurosci* 15, 5779–5788.
- Whishaw, I. Q., Dunnett, S. B., 1985. Dopamine depletion, stimulation or blockade in the rat disrupts spatial navigation and locomotion dependent upon beacon or distal cues. *Behav Brain Res* 18, 11–29.
- Wickens, J. R., Budd, C. S., Hyland, B. I., Arbutnot, G. W., 2007. Striatal contributions to reward and decision making: making sense of regional variations in a reiterated processing matrix. *Ann N Y Acad Sci* 1104, 192–212.
- Wiener, S. I., 1996. Spatial, behavioral and sensory correlates of hippocampal CA1 complex spike cell activity: implications for information processing functions. *Prog Neurobiol* 49, 335–361.
- Wiener, S. I., Khamassi, M., Peyrache, A., Douchamps, V., Tierney, P., Battaglia, F. P., 2007. Transitions in behaviorally correlated activity in medial prefrontal neurons of rats acquiring and switching strategies in a Y-maze. In: *IBAGS IX. International Basal Ganglia Society, Egmond aan Zee, The Netherlands*, pp. P–114.
- Wilson, C. J., Groves, P. M., 1980. Fine structure and synaptic connections of the common spiny neuron of the rat neostriatum: a study employing intracellular inject of horseradish peroxidase. *J Comp Neurol* 194, 599–615.
- Wilson, D. I. G., MacLaren, D. A. A., Winn, P., 2009. Bar pressing for food: differential consequences of lesions to the anterior versus posterior pedunculo-pontine. *Eur J Neurosci* 30, 504–513.
- Wilson, H. R., Cowan, J. D., 1972. Excitatory and inhibitory interactions in localized populations of model neurons. *Biophys J* 12, 1–24.
- Wilson, M. A., McNaughton, B. L., 1994. Reactivation of hippocampal ensemble memories during sleep. *Science* 265, 676–679.
- Winn, P., 2006. How best to consider the structure and function of the pedunculo-pontine tegmental nucleus: Evidence from animal studies. *J Neurol Sci* 248, 234–250.

- Witter, M. P., Amaral, D. G., 2004. Hippocampal formation. In: Paxinos, G. (Ed.), *The Rat Nervous System*, Third Edition. Elsevier, San Diego, CA, pp. 635–704.
- Wolf, J. A., Finkel, L. H., Contreras, D., 2009. Sublinear summation of afferent inputs to the nucleus accumbens in the awake rat. *J Physiol* 587, 1695–1704.
- Wong, A. C., Shetreat, M. E., Clarke, J. O., Rayport, S., 1999. D1- and D2-like dopamine receptors are co-localized on the presynaptic varicosities of striatal and nucleus accumbens neurons in vitro. *Neuroscience* 89, 221–233.
- Wright, C. I., Beijer, A. V., Groenewegen, H. J., 1996. Basal amygdaloid complex afferents to the rat nucleus accumbens are compartmentally organized. *J Neurosci* 16, 1877–1893.
- Wu, Y., Richard, S., Parent, A., 2000. The organization of the striatal output system: a single cell juxtacellular labeling study in the rat. *Neurosci Res* 38, 49–62.
- Yang, C. R., Mogenson, G. J., 1985. An electrophysiological study of the neural projections from the hippocampus to the ventral pallidum and the subpallidal areas by way of the nucleus accumbens. *Neuroscience* 15, 1015–1024.
- Yang, C. R., Mogenson, G. J., 1987. Hippocampal signal transmission to the pedunculopontine nucleus and its regulation by dopamine D2 receptors in the nucleus accumbens: an electrophysiological and behavioural study. *Neuroscience* 23, 1041–1055.
- Yin, H. H., Knowlton, B. J., 2006. The role of the basal ganglia in habit formation. *Nat Rev Neurosci* 7, 464–476.
- Yun, I. A., Wakabayashi, K. T., Fields, H. L., Nicola, S. M., 2004. The ventral tegmental area is required for the behavioral and nucleus accumbens neuronal firing responses to incentive cues. *J Neurosci* 24, 2923–2933.
- Zaborszky, L., Alheid, G. F., Beinfeld, M. C., Eiden, L. E., Heimer, L., Palkovits, M., 1985. Cholecystokinin innervation of the ventral striatum: a morphological and radioimmunological study. *Neuroscience* 14, 427–453.
- Zahm, D. S., 2006. The evolving theory of basal forebrain functional-anatomical ‘macrosystems’. *Neurosci Biobehav Rev* 30, 148–172.
- Zahm, D. S., Brog, J. S., 1992. On the significance of subterritories in the “accumbens” part of the rat ventral striatum. *Neuroscience* 50, 751–767.
- Zhou, L., Furuta, T., Kaneko, T., 2003. Chemical organization of projection neurons in the rat accumbens nucleus and olfactory tubercle. *Neuroscience* 120, 783–798.
- Zigmond, M. J., Burke, R. E., 2002. Pathophysiology of Parkinson’s Disease. In: Davis, K. L., Charney, D., Coyle, J. T., Nemeroff, C. (Eds.), *Neuropsychopharmacology: The Fifth Generation of Progress*. Lippincott Williams & Wilkins, Philadelphia, pp. 1781–1793.