



UNIVERSITY OF LEEDS

This is a repository copy of *WC2.3 - Probing Ultrafast Switch-on Dynamics of Frequency Tuneable Semiconductor Lasers Using Terahertz Time-domain Spectroscopy (Invited)*.

White Rose Research Online URL for this paper:
<http://eprints.whiterose.ac.uk/150907/>

Version: Accepted Version

Proceedings Paper:

Kundu, I orcid.org/0000-0002-3564-1903, Wang, F, Qi, X et al. (16 more authors) (2019) *WC2.3 - Probing Ultrafast Switch-on Dynamics of Frequency Tuneable Semiconductor Lasers Using Terahertz Time-domain Spectroscopy (Invited)*. In: *Proceedings of the 2019 IEEE Photonics Society Summer Topical Meeting Series (SUM)*. 2019 IEEE Photonics Society Summer Topical Meeting Series (SUM), 08-10 Jul 2019, Ft. Lauderdale, FL, USA. IEEE . ISBN 978-1-7281-0597-0

<https://doi.org/10.1109/PHOSST.2019.8794970>

© 2019 IEEE. This is an author produced version of a paper published in *Proceedings of the 2019 IEEE Photonics Society Summer Topical Meeting Series (SUM)*. Personal use of this material is permitted. Permission from IEEE must be obtained for all other uses, in any current or future media, including reprinting/republishing this material for advertising or promotional purposes, creating new collective works, for resale or redistribution to servers or lists, or reuse of any copyrighted component of this work in other works. Uploaded in accordance with the publisher's self-archiving policy.

Reuse

Items deposited in White Rose Research Online are protected by copyright, with all rights reserved unless indicated otherwise. They may be downloaded and/or printed for private study, or other acts as permitted by national copyright laws. The publisher or other rights holders may allow further reproduction and re-use of the full text version. This is indicated by the licence information on the White Rose Research Online record for the item.

Takedown

If you consider content in White Rose Research Online to be in breach of UK law, please notify us by emailing eprints@whiterose.ac.uk including the URL of the record and the reason for the withdrawal request.



eprints@whiterose.ac.uk
<https://eprints.whiterose.ac.uk/>

Probing ultrafast switch-on dynamics of frequency tuneable semiconductor lasers using terahertz time-domain spectroscopy

Iman Kundu^{1,*}, Feihu Wang², Xiaoqiong Qi³, Hanond Nong², Paul Dean¹, Joshua R. Freeman¹, Alexander Valavanis¹, Gary Agnew³, Andrew T. Grier¹, Thomas Taimre⁴, Lianhe Li¹, Dragan Indjin¹, Juliette Mangeney², Jérôme Tignon², Sukhdeep S. Dhillon², Aleksandar D. Rakić³, John E. Cunningham¹, Edmund H. Linfield¹, A. Giles Davies¹

¹ School of Electronic and Electrical Engineering, University of Leeds, Leeds LS2 9JT, United Kingdom.

² Laboratoire Pierre Aigrain, Département de physique de l'ENS, École normale supérieure, Paris 06, CNRS, 75005 Paris, France.

³ School of Information Technology and Electrical Engineering, The University of Queensland, Brisbane, QLD 4072, Australia

⁴ School of Mathematics and Physics, The University of Queensland, Brisbane, QLD 4072, Australia.

*E-mail: I.Kundu@leeds.ac.uk; ORCID: 0000-0002-3564-1903

Abstract—We report measurements of switch-on dynamics, mode competition and frequency selection in a monolithic frequency-tuneable laser using coherent time-domain sampling of the laser emission. We observe hopping between lasing modes on picosecond-timescales and temporal evolution of transient multi-mode emission into steady-state single mode emission.

Keywords—laser dynamics, semiconductor lasers, terahertz, quantum cascade lasers, ultrafast

I. INTRODUCTION

Frequency tuneable semiconductor lasers form the backbone of modern communication systems. These lasers comprise of multiple cavity sections that are monolithically integrated on a single substrate and exploit the Vernier frequency selection rules for frequency tuning, without the need for external optics. The cavity sections are designed using burst or chirped gratings, or exploiting etalon effects in a Fabry–Pérot resonator to form two combs of longitudinal frequencies. The combs are carefully selected such that they are coincident at a single frequency. In such a laser, emission is selectively favoured at the coincident frequency due to a reduction in the mirror losses and lasing threshold[1]. Additionally, the emission frequency is tuned over a wide

range of frequencies by applying a perturbation to the refractive index in one or more cavities.

Although single-mode emission and frequency tuning characteristics of diode lasers in the steady-state are well established, a study of the ultrafast switch-on, mode competition and frequency selection dynamics are technologically challenging due to the lack of ultrafast coherent detection techniques. Here we have exploited phase-resolved sampling of electric field emitted using terahertz frequency time domain spectroscopy[2] to study ultrafast switch-on dynamics in a frequency tuneable quantum cascade laser (QCL)[3] [Fig. 1]. We have measured temporal evolution of transient multi-mode emission into a single-mode emission over picosecond and nanosecond timescales[4]. We also observe a systematic variation of the laser switch-on time as a function of Vernier alignment. The device operation was simulated using transfer matrices, reduced rate equations and a full Schrödinger–Poisson energy balance rate equation model[5]. The changes in laser stabilisation time, calculated from the model, are in agreement with the variations in the switch-on delay observed experimentally.

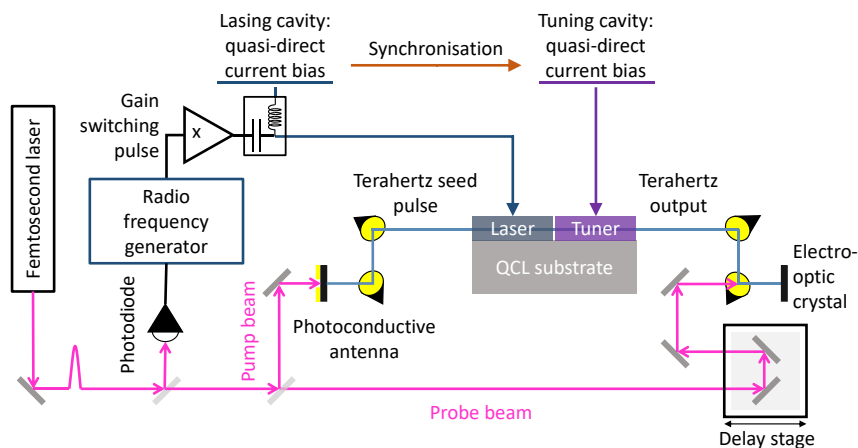

Fig. 1 Schematic diagram of the experimental setup. A coupled-cavity terahertz QCL with an active laser section and a passive tuner section was used in the experiments. The active laser section was driven above threshold, whereas the tuner section was driven at sub-threshold currents and was used to tune the emission frequency of the coupled-cavity QCL. Femtosecond laser pulses were generated using a Ti:Sapphire laser that was split to form a pump and a probe beam. A fraction of this ultrashort pulse power was also used to trigger a radio frequency source to generate a train of gain switching pulses that were mixed with a quasi-dc source using a diplexer. The dc amplitude was maintained at just below the lasing threshold such that the QCL was driven above threshold by the radio frequency controlled gain-switching pulses. This arrangement allowed a synchronisation of the QCL switching-on with the femtosecond laser pulses. Another quasi-dc pulse generator was synchronised with the first dc source and was used to drive the tuning cavity. The pump beam was focused onto a photoconductive antenna to generate broadband terahertz pulses, which were injected into the QCL cavity to seed the emission. The terahertz field emitted from the facet of the tuning section was measured using an electro-optic crystal with the time-delayed probe beam.

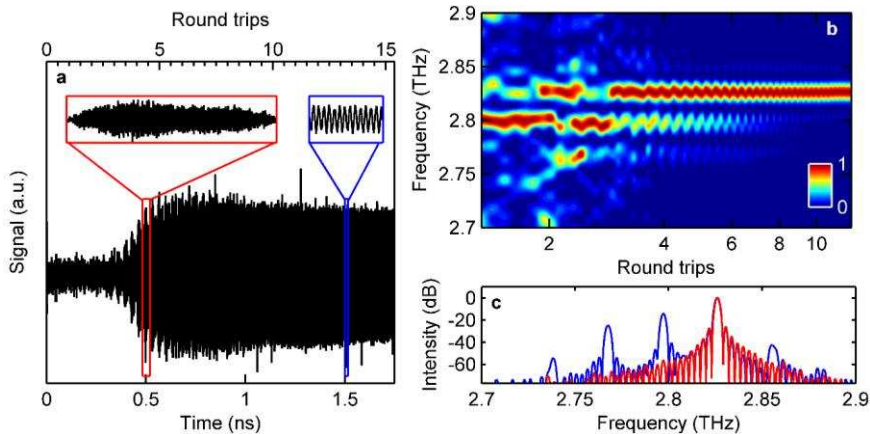

Fig. 2 (a) The electric field measured from the output facet of the tuning cavity, when the lasing cavity is driven using quasi-dc pulses of amplitude 0.65 A and the tuning cavity is switched off. Inset: Electric field at ~ 500 ps and 1500 ns. (b) Spectrogram showing dynamic variation of the emission frequencies obtained from fast Fourier transforms of the time-domain electric field using a moving time window of width 150 ps. (c) Emission spectra calculated from fast Fourier transform of the time-domain electric field using a 460-ps-wide time window beginning at 400 ps (blue) and 1700 ps (red).

II. RESULTS

A 4.81-mm-long terahertz QCL with a bound-to-continuum active region[6] was used in the experiments. Focussed ion beam milling was used to form a 3.43-mm-long tuning cavity and a 1.38-mm-long lasing cavity, which were separated by a 13- μm -wide air gap. Initially, the steady-state frequency tuning characteristics were measured using a Fourier transform infrared spectrometer as the current supplied to the tuning cavity was increased in the range 0–2 A and the laser cavity was driven at peak output power with quasi-dc amplitude 0.75 A. A mode-hop from 2.825 to 2.765 THz was observed at a tuning cavity current of ~ 1.65 A (not shown).

The temporal dynamics of the QCL emission were characterised using the injection seeding technique, initially with the tuning cavity switched off. A periodic modulation of the electric field amplitude, typical of multi-mode emission, was measured before a stable single-mode emission was established [Fig. 2(a)]. The measured electric field was analysed using fast Fourier transforms on a moving window to form a spectrogram [Fig. 2(b) and (c)]. Transient mode hops was observed within the first ~ 500 ps before a steady-state single mode was established after ~ 1 ns.

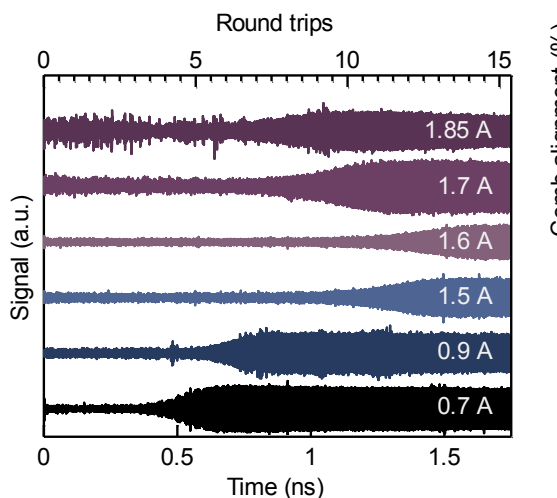

Fig. 3 The electric field from the QCL measured at different current amplitudes in the tuning cavity. The lasing cavity is driven using quasi-dc pulses of amplitude 0.65 A.

The QCL emission was also recorded while the current amplitude of the tuning cavity was increased from 0–2 A [Fig. 3]. The switch-on delay was observed to increase as the tuning current was increased in the range 0–1.6 A, corresponding to a progressive misalignment of the frequency combs and an increase in the effective mirror losses at 2.825 THz. However, the switch-on delay decreased after the mode-hop from 2.825 THz to 2.765 THz at tuning currents > 1.6 A.

III. CONCLUSIONS

In this presentation, we will present this experimental data together with a mathematical model of the Vernier devices. We will also report the effect frequency tuning on stabilisation time in a QCL with finite defect sites.

ACKNOWLEDGMENT

This work has been supported by the Engineering and Physical Sciences Research Council, UK (‘COTS’ and ‘HyperTerahertz’ programmes, EP/J017671/1 and EP/P021859/1); European Union FET-Open grant ULTRAQCL 665158; the European Cooperation in Science and Technology Action BM1205; Centre National de la Recherche Scientifique, France; Australian Research Council’s Discovery Projects Funding Scheme (Grant DP 160 103910) and a Royal Society International Exchange grant (IE120898). E.H.L. and A.G.D. are grateful for support from the Royal Society and Wolfson Foundation.

REFERENCES

- [1] L. A. Coldren, S. W. Corzine, and M. L. Masanovic, *Diode Lasers and Photonic Integrated Circuits*, Second. John Wiley & Sons, 2012.
- [2] D. Oustinov *et al.*, “Phase seeding of a terahertz quantum cascade laser,” *Nat. Commun.*, vol. 1, p. 69, Sep. 2010.
- [3] I. Kundu *et al.*, “Discrete Vernier tuning in terahertz quantum cascade lasers using coupled cavities,” *Opt. Express*, vol. 22, no. 13, pp. 16595–16605, 2014.
- [4] I. Kundu *et al.*, “Ultrafast switch-on dynamics of frequency tuneable semiconductor lasers,” *Nat. Commun.*, vol. 9, no. 1, p. 3076, Aug. 2018.
- [5] X. Qi *et al.*, “Mode selection and tuning mechanisms in coupled-cavity terahertz quantum cascade lasers,” *IEEE J. Sel. Top. Quantum Electron.*, vol. 23, no. 4, pp. 1–12, 2017.
- [6] S. Barbieri, J. Alton, H. E. Beere, J. Fowler, E. H. Linfield, and D. A. Ritchie, “2.9 THz quantum cascade lasers operating up to 70 K in continuous wave,” *Appl. Phys. Lett.*, vol. 85, no. 10, pp. 1674–1676, 2004.