

This is a repository copy of *Refuting the nature of the sixth 0+ Hoyle-analogue state candidate in 16O*.

White Rose Research Online URL for this paper:

<https://eprints.whiterose.ac.uk/142775/>

Version: Published Version

Article:

Li, K. C.W., Adsley, P., Neveling, R. et al. (14 more authors) (2017) Refuting the nature of the sixth 0+ Hoyle-analogue state candidate in 16O. *Proceedings of Science*. 040. ISSN 1824-8039

<https://doi.org/10.22323/1.281.0040>

Reuse

This article is distributed under the terms of the Creative Commons Attribution-NonCommercial-NoDerivs (CC BY-NC-ND) licence. This licence only allows you to download this work and share it with others as long as you credit the authors, but you can't change the article in any way or use it commercially. More information and the full terms of the licence here: <https://creativecommons.org/licenses/>

Takedown

If you consider content in White Rose Research Online to be in breach of UK law, please notify us by emailing eprints@whiterose.ac.uk including the URL of the record and the reason for the withdrawal request.

Refuting the nature of the sixth 0^+ Hoyle-analogue state candidate in ^{16}O

K. C. W. Li*,^{a,b} P. Adsley,^{a,b} R. Neveling,^b P. Papka,^{a,b} F. D. Smit,^b J. W. Brümmer,^{a,b} C. Aa. Diget,^c M. Freer,^d M. N. Harakeh,^e Tz. Kokalova,^d F. Nemulodi,^b L. Pellegri,^{b,f} B. Rebeiro,^g J. A. Swartz,^h S. Triambak,^g J. J. van Zyl,^a and C. Wheldon^d

^aDepartment of Physics, University of Stellenbosch, Private Bag XI, 7602 Matieland, South Africa

^biThemba LABS, National Research Foundation, PO Box 722, Somerset West 7129, South Africa

^cDepartment of Physics, University of York, Heslington, York YO10 5DD, United Kingdom

^dSchool of Physics and Astronomy, University of Birmingham, Birmingham, B15 2TT, United Kingdom

^eUniversity of Groningen, KVI Center for Advanced Radiation Technology, 9700 AB Groningen, The Netherlands

^fSchool of Physics, University of the Witwatersrand, Johannesburg 2050, South Africa

^gDepartment of Physics, University of the Western Cape, Bellville ZA-7535, South Africa

^hKU Leuven, Instituut voor Kern- en Stralingsfysica, Celestijnenlaan 200D, B-3001 Leuven, Belgium

ⁱiThemba LABS, National Research Foundation, PO Box 722, Somerset West 7129, South Africa

E-mail: kcwli@sun.ac.za, padsley@gmail.com, neveling@tlabs.ac.za, papka@sun.ac.za, smit@tlabs.ac.za, jbrummer@sun.ac.za, christian.diget@york.ac.uk, m.freer@bham.ac.uk, m.n.harakeh@kvi.nl, t.kokalova@bham.ac.uk, fnemulodi@yahoo.com, luna.pellegrini@gmail.com, b.rebeiro@gmail.com, jacobus.swartz@phys.au.dk, smarajit@gmail.com, jjvz@sun.ac.za, c.wheldon@bham.ac.uk.

A prominent candidate for a Hoyle-analogue state in ^{16}O is the 0_6^+ state, previously observed at $E_x = 15.097(5)$ MeV. This state is identified by several theoretical cluster calculations to be a good candidate for the $4\text{-}\alpha$ cluster state, analogous to the Hoyle state in ^{12}C . Whilst much theoretical work has been performed to reconcile a calculated α -cluster state with this resonance, the experimental information on this state remained very scarce. To investigate this state, the $^{16}\text{O}(\alpha, \alpha')$ reaction was studied at $\theta_{lab} = 0^\circ$ at an incident energy of $E_{lab} = 200$ MeV using the K600 magnetic spectrometer at iThemba LABS. For the first time, the decay channels of the $E_x = 15.097(5)$ MeV state were isolated using a large acceptance silicon-strip detector array at backward angles. The lineshapes of the states were analysed within a phenomenological R-matrix framework. Results indicate the presence of a resonance at $E_x \approx 15$ MeV which does not exhibit a $J^\pi = 0^+$ nature.

*The 26th International Nuclear Physics Conference
11-16 September, 2016
Adelaide, Australia*

*Speaker.

1. Introduction

The search for Hoyle-like states in nuclei has recently garnered much interest in both experimental and theoretical realms. A prominent candidate for a Hoyle-analogue state in ^{16}O is the 0_6^+ state, previously observed at $E_x = 15.097(5)$ MeV with a width of $\Gamma = 166(30)$ keV [1]. This state is identified by several theoretical cluster calculations to be a good candidate for the $4\text{-}\alpha$ cluster state [2, 3, 4], analogous to the Hoyle state in ^{12}C . This candidate, theoretically calculated to be 2 MeV above the four α -particle breakup threshold of $S_{4\alpha} = 14.437$ MeV, satisfies the Ikeda prescription for cluster formation [5]. The relatively narrow width of this resonance, with respect to its high excitation energy above the four α -particle breakup threshold, is indicative of a relatively long lifetime: a presumed characteristic of Hoyle-like states [4]. Whilst much theoretical work has been performed to reconcile a calculated α -cluster state with this resonance, the experimental information on this state remained very scarce. The primary goal of this work was therefore to provide a more definitive characterisation of the nature of this state and extract the branching ratios of decay channels. Recent attempts to thoroughly investigate this resonance have been unsuccessful [6, 7], necessitating further investigation.

2. Experimental Method

To study the branching ratios of the 0_6^+ state in ^{16}O , the low spin natural parity states of ^{16}O were populated with a very selective nuclear reaction. The chosen $^{16}\text{O}(\alpha, \alpha')$ reaction, with an incident beam energy of $E_{lab} = 200$ MeV, was measured at $\theta = 0^\circ$ (defined by a circular collimator with an opening angle of $\Delta\theta_{lab} = \pm 2^\circ$). An advantage of this particular measurement is the dom-

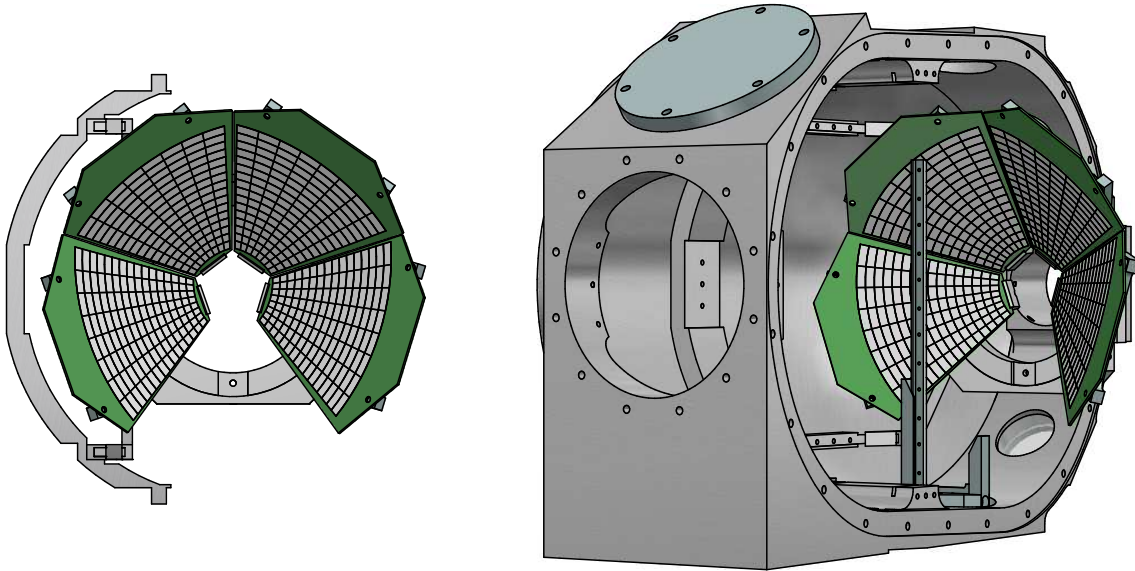

Figure 1: The CAKE silicon detector array, comprised of 4 (out of a possible 5) MMM-type detectors. The array was mounted at backward angles, spanning a polar-angle range of: $117^\circ < \theta_{lab} < 166^\circ$. The minimum distance between the target and the active area of the CAKE was approximately 100(2) mm and the total solid angle subtended by the array in this configuration was approximately 20.4(5)% of 4π .

inance of a single-step direct reaction mechanism which suppresses the population of unnatural parity states. The excited states in ^{16}O were identified using the focal plane detector system of the K600 magnetic spectrometer [8] and the coincident charged-particle decay was detected using a double-sided silicon strip detector (DSSSD) array known as the Coincidence Array for K600 Experiments (CAKE) [9] (see Figure 1). A $510\text{-}\mu\text{g}/\text{cm}^2$ -thick $^{\text{nat}}\text{Li}_2\text{CO}_3$ target was used [10]. The target was prepared on a $50\text{-}\mu\text{g}/\text{cm}^2$ -thick ^{12}C backing and the total Li content was approximately $50\text{-}\mu\text{g}/\text{cm}^2$. To gauge the contamination from the carbon backing, an additional ^{12}C target was also studied. The focal plane energy resolution was $85(1)$ keV FWHM, as determined from the $12.049(9)$ MeV $J^\pi = 0^+$ resonance in ^{16}O . The error on the calculated excitation energy was $\delta E_x < 9$ keV. A comprehensive description of the experimental and analysis techniques is reported elsewhere [11].

3. Results

The detection of coincident charged-particle decay enabled the discrimination of decay modes through the coincident matrix of silicon energy versus excitation energy of the recoil nucleus, as displayed in Figure 2 (a). The α_0 , α_1 and p_{0-3} decay lines from ^{16}O are clearly observed. By projecting the α_0 , p_0 and α_1 decay loci onto excitation energy, the lineshapes of each decay mode can be analysed separately, as displayed on spectra (b), (c) and (d) respectively. The α -particle and proton decay at $E_x \approx 15$ MeV are focused upon in Figures 3 and 4 respectively. The lithium breakup is kinematically well-separated from the decays of interest from ^{16}O . The ^6Li and ^7Li contributions to the observed excitation energy range form a continuum due to their relatively low α -separation energies of $E_{sep} = 1.47$ and 2.47 MeV respectively. These focal plane spectra were analysed within a phenomenological single-channel R-matrix framework which prescribes a resonance with an intrinsic Lorentzian lineshape with an energy-dependant width $\Gamma(E)$:

$$N(E) \propto \frac{\Gamma(E)}{[E - E_R]^2 + [\Gamma(E)/2]^2}, \quad (3.1)$$

where E_R and E represent the resonance energy and the excitation energy of the nucleus respectively. The partial width for the i^{th} decay channel, $\Gamma_i(E)$, is given by

$$\Gamma_i(E) = 2\gamma_i^2 P_i(E), \quad (3.2)$$

where the γ_i and $P_i(E)$ represent the reduced width and penetrability of the decay channel. To account for the inherent energy resolution of the focal plane spectra, the observed lineshape of a resonance takes the form of a Voigt lineshape [12]: a convolution of the Gaussian lineshape with the aforementioned R-matrix Lorentzian lineshape.

The electronic segmentation of the CAKE array enables the gating of events detected at particular rings. The corresponding ring-gated focal plane spectra are also fitted with the same R-matrix formalism to extract the angular correlations of decay in the laboratory reference frame, as shown in Figure 5. To ensure that the extracted resonance parameters are consistent within each decay mode, the full data set for each decay mode is initially fitted. The extracted parameters are then

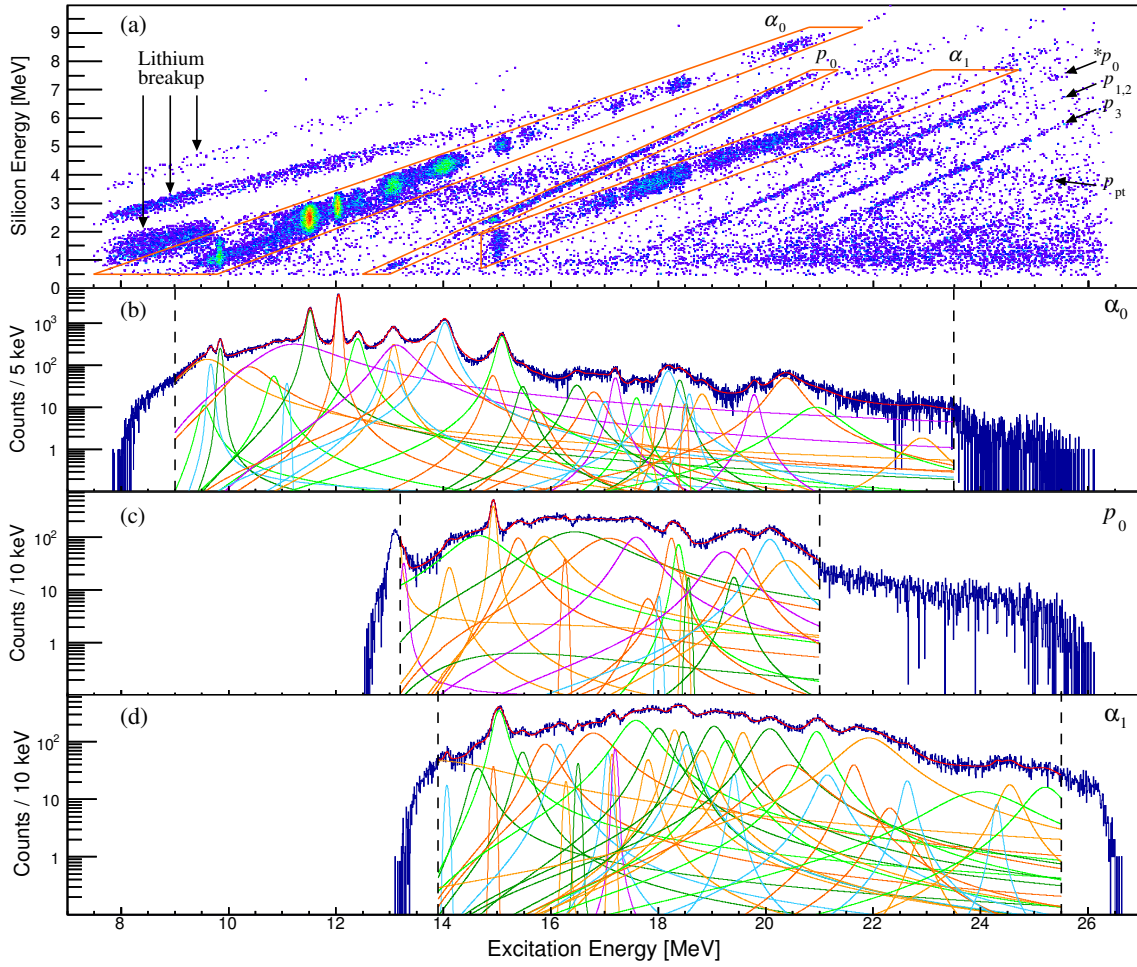

Figure 2: (a): The coincident matrix of silicon energy versus the excitation energy of the recoil nucleus for decay particles detected within the angular range: $156^\circ < \theta_{lab} < 163^\circ$ (two strips within the array). The α_0 , α_1 and p_{0-3} decay lines from ^{16}O are indicated. The proton punchthrough structure from the p_0 decay is labelled $p_{p.t.}$. The lithium breakup and the $*p_0$ decay line from ^{12}C are indicated. A display color threshold of >1 is imposed. The projections of the α_0 , p_0 and α_1 decay loci onto excitation energy are displayed in spectra (b), (c) and (d) respectively. The ranges of each single-channel R-matrix fit are indicated with dashed lines.

fixed for the fitting of the ring-gated data: only the amplitudes of the resonances are free parameters. This not only enforces self-consistency of the results, but also suppresses the volatile nature of yield extraction from unresolved resonances which are intrinsically broad and overlapping.

To calculate the theoretical angular correlations of decay a distorted-wave Born approximation was used to describe the $^{16}\text{O}(\alpha, \alpha')$ reaction, using the CHUCK3 code [13]. ANGCOR [14] was then employed to calculate the m -state population ratios which are used to determine the angular correlations of decay [15].

4. Discussion

4.1 The 0_6^+ state in ^{16}O

In the inclusive focal plane spectrum, a prominent resonance at $E_x = 15.076(7)$ MeV is observed with a width of $\Gamma = 162(4)$ keV, displayed on Figure 3 (a). This is in relatively good agreement with the corresponding literature values of $E_x = 15.097(5)$ MeV and $\Gamma = 166(30)$ keV. Whilst the widths extracted from the inclusive and α_0 -gated spectra are in good agreement ($\Gamma = 162(4)$ and $164(1)$ keV respectively), the corresponding $\Gamma = 216(10)$ keV width extracted from the α_1 -decay spectrum on Figure 3 (c) is inconsistent.

The 0_6^+ resonance was not fully resolved from the neighbouring $14.930(8)$ MeV $J^\pi = 2^+$ resonance in ^{16}O , shown on Figure 4 (a). There is a similar inconsistency between the widths extracted from the inclusive and p_0 -gated spectra of $101(3)$ and $40(1)$ keV respectively: the p_0 -extracted width agrees better with the literature value of $54(5)$ keV. These two inconsistencies regarding inclusive and particle-gated widths are indicative of a previously unidentified resonance at $E_x \approx 15$ MeV.

All decay channels from a $J^\pi = 0^+$ resonance are isotropic in the reference frame of the parent nucleus. On Figure 5 (e), one observes that the α_1 decay agrees well to the calculated angular cor-

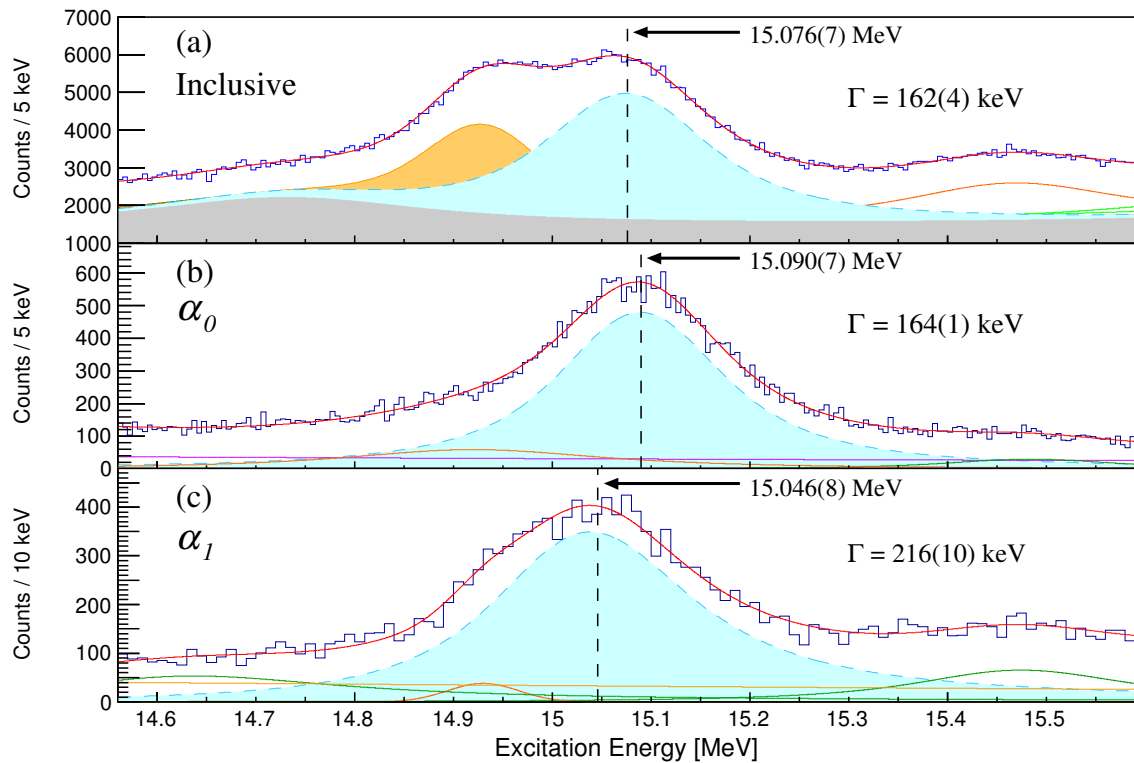

Figure 3: (a) The inclusive focal plane spectrum at $E_x \approx 15$ MeV, highlighting the $15.076(7)$ MeV 0_6^+ resonance in ^{16}O (displayed with a dashed blue line and blue shading). The neighbouring $14.930(8)$ MeV $J^\pi = 2^+$ resonance in ^{16}O is displayed with a solid orange line and orange shading. The total lithium background is shaded in grey. The projections of the α_0 and α_1 decay loci onto excitation energy are displayed in spectra (b) and (c) respectively. The resonance energy and width of each resonance of interest is indicated.

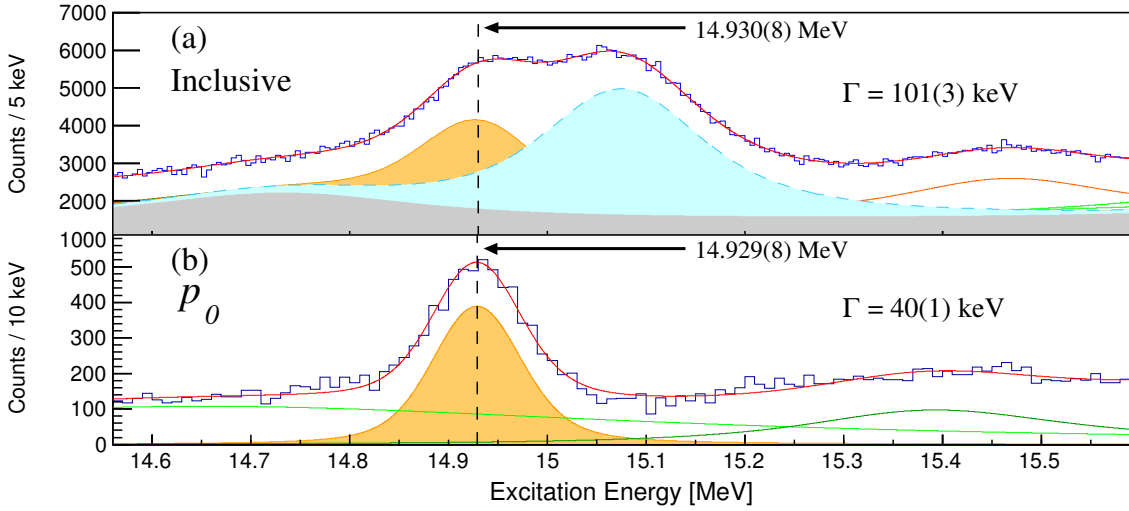

Figure 4: (a) The inclusive focal plane spectrum at $E_x \approx 15$ MeV, highlighting the 14.930(8) MeV $J^\pi = 2^+$ resonance in ^{16}O (displayed with a solid orange line and orange shading). The neighbouring 15.076(7) MeV 0_6^+ resonance in ^{16}O is displayed with a dashed blue line and blue shading. The total lithium background is shaded in grey. The projection of the p_0 decay locus onto excitation energy is displayed in spectrum (b). The resonance energy and width of each resonance of interest is indicated.

relation from a $J^\pi = 0^+$ resonance, however the α_0 decay on Figure 5 (f) exhibits clear anisotropy. This can only occur from a resonance with non-zero spin. The angular correlation of the p_0 decay from the neighbouring 14.929(8) MeV $J^\pi = 2^+$ state is well understood and fits well to the calculation on Figure 5 (c). To check that the α_0 decay of the 0_6^+ state is not contaminated by the neighbouring $J^\pi = 2^+$ state, the α_0 decay from the well-resolved and strongly populated 11.521(9) MeV $J^\pi = 2^+$ state was also analyzed, as shown in Figure 5 (a). This $J^\pi = 2^+$ α_0 angular correlation agrees relatively well to the associated calculation ($\chi_{\text{red}}^2 = 1.42$) and is qualitatively different to the correlation in Figure 5 (f). Moreover, none of the calculated α_0 angular correlations from $J^\pi = 0^+, 1^-, 2^+, 3^-, 4^+, 5^-$ resonances fit the data well. Assuming that the α_0 decay from an unidentified resonance of non-zero spin is contaminating the angular correlation, all possible pairs of the calculated correlations were incoherently summed and fitted to the data (with the relative contributions being free parameters). The best fitting combination is poor with $\chi_{\text{red}}^2 = 7.67$, corresponding to a combination of $J^\pi = 0^+$ and 1^- resonances. This may result from the coherent interference of particle decay from two distinct and intrinsically overlapping resonances.

4.2 Known 0^+ states observed in ^{16}O below the four α -particle breakup threshold

The strongly populated 12.049(8) MeV $J^\pi = 0^+$ resonance is the most highly resolved on the focal plane spectra and is consequently an appropriate example for comparison to the 0_6^+ state. The angular correlation of α_0 decay from this resonance agrees well with calculation with $\chi_{\text{red}}^2 = 1.01$, as displayed on Figure 5 (d).

The angular correlation of the 14.029(8) MeV $J^\pi = 0^+$ yields a poorer fit to calculation with $\chi_{\text{red}}^2 = 2.90$, however it is still qualitatively isotropic. This disagreement is probably due to the fact that this resonance is not well resolved from the surrounding excitation energy region (13 MeV

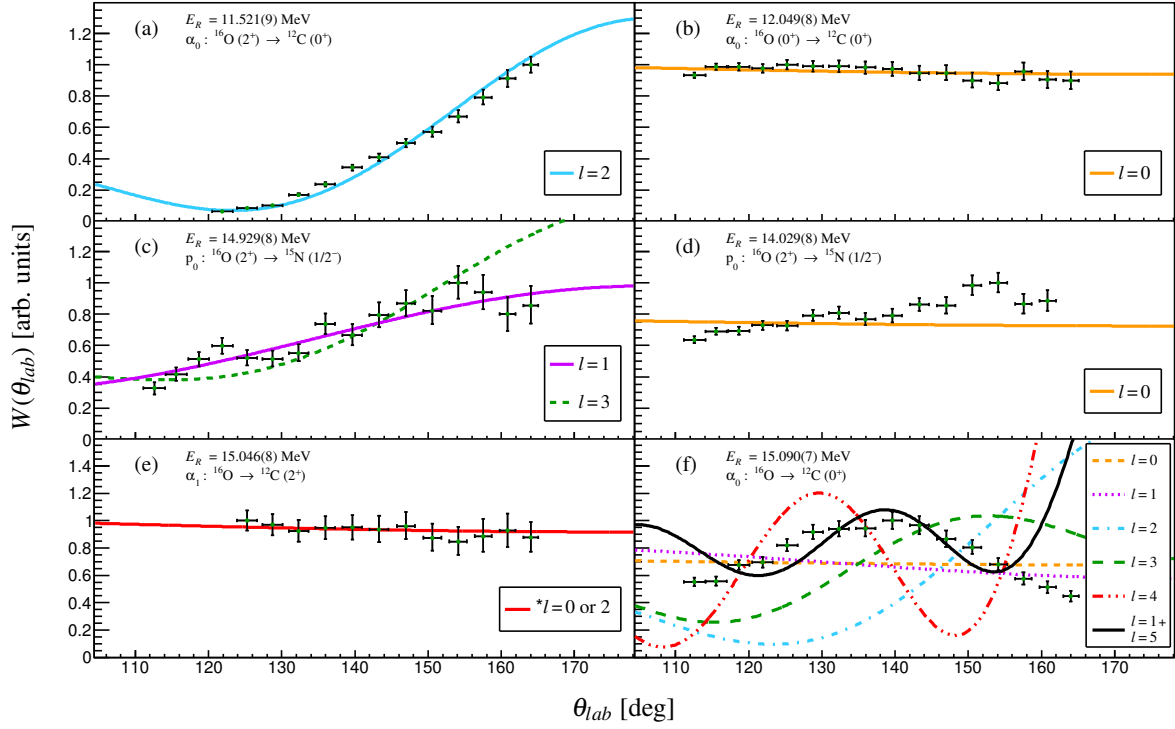

Figure 5: Angular correlations of charged particle decays from the resonances of interest in ^{16}O , displayed in the laboratory frame relative to the beam axis: (a) α_0 decay from the 11.521(9) MeV $J^\pi = 2^+$ resonance, (b) α_0 decay from the 12.049(8) MeV $J^\pi = 0^+$ resonance, (c) p_0 decay from the 14.929(8) MeV $J^\pi = 2^+$ resonance, (d) α_0 decay observed at 14.029(8) MeV, (e) α_1 decay observed at 15.046(8) MeV, (f) α_0 decay observed at 15.090(7) MeV. *The α_0 decays from $J^\pi = 0^+$ and 2^+ resonances, corresponding to $l = 0\hbar$ and $2\hbar$ respectively, exhibit the same angular correlations. Data points affected by the electronic thresholds of the CAKE array are omitted.

$< E_x < 14$ MeV) which is dense with wide and overlapping resonances.

5. Conclusion

The measurement of the $^{16}\text{O}(\alpha, \alpha')$ reaction at $\theta_{lab} = 0^\circ$ was successful in populating the 0_6^+ state in ^{16}O , observed at $E_x = 15.076(7)$ MeV with a width of $\Gamma = 162(4)$ keV from the inclusive focal plane data. This is in good agreement with the literature values of $E_x = 15.097(5)$ MeV and $\Gamma = 166(30)$ keV, however upon further inspection, some of the parameters extracted from the inclusive and particle-gated spectra at $E_x \approx 15$ MeV are inconsistent. Together with the clear anisotropy of the α_0 decay observed at $E_x = 15.090(7)$ MeV, this data suggests the existence of a previously unidentified resonance of non-zero spin at $E_x \approx 15$ MeV. The analysis of the other observed resonances confirm that this anisotropy is not a consequence of the analysis method. Such a resonance is likely to have contaminated previous measurements of this Hoyle-analogue state candidate by augmenting the measurement of the resonance width. This is significant as a narrow width, with respect to a high excitation energy above the α -disintegration threshold ($S_{4\alpha} =$

14.437 MeV for ^{16}O), is a presumed characteristic of Hoyle-like states. This data may explain the disparity between the theoretical and experimentally observed widths of 34 keV and 166(30) keV respectively. Investigation into the 0_6^+ Hoyle-analogue state candidate in ^{16}O is ongoing.

References

- [1] N. N. D. Center, *Nuclear Science References*, version of (2016).
- [2] P. Schuck, Y. Funaki, H. Horiuchi, G. Röpke, A. Tohsaki and T. Yamada, *Alpha-particle condensation in nuclear systems*, *J. Phys.: Conf. Ser.* **413** (2013) .
- [3] Y. Funaki, T. Yamada, A. Tohsaki, H. Horiuchi, G. Röpke and P. Schuck, *Microscopic study of 4α -particle condensation with inclusion of resonances*, *Phys. Rev. C* **82** (Aug, 2010) 024312.
- [4] Y. Funaki, H. Horiuchi, W. von Oertzen, G. Röpke, P. Schuck, A. Tohsaki et al., *Concepts of nuclear α -particle condensation*, *Phys. Rev. C* **80** (Dec, 2009) 064326.
- [5] Y. Funaki, T. Yamada, H. Horiuchi, G. Röpke, P. Schuck and A. Tohsaki, *α -particle condensation in ^{16}O studied with a full four-body orthogonality condition model calculation*, *Phys. Rev. Lett.* **101** (Aug, 2008) 082502.
- [6] P. J. Haigh, M. Freer, N. I. Ashwood, T. Bloxham, N. Curtis, H. G. Bohlen et al., *Alpha decay widths of excited states of ^{16}O* , *J. Phys. G: Nucl. Part. Phys.* **37** (2010) 035103.
- [7] C. Wheldon, N. I. Ashwood, M. Barr, N. Curtis, M. Freer, T. Kokalova et al., *High-resolution measurement of absolute α -decay widths in ^{16}O* , *Phys. Rev. C* **83** (Jun, 2011) 064324.
- [8] R. Neveling, H. Fujita, F. D. Smit, T. Adachi, G. P. A. Berg, E. Z. Buthelezi et al., *High energy-resolution zero-degree facility for light-ion scattering and reactions at iThemba LABS*, *Nucl. Instrum. Methods Phys. Res. A* **654** (oct, 2011) 29–39.
- [9] P. Adsley et al., *CAKE: The Coincidence Array for K600 Experiments*, 1610.08053.
- [10] P. Papka, N. Y. Kheswa, M. Msimanga, C. Pineda-Vargas and N. S. Soić, *Characterisation of natural and enriched oxygen targets in lithium carbonate foils*, *J. Radioanal. Nucl. Chem.* **305** (2015) 713–716.
- [11] K. C. W. Li, *Masters Thesis, Stellenbosch University and iThemba LABS*, <http://hdl.handle.net/10019.1/97982> (2015) .
- [12] R. Wells, *Rapid approximation to the voigt/faddeeva function and its derivatives*, *J. Quant. Spec. Rad. Trans.* **62** (1999) 29 – 48.
- [13] J.R. Comfort and M.N. Harakeh, *Program CHUCK3, (1979). Modified version of CHUCK by P.D. Kunz, University of Colorado, unpublished* .
- [14] M. N. Harakeh and L. W. Put, *ANGCOR - An angular correlation program, Internal Report KVI-76 (1979)* .
- [15] K. C. W. Li, R. Neveling, P. Adsley, P. Papka, F. D. Smit et al., *Characterization of the proposed $4\text{-}\alpha$ cluster state candidate in ^{16}O* , 1610.07437v2.