



This is a repository copy of *A Hybrid Wireless PLL for Phase Shift Control Based Maximum Efficiency Point Tracking in Resonant Wireless Power Transmission Systems*.

White Rose Research Online URL for this paper:

<https://eprints.whiterose.ac.uk/135061/>

Version: Accepted Version

Proceedings Paper:

Zhao, R., Gladwin, D.T. orcid.org/0000-0001-7195-5435 and Stone, D.A. orcid.org/0000-0002-5770-3917 (2017) A Hybrid Wireless PLL for Phase Shift Control Based Maximum Efficiency Point Tracking in Resonant Wireless Power Transmission Systems. In: IECON 2017 - 43rd Annual Conference of the IEEE Industrial Electronics Society. 43rd Annual Conference of the IEEE Industrial Electronics Society, 29 Oct - 01 Nov 2017, Beijing, China. IEEE , pp. 5301-5306.

<https://doi.org/10.1109/IECON.2017.8216918>

Reuse

Items deposited in White Rose Research Online are protected by copyright, with all rights reserved unless indicated otherwise. They may be downloaded and/or printed for private study, or other acts as permitted by national copyright laws. The publisher or other rights holders may allow further reproduction and re-use of the full text version. This is indicated by the licence information on the White Rose Research Online record for the item.

Takedown

If you consider content in White Rose Research Online to be in breach of UK law, please notify us by emailing eprints@whiterose.ac.uk including the URL of the record and the reason for the withdrawal request.



eprints@whiterose.ac.uk
<https://eprints.whiterose.ac.uk/>

A Hybrid Wireless PLL for Phase Shift Control Based Maximum Efficiency Point Tracking in Resonant Wireless Power Transmission Systems

Rui. Zhao, Daniel. T. Gladwin and David. A. Stone
Department of Electronic and Electrical Engineering
University of Sheffield
Sheffield, United Kingdom
r.zhao@sheffield.ac.uk

Abstract— The application of Wireless Power Transfer (WPT) systems is primarily limited by its energy transfer efficiency. For modern WPT that utilises Strongly Coupled Magnetic Resonances (SCMR), which transfers energy by using the mutual inductance between coils, a higher efficiency can be achieved compared with a conventional air-core transformer module. An SCMR normally works at a desired frequency which is typically the self-resonant frequency of the receiver. However, this frequency varies during system operation where a changing environment, moving coil positions and variable loads may occur. In this paper, a hybrid wireless Phase Lock Loop (PLL) is proposed to lock the phase difference between the WPT's transmitting current and receiving voltage, at which point the system achieves maximum efficiency. A prototype WPT system is built verifying that the proposed wireless PLL effectively controls the wireless power system and operates at optimal frequencies under varying conditions.

Keywords: *Wireless power, Hybrid Wireless Fast Fourier Transform Phase-Locked Loop (HyWi-FFTPLL), measurements in hazards environment*

I. INTRODUCTION

During recent decades, distributed power generation and storage technologies have been increasingly considered, such as distributed solar farms and large-scale battery energy storage [1-3]. In order to interface generated power to the national grid, high voltage grid-connected inverters have been widely used in those distributed generation systems. To protect both the national grid and the end user, the thermal performance and electrical characteristics of the HV side need to be measured and analysed. However, a series of technical problems need to be solved when applying those monitoring methods into a distributed generation system. In a commonly-used system, the bus bar temperature and HV phase angle are normally considered as the critical parameters. For a high-end industrial application, the bus-bar temperature can be measured by infrared temperature sensor and thermometer [4]. However, the poor accuracy, cost and isolation requirement makes this less desirable for distributed generation systems.

In order to resolve those issues, wireless communications can be utilised. For the bus-bar temperature sensing, Industrial Supervision and Monitoring (ISM) systems have been widely

deployed where the temperature sensor can be mounted onto the bus bar which then transfers the measured data wirelessly [5]. Limited by the isolation regulation and wiring practicability, a large amount of ISMs are battery powered. Replacing its battery periodically will not only interrupt data collection but also is costly with significant health and safety considerations [4]. The current rapid development of wireless power technology provides an optimised solution to deliver uninterrupted power and wireless communication to those distributed sensor networks.

To achieve high-efficiency, a WPT system must operate at an optimised frequency equal to the self-resonant frequency of the power receiver [6]. However, the self-resonant frequency of the power receiver is calculated by its capacitance and inductance (LC resonator as an example), which can vary with changes in temperature, load impedance, and physical fluctuations [7, 8]. Since controlling the temperature of the receiving coil is relatively difficult for an ISM system, continuous measurement of the self-resonant frequency of the working receiver is desired, however this is a challenge.

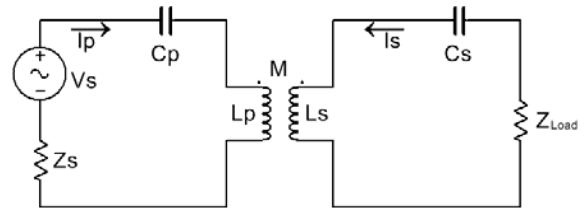

Fig. 1: SCMR under analyses with double series capacitor connection

Zhao et al., have previously presented a phase shift control based Maximum Efficiency Point Tracking (MEPT) [9]. As shown in Fig. 1, without calculating the real-time resonant frequency, the relationship between the output frequency of V_s and the real time self-resonant frequency of $L_s C_s$ can be observed by comparing the phase difference between the current of the first resonator and the output voltage of the second resonator.

In conventional resonant power converters, a Phase Lock Loop (PLL) is widely used to ensure the converter operates in its resonant region and maintains a constant, regulated output. A PLL is a closed loop system that locks its output phase to the input signal with a constant phase difference [10]. However, there are problems utilising a conventional PLL for a wireless power system due to the large bandwidth requirements required to compare the phase difference wirelessly. In this paper, a

novel Hybrid Wireless Fast Fourier Transform Phase-Locked Loop (HyWi-FFTPLL) methodology is proposed. The HyWi-FFTPLL provides a practical approach to utilising PLL in wireless power systems, and provides the functionality to track the wireless receiver's optimised operating point 'on the fly'. This ensures the wireless power system is operating at a high-efficiency point, and is robust to load and operating environment changes. In the following sections, the operational theory for HyWi-FFTPLL is described and a novel frequency domain feedback method is proposed to reduce the communication bandwidth requirement. Simulink simulation of the proposed methods is first provided, followed by results from a hardware prototype built for model validation.

II. CONVENTIONAL PLL

The typical structure of a basic PLL includes a phase detector, loop filter and Voltage Controlled Oscillator (VCO). The phase detector provides a signal which describes the phase difference between its two inputs. The output of the phase detector is then fed into a loop filter to provide DC levels indicating the phase difference, where the DC level will be used to control a VCO to provide the output [10, 11-12]. For most widely used PLLs, the performance can be characterised by the loop filter [13]. Fig. 2 shows a typical PLL dominated induction heating system. As can be seen from the figure, the phase difference between the output voltage of the half bridge and the resonant current is calculated. The phase difference is then used to control the VOC so that when the load condition is changed (i.e. the distances between the work head and the heating target is changed) the PLL will lock the phase difference between those two signals and keep the system resonant.

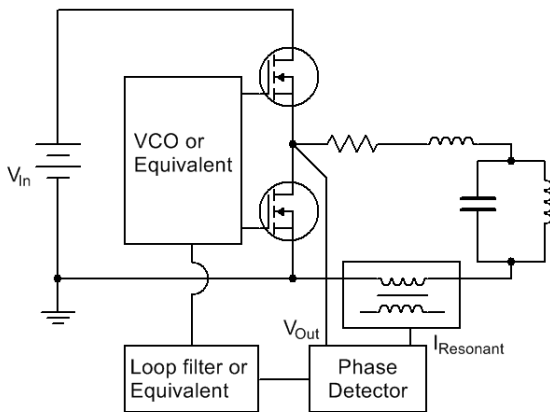

Fig. 2: PLL dominated induction heating system.

Significant research over the years has been carried out on variations to the parameters of PLL systems such as its output frequency, loop bandwidth and lock time [14]. Based on the components used, PLLs can be categorised into three groups. Conventional analogue PLL is the first generation and mainly used in communication systems, where the entire PLL is formed by analogue components [14]. In order to reduce the external components and improve a PLL's tolerance and stability, an all-digital PLL that substitutes function blocks by

digital components has been introduced [15]. The final group is hybrid PLLs, these consist of both analogue and digital function blocks, this providing extra flexibility with optimised hardware cost. A simplified block diagram of a hybrid PLL for induction heating is shown in Fig. 3. In this hybrid system, the traditional VOC has been replaced by an MCU so that a more complex control such as full bridge PWM/PDM with dead time control can be realised.

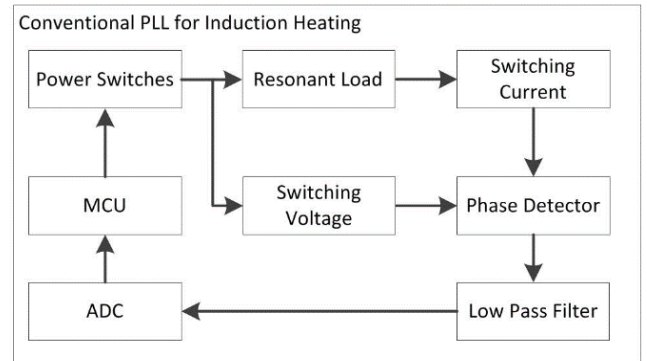

Fig.3. Simplified Block diagram of an induction heating system with hybrid PLL applied.

III. THEORY AND TOPOLOGY OF WIRELESS PLL

As illustrated in Fig. 3, the PLL compensates for the load condition and maintains the converter at its resonant frequency. However, in a wireless power system, the switching frequency of the drive converter should be close to the resonant frequency of the power transmitter, and also equal to the resonant frequency of the power receiver. For the simplified schematic shown in Fig. 4, $F_{SW} = \frac{1}{2\pi\sqrt{L_r * C_r}}$ should be fulfilled in order to achieve maximise transfer efficiency.

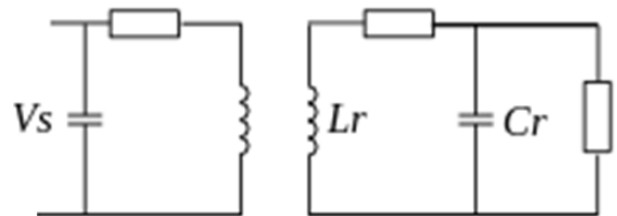

Fig. 4. Simplified schematic of an SCMR based wireless power system.

When implementing a PLL into a wireless power system, the challenge is to how calculate the phase difference. The phase difference is between the transmitting current and receiving voltage and is the key parameter to realise the phase shift control based MEPT. The difficulty is to wirelessly transfer one signal in real time so that those two signals can be analogously or digitally compared without requiring a very high bandwidth communication link. A solution is to realise those operations using data converters, where the transmitting current and receiving voltage are sampled using two commonly clocked data converters. This simplified approach yields the phase difference by comparing the zero-crossing points of those two

sampled data arrays. However, for those two data converters that are located independently in the transmitter and receiver, a wireless common trigger has to be provided. [16]

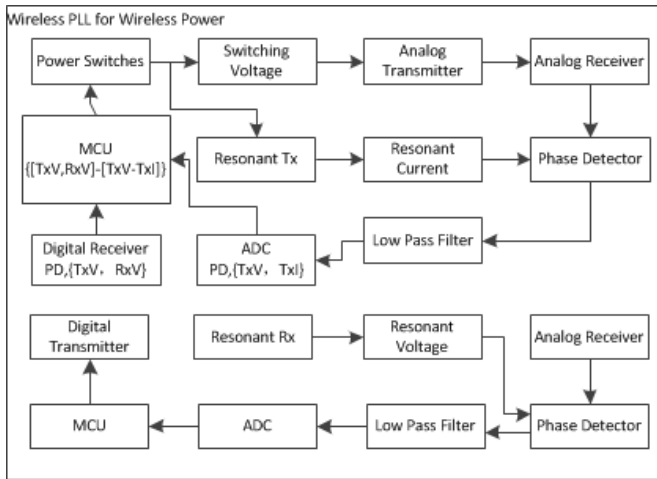

Fig.5. Simplified block diagram of a wireless PLL.

As shown in Fig. 5, to realise the desired wireless PLL without high-speed data converters, a two-stage phase detector can be utilised. Contrasting to a wired phase detector where the phase difference of two signals are compared or triggered directly, a wireless PLL must use a third signal for common reference and calculate the desired phase difference as a two-stage process. The proposed method in this paper utilises the output voltage signal of the primary as this third reference signal. The detailed topology for the transmitter circuit is shown in Fig. 6.

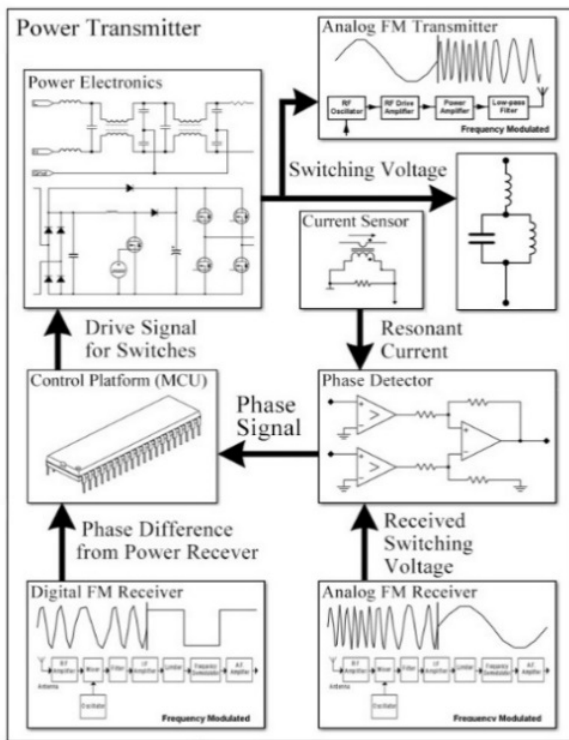

Fig.6. HyWi-FFTPLL on its Transmitter Side.

As shown in Fig. 6, the basic function on the transmitter side compares the phase difference between switching voltage and resonant current, which is similar to the operation of a conventional PLL. Since the switching voltage will also be used on the receiver side, it is also transmitted via an analog transmitter to a receiver on other side. Different from the conventional PLL where the phase between switching voltage and resonant current are compared directly, to remove the propagation delay caused by the analog transmitter, the switching voltage signal is firstly passed through an analog transmitter-receiver bridge. Furthermore, a quantization-subtraction phase detector is used since the HyWi-FFTPLL represents the phase difference on frequency domain instead of time domain.

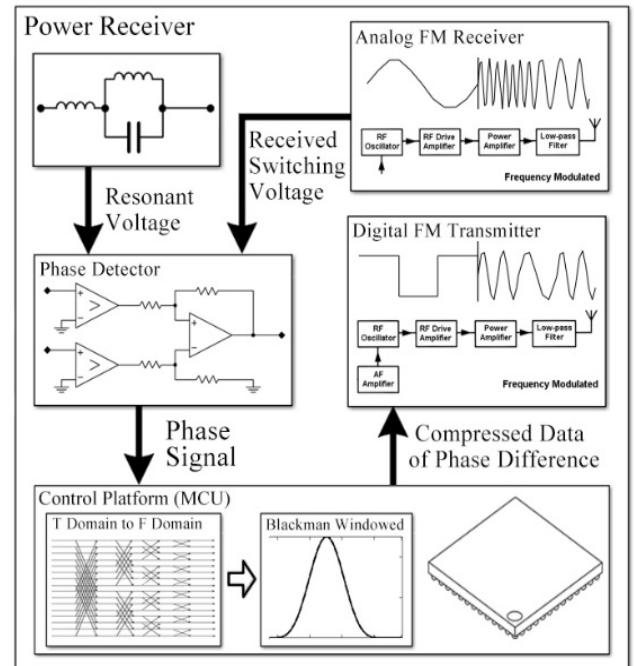

Fig.7. HyWi-FFTPLL on its Receiver Side.

The receiver side of the HyWi-FFTPLL is relatively simple and therefore potentially low cost. As shown in Fig. 7, the receiver side requires an analog receiver where the switching voltage of the transmitter side can be acquired. Meanwhile, the resonant voltage waveform can also be measured from the receiving resonator. The phase difference between the switching voltage and resonant voltage can then be calculated. This result then needs to be relayed back to the power transmitter but requires a high bandwidth. In this paper the phase signal is translated from the time domain to the frequency domain; by removing its higher order harmonic components the amount of data required to be transmitted can be reduced. Furthermore, the frequency domain phase difference is simplified by adding a Blackman or Hanning window. Finally, the desired frequency data can be communicated back to the power transmitting side by using a digital ISM transmitter using a communication link at least 10 times lower in bandwidth than for a time based signal transmission.

IV. SIMULATION

Based on the system topology introduced in the previous section, a Simulink module has been built to verify the design. The simulation diagram is shown in Fig. 8. In the simulation model, waveforms of a simple resonant converter are simulated. The current waveform is generated from a delayed sinewave and the undelayed sinewave is compared with zero so that a corresponding voltage waveform which leads the resonant current can be obtained. The detailed waveform is showing in Fig 9.

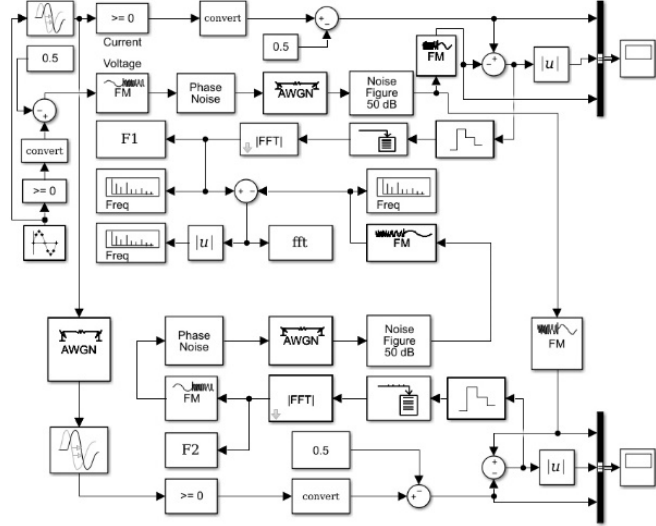

Fig. 8. Simulink schematic of HyWi-FFTPLL.

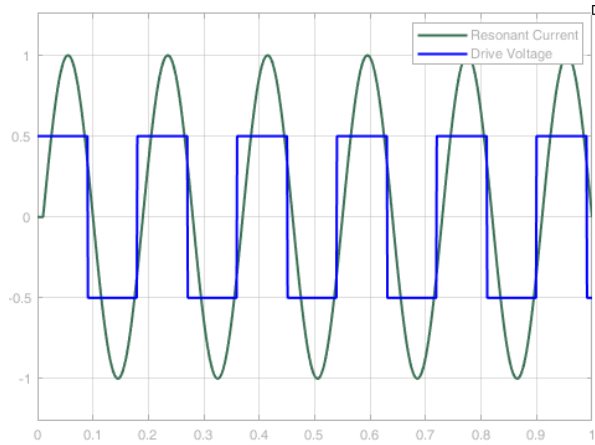

Fig. 9. Simulated waveforms represents the converter

During simulation, the wireless channel of the drive voltage is simulated using an analog FM modulator-demodulator pair with the addition of phase noise, white noise, thermal noise and antenna noise. The waveform of the power transmitter side is shown in Fig. 10. By feeding the phase difference signal into the microcontroller located at the power transmitter, the phase data can be converted into its frequency domain by performing a fast Fourier transform.

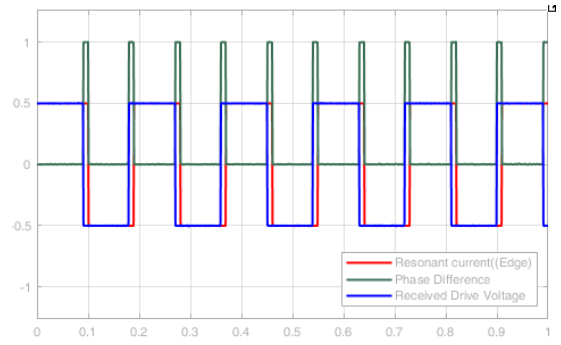

Fig. 10. Simulated transmitting side waveforms.

On the power receiver side, the transmitted voltage signal is simulated by a FM modulator-demodulator pair with the addition of noise as per the transmitter. Meanwhile, the phase difference between the transmitting current and receiving voltage is simulated by adding a transport delay to the transmitting current as the receiving resonator is excited by the transmitting magnetic field, which is in turn excited by transmitting current. Consequently, the phase difference can be obtained by comparing the received drive voltage and the receiving resonant voltage.

The phase difference obtained on the power receiver side will be sampled by the power receiver's on-board microcontroller. By performing a fast Fourier transform, the phase difference in the frequency domain can be obtained. Since the higher order harmonics are not necessary to obtain the amplitude of the phase difference, the amount of data being sent back to the transmitter can be significantly reduced. Finally, the data obtained from the power receiver is transferred back to the power transmitter by using a digital Phase-Shift Keying (PSK) modulator-demodulator pair. On the power transmitter side, the two phase differences in the frequency domain, transmitting current to drive voltage and receiving voltage to drive voltage, are compared. Hence, a spectrum matrix representing the amplitude of the phase difference between transmitting current and receiving voltage can be obtained. Fig. 12 shows the resulting spectrum for different phase shifts between transmitting current and receiving voltage.

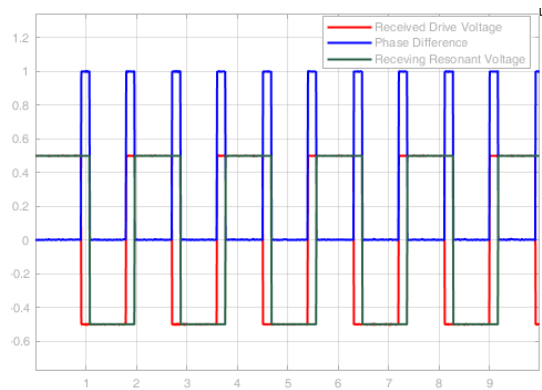

Fig. 11. Simulated receiving side waveforms.

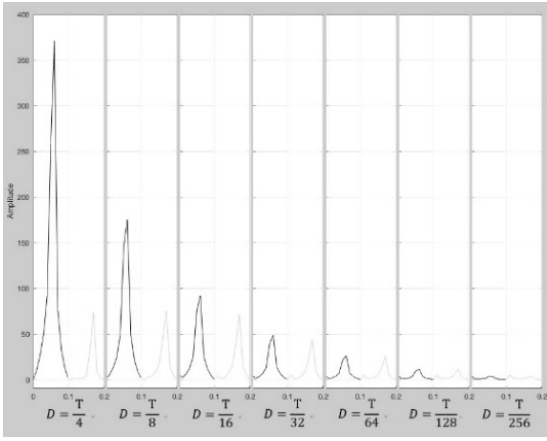

Fig. 12. Spectrum showing amplitudes when phase difference applied.

As illustrated in Fig. 12, the spectrum amplitude follows a downward trend when decreasing the phase shift between transmitting current and receiving voltage. Meanwhile, only a 100 element array of type float is transferred between the power transmitter and power receiver. This model successfully simulates the proposed HyWi-FFTPLL methodology, demonstrating the relatively low bandwidth requirements compared to that of sending sampled waveforms in the time domain.

V. PROTOTYPE DESIGN

A prototype WPT system has been built to evaluate the proposed method as simulated in the previous section. The prototype is designed to deliver up to 300W of power to the load wirelessly. The power transmitter and receiver are shown in Fig. 13 and Fig. 14. The power transmitter is specified to be powered by one or two 12V lead acid batteries. Its on-board microcontroller STM32F334 drives a full bridge consisting of IPT020N10N3 MOSFETs to provided AC output with frequencies between 500 kHz to 1.5MHz. The transmitting current is measured by a 20mΩ shunt resistor and a STM32F030 microcontroller is used to control the analog and digital radio frequency communications.



Fig. 13. Prototype WPT transmitter employing wireless PLL.



Fig 14. Prototype WPT receiver employing wireless PLL.

Based on the topology illustrated in Fig. 6, the practical design for the receiver has been built for evaluation as shown in Fig. 14. The system is designed to utilise the rectified HV DC input from the receiving resonator through an isolated power supply to the deliver the low voltage DC power. A voltage divider is used to measure the receiving voltage. The on board STM32F777 microcontroller samples the receiving voltage together with the analog transmitted drive voltage, so that the phase difference of those signals can be calculated and then the corresponded frequency domain result can be obtained.

VI. TEST AND EVALUATION

The transmitter and receiver prototypes are designed to form a WPT system with fast battery charging abilities. The power transmitting circuitries drives a transmitting coil that central aligned with a corresponded receiving coil. The receiving coil is therefore terminated to the prototype shown in Fig. 14 where the power can be utilised.

Fig. 15 shows the output voltage and current waveform of the drive converter. As can be seen from Fig. 15, the converter can provide desired high-frequency voltage output (blue), which is connected to the transmitting LC resonator, generating a sinusoidal current (purple) which can be quantised to 1-bit data (green).

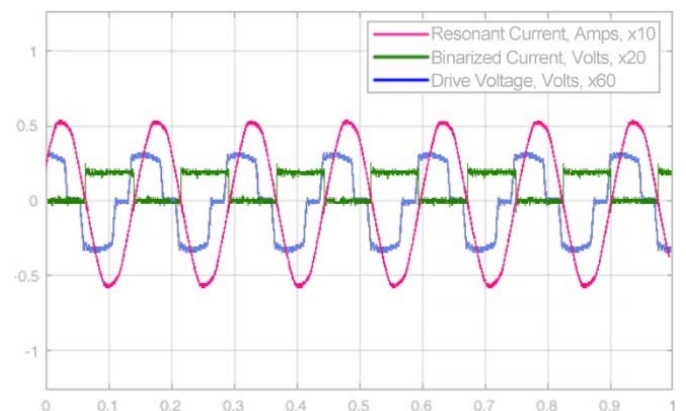

Fig. 15. Output voltage and current waveforms from the power transmitter.

In order to evaluate the wireless PLL methodology introduced in this paper, the transmitting current and receiving voltage are externally measured by an oscilloscope using a current probe and differential probe. By visualising the phase difference between the transmitting current and receiving voltage, the functionality of the wireless PLL can be verified. Since changes in a self-resonant frequency can be difficult to control, changes in self-resonant frequency are performed by connecting several polyester capacitors to the receiving resonator. The additional capacitance pulls the resonant frequency lower than its original. By comparing the phase difference before and after the additional capacitor connected, the performance of wireless PLL can be evaluated.

The results are presented in Fig. 16, the PLL tracks the phase change and controls the output frequency of the transmitting microcontroller. The waveform shows negligible phase difference between transmitting current and receiving voltage. Hence the system efficiency can be maintained.

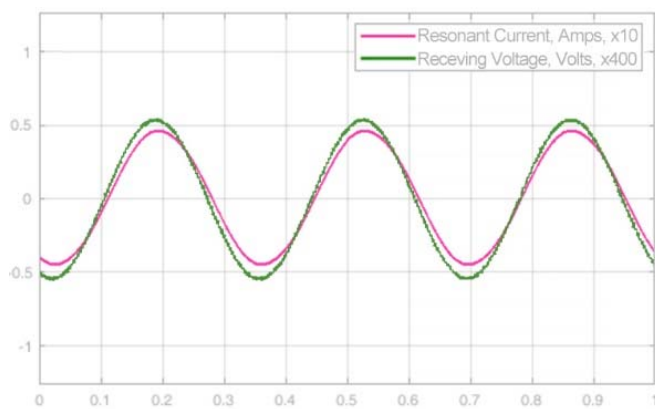

Figure 16: Oscilloscope capture shows the transmitting current and receiving voltage.

VII. CONCLUSION

This paper introduced a novel wireless PLL for WPT system to track the maximum efficiency point. The approach to performing a PLL wirelessly by a two-stage phase detector is demonstrated to be effective. However, to transfer the data generated from the conventional edge-triggered phase detector, a high bandwidth transceiver pair is required. In this research, a FFT dominated method is proposed. The desired method calculates the phase difference using the frequency domain instead of the time domain, and by ignoring the harmonic components the amount of data to be transmitted can further minimised. The desired method has been explored using Simulink and a prototype WPT system has been built for validation. The results presented shown that the phase of transmitter voltage and receiver current can successfully locked, meaning that the maximum efficiency can be achieved under varying load conditions. Hence, a wireless power system implementing the desired wireless PLL methodology could be used in applications with changing environment conditions, coil positions and variable loads.

REFERENCE

- [1] M. Pahlevani and P. Jain, "A fast DC-bus voltage controller for bidirectional single-phase AC/DC converters," *IEEE Trans. Power Electron.*, vol. 30, no. 8, pp. 4536-4547, Aug. 2015.
- [2] D. B. W. Abeywardana, et al., "An input current feedback method to mitigate the DC-side low-frequency ripple current in a single-phase boost inverter," *IEEE Trans. Power Electron.*, vol. 31, no. 6, pp. 4594-4603, Jun. 2016.
- [3] W. L. Ming, et al., "A single-phase four-switch rectifier with significantly reduced capacitance," *IEEE Trans. Power Electron.*, vol. 31, no. 2, pp. 1618-1632, Feb. 2016.
- [4] Andle, Jeffrey C., et al. "Temperature monitoring system using passive wireless sensors for switchgear and power grid asset management." *T&D Asset Management Workshop, MNC-CIGRE/CIRE*. 2010.
- [5] Singh, Rajesh, and Shailesh Mishra. "Temperature monitoring in wireless sensor network using Zigbee transceiver module." *Power, Control and Embedded Systems (ICPCES), 2010 International Conference on.* IEEE, 2010.
- [6] H. Li, et al., "A maximum efficiency point tracking control scheme for wireless power transfer systems using magnetic resonant coupling," *IEEE Trans. Power Electron.*, vol. 30, no. 7, pp. 3998-4008, Jul. 2015.
- [7] Y. Narusue, et al., "Maximum efficiency point tracking by input control for a wireless power transfer system with a switching voltage regulator" *Wireless Power Transfer Conference (WPTC), IEEE, 2015: pp.1-4, 2015.*
- [8] A. P. Sample, et al., "Enabling seamless wireless power delivery in dynamic environments," *Proceedings of the IEEE 101.6*, pp.1343-1358, 2013
- [9] R. Zhao et al., "Maximum efficiency point tracking for resonant wireless power transfer." *Power Electronics, Machines and Drives (PEMD 2016), 8th IET International Conference on. IET, 2016.*
- [10] F. M. Gardner, "Phaselock Techniques, 3rd ed," Hoboken, NJ: Wiley, 2005.
- [11] A. Blanchard, "Phase-Locked Loops: Application to Coherent Receiver Design," New York: Wiley, 1976.
- [12] W. C. Lindsey and C. M. Chie, "A survey of digital phase-locked loops," *Proc. IEEE*, vol. 69, pp. 410-431, Apr. 1981.
- [13] S. Golestan and J.M. Guerrero, "Single-Phase PLLs: A Review of Recent Advances," *IEEE Trans. Power Electronics*, 2017.
- [14] S. Aastha et al., "Designs of all digital phase locked loop." *Engineering and Computational Sciences (RAECS), 2014 Recent Advances in. IEEE, 2014.*
- [15] R. Koushalya, and L. He. "An Innovative Design of ADC and DAC Based Phase Locked Loop." *Proceedings of the World Congress on Engineering. Vol. 1. 2014.*
- [16] R. Zhao et al., "Phase shift control based Maximum Efficiency Point Tracking in resonant wireless power system and its realization." *IECON 2016-42nd Annual Conference of the IEEE. IEEE, 2016.*