



This is a repository copy of *A hybrid stabilization technique for simulating water wave – structure interaction by Incompressible Smoothed Particle Hydrodynamics (ISPH) method.*

White Rose Research Online URL for this paper:
<http://eprints.whiterose.ac.uk/123543/>

Version: Supplemental Material

Article:

Zhang, N., Zheng, X., Ma, Q. et al. (4 more authors) (2018) A hybrid stabilization technique for simulating water wave – structure interaction by Incompressible Smoothed Particle Hydrodynamics (ISPH) method. *Journal of Hydro-environment Research*, 18. pp. 77-94. ISSN 1570-6443

<https://doi.org/10.1016/j.jher.2017.11.003>

Article available under the terms of the CC-BY-NC-ND licence
(<https://creativecommons.org/licenses/by-nc-nd/4.0/>).

Reuse

This article is distributed under the terms of the Creative Commons Attribution-NonCommercial-NoDerivs (CC BY-NC-ND) licence. This licence only allows you to download this work and share it with others as long as you credit the authors, but you can't change the article in any way or use it commercially. More information and the full terms of the licence here: <https://creativecommons.org/licenses/>

Takedown

If you consider content in White Rose Research Online to be in breach of UK law, please notify us by emailing eprints@whiterose.ac.uk including the URL of the record and the reason for the withdrawal request.



eprints@whiterose.ac.uk
<https://eprints.whiterose.ac.uk/>

Figure 1

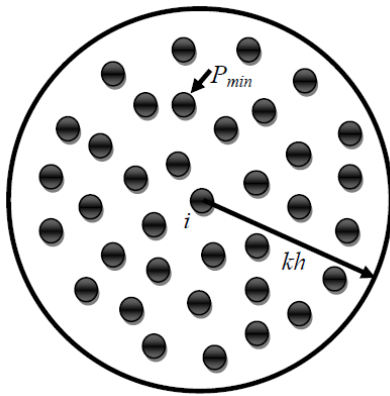

Figure 2

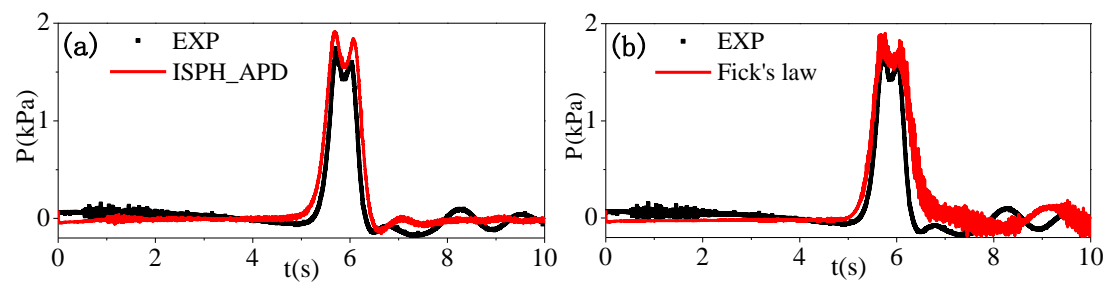

Figure 3

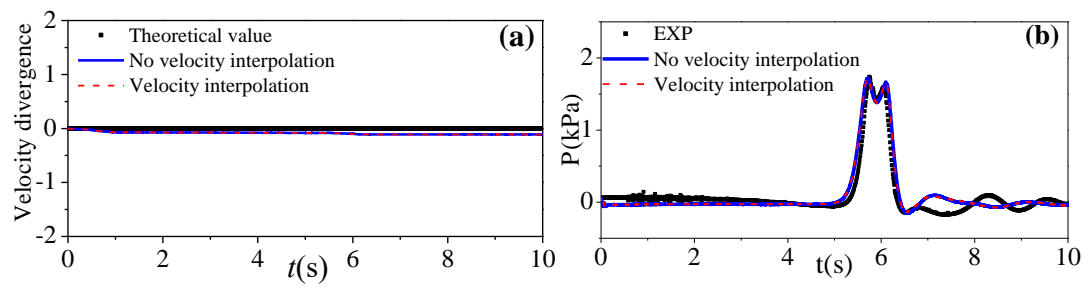

Figure 4

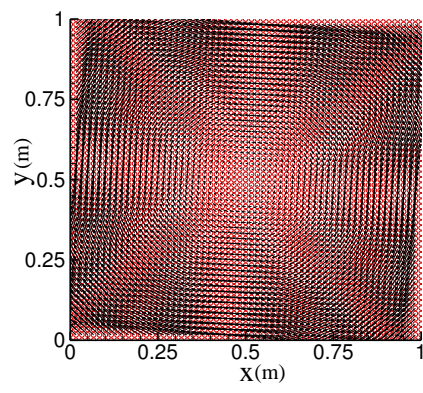
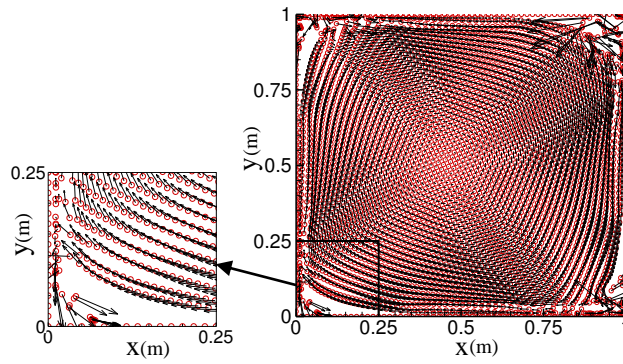
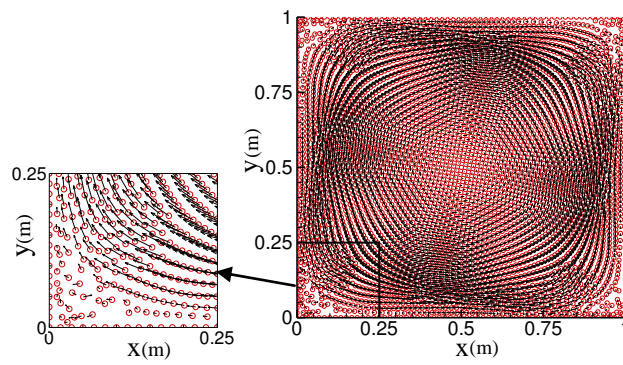

Figure 5



(a) ISPH (diverged at $t = 0.53$ s)



(b) ISPH_APD

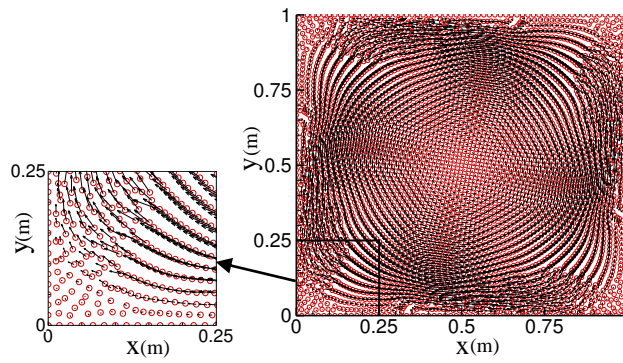

(c) ISPH_MP

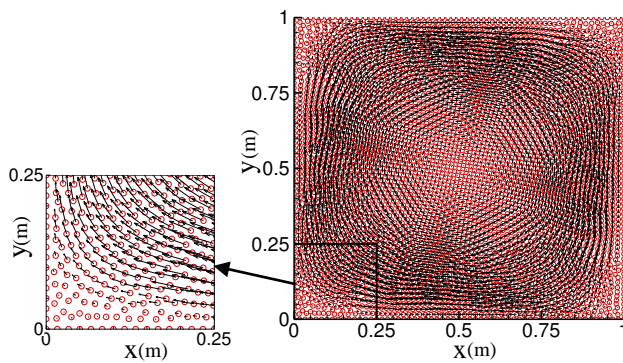

(d) ISPH_MPAPD

Figure 6

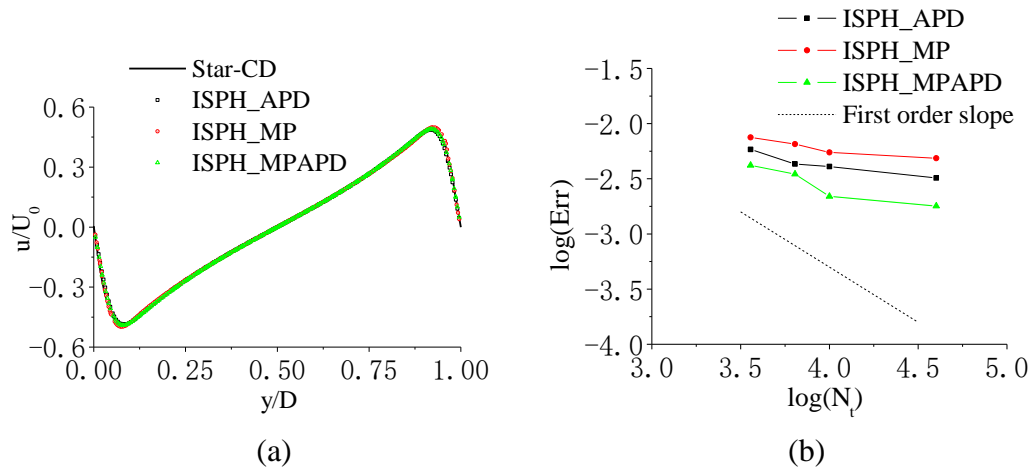

Figure 7

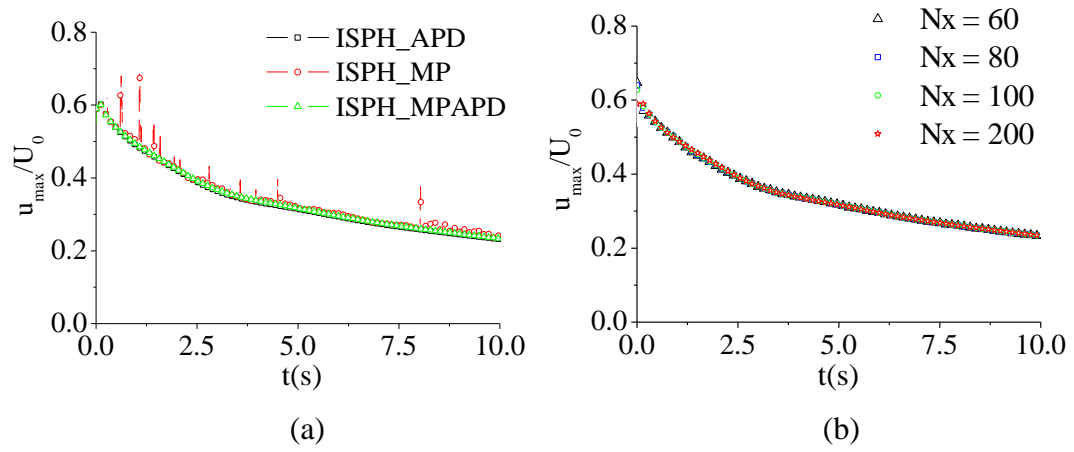

Figure 8

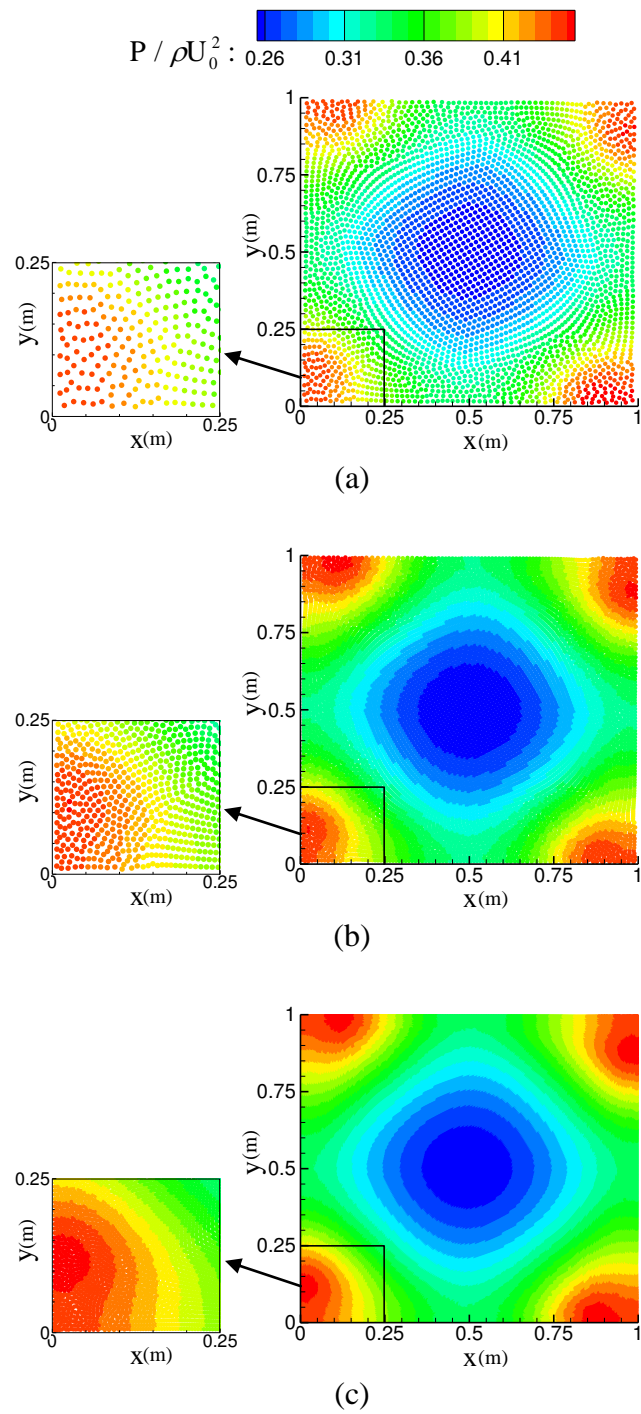

Figure 9

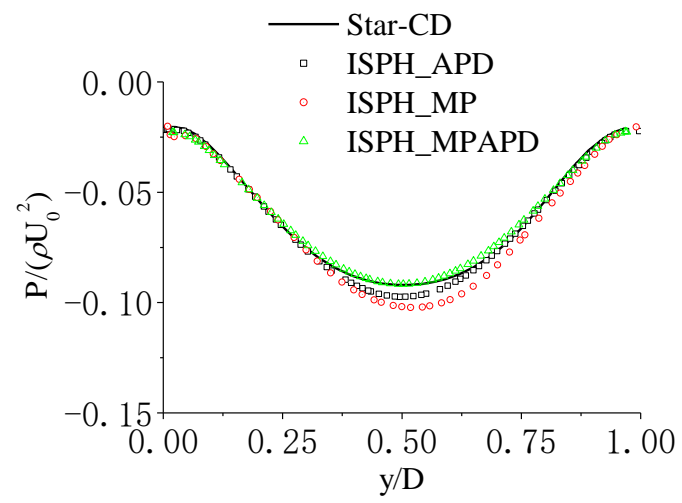

Figure 10

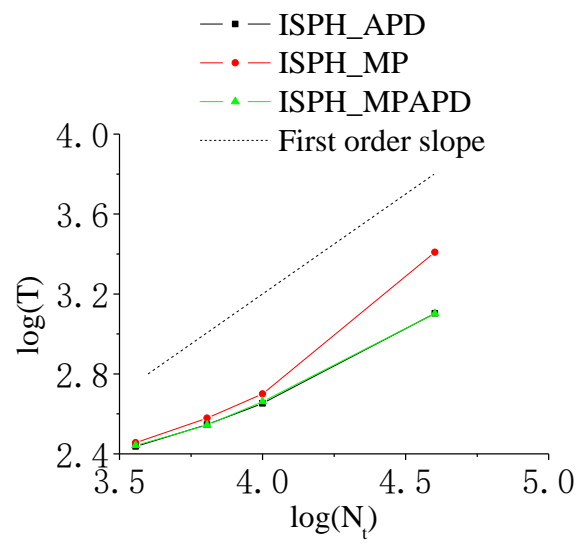

Figure 11

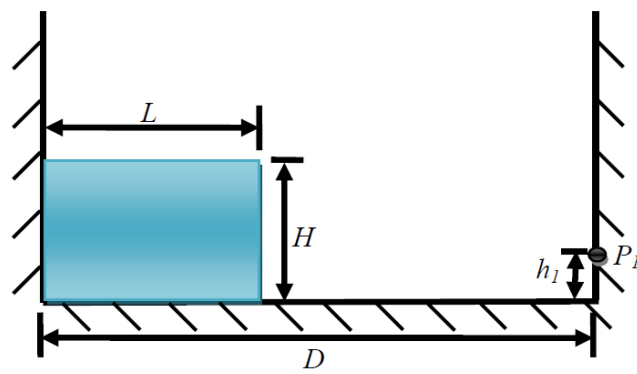

Figure 12

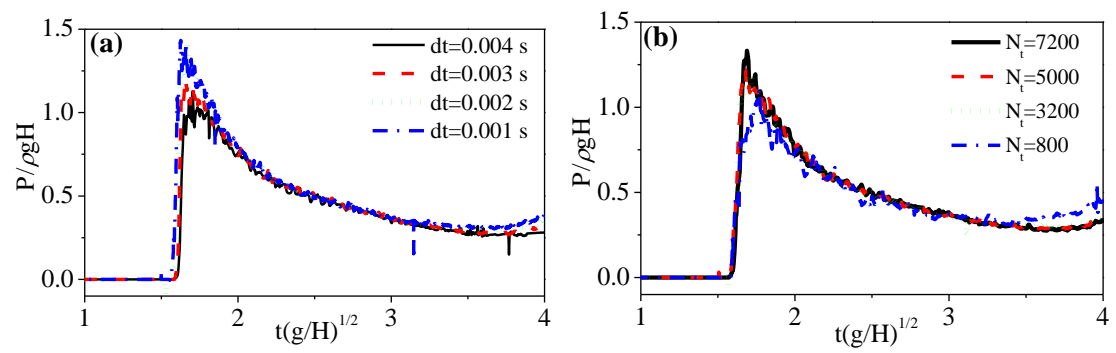

Figure 13

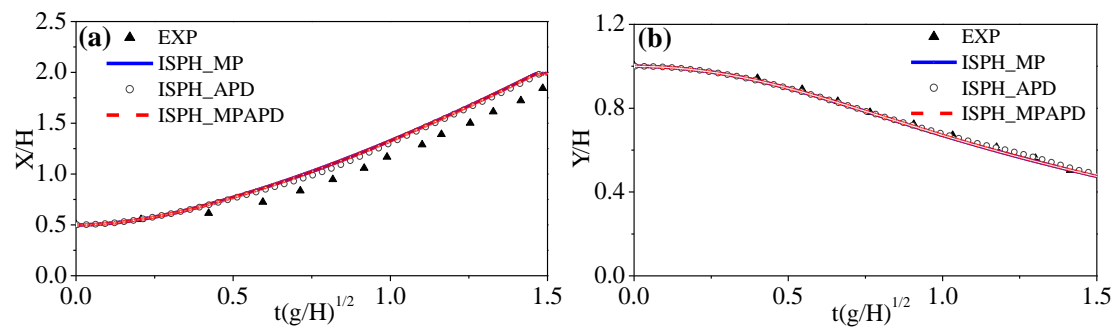

Figure 14

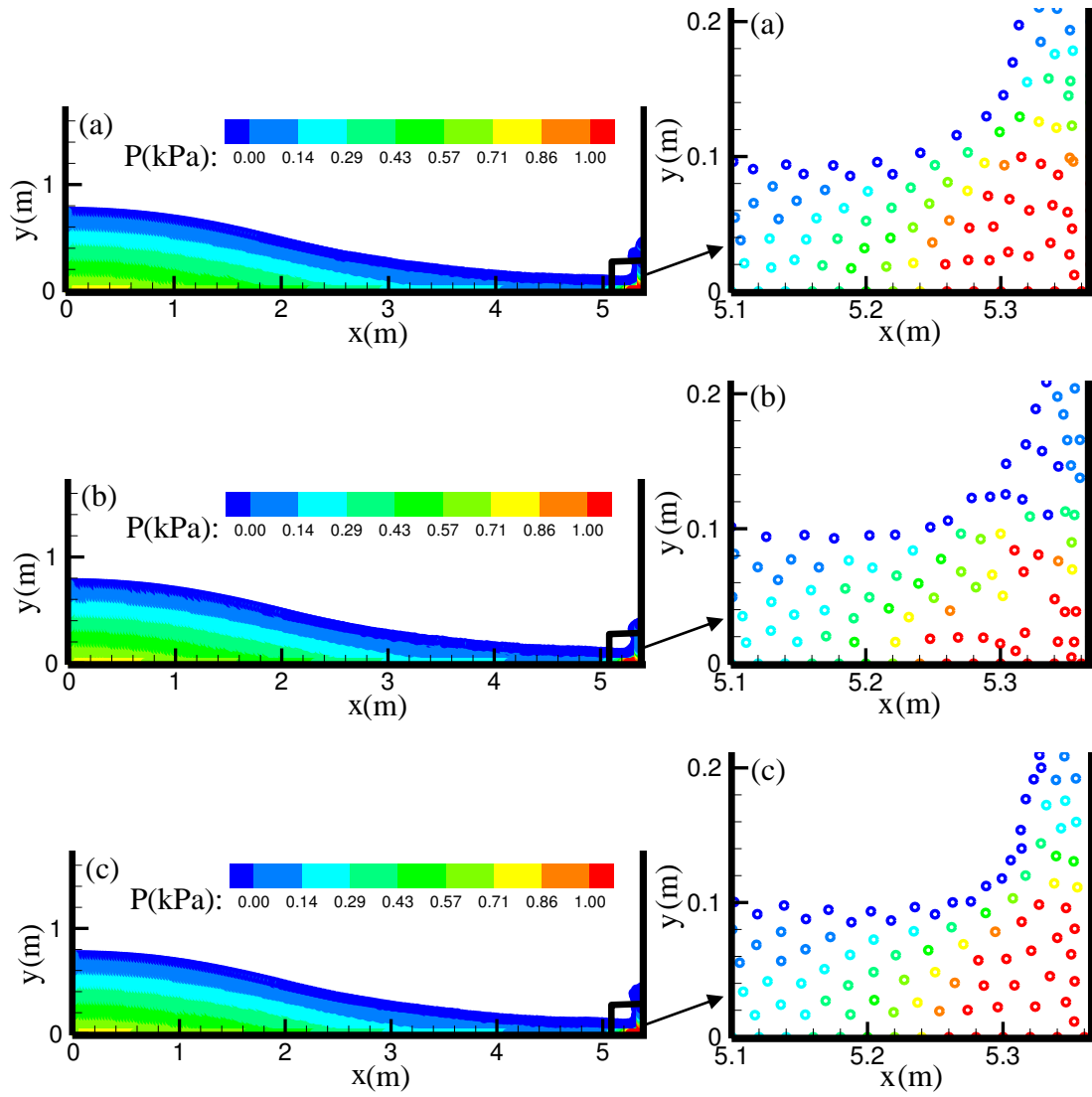

Figure 15

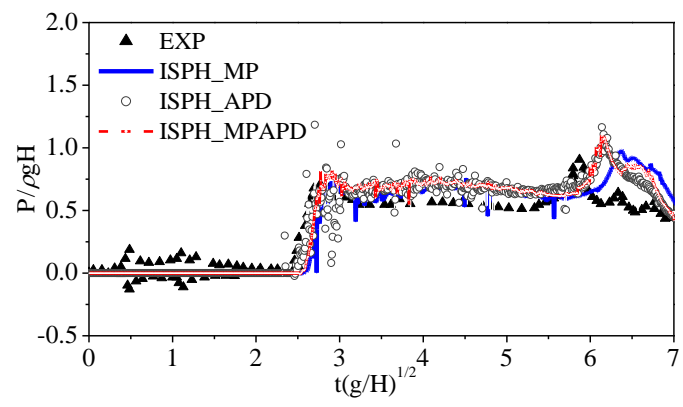

Figure 16

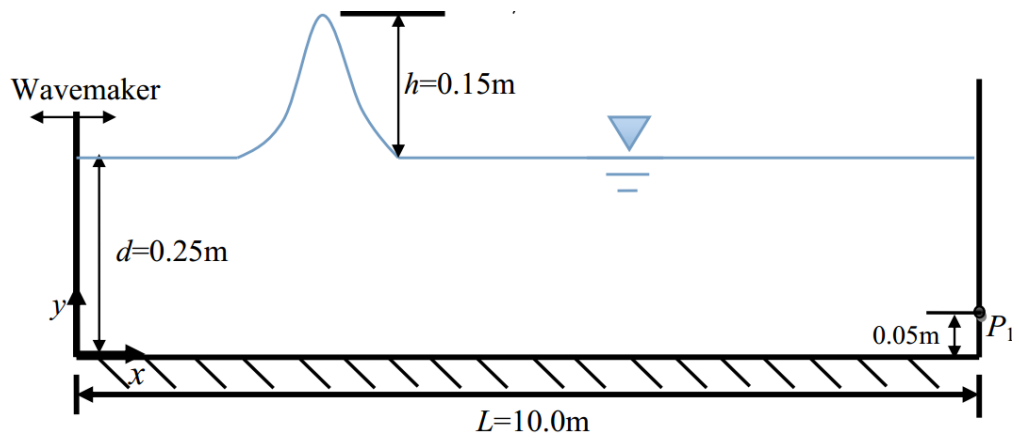

Figure 17

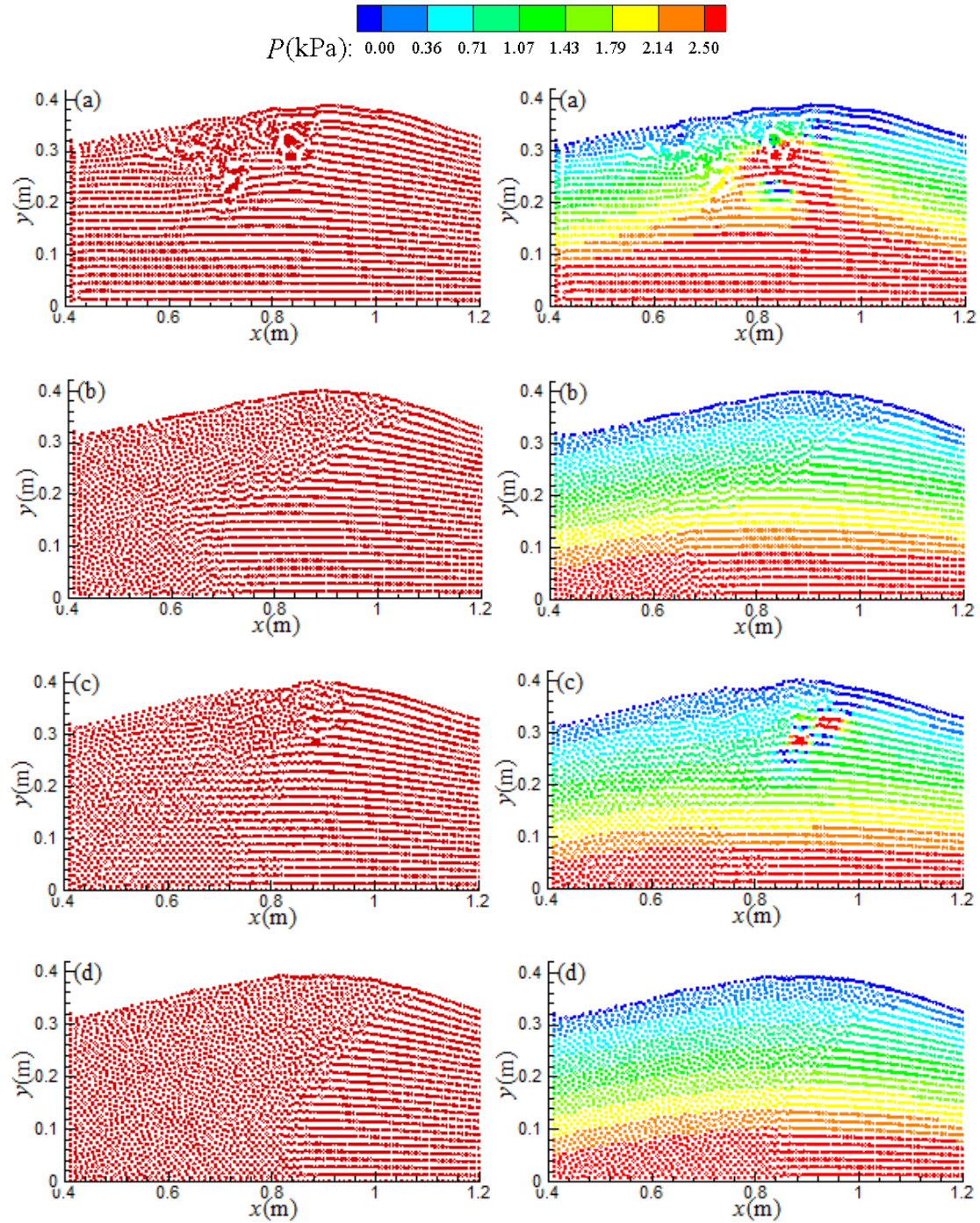

Figure 18

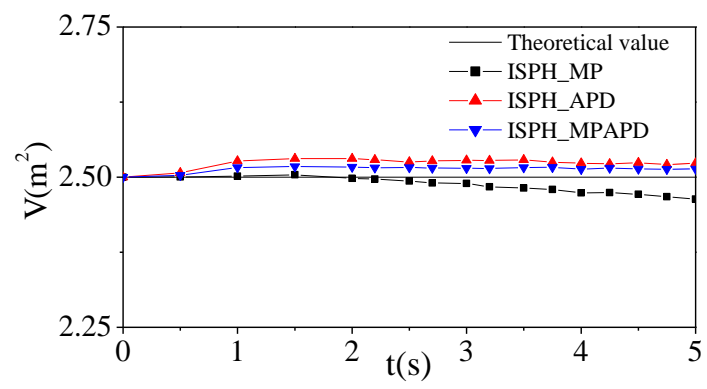

Figure 19

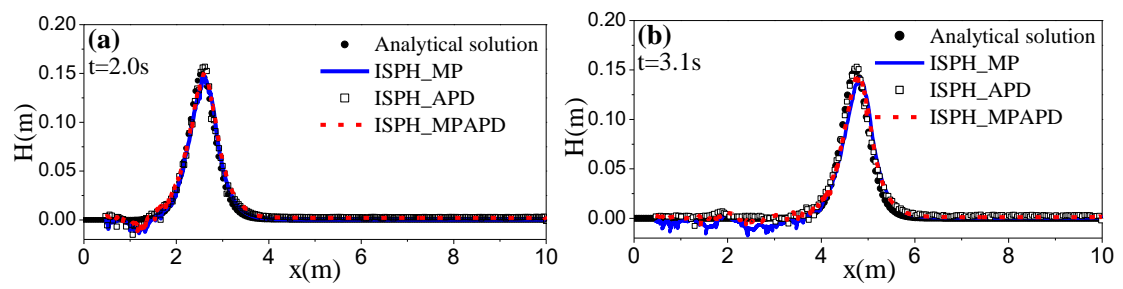

Figure 20

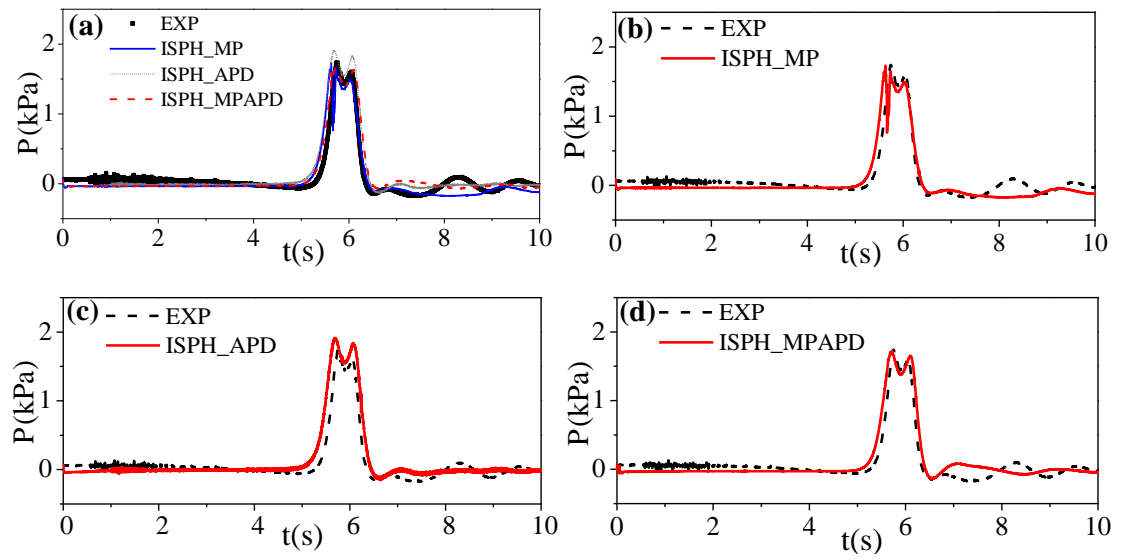

Figure 21

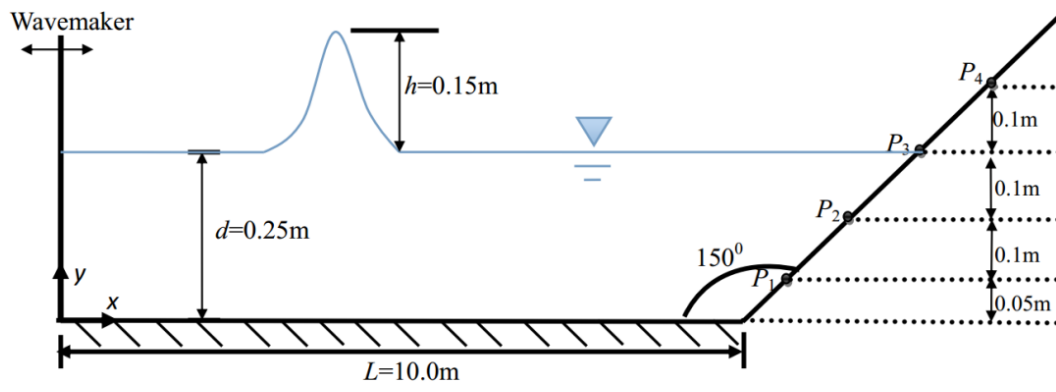

Figure 22

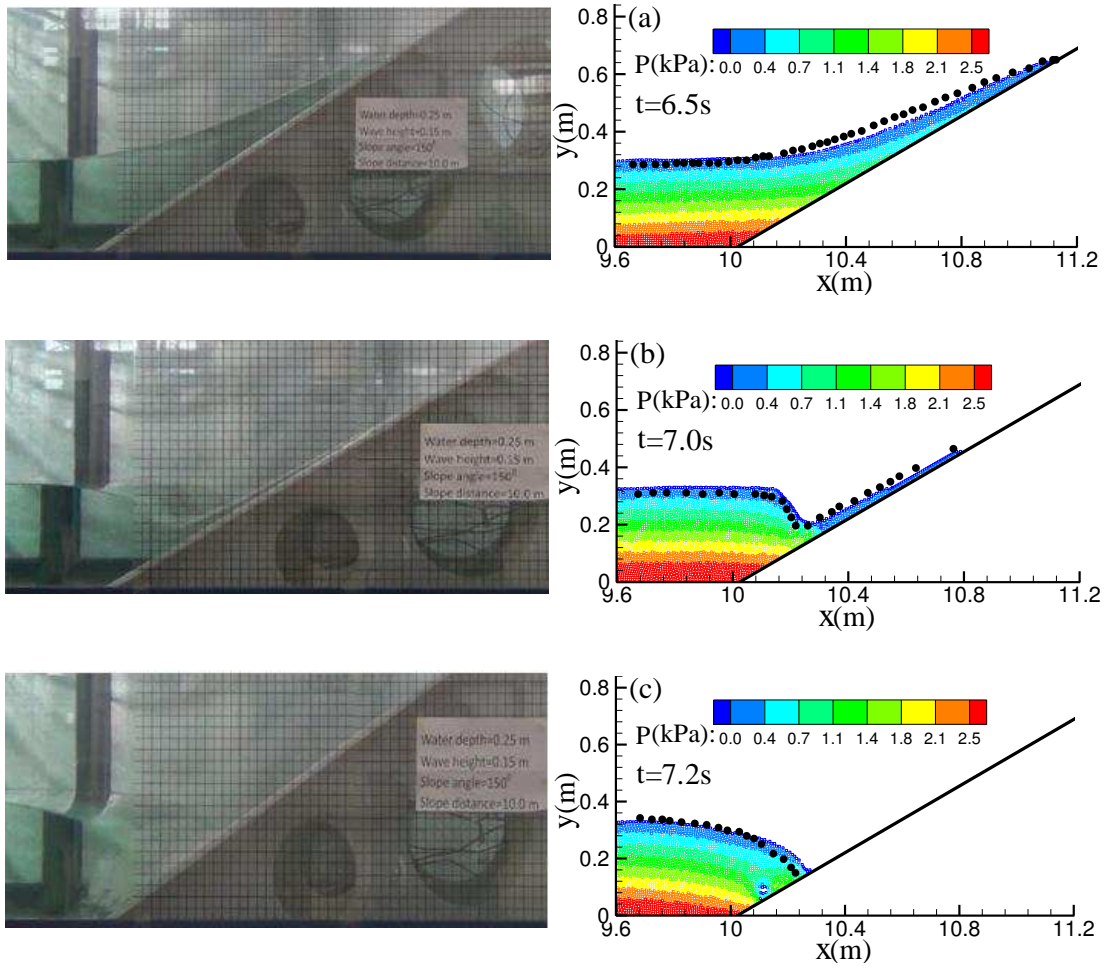

Figure 23

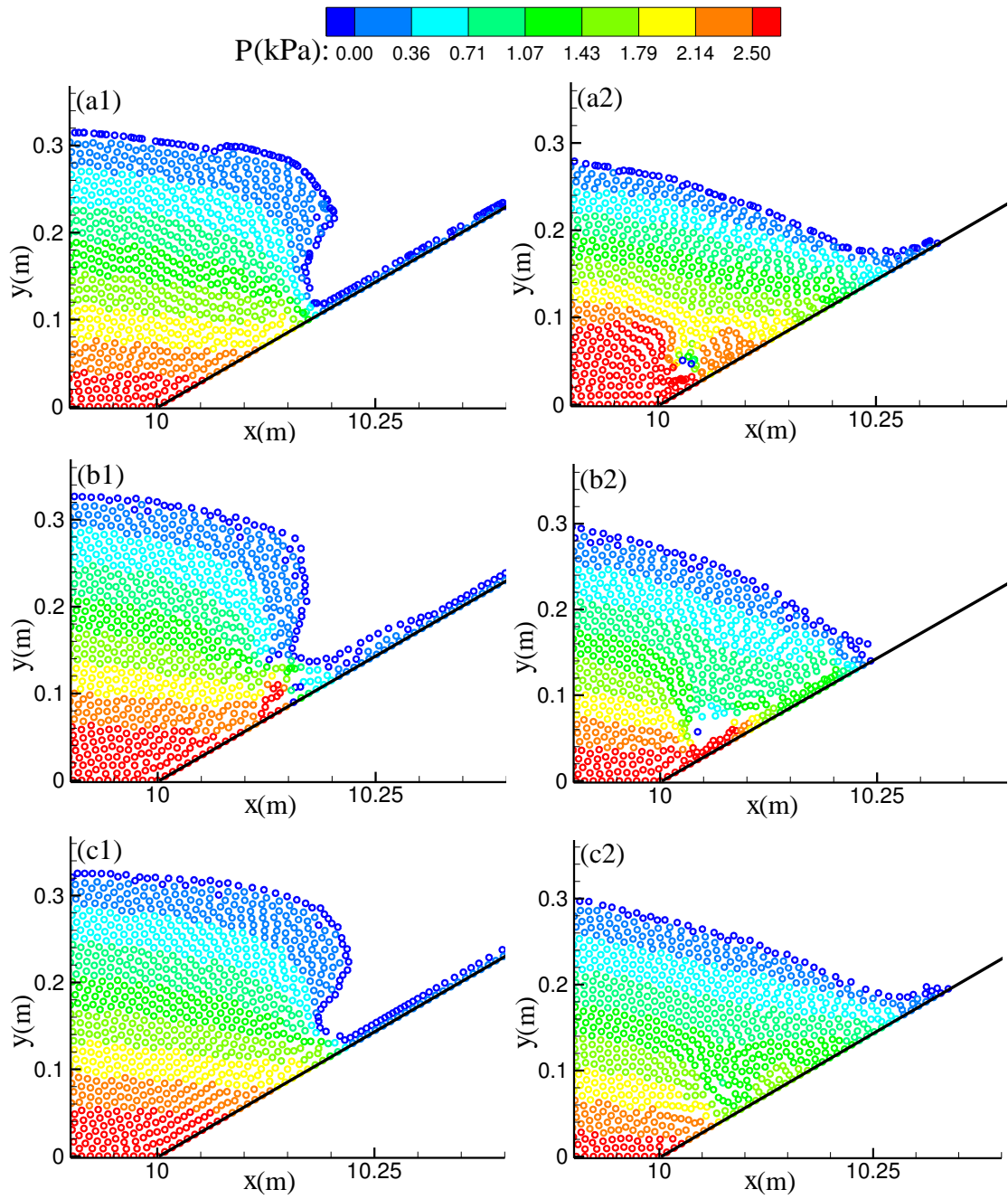

Figure 24

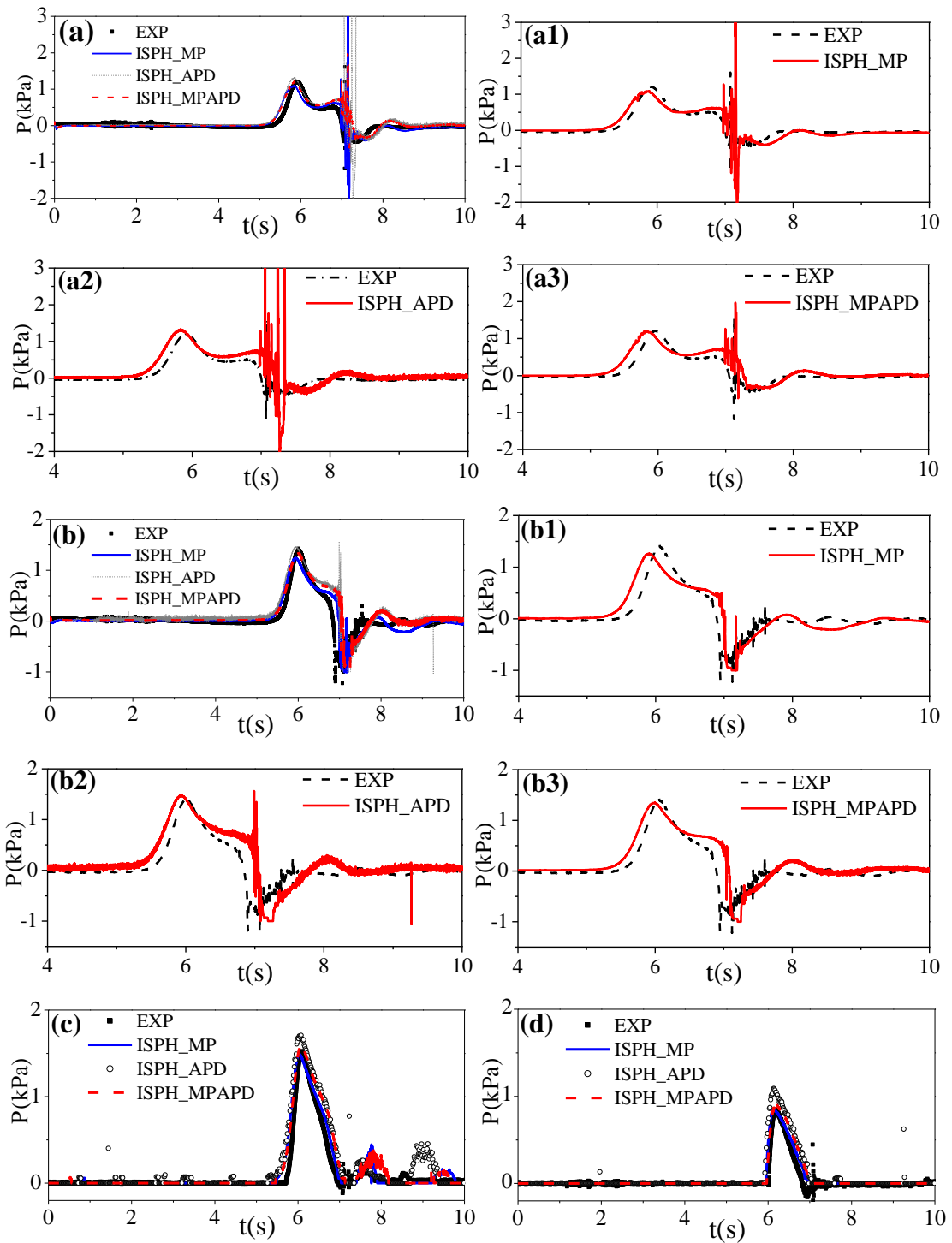

Figure 25

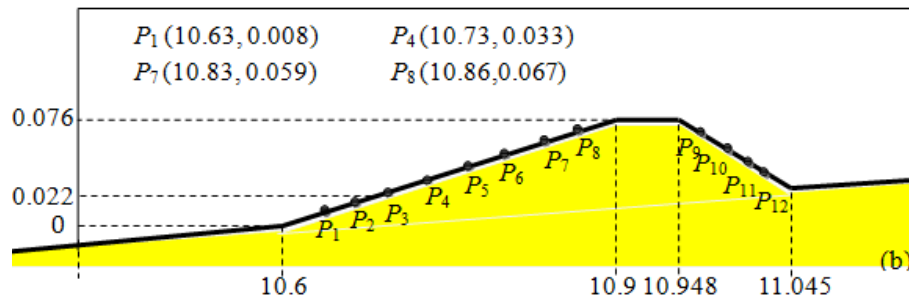
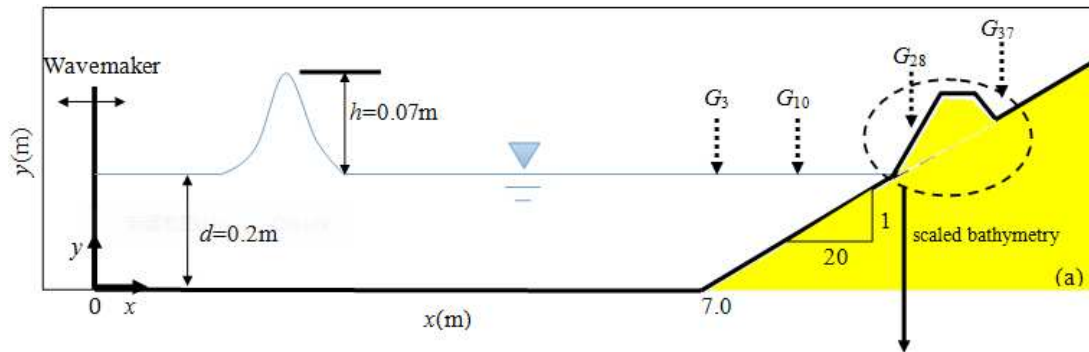

Figure 26

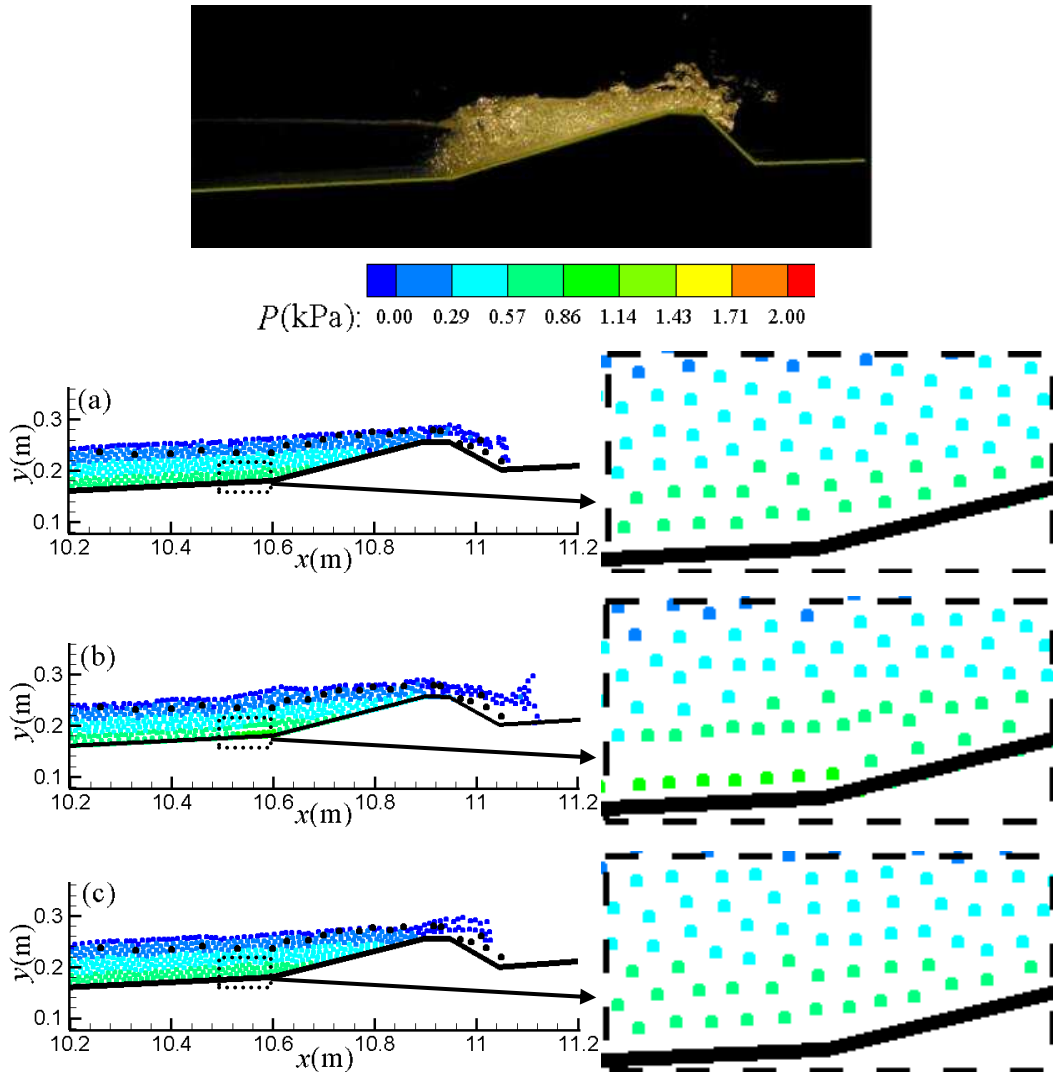

Figure 27

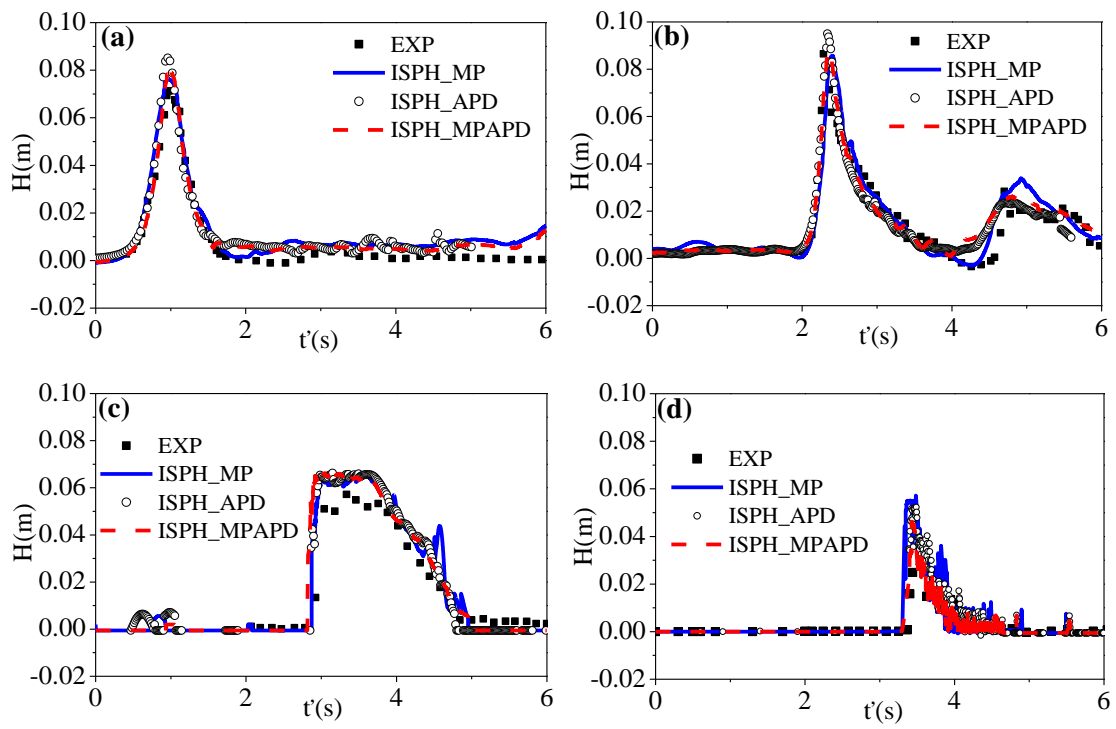

Figure 28

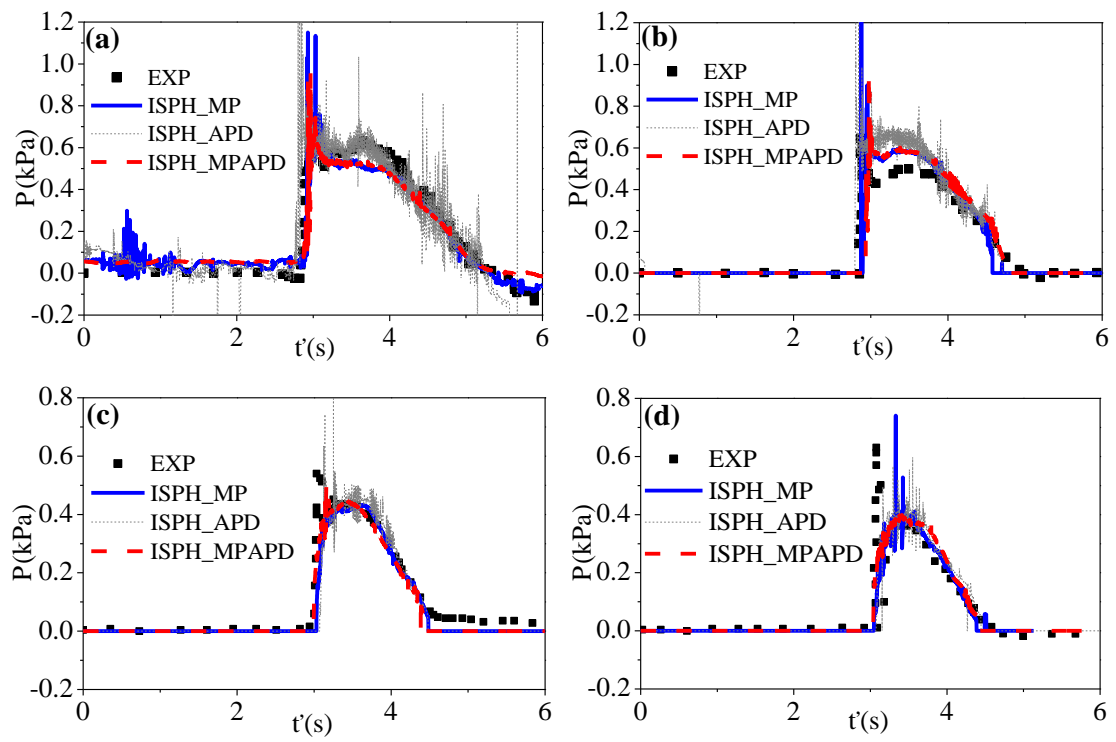

Figure 29

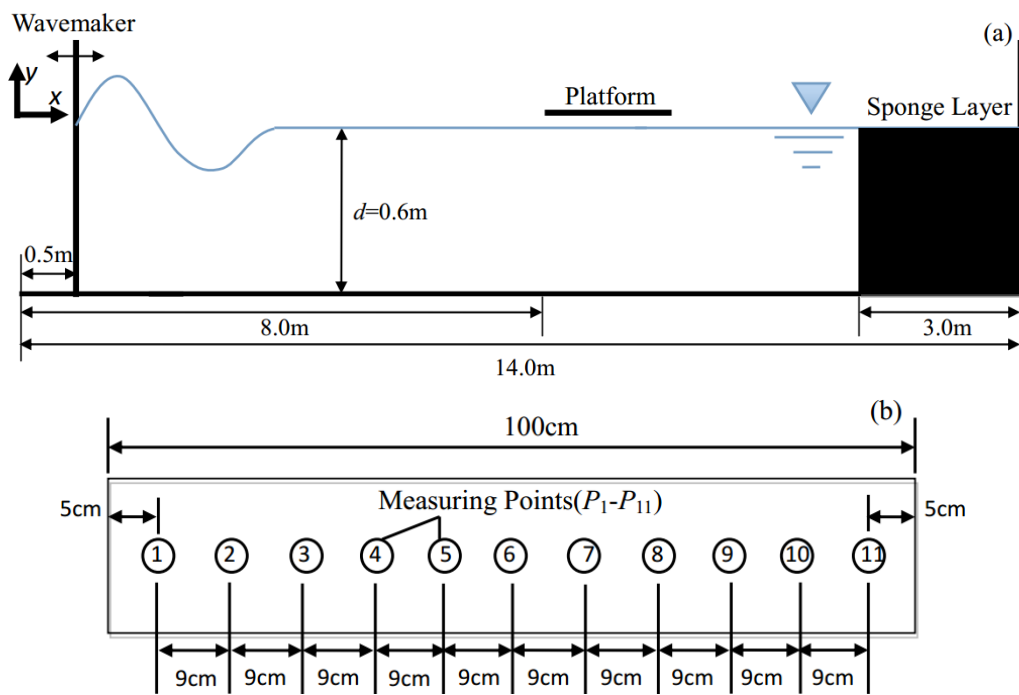

Figure 30

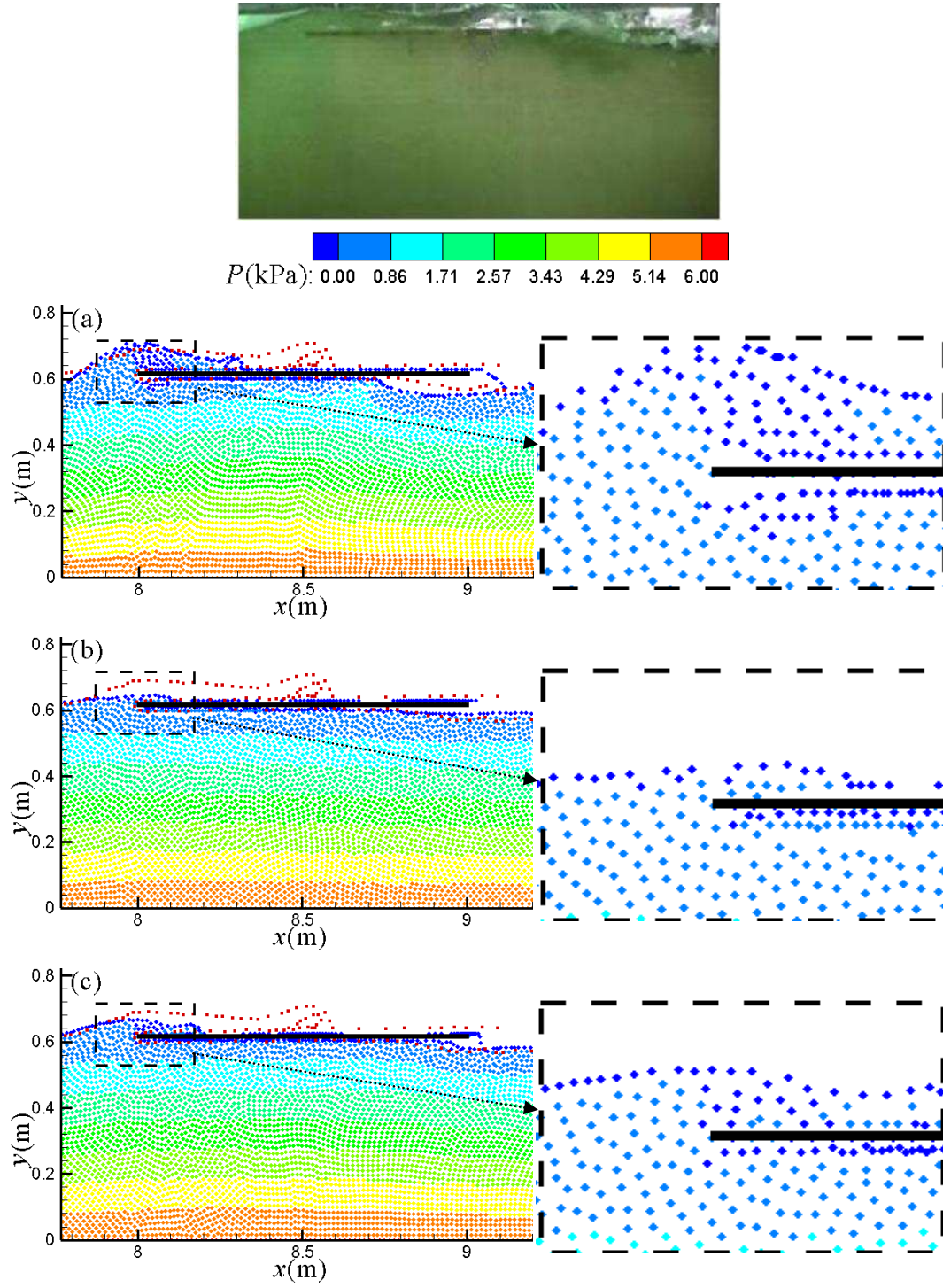

Figure 31

