

This is a repository copy of *Experimental investigations of the sub-Coulomb 12C+12C and 12C+16O reactions*.

White Rose Research Online URL for this paper:

<https://eprints.whiterose.ac.uk/121755/>

Version: Published Version

Article:

Courtin, S., Fruet, G., Jenkins, D. G. orcid.org/0000-0001-9895-3341 et al. (11 more authors) (2017) Experimental investigations of the sub-Coulomb 12C+12C and 12C+16O reactions. *Journal of Physics: Conference Series*. 012049. pp. 1-6. ISSN 1742-6596

<https://doi.org/10.1088/1742-6596/863/1/012049>

Reuse

This article is distributed under the terms of the Creative Commons Attribution (CC BY) licence. This licence allows you to distribute, remix, tweak, and build upon the work, even commercially, as long as you credit the authors for the original work. More information and the full terms of the licence here:

<https://creativecommons.org/licenses/>

Takedown

If you consider content in White Rose Research Online to be in breach of UK law, please notify us by emailing eprints@whiterose.ac.uk including the URL of the record and the reason for the withdrawal request.

PAPER • OPEN ACCESS

Experimental investigations of the sub-Coulomb $^{12}\text{C}+^{12}\text{C}$ and $^{12}\text{C}+^{16}\text{O}$ reactions

To cite this article: S Courtin *et al* 2017 *J. Phys.: Conf. Ser.* **863** 012049

View the [article online](#) for updates and enhancements.

Related content

- [\$^{12}\text{C}+^{12}\text{C}\$ fusion in a multichannel folding model](#)
M Assunção and P Descouvemont
- [Search for electromagnetic transitions between molecular states : results from the radiative capture channel](#)
Sandrine Courtin
- [Search for \$^{28}\text{Si}\$ cluster states through the \$^{12}\text{C}+^{16}\text{O}\$ radiative capture](#)
S Courtin, A Goasduff, F Haas et al.

Experimental investigations of the sub-Coulomb $^{12}\text{C}+^{12}\text{C}$ and $^{12}\text{C}+^{16}\text{O}$ reactions

S Courtin^{1,2,3}, G Fruet^{1,2}, D G Jenkins⁴, C L Jiang⁵, M Heine^{1,2}, D Montanari^{1,2,3},
D Santiago-Gonzalez⁵, M Avila-Coronado⁵, L G Morris⁴, A Goasduff⁶, E Rehm⁵,
B Back⁵, D Bourgin^{1,2} and C Beck^{1,2}

¹ IPHC, Université de Strasbourg, F-67037 Strasbourg, France

² CNRS, UMR7178, F-67037 Strasbourg, France

³ USIAS, F-67083 Strasbourg, France

⁴ Department of Physics, University of York, Heslington, York YO10 5DD, UK

⁵ Physics Division, Argonne National Laboratory, Argonne IL 60439, USA

⁶ INFN Laboratori Nazionali di Legnaro, I-35020 Legnaro (Padova), Italy

E-mail: Sandrine.Courtin@iphc.cnrs.fr

Abstract. Cluster resonances in light heavy-ion systems like $^{12}\text{C}+^{12}\text{C}$ and $^{12}\text{C}+^{16}\text{O}$ may have a major impact on astrophysics stellar scenarios. Resonant radiative capture reactions have been studied for these systems at energies at and slightly below their Coulomb barriers to investigate the possible $^{12}\text{C}-^{12}\text{C}$ and $^{12}\text{C}-^{16}\text{O}$ molecular origin of the resonances. Spins have been attributed to the resonances and specificities of their γ -decay have been identified. At deep sub-barrier energies, a fusion cross section measurement using the particle- γ coincidence technique is discussed for the $^{12}\text{C}+^{12}\text{C}$ system. A new project is presented to possibly extend the $^{12}\text{C}+^{12}\text{C}$ S low-energy S factor study.

1. Introduction

Alpha cluster configurations are features of light nuclei, known to occur close to their α decay thresholds as proposed by H. Horiuchi in the late 1960s [1]. From the theoretical point of view, the cluster nature of a nuclear state could be characterized by the projection of the state wave function onto a cluster subspace, part of the full space used to describe the state, in a spectroscopic factor picture. From the experimental point of view, the cluster nature of a nucleus can be related to: *i.* its fragmentation properties into alpha or multiples of alpha substructures, *ii.* its γ decay, specific of a highly deformed structure [2].

The first part of this contribution concerns the γ decay of cluster resonances in the $^{12}\text{C}+^{12}\text{C}$ and $^{12}\text{C}+^{16}\text{O}$ systems in reactions close to the Coulomb barrier (CB).

The second part will focus on measurements of fusion cross sections at deep sub-barrier energies in the $^{12}\text{C}+^{12}\text{C}$ system. Such cross sections are related to nuclear astrophysics since the ^{12}C burning is an important feature of the evolution of massive stars and the associated nucleosynthesis. The $^{12}\text{C}+^{12}\text{C}$ reaction is known to be highly resonant from energies at the CB to a few MeV per nucleon. These resonances have been discussed in terms of molecular configurations in ^{24}Mg . Interestingly enough, such configurations have been predicted down to the Gamow window [3] but not yet observed directly.



The last part of this contribution will discuss the STELLA project which aims at measuring sub-barrier fusion cross sections of astrophysical interest in systems for which cluster resonances have been identified.

2. Radiative capture reactions in the $^{12}\text{C}+^{12}\text{C}$ and $^{12}\text{C}+^{16}\text{O}$ systems

The $^{12}\text{C}+^{12}\text{C}$ and $^{12}\text{C}+^{16}\text{O}$ radiative capture reactions have been performed at Triumf (Vancouver) using the Dragon spectrometer to select the compound nucleus at 0° [4-6], on resonances previously observed by Sandorfi et al. in the 1980s [7]. A study of the γ decay of resonances around the Coulomb barrier, in an entrance region with $E_{\text{c.m.}}$ ranging from 6 to 9 MeV has been performed for both systems using the Triumf (Vancouver, Canada) BGO array. Results of this campaign are summarized in Table 1. Spins of the populated resonances have been attributed by measuring γ angular distributions. These are in good agreement with previous fusion data. Measurements have been performed on and off resonance. For both systems, enhanced feeding of deformed states of ^{24}Mg and ^{28}Si has been observed at bombarding energies on resonance. At the lowest bombarding energy, for both systems, an enhanced feeding of T=1 states has been observed. A possible interpretation could be that the giant quadrupole resonance (GQR) is excited, built on the ^{24}Mg prolate ground state for $^{12}\text{C}+^{12}\text{C}$ and on the prolate excited band in the case of $^{12}\text{C}+^{16}\text{O}$. In fact, excitation energies in the compound nuclei ^{24}Mg and ^{28}Si , corresponding to the radiative capture at the CB are rather large (20 to 25 MeV). These excitation energies fall into the range of giant quadrupole resonances (GQR). For example, the experimental maximum of the GQR in ^{28}Si is at 18.8 MeV [8], the GQR built on the prolate band of ^{28}Si (starting at 6.7 MeV) would thus lie around 25.5 MeV. Interestingly enough, in ^{28}Si , the B(M1) values extracted from our experimental data for the transition from the resonance to the T = 1 states are around 1.25 W.u., among the strongest measured in this mass region [9].

System	$^{12}\text{C}+^{12}\text{C}$			
$E_{\text{c.m.}}$ (MeV)	8	7.5	6.8	6
Measured J^π	4^+-2^+	4^+	0^+-2^+	2^+
Specificities of the decay	Enhanced feeding of deformed states			Enhanced feeding of 1^+ T=1 states
System	$^{12}\text{C}+^{16}\text{O}$			
$E_{\text{c.m.}}$ (MeV)	9	8.8	8.5	6.6
Measured J^π	6^+	5^-	5^-6^+	2^+
Specificities of the decay	Enhanced feeding of deformed states			Enhanced feeding of 2^+ and 1^+ T=1 states B(M1) \sim 1.25 W.u.

Table 1. : Summary of the results of the Triumf $^{12}\text{C}+^{12}\text{C}$ and $^{12}\text{C}+^{16}\text{O}$ radiative capture campaign (see text).

At lower energies, the $^{12}\text{C}+^{12}\text{C}$ fusion reaction has strong synergies with astrophysics; it plays a crucial role in several scenarios like the formation of white dwarfs, the nucleosynthesis in massive stars and their further evolution, the C ignition in type Ia supernovae, and in suberbusts of neutron stars [10]. Stellar temperatures imply that Gamow energies for light heavy-ion fusion reactions are far below the corresponding Coulomb barriers. The associated cross sections are therefore as small as the sub-nanobarn range, making direct experimental investigations very challenging.

3. Fusion cross sections in the $^{12}\text{C}+^{12}\text{C}$ system

The $^{12}\text{C}+^{12}\text{C}$ fusion reaction has been the object of a realm of experimental investigations in the past [11-17]. The lowest-energy measured resonance in this reaction is at $E_{\text{c.m.}} = 2.1$ MeV [16], only

partially overlapping with the high-energy part of the Gamow window ($E_{\text{Gamow}} = 1.5$ MeV at $T = 10^7$ K). Techniques used to measure the $^{12}\text{C}+^{12}\text{C}$ S factors were based on the detection of particles, i.e. p and α from the $^{12}\text{C}(^{12}\text{C},\text{p})^{23}\text{Na}$ and $^{12}\text{C}(^{12}\text{C},\alpha)^{20}\text{Ne}$ channels respectively, or the detection of γ -rays from the ^{23}Na and ^{20}Ne evaporation residues. All these experiments were subject to large backgrounds from hydrogen or deuterium contaminations of the target, proton and deuteron recoil particles, which could explain some deviations in the experimental results.

Recently, C.L. Jiang et al. proposed to overcome the problem by using a particle- γ coincidence technique, allowing almost no-background measurements [18]. This technique was used to revisit the $^{12}\text{C}+^{12}\text{C}$ low-energy fusion reaction at the Argonne National Laboratory using the Gammasphere large volume germanium array for γ detection in coincidence with particles detected in 3 annular double-sided silicon strip detectors of type S1 and S2 from MICRON, covering $\sim 20\%$ of 4π [19]. The corresponding bombarding energies are $E_{\text{Lab}} = 9.74, 8.56, 7.01$ and 6.06 MeV. The results are reported in Fig. 1 (red circles), along with results from previous campaigns and extrapolations of the S factors

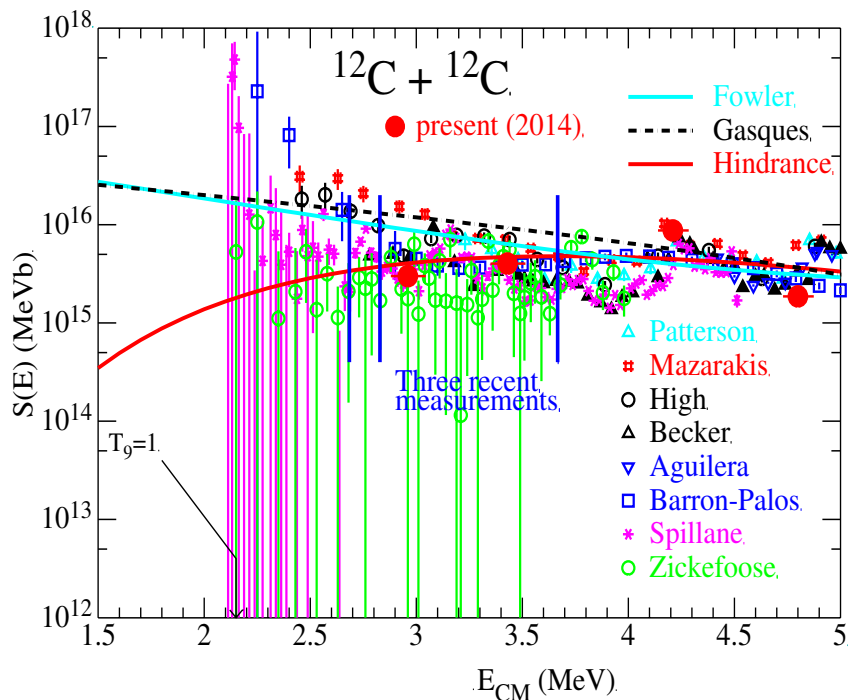

to low energies. A new Gammasphere $^{12}\text{C}+^{12}\text{C}$ experiment was performed very recently using the same set-up (Feb. 2016). The corresponding energies are reported on the Figure with vertical blue lines (three recent measurements). The analysis of this last run is under progress.

Fig. 1: Experimental S factors for $^{12}\text{C}+^{12}\text{C}$. The present results are indicated with red circles. Previous data is taken from Ref. [11-17].

It can be noticed that the technique allows to considerably reduce the data error bars. Yet at low energies, all extrapolations are still compatible with existing experimental data. These extrapolations show more than an order of magnitude differences in the astrophysics region ($< E_{\text{c.m.}} = 2.5$ MeV). The extrapolation indicated by the red line accounts for fusion hindrance effects which have been observed in deep sub-barrier fusion reactions in medium mass systems [20], which could also play a role in the light systems of astrophysics interest. Moreover it should be noted that molecular resonances could be present in this region, and could impact the stellar evolution scenarios.

There would be considerable value in pursuing experimental investigations of the $^{12}\text{C}+^{12}\text{C}$ reaction using the particle- γ coincidence technique, possibly with high beam intensities. Such a project will be briefly described in the next part of this contribution.

4. Perspectives and future projects

The STELLA project (STELLar LABoratory) has been developed to investigate fusion cross sections of astrophysics relevance, hindrance effects and eventual molecular resonances in light heavy-ion systems like $^{12}\text{C}+^{12}\text{C}$, $^{12}\text{C}+^{16}\text{O}$, $^{16}\text{O}+^{16}\text{O}$.

The project will use the particle- γ coincidences technique. Alpha and proton channels will be identified in double-sided silicon strip detectors in coincidence with γ -rays in 1.5''x2.0'' (diameterx length) LaBr₃ scintillators in a compact configuration. Details on the γ detectors can be found in Ref. [21]. Efficiency simulations for the γ array in this configuration are presented in Ref. [22]. The setup is presented in Fig. 2. The STELLA mobile station will be installed for its 1st Phase in 2016-2017 at the Andromede 4 MV NEC Pelletron® electrostatic single stage accelerator in Orsay (France) and will make use of high intensity beams ($I > 1 \mu\text{A}$) [23,24]. A fast rotating target system has been developed to allow heat dissipation in the ^{12}C target and to sustain high beam intensities.

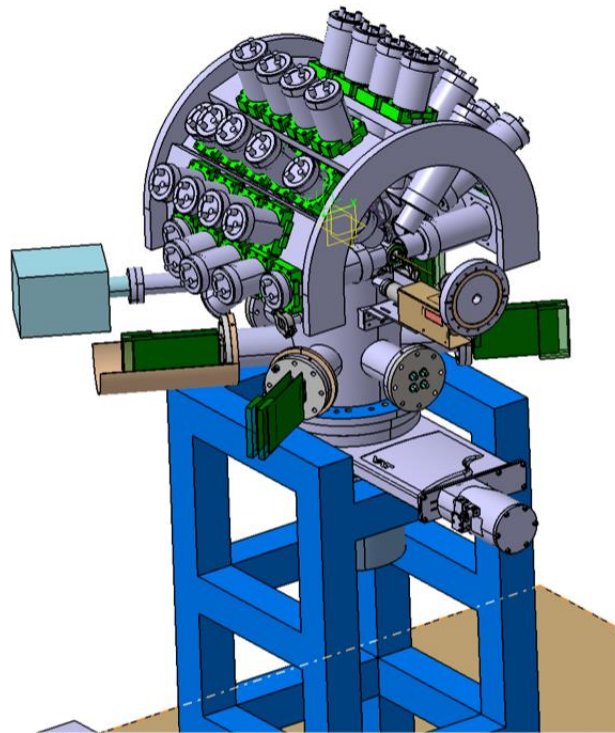

Fig. 2 : Design of the STELLA experimental station showing on top the 36 LaBr₃ detectors in a cylindrical configuration [22].

A 96 channels digital data acquisition system based on μTCA cards is developed to be used in the context of the STELLA project.

Commissioning of the new experimental set-up will start in 2016.

Acknowledgments

This work was supported by the IdEx Attractivity grant of the University of Strasbourg and by the University of Strasbourg Institute for Advanced Studies (USIAS).

References

- [1] Horiuchi H and Ikeda K 1968 *Prog. Theor. Phys. (Jpn.)* **40** 277
- [2] Jenkins D G and Courtin S 2015 *J. Phys. G: Nucl. Part. Phys.* **42** 034010
- [3] Suzuki Y and Hecht K T 1982 *Nucl. Phys. A* **388** 102
- [4] Jenkins D G *et al* 2007 *Phys. Rev. C* **76** 044310
- [5] Lebhertz D *et al* 2012 *Phys. Rev. C* **85** 034333
- [6] Goasduff A *et al* 2014 *Phys. Rev. C* **89** 014305
- [7] Sandorfi A M *Treatise on Heavy-Ion Science*, Vol.2, p.52, Ed. Allan Bromley, Plenum Press, New-York 1984, and references therein
- [8] Youngblood D H , Lui Y W and Clark H L 2007 *Phys. Rev. C* **76** 027304
- [9] Endt P M 1998 *Nucl. Phys. A* **633**
- [10] Rolfs C E and W. S. Rodney, *Cauldrons in the Cosmos*, The Univ. of Chicago Press, 1988
- [11] Patterson L J *et al* 1969 *The Astrophys. J.* **157** 367
- [12] Mazarakis M *et al* 1973 *Phys. Rev. C* **7** 1280
- [13] High M D and Cujec B 1977 *Nucl. Phys. A* **282** 181
- [14] Barron-Palos L R *et al* 2006 *Nucl. Phys. A* **779** 218
- [15] Aguilera E F *et al* 2006 *Phys. Rev. C* **73** 064
- [16] Spillane T *et al* 2007 *Phys. Rev. Lett.* **98** 122
- [17] Zickefoose J 2010 PhD Thesis : « $^{12}\text{C} + ^{12}\text{C}$ Fusion : Measurement and Advances Toward the Gamow Energy » University of Connecticut
- [18] Jiang C L *et al* 2012 *Nucl. Instr. and Meth. in Phys. A* **682** 12 ; Jiang C L *et al* 2013 *Journ. of Phys. Conf. Series* **420** 012076
- [19] Santiago-Gonzales D *et al* 2016 *EPJ Web Conf.* **117** 09011
- [20] Jiang C L *et al* 2002 *Phys. Rev. Lett.* **89** 052701
- [21] Regan P 2012 *Appl. Rad. Iso.* **70** 1125
- [22] Heine M *et al* 2016 *Journ. of Phys. Conf. Series* in press
- [23] Eller M J *et al* 2016 *Nucl. Instr. Meth. B* **365** 367
- [24] <http://ipnwww.in2p3.fr/ANDROMEDE,384?lang=en>