



This is a repository copy of *Phase shift control based Maximum Efficiency Point Tracking in resonant wireless power system and its realization*.

White Rose Research Online URL for this paper:
<http://eprints.whiterose.ac.uk/113903/>

Version: Accepted Version

Proceedings Paper:

Zhao, R., Gladwin, D.T. orcid.org/0000-0001-7195-5435 and Stone, D.A. orcid.org/0000-0002-5770-3917 (2016) Phase shift control based Maximum Efficiency Point Tracking in resonant wireless power system and its realization. In: IECON 2016 - 42nd Annual Conference of the IEEE Industrial Electronics Society. IECON 2016 - 42nd Annual Conference of the IEEE Industrial Electronics Society, 24/10/2016 - 27/10/2016, Florence, Italy. Institute of Electrical and Electronics Engineers , pp. 4541-4546. ISBN 9781509034741

<https://doi.org/10.1109/IECON.2016.7794117>

© 2016 IEEE. Personal use of this material is permitted. Permission from IEEE must be obtained for all other uses, in any current or future media, including reprinting/republishing this material for advertising or promotional purposes, creating new collective works, for resale or redistribution to servers or lists, or reuse of any copyrighted component of this work in other works.

Reuse

Unless indicated otherwise, fulltext items are protected by copyright with all rights reserved. The copyright exception in section 29 of the Copyright, Designs and Patents Act 1988 allows the making of a single copy solely for the purpose of non-commercial research or private study within the limits of fair dealing. The publisher or other rights-holder may allow further reproduction and re-use of this version - refer to the White Rose Research Online record for this item. Where records identify the publisher as the copyright holder, users can verify any specific terms of use on the publisher's website.

Takedown

If you consider content in White Rose Research Online to be in breach of UK law, please notify us by emailing eprints@whiterose.ac.uk including the URL of the record and the reason for the withdrawal request.



eprints@whiterose.ac.uk
<https://eprints.whiterose.ac.uk/>

Phase Shift Control Based Maximum Efficiency Point Tracking in Resonant Wireless Power System and its Realization

Rui. Zhao, Daniel. T. Gladwin and David. A. Stone
Department of Electronic and Electrical Engineering
University of Sheffield
Sheffield, United Kingdom
r.zhao@sheffield.ac.uk

Abstract— A modern Wireless Power Transfer (WPT) system is commonly realized by Strongly Coupled Magnetic Resonances (SCMR), which transfer energy by using the mutual inductance between coils. The application of wireless power transfer is critically limited by its energy transfer efficiency. SCMR systems are designed to transmit at a frequency that is equal to the self-resonant frequency of its power receiver, in applications where the self-resonant frequency varies during operation the measurement of the frequency is typically not possible. In this paper, a phase shift control based Maximum Efficiency Point Tracking (MEPT) approach is proposed along with implementation methodologies to enable real-world application. A prototype wireless power system with MEPT featured is built which verifies that the new MEPT method could effectively track the optimized frequencies continuously on the fly and maximise the efficiency of the WPT.

Keywords: *maximum efficiency point tracking, phase shift control, wireless power transfer, synchronous sampling*

I. INTRODUCTION

Although wireless communication technologies have cut the communication cable; electronic devices are still restricted in use by power cables. Wireless power transfer (WPT), which could remove the device's "last cable", is in increasing demand. In addition to increased portability, for vehicular application such as all-electrical vehicles, wireless power offers improved connectivity and convenience, together with higher charging speeds and robustness, applicable to a wide range of products [1]. Over many years of development, modern WPT can be realised by using several methods such as using lasers, microwaves and coupled fields [2]. The first generation of commercial WPT utilises coupled inductance for low power wireless charging (i.e. mobile phone charging) [3], and is acknowledged of having low charging efficiencies and operating over a limited distance. Higher energy efficiency and extended distances can be realised by using Strongly Coupled Magnetic Resonance (SCMR) [4]. SCMR utilises the mutual inductance between the transmitting coil and receiving coils to transfer energies from several watts to kilowatts [5, 6]. Recent research for SCMR has shown that the SCMR based wireless power systems can achieve higher efficiency but may suffer from volatility when connected with varying loads and/or geometric changes to the positioning of the coils [2]. A

simplified schematic of typical SCMR based wireless system has shown in figure 1.

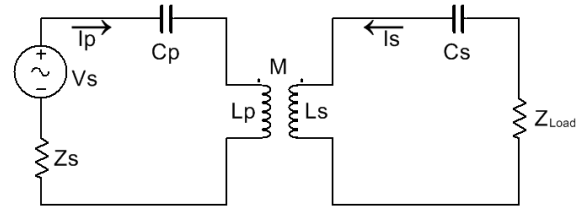

Figure 1: Simplified schematic of a SCMR based wireless power system.

In order to implement SCMR, the WPT system should be turned to a quiescent operating point. The working point of a SCMR base wireless power system strongly relies on the frequency consistency between V_s and self-resonant frequency of the LC circuit formed by C_s and L_s [7, 8]. Meanwhile, efficiency is an important consideration when deploying a wireless power system with the primary factor that affects the efficiency of a SCMR based wireless power system is the coupling coefficient and load condition [9]. The load conditions of a practical WPT system may be variable and the coupling coefficient may also be varying due to changing in relative position of the coils with each other [10]. Hence, the working point of a WPT system will be unstable and requires dynamic optimisation.

The overall performance of the WPT system relies on the transmitter driver that normally comprises of a switched power converter [11]. Modern wireless power system may work in Mega-Hz level in order to optimize the design of passive components; however, reducing the switching frequency of a converter can lower the switching losses. Although Mega-Hz SCMR systems are still widely-used, current research proposes that sub-kilo-Hz SCMR systems could also transmit kilo watts of energy with efficiency greater than 70 percent [12, 13, 14 and 15]. Therefore, reducing the working frequency could improve the overall system efficiency. Efforts to improve the system efficiency and extend the power distance of such systems also commonly focus on the adjustments of load impedance. The research carried out by [16] maintains an optimised load impedance by using an auxiliary converter whereas [17] illustrates a dynamic impedance matching approach that employs a semiconductor switch based matching circuit. Investigating other components of the system, several researches improve the system efficiency by enhancing the performance of the power converter and both coils [18, 19].

Research to date has predominantly been restricted to pure resistive loads with many proposing bulky solutions that have limited application use due to physically requirements or those that introduce significant losses. Furthermore, little has been achieved in tracking the quiescent operating point which removes the impacts on coil relative positions and changes in electrical characteristics at the receiving device.

In this paper the realization of a novel Maximum Efficiency Point Tracking (MEPT) methodology is introduced that provides a practical means to track the quiescent operating point on the fly to maximise the efficiency of the system that is independent from changes in the load and operating environment. In the following sections the operational theory for MEPT will be described along with the challenges for implementation. A novel synchronous sampling methodology it then proposed to realise the low level control requirements of the MEPT. Finally, a prototype wireless power system is built in order to evaluate and verify the methodology proposed in this paper and the results are presented.

II. THEORY OF PHASE SHIFT CONTROL BASED MEPT

As can be seen form figure 1, for a given L_s and C_s , system efficiency may achieve its maximum point when F_o (converter output frequency) is equal to the self-resonant frequency of the LC resonator which is comprised of L_s and C_s [7, 8].

$$F_o = F_{L_s C_s} \quad (1)$$

However, measuring the real-time $F_{L_s C_s}$ is relatively difficult since the receiving coil L_s also acts as the voltage source of the LC resonator. Without calculating the real-time resonant frequency, the balance between F_o and the real time self-resonant frequency $F_{L_s C_s}$ can be observed by comparing the phase difference between the current of first resonator and the output voltage of the second resonator. Figure 2 shows the relationship between the system efficiency (this includes the power converter and the wireless power transmission) and the phase shift angle of transmitting current (I_T) and receiving voltage (V_R). As may be seen from the figure the system efficiency is proportional to the phase difference between I_T and V_R .

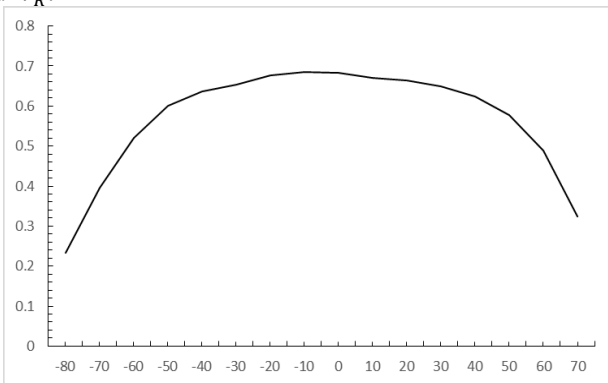

Figure 2: System efficiency against phase shift angle of transmitting current and the receiving voltage.

The phase difference between the transmitting current and receiving voltage is the key parameter to realise the phase shift control based MEPT. Assumed that the transmitting current and receiving voltage are sampled by using two centrally clocked data converters, the simplified approach to calculate the required phase difference can be realised by comparing the zero-crossing points of those two signals. However, for the wireless application discussed in this paper, the two data converters are located independently in the transmitter and receiver accordingly, hence the data converters cannot be clocked from a common source and synchronous sampling is not possible. In the following sections, the practical implementation of this MEPT approach will be introduced together with a methodology to realise the synchronise sampling of I_T and V_R .

III. SYSTEM TOPOLOGY

The detailed control signal topology is shown in figure 3. On the transmitter side, the transmitting current signal will be first coupled into a current transducer. The output of the current transducer will then amplified and shifted into a required level in order to be sampled by the data converter. As shown in figure 3, two signals are required for the data converter. The sample timing signal provides the timing base for the data converter and the latch signal for the First In, First Out (FIFO) memory. The sampled digital data is then stored in the Tx FIFO and can be accessed by the microcontroller (MCU). Meanwhile, the receiving voltage signal is received by an ISM RF transceiver. Using the signals from the Tx FIFO and the voltage signal from the RF transceiver, the MCU can then calculate the phase difference.

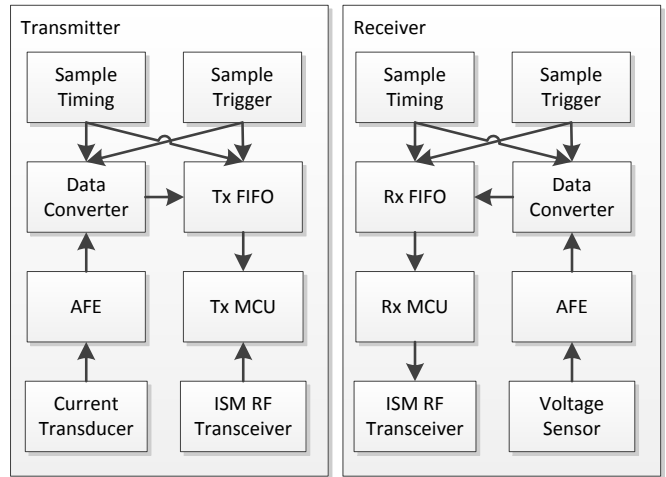

Figure 3: Topology of the control signals in a typical phase shift control based MEPT system.

On the receiver side, the receiving voltage signal can be measured by a voltage divider. After passing through an Analog Front End (AFE), the signal will be sampled by a data converter which has the same architecture of the data converter on the transmitter side. The corresponded digital values will be

stored in a FIFO memory and an on-board MCU will process the data out and send it to the transmitter via an ISM transceiver.

As can be seen from figure 3, the challenge in realising the phase shift control based MEPT is being able to sample the transmitting current and receiving voltage simultaneously given two synchronized sample trigger signals. Different to a conventional acquisition system where the sample trigger signal is provided by the system controller, in this design, the sample trigger signal is provided by an auxiliary circuit. Hence, it is necessary to synchronise these auxiliary circuits so that in turn synchronized sampling is possible.

IV. SAMPLE TRIGGER SIGNAL GENERATION

In this section two methodologies are proposed to generate the required sample trigger signals for the auxiliary circuits.

Clock based trigger signal generator

The first method enables the auxiliary circuits to operate independently without any direct communication between the two. The solution is to use an external common clock source or on-board precision clock sources. Figure 4 shows the topology of the targeted trigger signal generator.

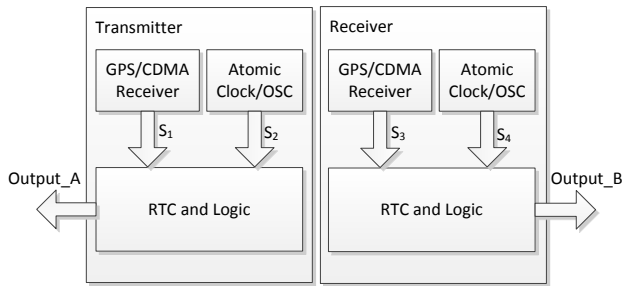

Figure 4: Topology of the clock based trigger signal generator

The signal generator shown above can be considered as a precision alarm. The two outputs will be synchronized since the Real Time Clocks (RTCs) installed both in the transmitter and receiver are clocked by satellite synchronization signals or on-board precision oscillators.

If the satellite synchronization signal is used, the logic section (can be a controller or programmable logic) gets the UTC output from the GPS receiver, and gives a periodic trigger output based on the timer setting (i.e. every 300mS). Since the difference between the outputs of GPS receivers are negligible, those two trigger outputs can also be considered as synchronized. The advantage of using a satellite synchronization signal is that it is highly robust and requires no calibration. The trigger signals can also be considered as precisely synchronized since the trigger timing is a relay on the clock of the satellite which is obtained from a Rubidium or Hydrogen atomic clock.

For those applications where the satellite signals are not available, on-board atomic clocks or precision oscillators can be used. During manufacture, the on-board RTC will be calibrated to the UTC (or any given time), after calibration the system will be clocked by its on-board clock source and provides the trigger output periodically. For example atomic clock sources are accurate at the level of parts in 10^{-12} (i.e. SA.33 atomic clock manufactured by microsemiTM) however, the system may require periodical calibrations within its lifespan. This method is considered expensive due to the cost of the source components required and is suited to high-end applications where high speed direct communication between the receiving and transmitter is not possible or desirable.

Laser based trigger signal generator

The second method relies on communication between the transmitter and the receiver at a very high rate allowing a single trigger source to be used thus eliminating the high cost of clock sources in the previous method. As can be seen in figure 5, a base trigger signal will be generated on the transmitter to drive several laser diodes. The laser beam generated will travel to the laser detector on the receiver board where the circuit will then produce a trigger signal for sampling. To ensure synchronous sampling, the transmitter also has a laser detector to pick up the laser beam after passing through an attenuated waveguide to ensure delays seen by the receiving sampling circuit are the same as the transmitter sampling circuit.

$$T_2 + T_3 \approx T_4 + T_5 \quad (2)$$

This laser based approach has two issues restricting its implementation in real-world applications. Firstly, the position of the transmitter's laser diodes must be directed at the receivers' laser detector. Secondly, the laser signal may be interfered by external light sources which may limit the environmental conditions that the WPT can operate in.

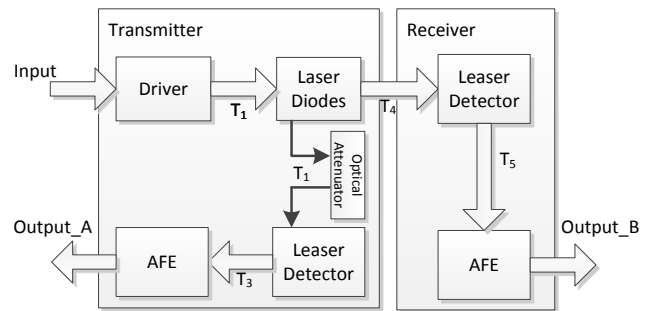

Figure 5: Topology of the laser based trigger signal generator

V. PROTOTYPE DESIGN

A prototype WPT has been designed based on the approach illustrated above using the topology has shown in figure 6. The

prototype can deliver 300W to the receiver wirelessly.

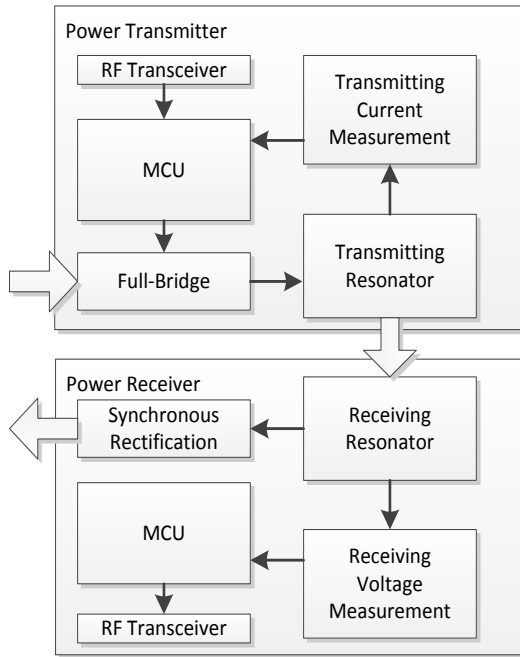

Figure 6: Topology of the prototype WPT system employing phase shift based MEPT.

The prototype is shown in figure 7. The transmitter is designed to utilise 12-24V DC power (from one or two 12V lead acid batteries) and provides AC output with frequencies between 500 kHz to 1.5MHz. The MOSFETs used in the prototype converter are IPT020N10N3 and the transmitting current is measured by a 20m ohm shunt resistor. The system is controlled by STM32F334 and stm32F030 microcontrollers.



Figure 7: Prototype WPT system employing phase shift based MEPT.

VI. TEST AND EVALUATION

The converter of the prototype was designed to provide a switched voltage output with frequencies ranged from 500 kHz to 1.5MHz. Figure 8 shows the output voltage and current waveform of the drive converter. As can be seen from figure 8 and 9, the converter can provide the required high frequency

voltage output (blue waveform) which is connected to the transmitting resonator and generates the required sinusoidal current (red waveform) within the desired frequency region.

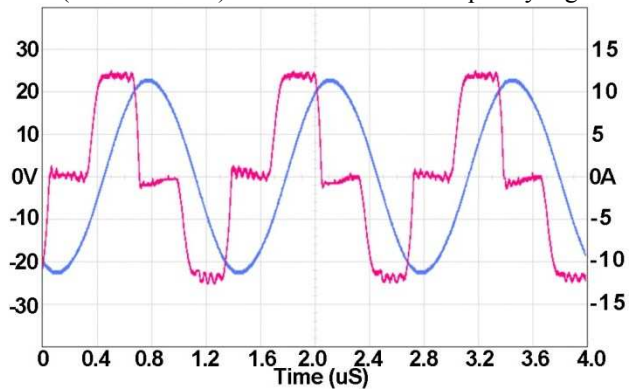

Figure 8: Output voltage (Blue) and current (Red) waveform from the converter.

In order to evaluate the MEPT approach introduced in this paper, the transmitting current is externally measured by a current probe and the receiving voltage is measured by a differential probe. Those measurements are fed into an oscilloscope where the phase difference can be visualized. The following figure shows the waveform from the oscilloscope at maximum efficiency point.

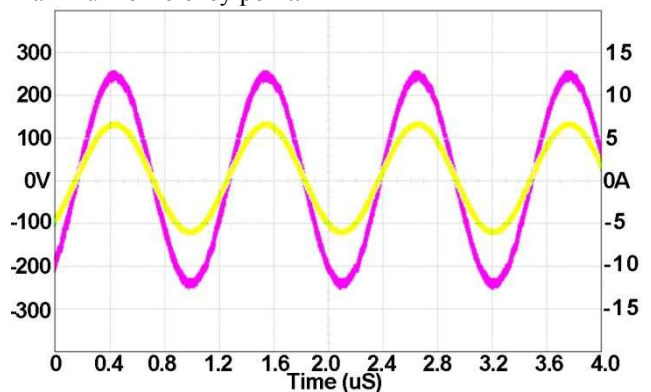

Figure 9: Oscilloscope capture shows the transmitting current (Yellow) and receiving voltage (Magenta) at maximum efficiency point.

In order to simulate the changes on self-resonant frequency of the receiver, additional capacitances are applied to the load. The additional capacitance forces the self-resonant frequency lower than the original self-resonant frequency, which will affect the efficiency of the wireless power system. The results are presented in figure 10 showing the comparison of the efficiencies of the WPT with (Blue), and without (orange) MEPT control. As may be seen from figure 10, without MEPT control, the system efficiency diverged from the optimised efficiency level where the MEPT system could change the output frequency and maintain its efficiency level.

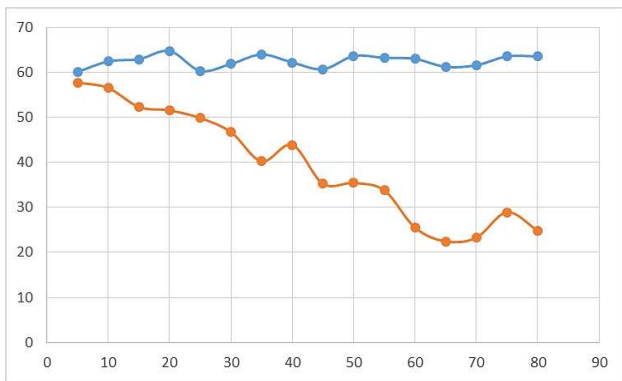

Figure 10: Comparison between the power system with (Green) and without (Orange) MEPT.

VII. CONCLUSION

This paper introduced a novel maximum efficiency point tracking methodology and its realization. The approach to maximise the efficiency by dynamically matching the converter's output frequency with the receiver's self-resonant frequency is demonstrated to be effective. However, to provide the synchronous sampling required a method to trigger two physically separated data converters simultaneously is required. Two methods are proposed in the paper, the first assumes no direct communication between the data converters and instead relies on a synchronised time source. The second method uses a laser to establish a high speed communication link so that a common trigger source can be used. The first method is appropriate where no direct communication is possible but utilises expensive components therefore limited to high end applications. The second method relies on having a line of sight between the receiver and transmitter but is much lower in cost. A prototype wireless power system has been built for evaluation of the MEPT methodology and results presented showing that the efficiency of the WPT system can be maintained under a varying load conditions. By implementing the MEPT methodology presented in this paper the wireless power system can be used for WPT in systems where the load is variable, the relative coil positions alter and environmental conditions fluctuate.

REFERENCE

- [1] K. Siddabattula, "Why not a wire: The case for wireless power," TESLA Wireless Power Solutions, Online. Accessed at <http://www.wirelesspowerconsortium.com/data/downloadables/1/2/1/1/why-not-a-wire-the-case-for-wireless-power.pdf>, Last accessed, Jan 2015.
- [2] A. P. Sample, et al., "Enabling seamless wireless power delivery in dynamic environments," Proceedings of the IEEE 101.6, pp.1343-1358, 2013.
- [3] M. Pinuela, et al., "Maximizing DC-to-Load Efficiency for Inductive Power Transfer," Power Electronics, IEEE Transactions on, vol. 28, pp. 2437-2447, 2013-01-01 2013.
- [4] P. Si, et al., "A frequency control method for regulating wireless power to implantable devices," Biomedical Circuits and Systems, IEEE Transactions on 2.1, pp. 22-29, 2008.
- [5] G. A. Covic and J. T. Boys, "Inductive power transfer," Proc. IEEE, vol. 101, pp. 1276-1289, Jul. 2013.
- [6] S. M. Weinberger, "Preliminary design development of 100 kW rotary power transfer device," NASA, Technical Report, 1982.
- [7] A. Kurs, et al., "Wireless power transfer via strongly coupled magnetic resonances," Science, vol. 317, no. 5834, pp. 83-86, Jul. 2007.
- [8] C. Chen, et al., "A study of loosely coupled coils for wireless power transfer," IEEE Trans. Circuits Syst.-II, Exp. Briefs, vol. 57, no. 7, pp. 536-540, Jul. 2010.
- [9] J. Sibue, et al., "A global study of a contactless energy transfer system: analytical design, virtual prototyping and experimental validation," IEEE Trans. Power Electron, vol. 28, pp. 4690-4699, Oct. 2013.
- [10] H. Li, et al., "A maximum efficiency point tracking control scheme for wireless power transfer systems using magnetic resonant coupling," IEEE Trans. Power Electron., vol. 30, no. 7, pp. 3998-4008, Jul. 2015.
- [11] K. D. Papastergiou and D. E. Macpherson, "An airborne radar power supply with contactless transfer of energy – Part II: converter design," IEEE Trans. Ind. Electron, vol. 54, pp. 2885-2893, May. 2007.
- [12] C.S. Wang, et al., "Investigating an LCL load resonant inverter for inductive power transfer applications," IEEE Trans. Power Electron, vol. 19, no. 4, pp. 995-1002, July 2004.
- [13] R. Liu, et al., "Comparison of capacitively and inductively coupled parallel resonant converters," IEEE Trans. Power Electron., vol. 8, no. 4, pp. 445-454, Oct. 1993.
- [14] N. Nguyen-Quang, et al., "Pulse density modulation strategies for high-frequency three-phase to single-phase matrix converter," EPE-2009, Barcelona, Spain, 2009.
- [15] M. Venturini: "A New Sine Wave In, Sine Wave Out Conversion Technique Eliminates Reactive Elements", in Proc. 7th National Solid-State Power Conversion Conf. POWERCON 7, pp. E3-1-E3-15, Mar. 1980.
- [16] H. Ishihara, et al., "A voltage ratio-based efficiency control method for 3 kW wireless power transmission," 2014 Twenty-Ninth Annu. IEEE Appl. Power Electron. Conf. and Expo., pp. 1312-1316, Mar. 2014.
- [17] B. H. Waters, et al., "Powering a ventricular assist device (VAD) with the free-range resonant electrical energy delivery (FREE-D) system," Proc. IEEE, vol. 100, no. 1, pp. 138-149, Jan. 2012.

- [18] C. Zhao, et al., "Active resonance wireless power transfer system using phase shift control strategy," Applied Power Electronics Conference and Exposition (APEC), 2014 Twenty-Ninth Annual IEEE, 2014.
- [19] S. H. Lee and R. D. Lorenz, "Development and validation of model for 95% efficiency 220W wireless power transfer over a 30cm air-gap," IEEE Trans. Ind. Appl., vol. 47, no. 6, pp. 2495–2504, Nov. 2011.