

Towards Semantically Integrated Models and Tools for Cyber-Physical Systems Design

Peter Gorm Larsen¹, John Fitzgerald², Jim Woodcock³, René Nilsson¹, Carl Gamble², and Simon Foster³

¹ Department of Engineering, Aarhus University, Denmark, {pgl, rn}@eng.au.dk

² School of Computing Science, Newcastle University, UK

{john.fitzgerald, carl.gamble}@ncl.ac.uk

³ Department of Computer Science, University of York,

{jim.woodcock, simon.foster}@york.ac.uk

Abstract. We describe an approach to the model-based engineering of embedded and cyber-physical systems, based on the semantic integration of diverse discipline-specific notations and tools. Using the example of a small unmanned aerial vehicle, we explain the need for multiple notations and collaborative modelling. Learning from experience with binary co-modelling based on a bespoke operational semantics, we describe current work delivering an extended approach that enables integration of multiple models and tools in a consistent tool chain, founded on an extensible semantic framework exploiting the Unifying Theories of Programming.

1 Introduction

In Cyber-Physical Systems (CPSs), computing processes interact closely with physical systems and humans. Examples range from networked embedded systems to large-scale applications such as distributed transport systems. The effective design of dependable CPSs requires methods and tools that bring together diverse engineering disciplines. Without these it would be difficult to gain confidence in the system-level consequences of design decisions made in any one domain, and it would be challenging to manage trade-offs between them. How, then, can we support such multidisciplinary design with semantically well-founded approaches?

We start from the view that disciplines such as software, mechatronic and control engineering have evolved notations and theories that are tailored to their needs, and that it is undesirable to suppress this diversity by enforcing uniform general-purpose models. Our goal is to achieve a practical integration of diverse formalisms at the semantic level, and to realise the benefits in integrated tool chains. To the CPS engineer, the system of interest includes both computational and physical elements, so the foundations, methods and tools of CPS engineering should incorporate both the discrete-event (DE) models of computational

processes, and the continuous-value and continuous-time (CT) formalisms of physical engineering.

Our initial approach is to support the development of collaborative models (*co-models*) containing DE and CT elements expressed in diverse notations, and to support their analysis by means of co-simulation based on a reconciled operational semantics of the individual notations' simulators. This enables exploration of the design space and allows relatively straightforward adoption in businesses that are unfamiliar with formal methods. Our current work extends this approach with co-simulation of extensible groups of semantically diverse models, and at the same time the semantic foundations are extended using Unifying Theories of Programming (UTP) to permit analysis using advanced tools.

We are not unique in proposing co-models as a solution to the problem of modelling multi-domain systems, the HybridSim [29] tool chain, supports importing existing system components from multi-domains into SysML blocks [27], where Functional Mock-up Units (FMUs) and configuration scripts can be generated and co-simulated. CPSs are also modelled as hybrid systems, including techniques such as hybrid statecharts [20] and hybrid automata [1], where finite control graphs describe discrete behaviours and differential equations describe continuous behaviours. More recently, several languages have been proposed to describe hybrid systems and to support simulation and verification and a survey of these is presented by Carloni et al. [6].

The challenge of providing semantic foundations for CPSs that allow the development of comprehensive and integrated formal models is widely acknowledged [4,23]. The need for rigorous modelling foundations to ensure safe CPSs and the importance of well-founded semantic meta-models for CPSs with the ability to model and compare heterogeneous computational models have been identified [7], and the Ptolemy framework, with its actor-based model, proposed as a solution. Our UTP approach similarly provides a uniform notation for computational models in the hybrid relational calculus, with *CyPhyCircus* providing actor-style concurrency. Other semantic approaches to CPS modelling include MontiArc, which is given a denotational semantics in [16] and a semantic agent framework for CPS.

We first introduce a small case study based on the control of a quadrotor Unmanned Aerial Vehicle (UAV) in Section 2, demonstrating the merits of specialist notations for DE and CT modelling of system elements. Using this as a running example, we show how a single DE model in the notation VDM-RT and a CT model in the 20-sim tool can be successfully integrated in a co-model (Section 3). We then describe our current work extending this approach to accommodate more diverse component models, and to better integrate co-modelling in the full development toolchain (Section 4). We discuss our approach to pro-

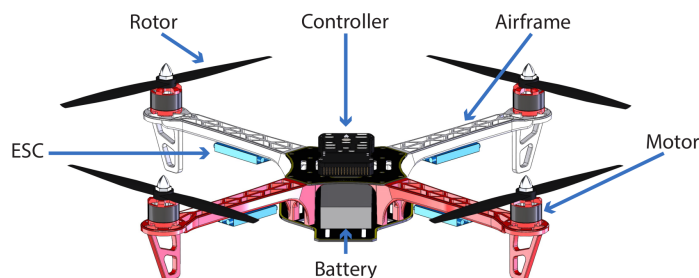

Fig. 1. Main components of a quadrotor UAV

viding integrated semantic foundations needed to underpin such co-modelling (Section 5) before reviewing related work and looking forward (Section 6).

2 Example: UAV Control

We consider the model of a small quadrotor UAV, which involves software, electrical and mechanical domains [15]. The controller is implemented on an embedded device with discrete logic, while the electronics and physical dynamics are described in terms of differential equations over continuous values. We would thus expect to have a CT model of the physical dynamics and a DE model of the control application. We use VDM-RT as the DE notation and 20-sim as the CT notation; both are described in [9]. VDM-RT is an extension of the Vienna Development Method's modelling language with features for object-orientation, concurrency and real-time computation, including the distribution of processes to virtual CPUs [28]. 20-sim is a package for modelling and simulating complex physical systems [21,2], which provides an abstract representation of differential equations. Iconic diagrams with flow ports, adopted from bond graphs, are used to describe both the electronics and mechanics of the propulsion system, whereas rigid body dynamics are modelled directly with differential equations.

Our UAV (Figure 1) consists of an airframe, sensors, actuators, controller and battery. Sensors include accelerometers, gyroscopes and GPS. The actuators are four Electronic Speed Controllers (ESCs), motors and rotors. The overall system controller reads sensor data and steers the UAV to a desired state by adjusting the set points of each motor. The desired state is usually given by a pilot and retrieved through telemetry.

2.1 Modelling the Physical Components

The CT model of the UAV, Figure 2, shows the main components of the model along with their relationships. From the diagram we can trace a loop formed by

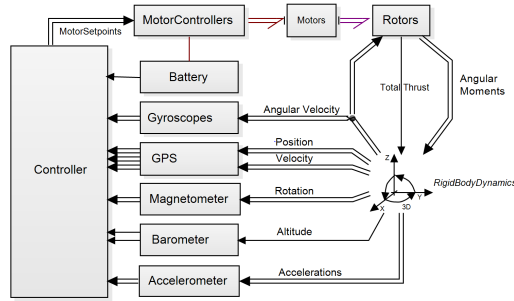

Fig. 2. Top level of the CT model showing connections of the main model elements

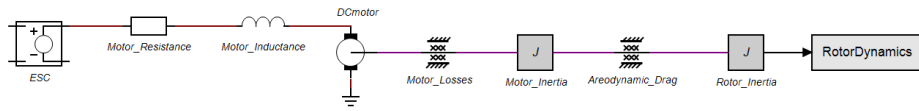

Fig. 3. Part of the CT model of quadrotor UAV propulsion system

the controller \rightarrow motor controllers \rightarrow motors \rightarrow rotors \rightarrow rigid body dynamics \rightarrow sensors \rightarrow controller. The controller itself is modelled in the DE environment, so the purpose of the controller block here is to contain the declarations defining the variables we expect the DE controller to set and also those monitored variables we want to expose to the DE controller.

Following the loop round from the controller first we arrive at the motor controllers and Figure 3 depicts expanded 20-sim models of the ESC, motor and rotor using iconic diagrams. The ESC is represented by a controlled voltage source and the motor is modelled as an ideal DC motor with electrical parasitic components, mechanical losses and inertia. This construction allows the modeller to specify relatively simple equations for each subcomponent, such as Ohm's law for a resistor: $U = R * I$. By assigning indifferent causality to all flow ports, an explicit model is achieved, enabling the 20-sim tool to calculate the resulting differential equations.

In cases where the dynamics are not easily described by composition of simple components such as in the rigid body model of the UAV, differential equations are recorded directly. For example, angular acceleration is calculated with a differential equation, since it incorporates gyroscopic effects (Equations 1 and 2):

$$\mathbf{a}_{ang} = \mathbf{I}^{-1} * (-\mathbf{v}_{ang} \times (\mathbf{I} * \mathbf{v}_{ang})) + \mathbf{t} \quad (1)$$

$$\mathbf{v}_{ang} = \int \mathbf{a}_{ang} \quad (2)$$

```

parameters
// Magnetic Sensitivity, default for the HMC5883L Digital Compass (gauss/LSB)
real magSens = 1090;
// Earths magnetic field at Aarhus, DK: {North + | South - , East + | West - , Down + | Up -}
// From http://www.ngdc.noaa.gov/geomag-web/#igrfwmm
real earthMagField [3] = [16900.1; 740.9; 47304.5] (nT);
variables
real quadMagField [3];
equations
// Effect of the magnetic field converted to the body frame
quadMagField = Rotation*earthMagField;
// Scaling and sensitivity
MagnetometerOut = quadMagField/100000*magSens;

```

Fig. 4. Magnetometer component of the CT model

where \mathbf{a}_{ang} and \mathbf{v}_{ang} are angular accelerations and velocities respectively (three-dimensional); \mathbf{t} is the angular moments and \mathbf{I} is the rotational inertia matrix. These equations are easily represented in 20-sim's textual notation as follows:

$$\mathbf{a} = \text{inverse}(\mathbf{I}) * (-\text{cross}(\mathbf{v}, (\mathbf{I} * \mathbf{v})) + \mathbf{t});$$

$$\mathbf{v} = \text{int}(\mathbf{a});$$

The output from the rigid body dynamics is processed by five blocks, each representing one of the sensor components possessed by the UAV. The function of these blocks is to take the raw dynamic properties of the UAV body, such as linear and rotational acceleration, velocities and positions and to process them to give sensors outputs that are consistent with those of the real hardware sensors on the UAV. The sensor models here, such as the magnetometer shown in Figure 4, are ideal in the sense that their outputs do not contain error or exhibit fault behaviour as described in [9].

Iconic diagrams let the engineer build a model by connecting blocks that represent dominant physical elements; blocks contain equations representing how those elements affect the effort and flow. This is “what we want to model”. The above equations are not, however, suitable for simulation and 20-sim manipulates them, according to the connections between their flow ports, into a form that can be simulated using one of the integration methods offered by the tool. Importantly, all elements connected by power bonds are considered when generating the new set of equations and so interactions and feedback between components that may be on opposite corners of the model are included; so we arrive at a set of equations that represent the “dynamic behaviour of what we want to model”.

If the engineer were to attempt to model this system using a DE environment such as VDM-RT then they are obliged to do two things. First, instead of being able to think about the behaviour of individual elements, they must generate the equations that represent the dynamic behaviour of the whole system, including feedback, manually. This dynamic system would change each time a component

is introduced or removed from the system they are modelling. Second, the engineer is obliged to construct numerical solvers that implement one or more of the integration methods required to generate continuous results. Thus, while it is not impossible to model such a dynamic system using a DE environment it is much more practical to do so using a CT tool. The iconic diagrams help manage the complexity of generating suitable dynamic models by allowing the engineer to only have to think about the dominant elements and their connections.

2.2 Modelling the Controller

The control application on a quadrotor UAV has two major objectives: first it must keep the UAV stable in the air and second it must react to pilot input. Figure 5 shows a block diagram of the control application model. Here the control loop from figure 2 is completed with the DE blocks sensor data processing → control architecture → motor control. Sensor fusion and filtering are performed on the input data from the sensors to obtain accurate estimates of angular and translational acceleration, velocity and position. These estimates are used in the control architecture along with processed pilot inputs to calculate control signals for the motor control block. These control signals are expressions of angular accelerations and total thrust, which decouples the control architecture from the motor/rotor configuration. A UAV can have from 3 to 16 rotors and, with proper transformations in the motor control block, the control architecture can be reused for any number of rotors.

The control architecture block is shown inside a small class diagram, including flight modes and position and attitude controllers. The flight modes are used with a strategy design pattern, such that the pilot is able to change flight mode in-flight. Each of the flight mode implementations may use both the position and an attitude controller. The position controller is based on Proportional Integral Derivative (PID) control, whereas two alternative attitude controllers are

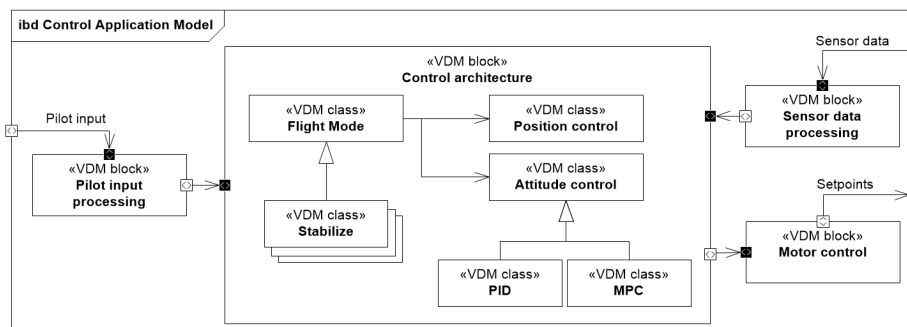

Fig. 5. High level block diagram of the control application model

modelled (and subsequently implemented): a PID-based and a Model Predictive Control (MPC) [5] based controller. With the use of inheritance the two controllers are made interchangeable, enabling comparison through co-simulations by comparing the overall system performance.

Figure 6 shows a code snippet, from the position controller, with a type declaration and an operation, which calculates the bearing between two vector positions. This illustrates the use of type invariants and operation pre-conditions in VDM. A type invariant is a condition that must be true for all instances of that particular type throughout the entire model execution, whereas a pre-condition needs only to be true when the given operation is called. Similarly post-conditions can be added to operations to further improve the documentation of the precise properties of the model. If either an invariant or a pre- or post-condition is violated a runtime error is thrown, enabling the developer to correct the faulty behaviour of the model.

```
values
  MAX_BEARING_CD = 36000;

types
  public Bearing = real
  inv b == b >= 0 and b < MAX_BEARING_CD;

operations
  public getBearingCd: Vector`Vector3 * Vector`Vector3 ==> Bearing
  getBearingCd(origin,destination) ==
    let bearing = Vector`atan2(destination.y - origin.y, destination.x - origin.x) in
    return AP_Math`wrap(AP_Math`radToCentiDegrees(bearing), 0, MAX_BEARING_CD)
  pre origin <> destination;
```

Fig. 6. Pre condition and type invariant in VDM-RT

One of the advantages of using VDM-RT with the Overture tool compared to other formal modelling tools is the support for calling external Java and native C++ libraries. This is exploited in the modelling of the MPC controller, where an external C++ optimisation library is used. This library is also used in the realisation code, which is deployed to the real UAV. An increase in model fidelity is thereby achieved. VDM-RT's built-in notion of time makes it easy to create a soft real-time scheduling mechanism. In the control application model the main control loop and sensor readings are scheduled. Sensor readings are scheduled based on the availability of data from the different types of sensor. Figure 7 shows the controller model being deployed onto a user defined CPU, this allows the execution time of each instruction to be simulated. The main control loop is run at 400 Hz for the PID-based attitude control, while the MPC controller could only be run at 100 Hz in the realisation, as it requires far more computation.

```

instance variables
public static arduCopter: ArduCopter := new ArduCopter();
cpu : CPU := new CPU(<FP>, 168E6); -- PixHawk: 168MHz Cortex M4F CPU

operations
public ArduPilot: () ==> ArduPilot
ArduPilot() ==
cpu.deploy(arduCopter, "ArduCopter");

```

Fig. 7. Defining CPU and deploying a controller model in VDM-RT

The DE model architecture is presented here using SysML⁴, reflecting the object-oriented class structure of the VDM-RT model. This structure also lends itself to the generation of product source code. Apart from the structure, there are several reasons why constructing the controller in DE is preferable to a CT model. 20-sim does support the definition of *code* blocks with models, there are no language differences between these block and the normal *equation* blocks, the only different being that the statements are not reordered to improve simulation speed, and so the order of equation execution and branching statement evaluation is explicit. This permits the definition of “simple” controllers, but there are limitations that make more complex controllers challenging.

The argument for a DE model of a controller mirrors that for using a CT formalism to model the physics. The UAV operating modes are described in VDM-RT using a *modal controller pattern* [14], and standard inheritance allows the alternate PID and MPC motor controller implementations to be easily described. Both are much more complex in 20-sim, which lacks explicit support for these features. Similarly, VDM-RT’s support for rich data structures such as mappings, sets and sequences allows the description of more sophisticated control than the CT formalism of 20-sim with its basic boolean, numeric and matrix data types. The CT formalism lacks a method or function call concept, requiring calculations at the call point, increasing the cognitive workload in understanding and maintaining the controller. Finally, the explicit time budget for each instruction in the DE model allows us to offer evidence regarding the real-time performance of the controller.

3 Binary Co-modelling and Co-Simulation: the Crescendo Tool

In this section we describe co-modelling and co-simulation in which DE models are developed in VDM-RT supported by the Overture/VDM simulator [22] and CT models are developed in the 20-sim tool [21].

⁴ Figure 5 is not a well-formed SysML block diagram: we have condensed the presentation for reasons of space.

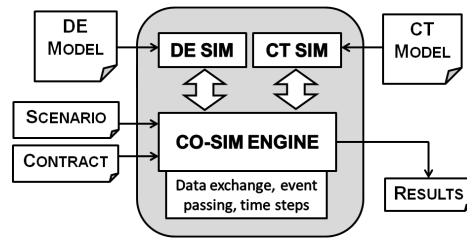

Fig. 8. Tool-oriented perspective of a co-model.

3.1 Crescendo Framework

The DESTTECS project⁵ developed methods and tools for co-modelling and co-simulation, based on co-models consisting DE models in VDM-RT and CT models in 20-sim [3]. These were embodied in the Crescendo tool⁶ based on a master-slave architecture with the Overture and 20-sim simulators acting as slaves. Co-simulation was defined by a reconciled operational semantics [8]. The technology and industry experience are described in [9].

In a Crescendo co-model the interface between DE and CT models (here called a *contract*) identifies the shared features of the two constituent models. These are: *design parameters* that are kept constant in one simulation; *events* which are typically zero crossings⁷; and *variables* that are passed between models as they run in their respective simulators during a co-simulation.

The Crescendo tool is structured as in Figure 8, where the master co-simulation engine coordinates the DE simulator (realised in the Overture/VDM tool [22]) and the CT simulator (realised by the 20-sim solvers). Based on the contract, the co-simulation engine exchanges data between the simulators and produce logs of results. In order to explore potential fault scenarios it is possible also to include scripts that can activate latent errors in the constituent models.

3.2 UAV Co-Model

The UAV co-model is connected via a contract that in reality would fall inside the embedded controller. On the CT side we find the elements of the physical world including the motors, framework, battery and sensors, and on the DE side we find the model of the controller. The monitored variables in this case are

⁵ <http://www.destecs.org>

⁶ <http://www.crescendotool.org>

⁷ A zero-crossing is a point where the sign of a mathematical function changes (e.g. from positive to negative), represented by a crossing of the axis (zero value) in the graph of the function. It is a commonly used term in electronics, mathematics, sound, and image processing.

the outputs of the sensor devices (gyroscopes, accelerometers and GPS) and the controlled variables are the set points for each motor. The contract and models abstract the details of how physical sensors compute their values and also how the ESC senses motor motion and controls the power it feeds to them.

Model-based design will be ineffective if model and realisation behaviour do not align; effort is therefore directed into achieving a known level of model fidelity. For example, by comparing co-simulations and real-time test, an average deviation of 2 degrees has been achieved for the attitude angles; in practice dynamic response is at least as important as such static measures. Crescendo's scripting feature allows emulation of predefined user input. Figure 9 shows both the co-simulated and measured (test) response of the UAV to scripted reference angle changes.

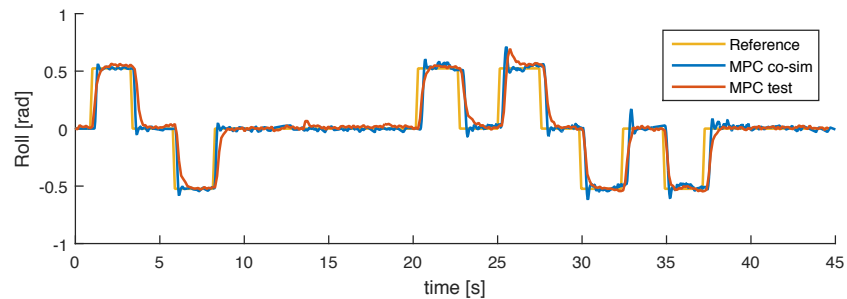

Fig. 9. Graph comparing of the modelled and actual roll response of the UAV to a reference input.

3.3 Evaluation of Crescendo

Crescendo has been successfully used to model embedded systems ranging from line following robots through to dredging excavators, and demonstrable gains in development effort have been seen through a reduction in the number of physical prototypes needed to converge to a final design [9]. However, this co-simulation technology is deficient in two significant areas. First, it only supports bipartite co-models using a single DE model in VDM-RT and a single CT model in 20-sim. The semantic foundations are limited to an operational semantics developed for these two formalisms, and so there is significant effort in modelling larger and more complex CPSs that may have a greater variety of constituent models. Second, it stands alone in a development process and assumes the engineer both understands what they wish to model before starting, and has external

means to analyse the results of simulation. These concerns formed the basis for developing an integrated tool chain in the ongoing INTO-CPS project⁸.

4 N-ary Multi-modelling: the INTO-CPS Tool Chain

In order to address the limitations of the binary co-modelling approach based on bespoke operational semantics, as embodied in Crescendo, we are developing a more open *integrated tool chain* to allow n-ary co-simulation of a wider range of model types. In order to facilitate this, we develop an extensible semantic foundation using UTP. Figure 10 gives a graphic overview of the toolchain, which is being developed in INTO-CPS.

In the INTO-CPS tool chain, requirements and CPS architectures may be expressed using SysML. We define an architectural profile that allows cyber and physical system elements to be identified such that each of these elements corresponds to a constituent model. From each element, we generate an interface following the Functional Mockup Interface (FMI) standard⁹. In our approach, which is inspired by HybridSim, the tools in which the constituent models are developed can then import these interfaces and export conformant executable *Functional Mockup Units (FMUs)*.

Heterogeneous system models can be built around the FMI interfaces, permitting these heterogeneous *multi-models* to be co-simulated, and to allow static analysis, including model checking (of appropriate abstractions). A Co-simulation Orchestration Engine (COE) manages the co-simulation of multi-models and is built by combining existing co-simulation solutions. The COE permits hardware-in-the-loop and software-in-the-loop analysis. Results of multiple co-simulations can be collated, permitting systematic design space exploration, and allowing test automation based on test cases generated from the SysML requirement diagrams [25].

To date, the CPS SysML profile has been demonstrated in Modelio¹⁰. FMI-conformant constituent models have been produced from VDM-RT, and the CT formalisms 20-sim and OpenModelica [13]¹¹.

Returning to the UAV case study, the INTO-CPS tool chain will support multiple improvements over the Crescendo version of the model. The first of these is the support for more than two FMUs in a single co-model. This greatly reduces the workload when constructing a model of a swarm of identical UAVs as it is possible to create multiple instances of the UAV controller and physics

⁸ <http://http://into-cps.au.dk/>

⁹ FMI essentially defines a standardised interface to be used in computer simulations to develop complex CPSs.

¹⁰ <http://www.modelio.org/>

¹¹ <https://www.openmodelica.org/>

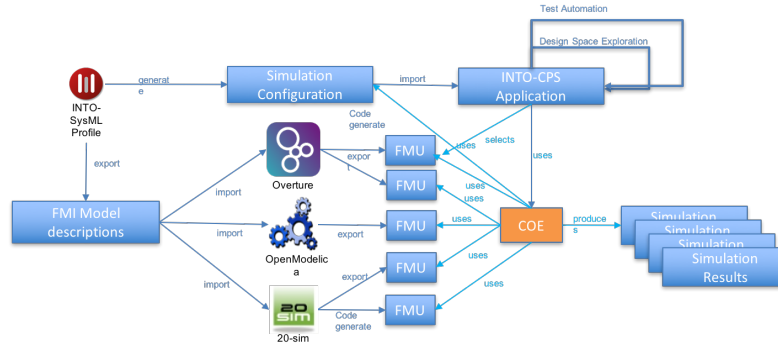

Fig. 10. The current INTO-CPS Tool Chain

models. The resulting swarm of UAVs then interact via one or more FMUs representing communications and the physical world. The second benefit is that FMUs can be created using any tool that exports a compatible FMU and so could allow the generation of a terrain model from a mapping tool. The final benefit is the possibility to use third party or proprietary FMUs as part of the simulation, in an industrial context this would allow competing organisations to share models to develop the UAV swarm without revealing sensitive details of, for example, how their controller performs key tasks such as route finding.

5 A Unified Semantic Approach

We are developing unified foundations for the INTO-CPS languages using a framework called Unifying Theories of Programming (UTP) [19], that supports the description and unification of formal semantics for heterogeneous modelling languages. The core notation of the UTP is the alphabetised predicate calculus, that consists of the usual operators of a first-order logic, ranging over the variables of a particular model. UTP is then based around the idea that any program or model can be represented by such a predicate. For example, the operators of an imperative program can be denoted by dividing the alphabet $\alpha(P)$ of a predicate P into input variables x and output variables x' . Imperative programming operators can then be given predicative interpretations, for example assignment $x := v$ can be formally denoted by predicate $x' = v \wedge y' = y$ where y represents all other variables in the alphabet.

Unification of semantic models is achieved through isolation of “UTP theories” that describe the foundational paradigms, such as real-time, object orientation, or concurrency, and thus act as semantic “building blocks” [10]. Describing various language semantics in terms of these building blocks, also allows one to link them through the common theoretical factors. For example, we could link

$$P, Q ::= P ; Q \mid P \triangleleft B \triangleright Q \mid x := e \mid P^* \mid P^\omega \mid \langle \dot{x} = f(t, \underline{x}) \mid B \rangle \mid P[B]Q \mid \llbracket P \rrbracket$$

Table 1. Signature of hybrid relational calculus

theories of discrete and continuous real-time through an appropriate discretisation. Combination of several UTP theories then allows production of denotational semantics for a particular language. Then we can derive other semantic models, such as operational or algebraic semantics, which can be used as input for the development of tools. This will then ensure the well-foundedness of the INTO-CPS tool-chain, by allowing the evidence of several tools to be soundly composed. Our overall approach to semantics in INTO-CPS is thus to develop UTP theories that will provide the semantic building blocks, and then use these to produce formal semantic models. UTP theories are characterised by observational variables and healthiness conditions, the latter of which act as invariants on the structure of the theory. For example we have observational variables ti and ti' that represent the start and end time of a model's behaviour. A healthiness condition of such a theory is that time should proceed in a forward direction, that is $ti \leq ti'$. Healthiness conditions are usually characterised as idempotent and monotone functions, such that their images form a lattice.

CPSs are usually represented by hybrid computational models consisting of both discrete and continuous variables, and thus we first develop a UTP theory of hybrid relations [11]. In addition to discrete input and output variables this theory also provides support for continuous variable trajectories $\underline{x} : \mathbb{R} \rightarrow \mathbb{R}$. The healthiness condition for this theory is called **HCT**: it ensures that variables are piecewise continuous over a particular interval of time. The signature of the theory is shown in Table 1. It includes the standard operators of the relational calculus like sequential composition $P ; Q$, if-then-else conditional $P \triangleleft b \triangleright Q$, assignment $x := v$, finite iteration P^* , and infinite iteration P^ω . Additionally it has three operators for continuous modelling. $\langle F_n \mid B \rangle$ allows the behaviour of a continuous variables to be described by a system of differential and algebraic equations. $P[B]Q$ represents the evolution of a continuous system P which is preempted when condition B is satisfied by the continuous variable valuations, following which Q is activated. Finally, $\llbracket P \rrbracket$ is adapted from Duration Calculus [33], and states that the predicate P holds continuously over the present time interval. The final operator can be used to logically specify the behaviour of a continuous system. We exemplify the calculus with a simple example based on the classic bouncing ball.

$$h, v := 2, 0 ; \left(\left\langle \dot{h} = v; \dot{v} = -9.81 \right\rangle [h < 0] v := -v' \cdot 0.8 \right)^\omega$$

The height and velocity, h and v , are initially set to 2 and 0 respectively and the evolution of the differential equations begin. When the condition $h < 0$ becomes true, then the evolution is preempted and an assignment is executed that reverses the velocity and applies a dampening factor. Finally the whole

system iterates. We have used our hybrid relational calculus to give a semantics to a subset of Modelica, which elaborates the latter’s event handling system [11]. Moreover we have mechanised the calculus in our Isabelle based theorem prover for UTP [12], which enables automated proof about hybrid relations.

Ultimately we will use this hybrid relational calculus to produce a formal language into which the various notations used on this project can be soundly converted, and appropriate analysis performed. This will then allow the integration of the heterogeneous models and a formal description of their co-simulation in FMI. Real-time, concurrency, and rich-state modelling have already been given substantial study in the UTP within the context of the *Circus* language family [24]. *Circus* is a formal modelling language that combines the constructs of the CSP process specification language [18] for modelling concurrent systems with rich-state as provided by the *Z* notation [32]. *Circus* has been extended to enable specification of discrete real-time systems by adding constructs for modelling waiting states, timeouts, and deadlines in languages *CircusTime* [30] and *CML* [31].

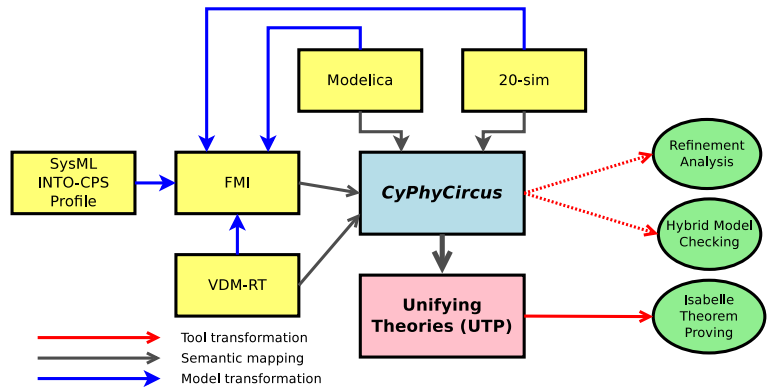

Fig. 11. INTO-CPS foundations through *CyPhyCircus*

The semantic model of *CML* will be applied to give a semantics to the real-time CPUs and threads of VDM-RT. We will model each thread, object, CPU, and bus from VDM-RT as different types of *Circus* processes. A thread, for example, will have a collection of local state variables to be synchronised with the corresponding object process variable store, by the CPU process, when sufficient time has passed. However, the existing variants of *Circus* provide only discrete time modelling, and so for INTO-CPS we are creating a further extension of *Circus* to enable modelling of CPSs in a language called *CyPhyCircus* based on our hybrid relational calculus. This will enable the description of concurrent interacting systems, as in FMI. Moreover, we will allow the modelling

of the real-time language aspects by taking direction from Timed CSP [26], and the system dynamics aspects from Hybrid CSP [17].

Figure 11 illustrates the approach, whereby models described in VDM-RT, Modelica, and 20-sim can be soundly mapped to *CyPhyCircus* processes that represent the individual FMUs. The composition of these different models, as described by FMI, is given a semantics in terms of CSP processes that provide channels to represent stepping forward and otherwise manipulating an FMU. In addition to enabling their sound unification, the use of *CyPhyCircus* as a lingua franca also enables application of various verification technologies, such as Isabelle for theorem proving.

6 Conclusions

We have presented an argument for formal model-based CPS engineering to allow the use of diverse notations, unifying them at a semantic level. The DE and CT environments have appropriate abstractions for modelling software and physical systems respectively that allow the engineer to think about what they want to model more than what form it needs for simulation. We have also shown that such a co-model can produce a result that is close to the response of the physical device. Semantic integration of diverse notations has been shown to be beneficial even for binary co-modelling with only an operational semantics for co-simulation. However, we have identified the need to scale to n-ary multi-models, and to provide the corresponding extensible semantic framework. We have shown how these features may be delivered through the use of FMI-based co-simulation in an integrated tool chain, and through the use of UTP as a vehicle for supporting theory development, enabling a range of analytic tools.

We also observe that while semantically sound co-modelling is vital for the development of dependable CPSs, it is certainly not enough on its own. There is a need for integrated development methods and tools that span from requirements through to the analysis of simulation results and the generation of software source code and test automation. Critically in this complex multi-model environment, there is a need for efficiently managing the traceability of design artefacts, both for the change impact analysis and for the managing of the evidence on which the dependability cases for CPSs will rely.

Acknowledgments. Crescendo and Symphony were developed in DESTECs (FP7, 248134), and COMPASS (FP7, 287829). Our current work is partially supported by the INTO-CPS project (Horizon 2020, 664047). We would like to thank all the participants of those projects for their efforts making this a reality.

References

1. Alur, R., Courcoubetis, C., Halbwachs, N., Henzinger, T.A., Ho, P.H., Nicollin, X., Olivero, A., Sifakis, J., Yovine, S.: The Algorithmic Analysis of Hybrid Systems. *Theoretical Computer Science* 138, 3–34 (1995)
2. van Amerongen, J.: *Dynamical Systems for Creative Technology*. Controllab Products, Enschede, Netherlands (2010)
3. Broenink, J.F., Larsen, P.G., Verhoef, M., Kleijn, C., Jovanovic, D., Pierce, K., Wouters, F.: Design Support and Tooling for Dependable Embedded Control Software. In: *Proceedings of Serene 2010 International Workshop on Software Engineering for Resilient Systems*. pp. 77–82. ACM (April 2010)
4. Broy, M., Cengarle, M.V., Geisberger, E.: Cyber-Physical Systems: Imminent Challenges. In: Calinescu, R., Garlan, D. (eds.) *Large-Scale Complex IT Systems. Development, Operation and Management*, Lecture Notes in Computer Science, vol. 7539, pp. 1–28. Springer Berlin Heidelberg (2012)
5. Camacho, E.F., Alba, C.B.: *Model Predictive Control*. Advanced Textbooks in Control and Signal Processing, Springer-Verlag London (2007)
6. Carloni, L.P., Passerone, R., Pinto, A., Sangiovanni-Vincentelli, A.L.: Languages and Tools for Hybrid Systems Design. *Foundations and Trends in Electronic Design Automation* 1(1/2) (2006)
7. Derler, P., Lee, E.A., Sangiovanni-Vincentelli, A.: Modeling Cyber-Physical Systems. *Proceedings of the IEEE (special issue on CPS)* 100(1), 13 – 28 (January 2012)
8. Fitzgerald, J., Larsen, P.G., Pierce, K., Verhoef, M.: A Formal Approach to Collaborative Modelling and Co-simulation for Embedded Systems. *Mathematical Structures in Computer Science* 23(4), 726–750 (2013)
9. Fitzgerald, J., Larsen, P.G., Verhoef, M. (eds.): *Collaborative Design for Embedded Systems – Co-modelling and Co-simulation*. Springer (2014)
10. Foster, S., Miyazawa, A., Woodcock, J., Cavalcanti, A., Fitzgerald, J., Larsen, P.: An approach for managing semantic heterogeneity in systems of systems engineering. In: *Proc. 9th Intl. Conf. on Systems of Systems Engineering*. IEEE (2014)
11. Foster, S., Thiele, B., Cavalcanti, A., Woodcock, J.: Towards a UTP semantics for Modelica. In: *6th Intl. Symposium on Unifying Theories of Programming* (2016)
12. Foster, S., Zeyda, F., Woodcock, J.: Isabelle/UTP: A mechanised theory engineering framework. In: *Proc. 5th Intl. Symp. on Unifying Theories of Programming*. LNCS, vol. 8963, pp. 21–41. Springer (2014)
13. Fritzson, P.: *Principles of Object-Oriented Modeling and Simulation with Modelica 2.1*. Wiley-IEEE Press (January 2004)
14. Gamble, C., Pierce, K.: Design patterns for use in co-modelling. In: Fitzgerald, J., Larsen, P.G., Verhoef, M. (eds.) *Collaborative Design for Embedded Systems*, pp. 319–356. Springer Berlin Heidelberg (2014)
15. Grujic, I., Nilsson, R.: Model-based development and evaluation of control for complex multi-domain systems: Attitude control for a quadrotor uav. Tech. Rep. 23, Department of Engineering, Aarhus University (January 2016)
16. Haber, A., Ringert, J.O., Rumpe, B.: MontiArc - Architectural Modeling of Interactive Distributed and Cyber-Physical Systems. Tech. Rep. AIB-2012-03, RWTH Aachen (Feb 2012)
17. He, J.: From CSP to hybrid systems. In: Roscoe, A.W. (ed.) *A classical mind: essays in honour of C. A. R. Hoare*, pp. 171–189. Prentice Hall (1994)
18. Hoare, T.: *Communication Sequential Processes*. Prentice-Hall International, Englewood Cliffs, New Jersey 07632 (1985)
19. Hoare, T., Jifeng, H.: *Unifying Theories of Programming*. Prentice Hall (April 1998)

20. Kesten, Y., Pnueli, A.: Timed and hybrid statecharts and their textual representation. In: Vytopil, J. (ed.) *Formal Techniques in Real-Time and Fault-Tolerant Systems, Second International Symposium*, Nijmegen, The Netherlands, January 8–10, 1992, Proceedings. *Lecture Notes in Computer Science*, vol. 571, pp. 591–620. Springer (1992)
21. Kleijn, C.: Modelling and Simulation of Fluid Power Systems with 20-sim. *Intl. Journal of Fluid Power* 7(3) (November 2006)
22. Larsen, P.G., Battle, N., Ferreira, M., Fitzgerald, J., Lausdahl, K., Verhoef, M.: The Overture Initiative – Integrating Tools for VDM. *SIGSOFT Softw. Eng. Notes* 35(1), 1–6 (January 2010), <http://doi.acm.org/10.1145/1668862.1668864>
23. Lee, E.A.: Computing needs time. *Communications of the ACM* 52(5), 70–79 (May 2009)
24. Oliveira, M., Cavalcanti, A., Woodcock, J.: A UTP semantics for Circus. *Formal Aspects of Computing* 21, 3–32 (February 2009)
25. Peleska, J.: Industrial-Strength Model-Based Testing - State of the Art and Current Challenges. *Electronic Proceedings in Theoretical Computer Science* abs/1303.1006, 3–28 (2013)
26. Reed, G., Roscoe, A., et al.: Timed CSP: Theory and Practice. In: *REX Workshop - Real Time: Theory and Practice*, LNCS. Springer-Verlag (1992)
27. OMG Systems Modeling Language (OMG SysML™). Tech. Rep. Version 1.4, Object Management Group (September 2015), <http://www.omg.org/spec/SysML/1.4/>
28. Verhoef, M., Larsen, P.G., Hooman, J.: Modeling and Validating Distributed Embedded Real-Time Systems with VDM++. In: Misra, J., Nipkow, T., Sekerinski, E. (eds.) *FM 2006: Formal Methods*. pp. 147–162. *Lecture Notes in Computer Science* 4085, Springer-Verlag (2006)
29. Wang, B., Baras, J.S.: HybridSim: A Modeling and Co-simulation Toolchain for Cyber-physical Systems. In: *17th IEEE/ACM International Symposium on Distributed Simulation and Real Time Applications, DS-RT 2013*, Delft, The Netherlands, October 30–November 1, 2013. pp. 33–40. IEEE Computer Society (2013)
30. Wei, K., Woodcock, J., Cavalcanti, A.: Circus Time with Reactive Designs. In: *Unifying Theories of Programming*. LNCS, vol. 7681, pp. 68–87. Springer (2013)
31. Woodcock, J.: Engineering UToPiA - Formal Semantics for CML. In: Jones, C., Pihlajasaari, P., Sun, J. (eds.) *FM 2014: Formal Methods*. *Lecture Notes in Computer Science*, vol. 8442, pp. 22–41. Springer (2014)
32. Woodcock, J., Davies, J.: *Using Z – Specification, Refinement, and Proof*. Prentice Hall International Series in Computer Science (1996)
33. Zhou, C., Hoare, C.A.R., Ravn, A.P.: A calculus of durations. *Information Processing Letters* 40(5), 269–276 (1991)