



Deposited via The University of Leeds.

White Rose Research Online URL for this paper:

<https://eprints.whiterose.ac.uk/id/eprint/97973/>

Version: Accepted Version

Proceedings Paper:

Konpang, J, Sandhu, M, Somjit, N et al. (2017) Novel RF Interference Rejection Technique using a Four-port Diplexer. In: Proceedings of the 46th European Microwave Conference (EuMC 2016). European Microwave Week 2016, 04-06 Oct 2016, London, UK. IEEE, pp. 524-527. ISBN: 978-2-87487-043-9.

<https://doi.org/10.1109/EuMC.2016.7824395>

© 2016 IEEE. Personal use of this material is permitted. Permission from IEEE must be obtained for all other uses, in any current or future media, including reprinting/republishing this material for advertising or promotional purposes, creating new collective works, for resale or redistribution to servers or lists, or reuse of any copyrighted component of this work in other works.

Reuse

Items deposited in White Rose Research Online are protected by copyright, with all rights reserved unless indicated otherwise. They may be downloaded and/or printed for private study, or other acts as permitted by national copyright laws. The publisher or other rights holders may allow further reproduction and re-use of the full text version. This is indicated by the licence information on the White Rose Research Online record for the item.

Takedown

If you consider content in White Rose Research Online to be in breach of UK law, please notify us by emailing eprints@whiterose.ac.uk including the URL of the record and the reason for the withdrawal request.

Novel RF Interference Rejection Technique using a Four-port Diplexer

Jessada Konpang, Muhammad Sandhu, Nutapong Somjit and Ian Hunter

Institute of Microwaves and Photonics,
School of Electronic and Electrical Engineering,
University of Leeds,
Leeds, LS2 9JT, UK

Abstract—A novel RF interference rejection technique using four-port network is presented in this paper by using two diplexers combined together. This technique offers the signal isolation of 68.46 dB between transmitter and receiver module, which is the best figure ever reported. The four-port network exploits both high and low-Q factor filters for the cost reduction. The design tolerance with phase deviation between 180° and 183° of four-port network was investigated and the novel concept still has signal isolation (S_{32}) of better than 65.47 dB, which is still superior compared to the existing diplexer. Finally, RF interference rejection technique can be used in wireless communication systems whereas small size, low losses and low complexity are required.

Keywords—four-port network; lumped element; diplexer; high isolation

I. INTRODUCTION

The recent advance of radio frequency (RF) and microwave technology has stimulated the rapid development of modern wireless communication systems. For the last few decades, a variety of techniques used to design bandpass filters were developed e.g. lumped-elements (LC Circuit), microstrip configurations, coaxial configurations, dielectric filters, cavity resonator and high temperature superconductors [1, 2]. In microwave system, it is challenging to design a device at low cost and high performance. The design of different filters and diplexers was discussed in [3-4] which conventional diplexers offer low cost (microstrip structure) but give poor isolation performance (worse than 20dB) and high losses. Consequently, a new technique to improve signal isolation while keeping low signal losses is required. Diplexers are three-port network and commonly used to combine or separate different signal frequencies which they are usually set in the form of filters. RF front-end of a cellular radio base station uses bandpass filters to discriminate two different frequency bands for transmitting (Tx) and receiving (Rx) channels using a single antenna as shown in Fig. 1. Generally, relatively high power signals, in an order of 30 W, are generated by Tx channel. Consequently, the Tx filter should have high capability of power handling and the receiver Rx channel has to detect very weak signals [5].

Therefore, in order to protect the low-noise amplifier in the receiver channel from the transmitter channel with high power signals (30 W), the Rx filter is designed to have high signal isolation between the two channels because transmit power amplifier produces out-of-band intermodulation products and

harmonics [5]. In the transmitting band, Tx filter also has a high level of stopband attenuation to reject the noise generated at the output of the power amplifier. For this reason, diplexer with high isolation between Tx and Rx channels is required.

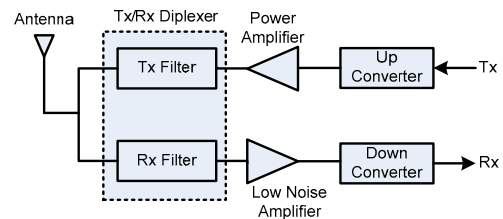

Fig. 1. RF front-end of a cellular base station.

In this paper, a novel RF interference rejection technique using four-port network is introduced as a superior design technique for the high-isolation at lower cost compared to the state-of-the-art diplexer devices. The proposed four-port network combines bandpass filters with high and low-Q factor for the cost reduction and device miniaturization while offering superior RF performance.

II. ANALYSIS OF THREE-PORT AND FOUR-PORT NETWORKS

For a lossless and reciprocal network, the unitary condition of network can be shown as [5]:

$$[S][S^*]=[1] \quad (1)$$

Consider the three-port network shown in Fig. 2, the scattering matrix can be described:

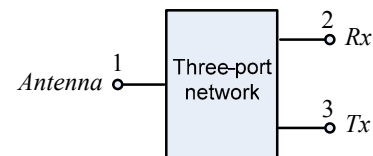

Fig. 2. A three-port network.

$$\begin{bmatrix} S_{11} & S_{12} & S_{13} \\ S_{21} & S_{22} & S_{23} \\ S_{31} & S_{32} & S_{33} \end{bmatrix} \begin{bmatrix} S_{11}^* & S_{12}^* & S_{13}^* \\ S_{21}^* & S_{22}^* & S_{23}^* \\ S_{31}^* & S_{32}^* & S_{33}^* \end{bmatrix} = [1] \quad (2)$$

$$S_{12}S_{13}^* + S_{22}S_{23}^* + S_{23}S_{33}^* = 0 \quad (3)$$

We wish $S_{23} = \epsilon \ll 1$ in Tx band and we also consider $S_{13} \cong 1$ for low loss. From (3), $S_{12} \cdot 1 + S_{22} \cdot \epsilon^* + \epsilon \cdot S_{33}^* = 0$. Now

That is, a degree 2 transfer function at least must be used.

The ripple level ε is

$$\varepsilon = (10^{L_R/10} - 1)^{-1/2} = 0.1005 \quad (22)$$

The doubly loaded normalised lowpass prototype filter element values (g_i) can be calculated as [6]

$$g_1 = \frac{2a_1}{\gamma} \quad (23)$$

$$g_i = \frac{4a_{i-1}a_i}{b_{i-1}g_{i-1}}, \quad i = 2, 3, \dots, N \quad (24)$$

$$g_{N+1} = 1 \text{ for } N \text{ odd} \\ = \coth^2\left(\frac{\beta}{4}\right) \text{ for } N \text{ even} \quad (25)$$

Where

$$\beta = \ln\left(\coth\frac{L_R}{L_{17.37}}\right) \quad (26)$$

$$\gamma = \sinh\left(\frac{\beta}{2N}\right) \quad (27)$$

$$a_i = \sin\left[\frac{(2i-1)\pi}{2N}\right], \quad i = 1, 2, \dots, N \quad (28)$$

And

$$b_i = \gamma^2 + \sin^2\left(\frac{i\pi}{N}\right), \quad i = 1, 2, \dots, N \quad (29)$$

Therefore, the calculated element values of a second order Chebyshev filter are given as $g_0=1$, $g_1=0.843$, $g_2=0.622$ and $g_3=1.3554$. The normalized external couplings coefficients are calculated as $k_e = \frac{1}{\sqrt{g_0g_1}} = \frac{1}{\sqrt{g_Ng_{N+1}}}$ (30)

And the internal couplings are calculated as

$$k_{i,i+1} = \frac{1}{\sqrt{g_i g_{i+1}}}, \quad i = 1, 2, \dots, N-1 \quad (31)$$

The normalized coupling coefficient can be represented in terms of coupling bandwidths

$$K_{i,i+1} = \frac{1}{\sqrt{g_i g_{i+1}}} * \text{Bandwidth (GHz)} \quad (32)$$

The inductor used to realize external impedance inverter of the bandpass filter can be calculated from the relation [6].

$$L_e = \frac{Z_0}{\pi \sqrt{2\pi f_0(\text{GHz})} K_e(\text{GHz})} \text{ nH} \quad (33)$$

The inductor is used to form of impedance inverter between adjacent resonators of the bandpass filter as shown in Fig. 5. It can be calculated as from the [6].

$$L_{ij} = \frac{Z_0}{\pi^2 K_{ij}(\text{GHz})} \text{ nH} \quad (34)$$

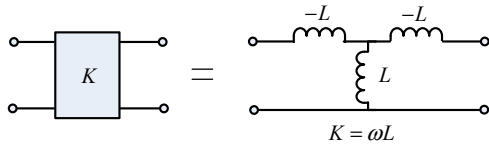

Fig. 5. Equivalent circuit of impedance inverter.

The element values of shunt resonator with centre frequency and the system impedance level of 50Ω can be calculated as [7].

$$C = \frac{1}{4f_0(\text{GHz})Z_0} \text{ nF} \quad (35)$$

And

$$L = \frac{Z_0}{\pi^2 f_0(\text{GHz})} \text{ nH} \quad (36)$$

IV. DESIGN EXAMPLE AND RESULTS

The diplexer (three-port) design is based on the independent design of two bandpass filters as following steps.

Step 1: design filter in Tx between port 1 and 3 at centre frequency of 1.73 GHz with 50 MHz bandwidth.

Step 2: calculate the external and internal coupling coefficients as equation (30) and (31).

Step 3: calculate the shunt resonator elements as equation (35) and (36).

Step 4: design filter in Rx between port 1 and 2 at centre frequency of 2.13 GHz with 50 MHz bandwidth which is the same steps as in Tx.

Then, the T-junction is connected the two independent bandpass filters together. The circuit of the inverter coupled diplexer network is shown in Fig. 6. The external coupling coefficients are $K_{T1} = 0.322$ and $K_{R1} = 0.289$. The internal coupling coefficients are $K_{T12} = 0.084$, $K_{R12} = 0.082$. The element values of shunt resonator are $L_{11} = 2.3784$ nH, $L_{22} = 2.9284$ nH, $C_{11} = 2.3474$ pF, $C_{22} = 2.8902$ pF. The inverter coupled three-port network simulated response by AWR microwave office is portrayed in Fig. 7. The 20-dB bandwidth is 50 MHz. The passband IL in Tx band is less than 0.22 dB and Rx band 0.31 dB. The RL in both channels is better than 20 dB in the passband.

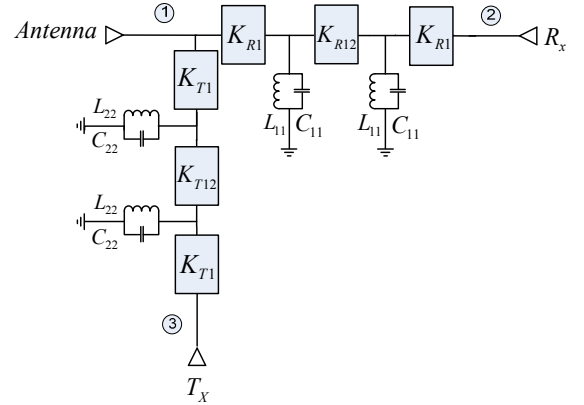

Fig. 6. Inverter coupled diplexer layout.

From Fig.4, two diplexer filters (diplexer 1 and 2) are combined together in order to obtain the best isolation. The first diplexer (No. 1, 2 and 3) is designed with High-Q factor ($Q=1000$). The second diplexer (No. 2, 3 and 4) is designed with Low-Q factor ($Q=500$). The circuit of the inverter coupled four-port network is shown in Fig. 8. The inverter coupled four-port network simulated response is portrayed in

Fig. 9. The RL in both channels is better than 20 dB in the passband. The passband IL in Tx band is less than 0.23 dB and Rx band 0.32 dB. It can be seen that both three-port and four-port network are almost the same insertion loss. The comparison isolation (S_{32}) of three-port and four-port is shown in Fig. 10. The simulated isolation of diplexer network is 35.66 dB and 68.46 dB in four-port. From Fig. 10, it can be seen that the phase shift between 180° and 183° of four-port network still has signal isolation (S_{32}) better than the existing diplexer.

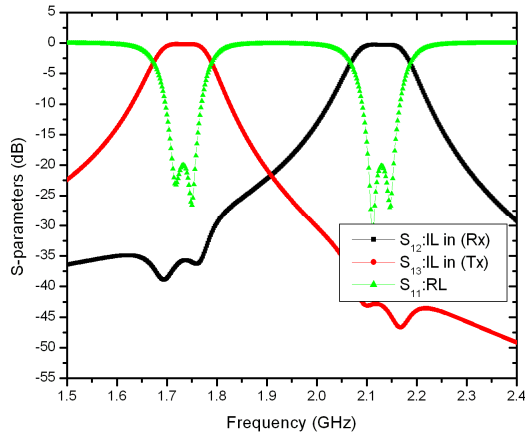

Fig. 7. Inverter coupled lumped element diplexer network response.

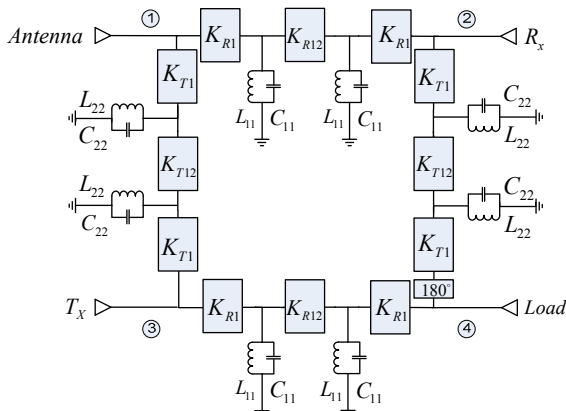

Fig. 8. Inverter coupled four-port layout.

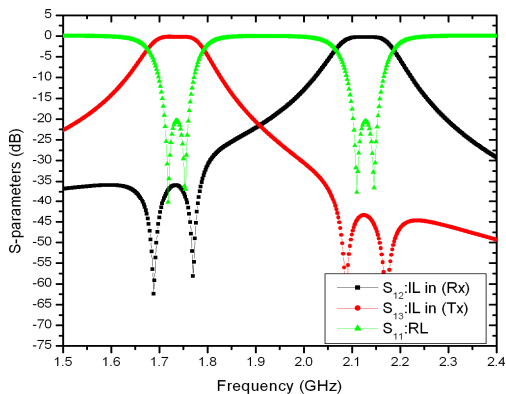

Fig. 9. Inverter coupled lumped element four-port network response.

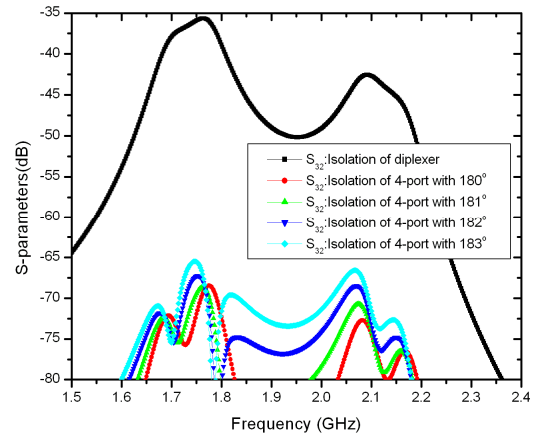

Fig. 10. Comparison of isolation (S_{32}) response of diplexer and four-port network.

V. CONCLUSIONS

The novel RF interference rejection techniques using a four-port diplexer is proposed here. The concept is very attractive since the four-port network is based on the design of two independent diplexer bandpass filters, (Tx at 1.73 GHz, Rx at 2.13 GHz, BW=50MHz): one of them meeting the desired High-Q ($Q=1000$) and the other desired Low-Q ($Q=500$). The new technique design can enhance the isolation (S_{32}) from (35.66 dB) to (68.46 dB). Finally, RF interference rejection technique can be used in wireless communication systems whereas small size, low losses and low complexity are required.

REFERENCES

- [1] J.-S. G. Hong and M. J. Lancaster, *Microstrip filters for RF/microwave applications* vol. 167: John Wiley & Sons, 2004.
- [2] I. C. Hunter, L. Billonnet, B. Jarry, and P. Guillon, "Microwave filters-applications and technology," *Microwave Theory and Techniques, IEEE Transactions on*, vol. 50, pp. 794-805, 2002.
- [3] Han-Sam Peng and Yi-Chyun Chiang, "Microstrip Diplexer Constructed With New Types of Dual-Mode Ring Filters," *IEEE Microwave and Wireless Components Letter*, vol. 25, pp. 7-9, 2015.
- [4] Q. Xue and J.-X. Chen, "Compact diplexer based on double-sided parallel-strip line," *Electronics Letter*, vol. 44, pp. 123-124, 2008.
- [5] I. Hunter, *Theory and design of microwave filters*: IET, 2001.
- [6] P. N. Martin, J., "Coupling Bandwidth and Reflected Group Delay Characterization of Microwave Bandpass Filters," *Applied Microwave and wireless*, vol. 11, 1999.
- [7] G. Matthaei, L. Young, and E. Jones, "Microwave filters, Impedance matching networks and coupling Structure," Norwood, MA, Artech House, 1980.