



UNIVERSITY OF LEEDS

This is a repository copy of *Experimental Study and Analytical Study of Push-out Shear Tests in Ultra Shallow Floor Beams*.

White Rose Research Online URL for this paper:
<http://eprints.whiterose.ac.uk/80994/>

Version: Accepted Version

Proceedings Paper:

Huo, BY, D Mello, C and Tsavdaridis, KD (2010) Experimental Study and Analytical Study of Push-out Shear Tests in Ultra Shallow Floor Beams. In: IABSE Symposium Report. IABSE Symposium, 22-24 September 2010, Venice, Italy. International Association for Bridge and Structural Engineering , 31 - 38.

<https://doi.org/10.2749/222137810796024051>

Reuse

Unless indicated otherwise, fulltext items are protected by copyright with all rights reserved. The copyright exception in section 29 of the Copyright, Designs and Patents Act 1988 allows the making of a single copy solely for the purpose of non-commercial research or private study within the limits of fair dealing. The publisher or other rights-holder may allow further reproduction and re-use of this version - refer to the White Rose Research Online record for this item. Where records identify the publisher as the copyright holder, users can verify any specific terms of use on the publisher's website.

Takedown

If you consider content in White Rose Research Online to be in breach of UK law, please notify us by emailing eprints@whiterose.ac.uk including the URL of the record and the reason for the withdrawal request.



eprints@whiterose.ac.uk
<https://eprints.whiterose.ac.uk/>

Experimental and Analytical Study of Push-out Shear Tests in Ultra Shallow Floor Beams

Bing Yu HUO
PhD Candidate
City University, London
United Kingdom
bing.huo.1@city.ac.uk

Bing Yu Huo, received his Bachelor Degree (Hons) of Civil Engineering from City University London. The topic of his PhD research is strength and performance of innovative shear connectors of Ultra Shallow Floor Beams.

Cedric D'MELLO
Associate Dean
City University, London
United Kingdom
C.A.D'Mello@city.ac.uk

Cedric D'Mello, obtained his undergraduate and doctoral degrees in Structural Engineering from the University of Sussex. His main research interests are in the areas of composite structures and testing of large scale civil engineering structures.

Konstantinos-Daniel TSAVDARIDIS
PhD Candidate, City
University, London, UK
ds016@city.ac.uk

K.D. Tsavdaridis, received his BEng degree in Civil Engineering from City University and MSc (DIC) degrees in Structural Engineering from Imperial College, London. His PhD research is on the failure criteria of perforated steel beam with various shapes of web openings.

Summary

The Ultra Shallow Floor Beam is a new type of composite floor beam fabricated by welding two highly asymmetric cellular tees together along the web and incorporating a concrete slab between the top and bottom flanges. The unique features of this system are circular and elongated web openings that allow tie-bars, building services and ducts passing through the structural depth of the beam. For the composite beam in bending, the longitudinal shear force is transferred by a unique shear mechanism which results from the special configuration of the beam, and shear connectors, if they are present. The work reported in this paper includes a total of 16 full-scale push-out tests aimed at investigating the longitudinal shear behaviour of these beams and the effects of additional shear connectors. A theoretical analysis was also performed to investigate the failure mechanism of the system.

Keywords: shear connectors; web openings; shallow floor beam; push-out test; experimental study; theoretical analysis.

1. Introduction

In recent years, there are increasing demands for composite beam of shallow depth for use in multi-storey building in the urbanized area. For conventional composite floor beams or downstand composite beams, the thickness of the flanges increases with the increase of span of the steel section. Consequently, the steel sections are often heavier than needed [1]. The Ultra Shallow Floor Beam (USFBTM), developed by Westok Limited UK, is a new type of composite floor beam, which is fabricated by welding two highly asymmetric cellular tees together along the web. Precast concrete floor units or profiled steel decking sits on the bottom flange [2], as shown in Figure 1. The top and bottom tees are cut from

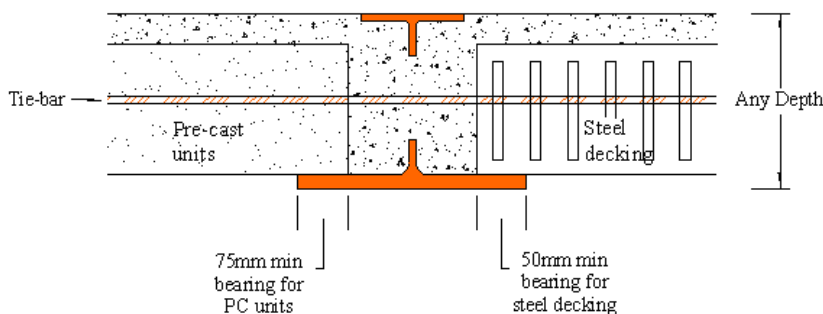

Fig. 1: Schematic drawing of cross-

reinforcing tie-bars, building services and ducting through structural depth of the beam, hence minimising the overall floor depth. Full service integration can be achieved when deep profiled steel decking is employed, as pipes or ducts pass

different parent sections; the top tee is much smaller than the bottom tee. This asymmetric section property reduces the weight of the beam with a smaller top tee and also increases the moment capacity with a bigger bottom tee.

Circular and elongated web openings provide a passage for

through between the ribs of the decking. The construction details for precast concrete floor units and profiled steel decking are shown in Figure 2 and 3, respectively.



Fig. 2: USFB™ used with precast



Fig. 3: USFB™ used with profiled

As the floors are being cast, the in-situ concrete passes through the web openings, which may or may not include a tie-bar or duct. This concrete plug and tie bar forms a unique mechanism for transferring longitudinal shear force along the beam. The aim of this research is to investigate the behaviour and properties of this shear transfer mechanism by conducting a series of push-out tests.

2. Objectives

In order to provide information on the behaviour and properties of this unique shear transfer the objectives of this research are as follows:

- To design specimens for push-out tests that represent the actual shear behaviour;
- To design the push-out tests that reflect the desired loading condition and are also in compliance with the specifications of the Eurocode 4 (EN 1994-1-1:2004);
- To analyse the characteristic behaviour of these shear connectors from the load-slip curves;
- To carry analyse the test results and propose a conceptual model and design approach for this shear behaviour.

3. Unique Shear Resistance behaviour

The fundamental purpose of the shear connection is to transfer the longitudinal shear force and to resist the transverse separation force. The shear connectors used in the USFB™ are different in form compared with conventional shear studs. They innovatively incorporate the circular or elongated web opening features of the beam. Four different types of shear connectors were investigated: concrete-infill-only, tie-bar, ducting and horizontal shear-stud connectors.

3.1 Concrete-infill-only Shear Connector

Where the web openings have no tie-bar, building services or ducting present, the in-situ concrete would completely fill the web openings. The concrete infill element interacts with the steel web post, hence transferring the longitudinal shear force needed for composite action. This type of shear connector is called concrete-infill-only shear connector.

3.2 Tie-bar Shear Connector

One of the functions of the tie-bar is to provide a tie force for the concrete slabs on both sides of the web. Generally, high yield reinforcement is used, passing through web opening. The in-situ concrete infilling the web opening acts with the tie-bar to form the tie-bar shear connector.

3.3 Ducting Shear Connector

The ventilation or air-conditioning ducting passing through the web openings provides service integration. Generally, there is void between the duct and the web opening and in-situ concrete fills these voids. The concrete infill together with the ducting forms the ducting shear connector.

3.4 Horizontal Shear-stud Connector

The horizontal shear-stud connector of the USFB™ is comprised of shear studs welded on the web post of the top tee, as illustrated in Figure 4. The shear studs act together with the concrete infill element, transferring longitudinal shear. The combination of shear studs and the concrete infill element is called horizontal shear-stud connector.

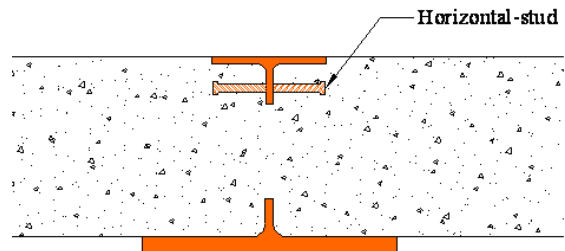

Fig. 4: Horizontal shear-stud

4. Push-out Tests

The push-out test is an elemental test applying direct shear force to the shear connectors. The characteristic behaviour and shear resisting properties of the shear connectors are examined. A series of push-out tests were carried out to investigate each type of innovative shear connector.

4.1 Design Details of Test Specimens

The steel sections used for the push-out test specimens were universal columns with three circular openings fabricated on the web post, as shown in Figure 5. The use of a symmetric section was to prevent eccentric loading of the specimen. Two sizes of the web openings, Ø150mm and Ø200mm, were used with the steel sections 254x254x73UC and 305x305x97UC, respectively. This enables the study of the relationship between diameters of the web opening and shear resistance.

Two types of concrete material were used for the slabs, normal and fibre-reinforced (synthetic fibre) concrete. The latter has a higher tensile strength than that of former.

Brief descriptions, numbering and dimensions of the specimens are summarised in Table 1.



Fig. 5: The steel section

Table 1: Brief descriptions and numbering of the specimens

Test group	Web opening	Concrete type	Specimen No.	Width of slabs (mm)	Slab Depth (mm)**	Total height of specimen (mm)
T1*	Ø150mm (A)	Normal (N)	T1-A-N	600	254	1150
T2		Fibre-reinforced (F)	T1-A-F			
T3	Ø200mm (B)	Normal (N)	T1-B-N	600	308	1200
T4		Fibre-reinforced (F)	T1-B-F			

* T1 concrete-infill-only T2 tie-bar T3 ducting T4 horizontal shear-stud
 ** The slabs surfaces are flush with the flanges of the steel section.

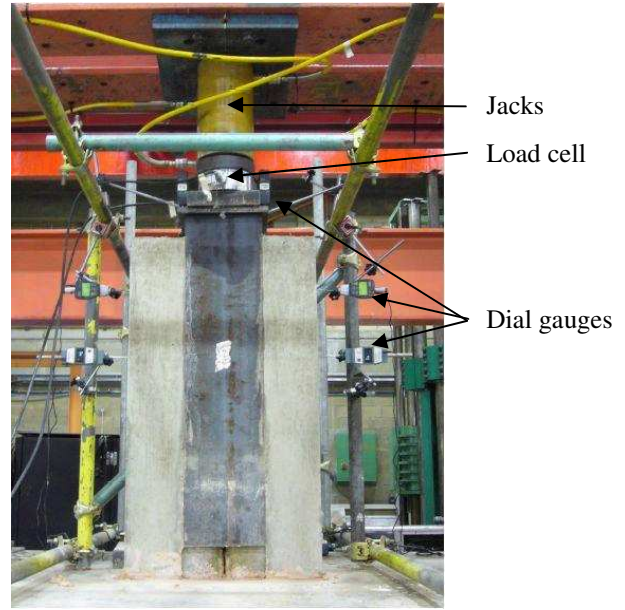

Fig. 6: The testing rig and set up

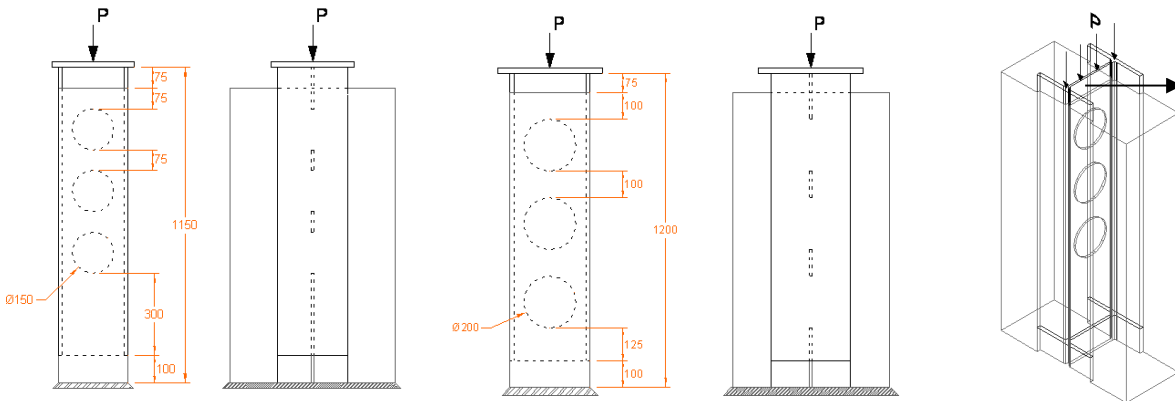

Fig. 7: Drawings of test T1

4.2 Test Procedure

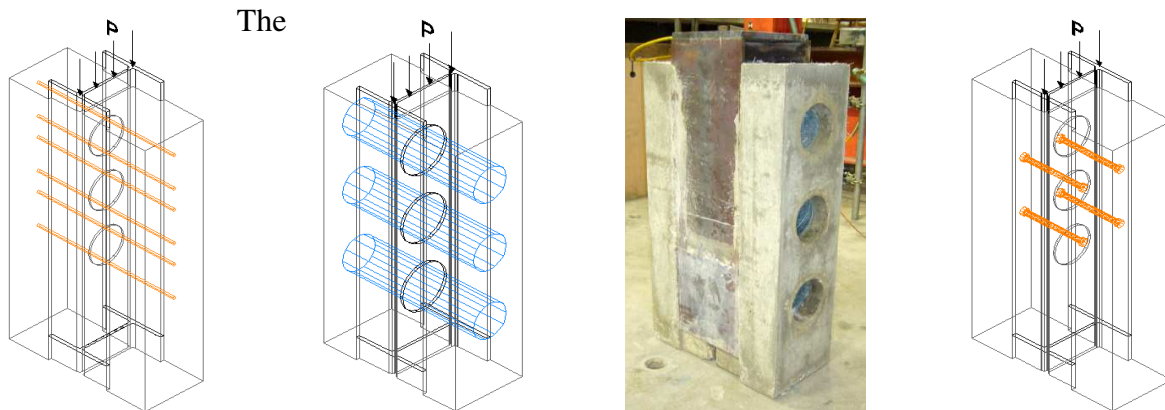

Fig. 8: 3-D drawings of specimens of test T2 (tie-bar), T3

push-out tests were carried out in the Structure Laboratory of City University London. The test rig and set up is shown in Figure 6. Two identical hydraulic jacks were used to apply load, with combined capacity

of 1800 kN. Load levels were measured using load cells and the longitudinal slip and transverse separation were measured using dial gauges of 0,01mm resolution.

Prior to the tests, the specimens were bedded in using a layer of gypsum plaster, which resulted in an even contact with the reaction plate. The incremental monotonic load was applied; the duration

of the push-out tests were around 2-3 hours, which are satisfied with the requirement of not less than 15 minutes duration, specified in the Eurocode 4 [4].

5. Test Results

5.1 Load-slip curves

The load-slip curves obtained from the push-out tests represent the characteristic behaviour of the shear connectors. Load-slip curves of specimens of each test group are shown in Figure 9, 10, 11 and 12. The load shown in the figures is the load per shear connector (or opening).

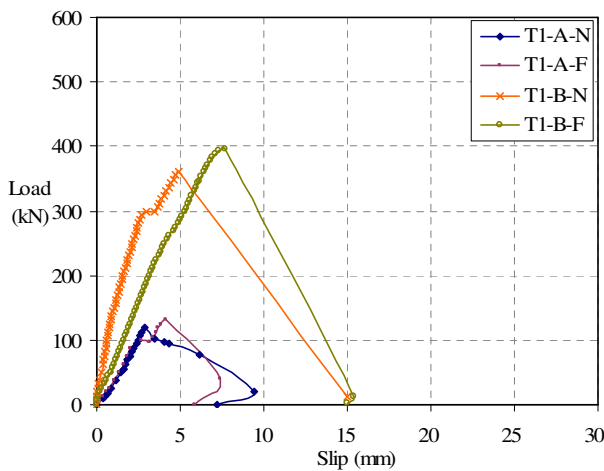

Fig. 9: Load-slip curves of test group T1, concrete-infill-

5.2

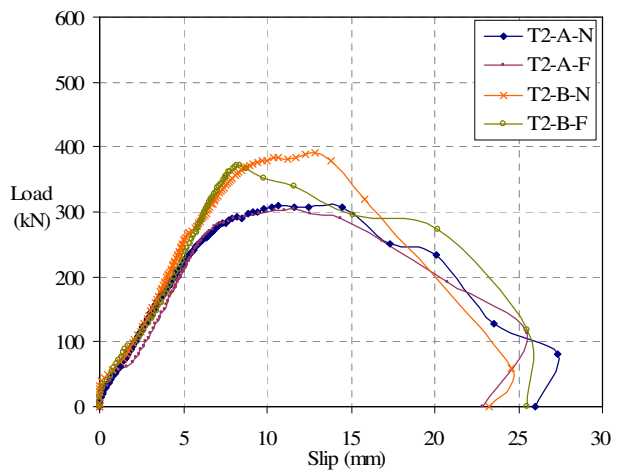

Fig. 10: Load-slip curves of test group T2, tie-bar shear

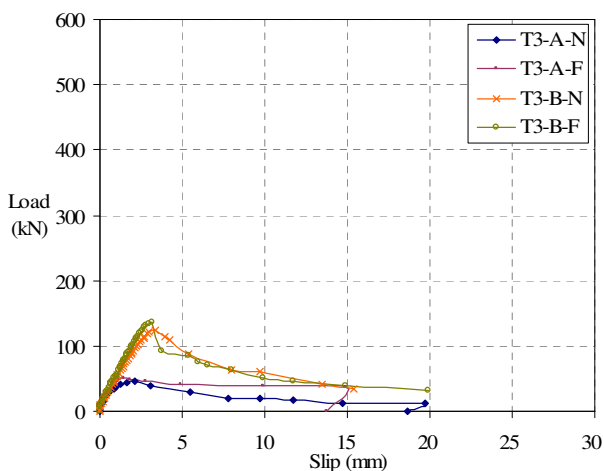

Fig. 11: Load-slip curves of test group T3, ducting shear

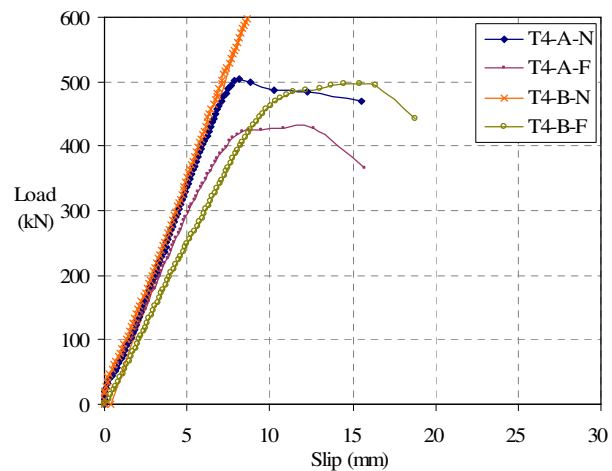

Fig. 12: Load-slip curves of test group T4, horizontal shear-

Behaviour analysis

5.2.1 Behaviour of concrete-infill-only shear connector, (T1)

Uniform behaviour of the shear connector is seen in all four specimens. The shear connector deforms elastically up to its ultimate load without any plastic deformation before fracturing as the ultimate load was reached. Specimen T1-B-N shows a local bond failure at around 300 kN, which caused a sudden increase in slip but it did not cause the entire failure of the specimen. The behaviour illustrates the brittle failure mode of these shear connectors; it is mainly due to the brittle material properties of the concrete, as the shear connectors consist of concrete only.

Examination of the specimens post-test showed that the cause of the failure of concrete-infill

element was due to the tensile failure in the transverse direction, and also due to crushing failure of a small part of concrete in the vicinity of the steel web, in the direction of shear force.

5.2.2 Behaviour of tie-bar shear connector, (T2)

The tie-bar shear connectors demonstrated significant ductile behaviour when compared to the concrete-infill-only shear connector. Plastic deformations were observed pre and post ultimate load. Large amount of slips were induced during the plastic deformations. The examination of the failed specimens showed one of the two tie-bars of each connector failed in shear. This is due to the direct contact with the web and the relative movement of the two.

5.2.3 Behaviour of ducting shear connector, (T3)

The behaviour of the ducting shear connectors is very similar to that of concrete-infill-only shear connectors. Elastic deformations were observed up to the ultimate load but the ducting shear connectors show post failure strength with extensive slip. This was due to the presence of the duct resisting the vertical movement of the steel section. Failure of the duct itself also occurred.

5.2.4 Behaviour of horizontal shear-stud connector, (T4)

Uniform behaviour was shown by three of the specimens. Elastic deformation was followed by plastic deformations and post failure plastic deformation. This behaviour is very similar to that of tie-bar shear connectors but with higher loads. Studs were sheared off towards the end of the test. Specimen T4-B-N was not tested to failure as the capacity of the jacks was reached.

5.3 Evaluation of Results

The properties of the shear connectors were evaluated from the results of the push-out tests, and are summarised in Table 3. The concrete strength of the specimens is listed in Table 2.

Table 2: Concrete strength of the specimens

Specimen No.	Compressive Strength (MPa)	Tensile Strength (MPa)	Specimen No.	Compressive Strength (MPa)	Tensile Strength (MPa)
T1-A-N	56,5	4,53	T3-A-N	55,2	3,91
T1-A-F	58,1	4,85	T3-A-F	51,5	3,89
T1-B-N	56,5	4,53	T3-B-N	55,2	3,91
T1-B-F	58,1	4,85	T3-B-F	51,5	3,89
T2-A-N	54,5	4,54	T4-A-N	67	4,66
T2-A-F	51,9	4,07	T4-A-F	50,2	4,08
T2-B-N	54,5	4,54	T4-B-N	67	4,66
T2-B-F	51,9	4,07	T4-B-F	50,2	4,08

- The ultimate shear capacity, P_u , is the maximum load reached by the push-out test specimen divided by the number of shear connectors (openings).
- The slip capacity, σ_u , is the slip value when the load level has dropped 10% below the maximum load level [4]. Where the shear connectors have no plastic deformation after maximum load is reached, the slip capacity is the slip value at the maximum load level (for the concrete-infill-only (test T1) and ducting (test T3) shear connectors).
- Characteristic slip capacity, σ_{uk} , is the slip capacity reduced by 10%. If it is greater than 6mm, the shear connector is classified as ductile [4]; furthermore, the load-slip curve of the shear connector should show plastic deformation after the maximum load is reached.
- Tie forces resisting the transverse separation were checked based on a transverse separation at 80% of the maximum load being less than $\frac{1}{2}$ of the slip [4].

Table 3: Result evaluations of the shear connectors of all specimens

Specimen No.	Ultimate shear capacity, P_{us} , (kN)	Slip capacity, σ_u , (mm)	Characteristic slip capacity, σ_{uk} , (mm)	Stiffness, K , (kN/mm)	Ductility classification (pass/fail)	Tie resistance check (pass/fail)
T1-A-N	118	2,85	2,57	41	Fail	Pass
T1-A-F	131	4,09	3,68	40	Fail	Pass
T1-B-N	362	4,92	4,43	74	Fail	Pass
T1-B-F	397	7,70	6,93	62	Fail	Pass
T2-A-N	309	16,00	14,40	45	Pass	Pass
T2-A-F	305	15,50	14,00	49	Pass	Pass
T2-B-N	390	14,70	13,30	50	Pass	Pass
T2-B-F	372	12,20	11,00	47	Pass	Pass
T3-A-N	47	2,07	1,86	31	Fail	Pass
T3-A-F	50	1,45	1,31	35	Fail	Pass
T3-B-N	125	3,37	3,03	37	Fail	Pass
T3-B-F	137	3,21	2,89	43	Fail	Pass
T4-A-N	504	8,11	7,30	66	Pass	Pass
T4-A-F	427	14,80	13,32	58	Pass	Pass
T4-B-N	--	--	--	70	--	--
T4-B-F	497	14,40	13,00	49	Pass	Pass

6. Analysis of Results

The tested specimens were examined after failure and in particular the failure profiles of the concrete infill elements. A small part of the concrete infill element was crushed by the direct shear force but the majority of the concrete failed by the tensile splitting force in the transverse direction. Figure 13 is a fibre-reinforced concrete specimen that illustrates clearly that the fibres were stretched in the transverse direction. Hence, the failure mechanism of the concrete infill element is a combination of crushing failure in the direction of the shear force and tensile splitting the transverse direction.

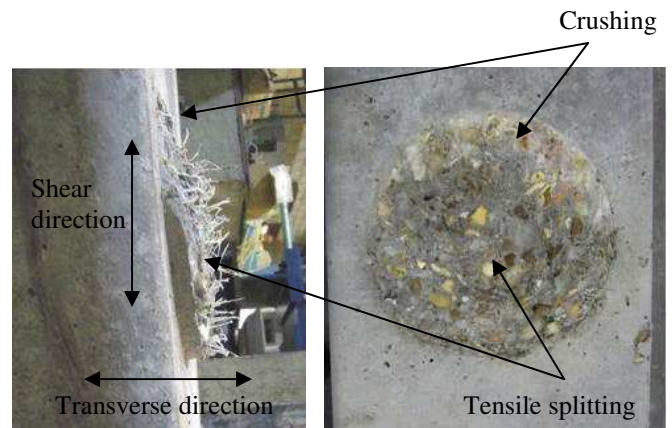

Fig. 13: Failure profile of concrete

An analysis on the results was carried out taking account of concrete crushing strength (compression) in the direction of shear, tensile strength in the transverse direction and additional strength of the tie-bar or stud. An empirical formula was derived from the analysis and shown as Equation (1). This formula can be used as a design calculation for the shear capacity of the shear connector. A safety factor of 1,5 was included in the equation. Equation (1) is conservatively 20% below the test results. Hence, Equation (1) is proposed as a conceptual design model for the innovative shear connectors used in the USFBTM.

$$P_{uc} = \frac{\left[2f_{ct} \left(\frac{\pi D^2}{4} \right) + 1,5 f_{cu} (tD) + R_{add} \right]}{1,5} \quad (1)$$

Where, P_{uc} is the design shear resistance of the shear connector;
 f_{ct} is the tensile splitting strength of concrete;
 f_{cu} is the compressive strength of concrete;
 D is the diameter of the web opening;
 t is the thickness of the web;
 R_{add} is the additional resistance of tie-bar or studs.

7. Conclusions

Four types of innovative shear connectors were investigated by conducting 16 push-out tests. The test results were analysed and the following conclusions were reached:

- (1) Uniform behaviour was shown by each type of the shear connectors. The behaviour of concrete-infill-only and ducting shear connectors is very similar; no plastic deformation was observed before the ultimate load capacity was achieved. Concrete-infill-only shear connectors illustrated a distinctive brittle failure mode. The behaviour of tie-bar and horizontal shear-stud connectors is very similar, with plastic deformations occurring before and after the ultimate load was reached. A ductile failure mode with extensive slip was also shown by the both shear connectors.
- (2) The use of studs and tie-bar increases the shear capacity, ductility and slip capacity of the shear connectors. The shear capacity of shear connectors increases with increasing diameters of the web opening and with the higher strengths of concrete infill.
- (3) Following the analysis of the results an empirical formula was proposed for the shear capacity and can be used in design calculations.

8. Recommendations

- (1) It is recommended that, because of the brittle failure mode, concrete-infill-only shear connector should not be used as the sole means of providing the shear connection. It should only be used in conjunction with ductile shear connectors, such as tie-bar shear connector.
- (2) One of the two tie-bars of each connector failed in shear, due to the direct contact with the movement of the web. It is recommended that tie-bar should be placed closer to the centre of the web opening, thus preventing shear failure of the bar.
- (3) Failure of the ducting occurred when the shear connector reached relatively low load levels. It is recommended that ducting shear connectors are used only in the low shear regions. If they are to be used in high shear regions, suitable web stiffeners should be added in that region to redistribute the shear flow.

9. References

- [1] HICKS S., "Current Trend in Modern Floor Construction", *The Steel Construction Institute*, Vol. 11, No. 1, 2003, pp. 32-32.
- [2] TSAVDARIDIS K.D., D'MELLO C., and HUO B.Y., "Computational Study Modelling the Experimental Work Conducted on the Shear Capacity of Perforated Concrete-Steel Ultra Shallow Floor Beams (USFB)", *Proceedings of 16th Hellenic Concrete Conference*, Paphos, Cyprus, 2009, pp. 159.
- [3] Westok Limited UK, "<http://www.westok.co.uk/Applications/Ultra%20Shallow>".
- [4] Eurocode 4, EN 1994-1-1:2004, "Eurocode 4: Design of Composite Steel and Concrete Structures, Part 1-1: General Rules and Rules for Buildings".