



Deposited via The University of Leeds.

White Rose Research Online URL for this paper:

<https://eprints.whiterose.ac.uk/id/eprint/80310/>

Version: Accepted Version

Article:

Lane, RW, Menon, M, McQuaid, JB et al. (2013) Laboratory analysis of the effects of elevated atmospheric carbon dioxide on respiration in biological soil crusts. *Journal of Arid Environments*, 98. 52 - 59. ISSN: 0140-1963

<https://doi.org/10.1016/j.jaridenv.2013.07.014>

Reuse

Items deposited in White Rose Research Online are protected by copyright, with all rights reserved unless indicated otherwise. They may be downloaded and/or printed for private study, or other acts as permitted by national copyright laws. The publisher or other rights holders may allow further reproduction and re-use of the full text version. This is indicated by the licence information on the White Rose Research Online record for the item.

Takedown

If you consider content in White Rose Research Online to be in breach of UK law, please notify us by emailing eprints@whiterose.ac.uk including the URL of the record and the reason for the withdrawal request.

1 Laboratory Analysis of Elevated Atmospheric Carbon Dioxide on Carbon Fluxes for
2
3 Cyanobacterial Biological Soil Crusts
4

5 Richard W Lane^{1*}, Manoj Menon^{1*}, James B McQuaid^{§1}, David G Adams², Andrew
6
7 D Thomas^{3*}, Steve R Hoon³ and Andrew J Dougill¹
8
9

10
11 ¹School of Earth and Environment, University of Leeds, Leeds, LS2 9JT, UK
12

13
14 ²Institute of Integrative and Comparative Biology, Faculty of Biological Sciences,
15
16 University of Leeds, Leeds, LS2 9JT, UK
17

18
19 ³School of Science and the Environment, Manchester Metropolitan University,
20
21 Manchester, M1 5GD, UK
22

23
24 [§]Corresponding author; Address: ¹School of Earth and Environment (Dr. Jim
25
26 McQuaid), University of Leeds, Leeds, LS2 9JT, UK; Email:
27
28 J.B.McQuaid@leeds.ac.uk
29

30
31
32
33 Phone: +44 (0) 113 343 6724; Fax: +44 (0) 113 343 5259
34
35

36
37
38
39 *Current address
40

41
42 Manoj Menon: KROTO Research Institute, Department of Civil and Structural
43
44 Engineering, University of Sheffield (North Campus), Sheffield, S37HQ, UK;
45

46
47 Andrew D Thomas: Institute of Geography and Earth Sciences, Aberystwyth
48
49 University, Penglais Campus, Aberystwyth, SY23 3DB, UK
50

51
52
53
54
55 *Keywords: biological soil crust, cyanobacteria, photosynthesis, respiration, drylands,*
56
57 *Kalahari, soil carbon sequestration, heterotrophic, autotrophic, CO₂ flux double*
58
59 *CO₂,*
60

Abstract

1
2
3 Metabolic activity of Biological Soil Crusts (BSCs) is principally dependent on
4
5 moisture availability, but also on temperature and light conditions. Less understood is
6
7 how BSCs respond to elevated atmospheric CO₂. This paper reports laboratory
8
9 experimental results of elevated atmospheric CO₂ on carbon fluxes for cyanobacterial
10
11 BSCs. The study uses newly designed dynamic gas exchange chambers in which the
12
13 internal atmosphere was controlled. CO₂ flux was monitored during controlled
14
15 experiments in two phases under simulated rainfall events (2 & 5 mm plus control
16
17 with no wetting) each lasting 3 days with a dry period in between. Phase 1 subjected
18
19 crusts to 392 ppm CO₂ (representing ambient level) in dry air; in phase 2, the CO₂
20
21 concentration was 801 ppm. Both phases exhibited significant efflux (respiration) of
22
23 CO₂ immediately after wetting, followed by substantial influx (sequestration) of CO₂.
24
25 Samples subject to 2 mm wetting sequestered an order of magnitude more C under
26
27 elevated CO₂ than at ambient CO₂; for samples subject to 5 mm wetting, this increase
28
29 was threefold. The findings highlight the role of BSCs in future carbon budgets by
30
31 enabling greater sequestration into dryland soils even under enhanced atmospheric
32
33 CO₂ concentrations, following both light and heavy rainfall events.
34
35
36
37
38
39
40
41
42
43
44
45
46
47
48
49
50
51
52
53
54
55
56
57
58
59
60
61
62
63
64
65

1. Introduction

Dryland soils cover approximately 41% of the Earth's terrestrial surface and support more than one-third of the global population (Reynolds et al., 2007). Recent findings suggest that sub-Saharan Africa has acted as a likely net carbon sink within the last decade (Ciais et al., 2009) with a net balance of approximately 0.97 Pg C y^{-1} uptake (Bombelli et al., 2009). However, the role of soils and their Biological Soil Crust (BSC) cover remains only sparsely assessed (see reviews by Maestre et al., 2012 a,b; Stringer et al., 2012) but with BSCs identified as a major contributor to overall CO_2 efflux in drylands (e.g. Castillo-Monroy et al., 2011).

BSCs are made of cyanobacteria and other bacterial species, algae, lichens, mosses and microfungi. In general, BSCs cover up to 70 % (Belnap and Lange, 2003) of the soil surface of many drylands and in some undisturbed areas such as in Wildlife Management Areas of the Kalahari BSCs cover more than 90% of the soil surface (Dougill and Thomas, 2004). Globally, cyanobacterial biomass in dryland areas is estimated to be 56 Pg of carbon (Garcia-Pichel et al., 2003), therefore constituting a significant part of the estimated 241 Pg of soil organic carbon (SOC) contained within drylands (Lal, 2004). The estimated total global Carbon net uptake of BSCs has been approximated as 3.9 Pg yr^{-1} (corresponding to approximately 7% of global net primary production uptake) (Elbert et al., 2012) but the controls on rates of CO_2 efflux remain poorly understood (Frey et al., 2013).

Substantial amounts of carbon are also being lost from BSCs via respiration (Huxman et al., 2004; Thomas et al., 2008; Thomas and Hoon, 2010; Thomas et al., 2011) particularly after rainfall events; due to activity and substrate availability increases within microbial populations (Borken and Matzner, 2009). During hours when moisture, temperature and light availability are optimum gain of carbon

1 (photosynthesis) occurs; prior to these optimum conditions (particularly in the
2 absence of light) an initial efflux is observed (Evans and Johansen, 1999; Thomas et
3 al., 2011; Thomas, 2012).
4
5

6
7 Free Air Carbon Enrichment (FACE) facilities have been set up in several
8 dryland study sites to investigate the effects of increasing atmospheric CO₂ on
9 vascular vegetation and soils (e.g. de Soyza et al., 2005; Steven et al., 2012). For
10 example, ten years of FACE field studies in Nevada suggest that enhanced CO₂
11 treatments cyanobacteria will show a generalized decline with elevated CO₂ though
12 the direct impacts on CO₂ efflux rates remains unknown (Steven et al., 2012). . A
13 similar experiment in the Mojave desert conveys the importance of BSCs in the
14 uptake of CO₂; whereby in post rain conditions the net ecosystem CO₂ exchange
15 (uptake) was unexpectedly high and was likely due to autotrophic mechanisms as
16 vascular plant photosynthesis was low at this time (Jasoni et al., 2005).
17
18
19
20
21
22
23
24
25
26
27
28
29
30
31

32 The aim of this experimental study was to quantify the short-term temporal
33 changes in carbon exchange (respiration and photosynthesis) of BSCs when the
34 atmospheric concentration of CO₂ was doubled (~800 ppm). The study was conducted
35 using specially designed dynamic gas exchange chambers (DGECs) and
36 cyanobacteria-dominated BSCs sampled from Kalahari Sand soils of southern Africa,
37 a large dryland biome which covers 2.5 million hectares (Wang et al., 2007). In
38 addition to the doubled CO₂ atmospheric level in laboratory studies, two wetting
39 treatments (2 and 5 mm) were incorporated. This also added an extra dimension and
40 additional data on BSCs responses to key conditions of both soil moisture and
41 atmospheric CO₂ concentration.
42
43
44
45
46
47
48
49
50
51
52
53
54
55
56
57
58
59

60 **2. Methods**

61
62
63
64
65

2.1 Culturing BSCs in Controlled Conditions

Both crusts and subsoil samples were collected from a lightly grazed commercially-owned farm near Tsabong, Botswana (25°56'51"S 22°25'40"E) during a field campaign in summer 2008. The subsoil (97% fine sand, pH 5.9 ± 0.4 , bulk density $1.85 \pm 0.03 \text{ g cm}^3$ and porosity $0.34 \pm 0.01 \text{ v/v}$) (Thomas and Hoon, 2010) was sieved (853 μm), sterilized (autoclaved at 121 °C for 15 min) and then filled (178 g each) in nine polyethylene terephthalate (PET) containers (diameter = 93 mm and depth = 25 mm). Soil depth was approximately 20 mm, a depth such that a 5 mm wetting would result in near saturation. On the soil surface, biological soil crust samples were gently broken into similarly sized pieces and distributed evenly and equally (3.32 g per container) in all PET containers. Samples were weighed again and then wetted using 10 ml of pure water (purity > 99%) applied using a calibrated water sprayer. This initial wetting consolidated the soil and the samples were left in an environmental cabinet (the conditions of which are outlined below) to settle into a circadian rhythm. The samples were allowed to establish for two months in a growth cabinet and the crust surfaces were gently moistened several times a week (1-5 mm each), a total of 53.2 mm (361 ml) of water per container. Included in several of these treatments was the addition of standard nutrient medium, BG11 (Rippka et al., 1979), which was diluted with water, to encourage growth of the cyanobacteria.

The growth cabinet was set to provide 16 hours of light (intensity = $76 \pm 1 \mu\text{mol m}^{-2} \text{ s}^{-1}$, measured as an average at the central position of each cabinet shelf) and a temperature of $28 \pm 0.3 \text{ }^\circ\text{C}$; the remaining 8 hours with no light at a temperature of $10 \pm 0.3 \text{ }^\circ\text{C}$. The light intensity in the cabinet represented early morning hours during austral winter in the Kalahari where maximum microbial activity occurs (Evans and Johansen, 1999; Thomas and Hoon, 2010). Four USB loggers (USB-500

1 Measurement Computing Corporation) were placed in various positions within the
2 cabinet, in order to record internal temperature, which ranged from 7.5-30.5°C in
3
4 phase 1 and 7.5-29.0°C in phase 2. Relative humidity was not recorded because the
5
6 sensors were located within the environmental cabinet and not in the enclosed and
7
8 therefore isolated (to external relative humidity) design of the DGECs.
9
10

11 **2.2 Dynamic Gas Exchange Chambers (DGECs)**

12
13
14 The design of the chambers used was developed from that proposed and used
15
16 successfully in field conditions by Hoon et al. (2009). Chambers were designed to
17
18 house the PET containers containing crust samples. Chambers were made using
19
20 transparent Perspex® material (3 mm thickness) with a height of 103 mm and 100
21
22 mm outer diameter, allowing 92% transmission of PAR (400 nm-700 nm),
23
24 transmission of thermal infrared (IR) and filtered ultraviolet radiation (UV) < 300 nm;
25
26 the top of the chamber was fitted with a removable cap made of Teflon® film that
27
28 allowed 96% transmission of incoming radiation (Figure 1). The Teflon® film was
29
30 able to accommodate pressure changes within the chambers by acting as a diaphragm.
31
32 Each chamber was made air-tight and had ports (Suba-Seals®) from which samples
33
34 were collected at regular intervals. Chambers were attached (via the gas inlets) to the
35
36 main vessel of 32 l volume, containing the CO₂-air mix. Open-cell foam inserts were
37
38 placed into the gas inlets and outlets in order to prevent diffusion of atmospheric
39
40 gases into or out of the chamber, while permitting the flushing of the chamber and
41
42 equilibration with the external atmospheric pressure, should it become over
43
44 pressurized. A Teflon® bag was attached to the end of the flush-gas feed line in order
45
46 to confirm flow of the flush gas. Final checks were made for any leaks. After this,
47
48
49
50
51
52
53
54
55
56
57
58
59
60
61
62
63
64
65
66
67
68
69
70
71
72
73
74
75
76
77
78
79
80
81
82
83
84
85
86
87
88
89
90
91
92
93
94
95
96
97
98
99
100
101
102
103
104
105
106
107
108
109
110
111
112
113
114
115
116
117
118
119
120
121
122
123
124
125
126
127
128
129
130
131
132
133
134
135
136
137
138
139
140
141
142
143
144
145
146
147
148
149
150
151
152
153
154
155
156
157
158
159
160
161
162
163
164
165
166
167
168
169
170
171
172
173
174
175
176
177
178
179
180
181
182
183
184
185
186
187
188
189
190
191
192
193
194
195
196
197
198
199
200
201
202
203
204
205
206
207
208
209
210
211
212
213
214
215
216
217
218
219
220
221
222
223
224
225
226
227
228
229
230
231
232
233
234
235
236
237
238
239
240
241
242
243
244
245
246
247
248
249
250
251
252
253
254
255
256
257
258
259
260
261
262
263
264
265
266
267
268
269
270
271
272
273
274
275
276
277
278
279
280
281
282
283
284
285
286
287
288
289
290
291
292
293
294
295
296
297
298
299
300
301
302
303
304
305
306
307
308
309
310
311
312
313
314
315
316
317
318
319
320
321
322
323
324
325
326
327
328
329
330
331
332
333
334
335
336
337
338
339
340
341
342
343
344
345
346
347
348
349
350
351
352
353
354
355
356
357
358
359
360
361
362
363
364
365
366
367
368
369
370
371
372
373
374
375
376
377
378
379
380
381
382
383
384
385
386
387
388
389
390
391
392
393
394
395
396
397
398
399
400
401
402
403
404
405
406
407
408
409
410
411
412
413
414
415
416
417
418
419
420
421
422
423
424
425
426
427
428
429
430
431
432
433
434
435
436
437
438
439
440
441
442
443
444
445
446
447
448
449
450
451
452
453
454
455
456
457
458
459
460
461
462
463
464
465
466
467
468
469
470
471
472
473
474
475
476
477
478
479
480
481
482
483
484
485
486
487
488
489
490
491
492
493
494
495
496
497
498
499
500
501
502
503
504
505
506
507
508
509
510
511
512
513
514
515
516
517
518
519
520
521
522
523
524
525
526
527
528
529
530
531
532
533
534
535
536
537
538
539
540
541
542
543
544
545
546
547
548
549
550
551
552
553
554
555
556
557
558
559
560
561
562
563
564
565
566
567
568
569
570
571
572
573
574
575
576
577
578
579
580
581
582
583
584
585
586
587
588
589
590
591
592
593
594
595
596
597
598
599
600
601
602
603
604
605
606
607
608
609
610
611
612
613
614
615
616
617
618
619
620
621
622
623
624
625
626
627
628
629
630
631
632
633
634
635
636
637
638
639
640
641
642
643
644
645
646
647
648
649
650
651
652
653
654
655
656
657
658
659
660
661
662
663
664
665
666
667
668
669
670
671
672
673
674
675
676
677
678
679
680
681
682
683
684
685
686
687
688
689
690
691
692
693
694
695
696
697
698
699
700
701
702
703
704
705
706
707
708
709
710
711
712
713
714
715
716
717
718
719
720
721
722
723
724
725
726
727
728
729
730
731
732
733
734
735
736
737
738
739
740
741
742
743
744
745
746
747
748
749
750
751
752
753
754
755
756
757
758
759
760
761
762
763
764
765
766
767
768
769
770
771
772
773
774
775
776
777
778
779
780
781
782
783
784
785
786
787
788
789
790
791
792
793
794
795
796
797
798
799
800
801
802
803
804
805
806
807
808
809
810
811
812
813
814
815
816
817
818
819
820
821
822
823
824
825
826
827
828
829
830
831
832
833
834
835
836
837
838
839
840
841
842
843
844
845
846
847
848
849
850
851
852
853
854
855
856
857
858
859
860
861
862
863
864
865
866
867
868
869
870
871
872
873
874
875
876
877
878
879
880
881
882
883
884
885
886
887
888
889
890
891
892
893
894
895
896
897
898
899
900
901
902
903
904
905
906
907
908
909
910
911
912
913
914
915
916
917
918
919
920
921
922
923
924
925
926
927
928
929
930
931
932
933
934
935
936
937
938
939
940
941
942
943
944
945
946
947
948
949
950
951
952
953
954
955
956
957
958
959
960
961
962
963
964
965
966
967
968
969
970
971
972
973
974
975
976
977
978
979
980
981
982
983
984
985
986
987
988
989
990
991
992
993
994
995
996
997
998
999
1000

1 inside the growth cabinet. Care was taken to minimize the disturbance to the crust
2 samples. The final set up is given in Figure 2.
3
4
5
6

7 **2.3 Treatments and Sampling Regime**

8

9 Experiments were conducted in two phases (3 days each, as during the preliminary
10 run, mentioned below, the behavior had stabilized by the end of day three) to study
11 the impacts of elevated CO₂ along with different wetting treatments. Phase 1 was
12 carried out under ambient CO₂ level (392 ppm in air, with a standard deviation of 4.4
13 ppm, blended in-laboratory from pure dry air and 1003 ppm CO₂-air mix blended by
14 Air Liquide) with three single wetting treatments (0, 2 and 5 mm) with three
15 replicates. After phase 1, covers were removed and water added to the 0 and 2 mm
16 treatments (5 and 3 mm water, respectively) in order to equalize the moisture content
17 with the 5 mm wetting treatments. Covers were left off and the crusts allowed to dry
18 out again. They reached the initial moisture content 4-5 days after this and were then
19 moistened once a week before commencement of phase 2 (phase 2 was undertaken
20 three months after phase 1). Phase two was undertaken using the same method as
21 phase 1, on the same crust samples, this time with elevated CO₂ (801 ppm in air,
22 blended by Air Liquide).
23
24
25
26
27
28
29
30
31
32
33
34
35
36
37
38
39
40
41
42
43

44 Approximately 12 hours prior to experiments, the CO₂-air mix was used to
45 flush the chambers. This was in order to allow diffusion through the air spaces in the
46 soil, such that the concentration gradient between subsoil and atmosphere was
47 reduced and to acclimatize the crust to the new environment. The first gas sample was
48 taken (0815 GMT) the following morning, two hours before lights on (1015 GMT).
49 Samples were then weighed and the Teflon® lids opened for wetting (simulating a
50 single rainfall event of 2 or 5 mm) using a Jencons Powerpette for even application.
51
52
53
54
55
56
57
58
59
60
61
62
63
64
65

1 The chambers were immediately weighed and closed; then placed back into the
2 growth cabinet and re-attached to the gas line. All chambers were again flushed with
3 the CO₂-air mix. Chambers were then left for approximately 40 min before gas
4 samples were taken, followed by flushing; with the exception of the last flush of each
5 day which was left overnight and the gas sample taken immediately the following
6 morning. Each flushing was 12 min (this was determined during initial DGEC design
7 testing in the laboratory). Chamber venting time was close to optimum (40 min),
8 which has been determined by a sensitivity analysis of static gas chambers on soils
9 (Ohlsson et al., 2005), in which it was concluded that it is possible to reduce the
10 uncertainty in the CO₂ flux value by allowing extended CO₂ accumulation/reduction
11 times. Nine gas samples (10 ml each) were collected per chamber at regular intervals
12 during the day (0815-1715 GMT with at least two samples taken before lights on) for
13 three days and a total of 243 samples were collected from each phase of this
14 experiment. A preliminary run (with 410 ppm CO₂-air mix) was carried out prior to
15 the experiment reported here to check the system.

16
17 Sample weights were taken only at the beginning and end of each phase in
18 order to quantify moisture loss. Moisture loss during the experiment was found to be
19 negligible in the DGECs, due to the chambers being closed.

20 21 22 **2.4 Analysis of CO₂ Using Gas Chromatography with Helium Ionization**

23 24 25 **Detection**

26
27 Temporal changes in CO₂ concentration within the DGECs reflect the activity
28 (photosynthesis and respiration) of biological soil crusts. To measure the changes in
29 CO₂ levels, 2.5 µl gas samples were taken at approximately 40 minute intervals
30 throughout the experiment and were separated using a Porous Layer Open Tubular
31
32
33
34
35
36
37
38
39
40
41
42
43
44
45
46
47
48
49
50
51
52
53
54
55
56
57
58
59
60
61
62
63
64
65

1 (PLOT) column (PoraPLOT Q, 25 m x 0.53 mm, 20 µm i.d. Chrompack,
2 Netherlands). A helium ionization detector (VICI, Houston, USA) was used to
3
4 quantify the eluate. The dimensionless integrals of the CO₂ peaks were converted to
5
6 ppm and then to carbon flux in mg C m⁻² hr⁻¹ using Equation 1;
7
8
9

$$10 \text{ C Flux Rate} = \{([\text{CO}_2]_{\text{diff}} \times n) / (A \times t)\} \times V_s \times M_C \times 3,600 \text{ mg C m}^{-2} \text{ hr}^{-1} \quad (1)$$

11
12
13
14
15
16
17 where $[\text{CO}_2]_{\text{diff}}$ = difference between measured CO₂ concentration and flush CO₂
18
19 concentration in ppm; n = number of moles of gas present in loop at temperature T
20
21 (°C);

22
23
24 A = surface area of soil sample ($6.793 \times 10^{-3} \text{ m}^2$); t = time between end of last flush and
25
26 taking of gas sample (s); V_s = volumetric scaling factor = 222,072; M_C = molar mass
27
28 of carbon ($12.0107 \text{ g mol}^{-1}$) and 3,600 is used to represent flux over one hour.

29
30
31 Net carbon balances were based on the area under each carbon flux time series and
32
33 were calculated separately for each chamber for each day using the integral function
34
35 in EasyPlot™ software. In order to characterize significance of treatments (two levels
36
37 of CO₂ and three levels of wetting), analysis of variance (ANOVA) was undertaken
38
39 using statistical package SYSTAT 13 which determines the p-value for CO₂, wetting
40
41 and also whether or not these values are statistically significant.
42
43
44
45
46
47
48
49
50
51
52
53
54
55

56 **3. Results**

57 **3.1 Carbon fluxes in absence of liquid water (controls)**

58
59
60
61
62
63
64
65

1 Temporal changes in CO₂ concentrations in the chambers were measured to
2 understand the short-term responses to elevated CO₂ levels along with pulse wetting
3 events. The positive values of flux in Figures 3 – 5 indicate net respiration and
4 negative values indicate net photosynthesis. Net carbon balances for each individual
5 chamber, on each day of both phases can be seen in Tables 1 & 2.
6
7
8
9
10

11
12 Figures 3a and 3b show temporal changes in the fluxes in the dry chambers
13 (controls) for phase 1 (392 ppm CO₂) and phase 2 (801 ppm CO₂), respectively. The
14 activity of the crust was very low due to there being no liquid moisture available. For
15 phase 1, the carbon loss (net respiration) dominated over the gain of carbon (net
16 photosynthesis) whereas for phase 2, the opposite was found. Tables 1 & 2 show that,
17 interestingly, many of the replicates exhibited appreciable carbon fixation even when
18 no liquid moisture was available (with the exception of air moisture). However, the
19 net carbon budgets over three days showed that, 0.02 ± 0.01 mg C was lost in phase 1
20 and 0.39 ± 0.04 mg C was sequestered for phase 2.
21
22
23
24
25
26
27
28
29
30
31
32
33
34
35

36 **3.2 Carbon fluxes under 2 mm wetting treatment**

37
38
39 Figures 4a & 4b display the carbon release during the first day from the samples soon
40 after the wetting treatment for both phases. The samples continued respiration for the
41 majority of the first day and settled into a photosynthetic regime by the end of the day.
42
43
44
45
46 The second and third days show the samples to be predominantly photosynthetic in
47 activity. This photosynthetic activity peaked toward the end of each day. The quantity
48 of liquid moisture available for the samples for each of the three days, remained
49 largely unchanged. Tables 1 & 2 show the net carbon balances (in mg) of all
50
51
52
53
54
55
56
57
58
59
60
61
62
63
64
65 chambers for each day of each phase. After a 2 mm wetting treatment and subject to
the conditions of phase 1 the crust sequestered a total of 0.14 ± 0.14 mg C and during

1 phase 2 this was 1.3 ± 0.5 mg C. All cell group averages displayed net sequestration
2 for both phases under 2 mm wetting, with phase 2 showing the highest quantity of
3 carbon sequestered.
4
5
6
7
8

9 **3.3 Carbon fluxes under 5 mm wetting treatment**

10 When the 5 mm wetting treatment was applied the wetting front reached the bottom of
11 each container, therefore saturating the soil. Moisture remained available for the
12 samples for each of the three days, and the quantity remained largely unchanged.
13
14 Figures 5a & 5b display the carbon fluxes of the chambers subject to a 5 mm wetting
15 treatment for each phase. It can be seen that throughout each experiment, a pulse of
16 carbon was released at the beginning of each day, particularly during phase 1,
17 indicating respiration. The samples exhibited very similar behavior to those subject to
18 2 mm wetting; the main difference being a moderate carbon pulse at the beginning of
19 each day and overall larger fluxes. For phase 2, the carbon losses were found to be
20 similar to phase 1; however the peak influx (sequestration) was 2-3 times larger than
21 phase 1. Tables 1 & 2 show the net carbon balances (in mg) of all chambers for each
22 day of each phase. After a 5 mm wetting treatment and subject to the conditions of
23 phase 1, 0.62 ± 0.05 mg C was sequestered and during phase 2, 2 ± 0.2 mg C was
24 sequestered. Phase 2 showed the highest quantity of carbon sequestered.
25
26
27
28
29
30
31
32
33
34
35
36
37
38
39
40
41
42
43
44
45

46 ANOVA significance testing of daily carbon sequestration (i.e. all negative
47 values from Tables 1 & 2) was undertaken. Tables 1 & 2 show the highly significant
48 effects of CO₂ (P value = 0.005) and wetting (P value = 0.001), however the
49 interaction between these factors was not found to be significant.
50
51
52
53
54
55
56
57
58
59
60
61
62
63
64
65

4. Discussion

All carbon balances, with the exception of the dry samples at 392 ppm CO₂, were negative. This suggests that the overall, the dominant process was photosynthesis. This shows that isolation of the autotrophs has been achieved, although it should be noted that BSCs colonies are an amalgamation of heterotrophs and autotrophs, and as such there is potential for both photosynthesis and respiration to occur simultaneously. This is further confirmed when considering the pulse CO₂ efflux effects observed in those samples subject to wetting treatments, although interestingly initial pulses were lower under 801 ppm CO₂ than under 392 ppm CO₂ perhaps suggesting that the CO₂ concentrating mechanism (CCM) (Badger and Price, 1992) activity was enhanced under the increased CO₂ atmosphere. Respiration was observed early each day in the samples subjected to wetting treatments due to the absence of light (and in some cases lasted for a short duration after the lights were on); again these effluxes were lower under higher ambient CO₂ levels.

Overall, each of the wetting treatments yielded higher influx of carbon when subject to an 801 ppm CO₂-air mix than when subject to the 392 ppm CO₂-air mix. Of these the most significant were the samples subjected to a 2 mm wetting treatment; carbon influx increased by an order of magnitude suggesting that photosynthetic activity in the BSCs samples responded best to 'light' wetting treatments/events. Increases in carbon influx of three fold were observed in those samples with a 5 mm wetting treatment, still representing a significant relative increase in carbon influx under increased atmospheric CO₂. Samples which had no additional water added also exhibited increased carbon influx under enhanced atmospheric CO₂; this is very likely due to moisture formation in the form of condensation on the soil surface during the

1
2
3
4
5
6
7
8
9
10
11
12
13
14
15
16
17
18
19
20
21
22
23
24
25
26
27
28
29
30
31
32
33
34
35
36
37
38
39
40
41
42
43
44
45
46
47
48
49
50
51
52
53
54
55
56
57
58
59
60
61
62
63
64
65

‘night-time’ part of the cycle creating a source of liquid moisture for the BSCs, facilitating photosynthesis.

The finding that the relative increase in carbon influx was highest in the 2 mm wetting treatment is complementary to the field-based findings of Thomas et al. (2008) whereby not only do the autotrophs respond best to ‘light’ wetting treatments, but the light wetting also limits the depth of soil which receives moisture, hence reducing the effect that subsoil heterotrophs have on the net carbon balance. Light rainfall events are common across the Kalahari, particularly at the beginning of the wet season and have an important effect upon the annual soil carbon balance (Thomas et al., 2011). The results presented here are promising for the continuing role of BSCs as a carbon store as atmospheric CO₂ increases, provided rainfall patterns remain at higher frequencies of light events as currently seen (Simelton et al., 2013) rather than moving to more extreme intense rainfall events as predicted by some for dryland Africa more widely (e.g. Twomlow et al., 2008)).

Although the mechanisms of increased carbon sequestration were not investigated in this study, Badger and Price (1992) describe the CO₂ concentrating mechanisms of cyanobacteria, which are capable of concentrating CO₂ up to 1000-fold. The cyanobacterial CO₂ concentrating mechanism is possibly the most effective of any photosynthetic organism (Badger and Price, 1992), and therefore it would be hoped that this effect would be amplified if elevated levels of CO₂ were made available (up until saturation). Cyanobacterial species are among the earliest forms of life, having evolved under, and been exposed to, the high CO₂/low O₂ atmosphere of the early (~3,000 Ma) Earth (Bowes, 1991); therefore it could be postulated that cyanobacterial photosynthetic activity is optimum when exposed to the conditions under which the organisms evolved, and hence a positive correlation between

1 photosynthetic activity and increasing CO₂ levels may exist. The findings of this study
2 appear consistent with this hypothesis; however the exact mechanisms require further
3 investigation. Further evidence is the ability of CO₂ concentrating mechanism to
4 modulate activity under the influence of environmental factors; cyanobacteria (and
5 other CO₂ concentrating mechanisms) can acclimate to a wide range of CO₂
6 concentrations (as also show in FACE studies of Steven et al., 2012).
7
8
9
10
11
12
13

14 This study demonstrated the carbon sequestration potential of BSCs under
15 elevated CO₂ levels under two moisture regimes. The response was similar to many
16 crops (Cure and Acock, 1986) and dryland vegetation (Naumburg et al., 2003) under
17 elevated levels of CO₂ in the atmosphere. BSCs have the potential to fix carbon under
18 limited soil moisture availability and nutrient poor soils (typical of drylands) and is
19 especially applicable to BSCs dominated by nitrogen fixing cyanobacteria. Therefore
20 undisturbed BSC-covered drylands could be enhanced carbon sinks, and play an
21 increasingly significant role in global carbon budgets in years to come. With this in
22 mind, protection of BSCs is of increasing importance, particularly considering land
23 use pressures on these areas (Dougill and Thomas, 2004), where implementation of
24 community-based ecosystem service schemes such as those described by Dougill et
25 al. (2012) could be greatly beneficial to dryland areas. More long-term flux
26 monitoring studies are required with varying environmental conditions, particularly
27 concerning BSCS responses to increased temperatures (e.g. Frey et al., 2013) and
28 incoming solar radiation with varying wetting treatments.
29
30
31
32
33
34
35
36
37
38
39
40
41
42
43
44
45
46
47
48
49
50
51
52
53
54

55 **Acknowledgements**

56
57
58
59
60
61
62
63
64
65

1 The author would like to extend much gratitude to Mr. Lance Penketh of the
2 University of Leeds during the course of incubation and experimentation using the
3 growth cabinets. The author is grateful for the funding provided by the Natural
4 Environment Research Council (NERC) Taught Postgraduate Fund, with which this
5 research work was carried out.
6
7
8
9
10
11
12
13
14
15
16
17
18
19
20
21
22
23
24
25
26
27
28
29
30
31
32
33
34
35
36
37
38
39
40
41
42
43
44
45
46
47
48
49
50
51
52
53
54
55
56
57

58 **References**

59
60
61
62
63
64
65

1 Badger, M., Price, G., 1992. CO₂ concentrating mechanisms in cyanobacteria:
2 molecular components, their diversity and evolution. *J. Exp. Botany*. 54, 609-622.

3 Belnap, J., Kaltenecker, J., Rosentreter, R., Williams, J., Leonard, S., Eldridge, D.,
4 2001. Introduction to Biological Soil Crusts. *Biological Soil Crusts: Ecology and*
5 *Management, Technical Reference*. Denver: United States Department of the Interior,
6 pp. 1-7.

7
8
9 Belnap, J., Lange, O., 2003. Preface. In: Belnap J & Lange OL (Eds.), *Biological Soil*
10 *Crusts: Structure, Function, and Management*. Berlin: Springer-Verlag, pp. V-IX.

11
12 Beymer, R., Klopatek, J., 1991. Potential contribution of carbon by microphytic crusts
13 in pinyon-juniper woodlands. *Arid Soil Research and Rehabilitation*. 5, 187-198.

14
15
16 Bombelli, A., Henry, M., Castaldi, S., Adu-Bredu, S., Arneith, A., de Grandcourt, A.,
17 Grieco, E., Kutsch, W., Lehsten, V., Rasile, A., Reichstein, M., Tansey, K., Weber,
18 U., Valentini, R., 2009. An outlook on the Sub-Saharan Africa carbon balance.
19 *Biogeosci.* 6, 2193-2205.

20
21
22 Borken, W., Matzner, E., 2009. Reappraisal of drying and wetting effects on C and N
23 mineralisation and fluxes in soils. *Global Change Biol.* 15, 808-824.

24
25
26 Bowes, G., 1991. Growth at elevated CO₂: photosynthetic responses mediated through
27 Rubisco. *Plant, Cell and Env.* 14, 795-806.

28
29 Brostoff, W., Sharifi, M., Rundel, P., 2001, Photosynthesis of cryptobiotic crusts in a
30 seasonally inundated system of pans and dunes at Edwards Air Force Base, western
31 Mojave Desert, California: Laboratory studies, *Flora*, 197, 143-151.

32
33
34 Büdel, B., Darienko, T., Deutschewitz, K., Dojani, S., Friedl, T., Kohr, K., Salisch,
35 M., Reisser, W., Weber, B., 2009. Southern African biological soil crusts are
36 ubiquitous and highly diverse in drylands, being restricted by rainfall frequency.
37 *Microb. Ecol.* 57, 229-247.

38
39
40 Cable, J., Huxman, T., 2004. Precipitation pulse size effects on Sonoran Desert soil
41 microbial crusts. *Oecologia*. 141, 317-324.

42
43 Castillo-Monroy A.P, Maestre F.T, Rey A., Soliveres S., García-Palacios P. (2011)
44 Biological soil crust microsites are the main contributor to soil respiration in a
45 semiarid ecosystem. *Ecosystems*, 14, 835-847.

46
47
48 Ciais, P., Piao, S.-L., Cadule, P., Friedlingstein, P., Chéduin, A., 2009. Variability and
49 recent trends in the African terrestrial carbon balance. *Biogeosci.* 6, 1935-1948.

50
51
52 Cure, J., Acock, B., 1986. Crop Responses to Carbon Dioxide Doubling: A Literature
53 Survey. *Agric. and Forest Meteo.* 38, 127-145.

54
55 de Soyza, A., Nowak, R., Knight, E., Babcock, D., Smith-Longozo, V., 2005. Effects
56 of elevated atmospheric CO₂ on soil respiration in a Mojave Desert ecosystem.
57
58
59
60
61
62
63
64
65

1 Dougill, A.J., Stringer, L.C., Leventon, J., Riddell, M., Rueff, H., Spracklen, D., Butt,
2 E., 2012. Lessons from community-based payment for ecosystem service schemes:
3 from forests to rangelands. *Phil. Trans. Royal Soc. Biol. Sci.* 367, 3178-3190.

4 Dougill, A.J., Thomas, A.D., 2004. Kalahari Sand Soils: Spatial Heterogeneity,
5 Biological Soil Crusts and Land Degradation. *Land Deg. & Devel.* 15, 233-242.

6
7
8 Elbert, W., Weber, B., Burrows, S., Steinkamp, J., Büdel, B., Andreae, M., Pöschl, U.,
9 2012. Contribution of cryptogamic covers to the global cycles of carbon and nitrogen.
10 *Nat. Geosci.* 5, 459-462.

11
12
13 Evans, R., Johansen, J., 1999. Microbiotic Crusts and Ecosystem Processes. *Crit. Rev.*
14 *Plant Sci.* 18, 183-225.

15
16 Frey, S.D., Lee, J., Melillo, J.M., Six, J., 2013. The temperature response of soil
17 microbial efficiency and its feedback to climate. *Nature Climate Change.* 3, 395-398.

18
19
20 Garcia-Pichel, F., Belnap, J., Neuer, S., Schanz, F., 2003. Estimates of global
21 cyanobacterial biomass and its distribution. *Algological Stud.* 109, 213-227.

22
23 Hoon, S., Thomas, A.D., Linton, P., 2009. The Design and Development of a Closed
24 Chamber for the in-situ Quantification of Dryland Soil Carbon Dioxide Fluxes. *Geog.*
25 *Res.* 47, 71-82.

26
27
28 Huxman, T., Snyder, K., Tissue, D., Leffler, A., Ogle, K., Pockman, W., Sandquist,
29 D., Potts, D., Scwinning, S., 2004. Precipitation pulses and carbon fluxes in semiarid
30 and arid ecosystems. *Oecologia.* 141, 254-268.

31
32 Jasoni, R., Smith, S. Arnone III, J., 2005. Net ecosystem CO₂ exchange in Mojave
33 Desert shrublands during the eighth year of exposure to elevated CO₂. *Global Change*
34 *Biol.* 11, 749-756.

35
36
37 Jeffries, D., Link, S., Klopatek, J., 1993. CO₂ fluxes of cryptogamic crusts. *New*
38 *Phytol.* 125, 163-173.

39
40
41 Kaplan, A., Reinhold, L., 1999. CO₂ Concentrating Mechanisms in Photosynthetic
42 Microorganisms. *Ann. Rev. Plant Phys. and Plant Mol. Biol.* 50, 539-570.

43
44 Lal, R., 2004. Carbon Sequestration in Dryland Ecosystems. *Env. Man.* 33, 528-544.

45
46
47 Lange, O., 2003. Photosynthesis of Soil-Crust Biota as Dependent on Environmental
48 Factors. In: Belnap, J. & Lange, O. (Eds.), *Biological Soil Crusts: Structure, Function,*
49 *and Management.* Berlin: Springer-Verlag, pp. 218-240.

50
51 Naumburg, E., Housman, D., Huxman, T., Charlet, T., Loik, M., Smith, S., 2003.
52 Photosynthetic responses of Mojave Desert shrubs to Free Air CO₂ Enrichment are
53 greatest during wet years. *Glob. Change Biol.* 9, 276-285.

54
55
56 Ohlsson, K., Singh, B., Holm, S., Nordgren, A., Lövdahl, L., Högberg, P., 2005.
57 Uncertainties in static closed chamber measurements of the carbon isotopic ratio of
58 soil respired CO₂. *Soil Biol. and Biochem.* 37, 2273-2276.

- 1
2 Maestre, F.T. Quero, J.L. et al., Gotelli, N.J., Escudero, A., Ochoa, V., et al., 2012a.
3 Plant Species Richness and Ecosystem Multifunctionality in Global Drylands.
4 Science, 335, 214-218.
5
6
7 Maestre, F.T., Salguero-Gomez, R., Quero, J.L., 2012b. It is getting hotter in here:
8 determining and projecting the impacts of global environmental change on drylands.
9 Phil. Trans. R. Soc. B, 367, 3062-3075.
10
11 Reynolds, J., Smtih, D., Lambin, E., Turner II, B., Mortimore, M., Batterbury, S.,
12 Downing, T., Dowlatabadi, H., Fernández, R., Herrick, J., Huber-Sannwald, E., Jiang,
13 H., Leemans, R., Lynam, T., Maestre, F., Ayarza, M., Walker, B., 2007. Global
14 Desertification: Building a Science for Dryland Development. Science. 316, 847-851.
15
16
17 Rippka, R., Deruelles, J., Waterbury, J., Herdman, M., Stanier, R., 1979. Generic
18 assignments, strain histories and properties of pure cultures of cyanobacteria. J.
19 General Microbiol. 111, 1-61.
20
21
22 Simelton, E., Quinn, C.H., Batisani, N., Dougill, A.J., Dyer, J.C., Fraser, E.D.G.,
23 Mkwambisi, D.D. Sallu, S.M., Stringer, L.C. 2013. Is rainfall really changing?
24 Farmers' perceptions, meteorological data and policy implications. Climate and
25 Development, 5(2), 123-138.
26
27
28 Steven, B., Gallego-Graves, L., Yeager, C., Belnap, J., Evans, R.D., Kuske, C., 2012.
29 Dryland biological soil crust cyanobacteria show unexpected decreases in abundance
30 under long-term elevated CO₂. Environmental Microbiology, 14(12), 3247-3258.
31
32
33 Stringer, L.C., Dougill, A.J., Thomas, A.D., Spracklen, D.V., Chesterman, C., Ifejika-
34 Speranza, C., Rueff, H., Riddell, M., Williams, M., Beedy, T., Abson, D.,
35 Klintonberg, P., Syampungani, S., Powell, P., Palmer, A.R., Seely, M., Mkwambisi,
36 D.D., Falcao, M., Siteo, A., Ross, S., Kopolu, G. 2012. Challenges and opportunities
37 in linking carbon sequestration, dryland livelihoods and ecosystem service provision.
38 Environmental Science and Policy, 19-20, 121-135.
39
40
41 Thomas, A.D., 2012. Impact of grazing intensity on seasonal variations of soil organic
42 carbon and soil CO₂ efflux in two semi-arid grasslands in southern Botswana. Phil.
43 Trans. Royal Soc. Biol. Sci. 367, 3076-3086.
44
45
46 Thomas, A.D., Hoon, S., 2010. Carbon dioxide fluxes from biologically-cruste
47 Kalahari Sands after simulated wetting. J. Arid Env. 74, 131-139.
48
49
50 Thomas, A.D., Hoon, S., Dougill, A.J., 2011. Soil respiration at five sites along the
51 Kalahari Transect: Effects of temperature, precipitation pulses and biological soil
52 crust cover. Geoderma. 167-168, 284-294.
53
54
55 Thomas, A.D., Hoon, S., Linton, P., 2008. Carbon dioxide fluxes from cyanobacteria
56 crusted soils in the Kalahari. Appl. Soil Ecol. 39, 254-263.
57
58
59 Twomlow, S., Mugabe, F.T., Mwale, M., Delve, R., Nanja, D., Carberry, P., &
60 Howden, M., 2008. Building adaptive capacity to cope with increasing vulnerability
61
62
63
64
65

1 due to climatic change in Africa – A new approach. *Physics and Chemistry of the*
2 *Earth*, 33, 780–787.

3 Wang, L., D'Odorico, P., Ringrose, S., Coetzee, S., Macko, S., 2007. Biogeochemistry
4 of Kalahari sands. *J. Arid Env.* 71, 259-279.
5
6
7
8
9
10
11
12
13
14
15
16
17
18
19
20
21
22
23
24
25
26
27
28
29
30
31
32
33
34
35
36
37
38
39
40
41
42
43
44
45
46
47
48
49
50
51
52
53
54
55
56
57
58
59
60
61
62
63
64
65

FIGURE CAPTIONS

1
2
3 **Figure 1.** *Photograph of the dynamic gas exchange chamber.* A Teflon® film was
4 attached to the top of the chamber using strong adhesive tape, and the gas inlet/gas
5 outlet had open-cell foam inserts in order to allow pressure equilibration, but to
6 prevent gas diffusion. Gas inlets/outlets were attached using grommets which were
7 sealed using Instant Gasket. Gas samples were taken from the Suba-Seal® sampling
8 port (to the rear of the chamber in this image). A hole was drilled in the bottom of the
9 chamber in order that the samples could be inserted into the cell in a controlled
10 manner; during experiments this hole was sealed using high strength adhesive tape.
11
12
13
14
15
16
17
18
19
20
21
22
23
24
25

26 **Figure 2.** *Layout of DGECs within controlled environment cabinet.* The USB data
27 loggers (not shown) were placed at various points within the cabinet (one on top and
28 bottom shelf, two on middle shelf). A flow rate meter (not shown) was attached to the
29 gas feed line close to the point of exit of the main 32 l vessel.
30
31
32
33
34
35
36
37
38
39
40
41
42
43
44
45
46
47
48
49
50
51
52
53
54
55
56
57
58
59
60
61
62
63
64
65

1
2
3
4
5
6
7
8
9
10
11
12
13
14
15
16
17
18
19
20
21
22
23
24
25
26
27
28
29
30
31
32
33
34
35
36
37
38
39
40
41
42
43
44
45
46
47
48
49
50
51
52
53
54
55
56
57
58
59
60
61
62
63
64
65

Figure 3a & 3b. *Gas sample data from phases 1 & 2, samples with no additional liquid water, data presented as average values of three replicates for each treatment with error bars representing standard error. Gas sample data from phases 1 (Figure 3a) & 2 (Figure 3b) (392 ppm & 801 ppm CO₂, respectively, in air flush-gas), measuring carbon fluxes in chambers subject to no additional liquid water. Night-time (lights off) was 8 hours before 1 hour, between 17-25 hours and between 41-49 hours, after wetting. The left y-axis (Y1) corresponds to the solid dots / line (carbon flux of crust in chamber averaged over three chambers) and the right y-axis (Y2) corresponds to the dashed curve (internal temperature of cabinet). The Y1=0 line represents the point at which net carbon flux is zero. Y1=+ve → net respiration, Y1=-ve → net photosynthesis. The point at which water was added to the crusts is given by the line X=0.*

Figure 4a & 4b. *Gas sample data from phases 1 & 2, samples subject to 2 mm wetting treatment, data presented as average values of three replicates for each treatment with error bars representing standard error. Gas sample data from phases 1 (Figure 4a) & 2 (Figure 4b) (392 ppm & 801 ppm CO₂, respectively, in air flush-gas), measuring carbon fluxes in chambers subject to a 2 mm wetting treatment. Night-time (lights off) was 8 hours before 1 hour, between 17-25 hours and between 41-49 hours, after wetting. The left y-axis (Y1) corresponds to the solid dots / line (carbon flux of crust in chamber – averaged over three chambers) and the right y-axis (Y2) corresponds to the dashed curve (internal temperature of cabinet). The Y1=0 line represents the point at which net carbon flux is zero. Y1=+ve → net respiration, Y1=-ve → net photosynthesis. The point at which water was added to the crusts is given by the line X=0.*

1
2
3
4
5
6
7
8
9 **Figure 5a & 5b.** *Gas sample data from phases 1 & 2, samples subject to 5 mm*
10 *wetting treatment, data presented as average values of three replicates for each*
11 *treatment with error bars representing standard error. Gas sample data from phases*
12 *1 (Figure 5a) & 2 (Figure 5b) (392 ppm & 801 ppm CO₂, respectively, in air flush-*
13 *gas), measuring carbon fluxes in chambers subject to a 5 mm wetting treatment.*
14
15
16
17
18
19
20
21 Night-time (lights off) was 8 hours before 1 hour, between 17-25 hours and between
22
23 41-49 hours, after wetting. The left y-axis (Y1) corresponds to the solid dots / line
24
25 (carbon flux of crust in chamber – averaged over three chambers) and the right y-axis
26
27 (Y2) corresponds to the dashed curve (internal temperature of cabinet). The Y1=0 line
28
29 represents the point at which net carbon flux is zero. Y1=+ve → net respiration, Y1=-
30
31 ve → net photosynthesis. The point at which water was added to the crusts is given by
32
33 the line X=0.
34
35
36
37
38
39
40
41
42
43
44
45
46
47
48
49
50
51
52
53
54
55
56
57
58
59
60
61
62
63
64
65

HIGHLIGHTS

- Response to elevated atmospheric CO₂ of cyanobacterial samples was investigated
- Three wetting treatments were applied under fixed temperature and light conditions
- Newly designed dynamic gas exchange chambers were developed and used
- Samples subjected to 2 mm wetting sequestered 10 times more C when CO₂ was doubled
- Samples subjected to 5 mm wetting sequestered 3 times more C when CO₂ was doubled





Figure2
[Click here to download high resolution image](#)

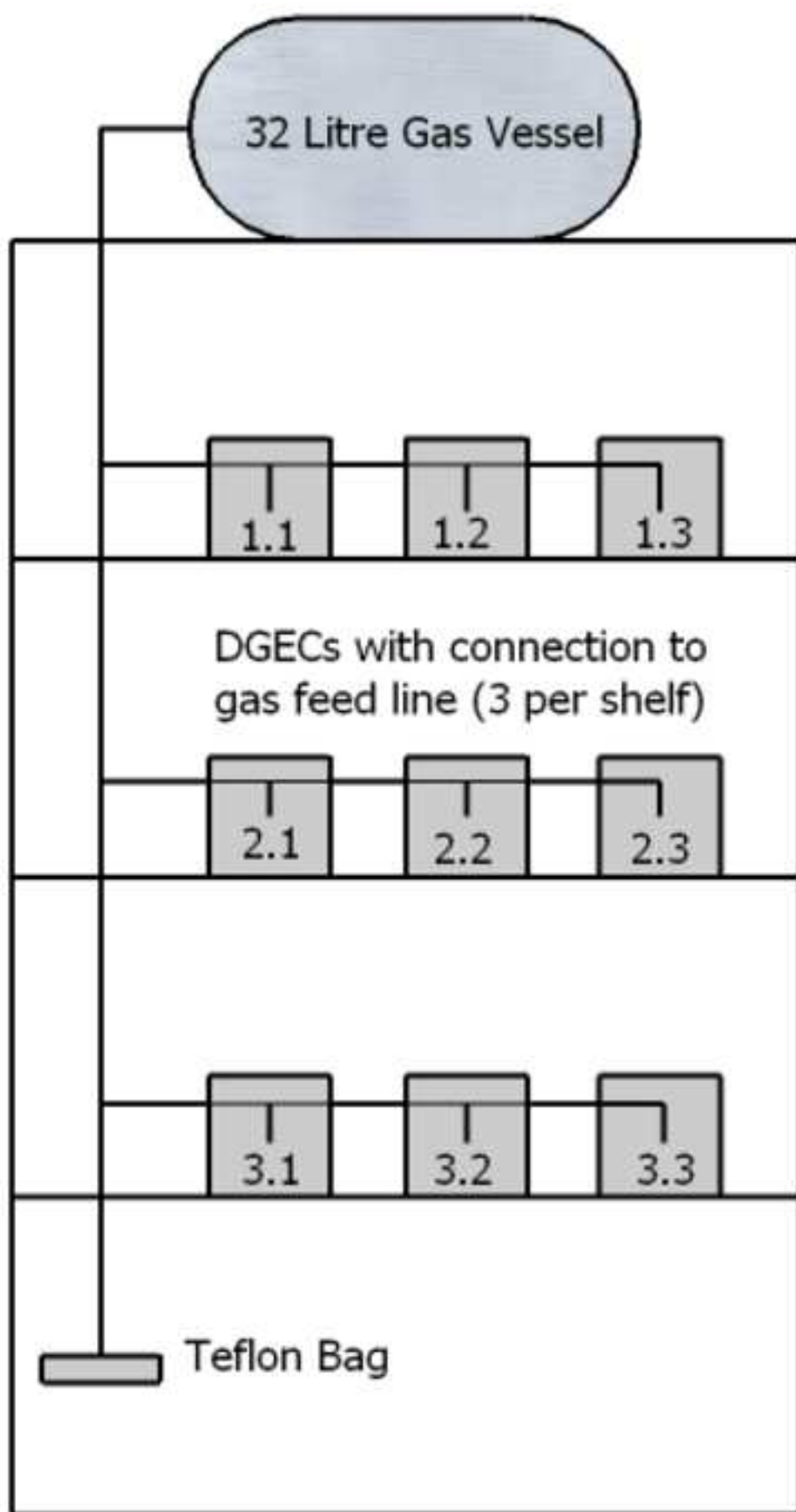


Figure3a

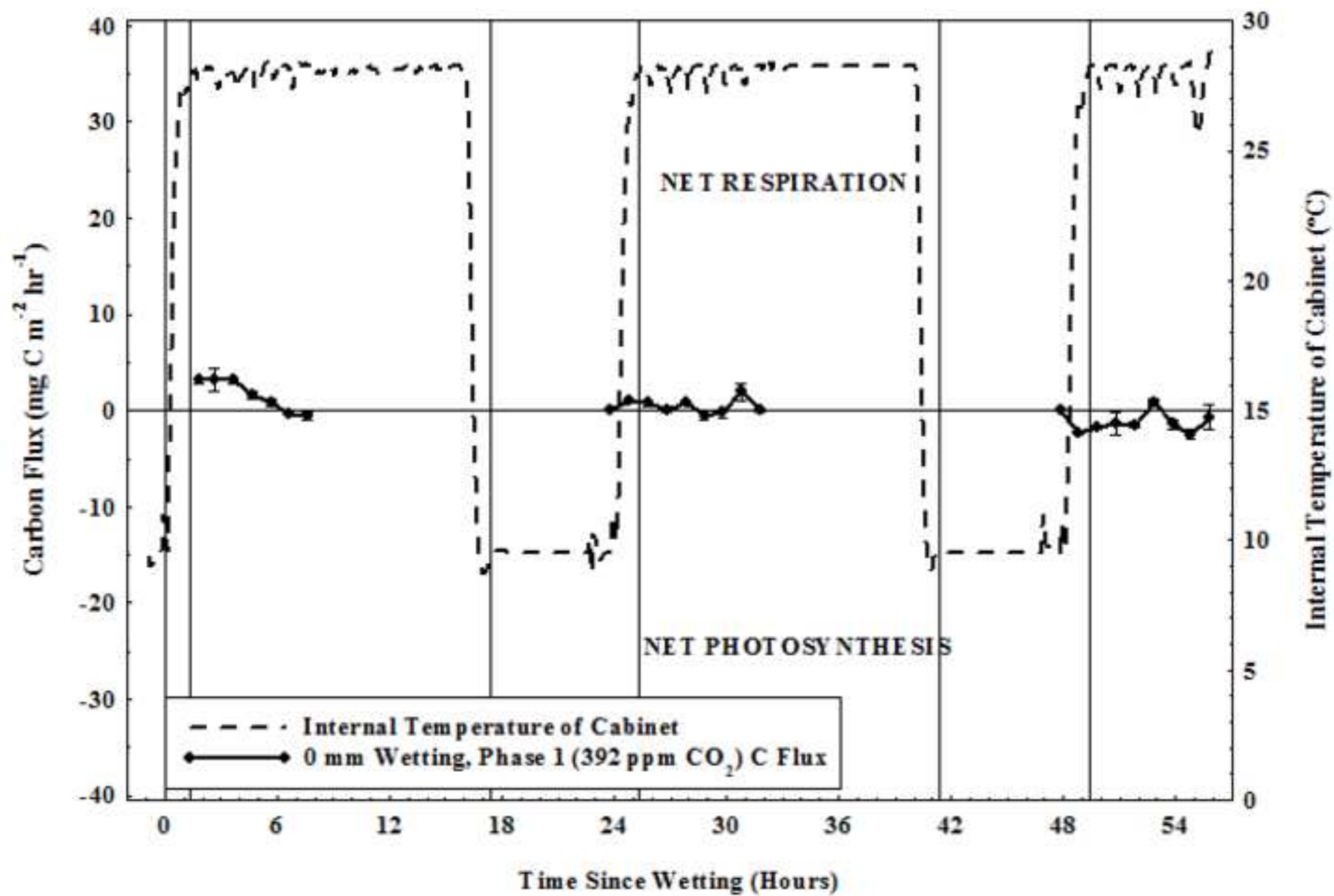
[Click here to download high resolution image](#)

Figure3b
[Click here to download high resolution image](#)

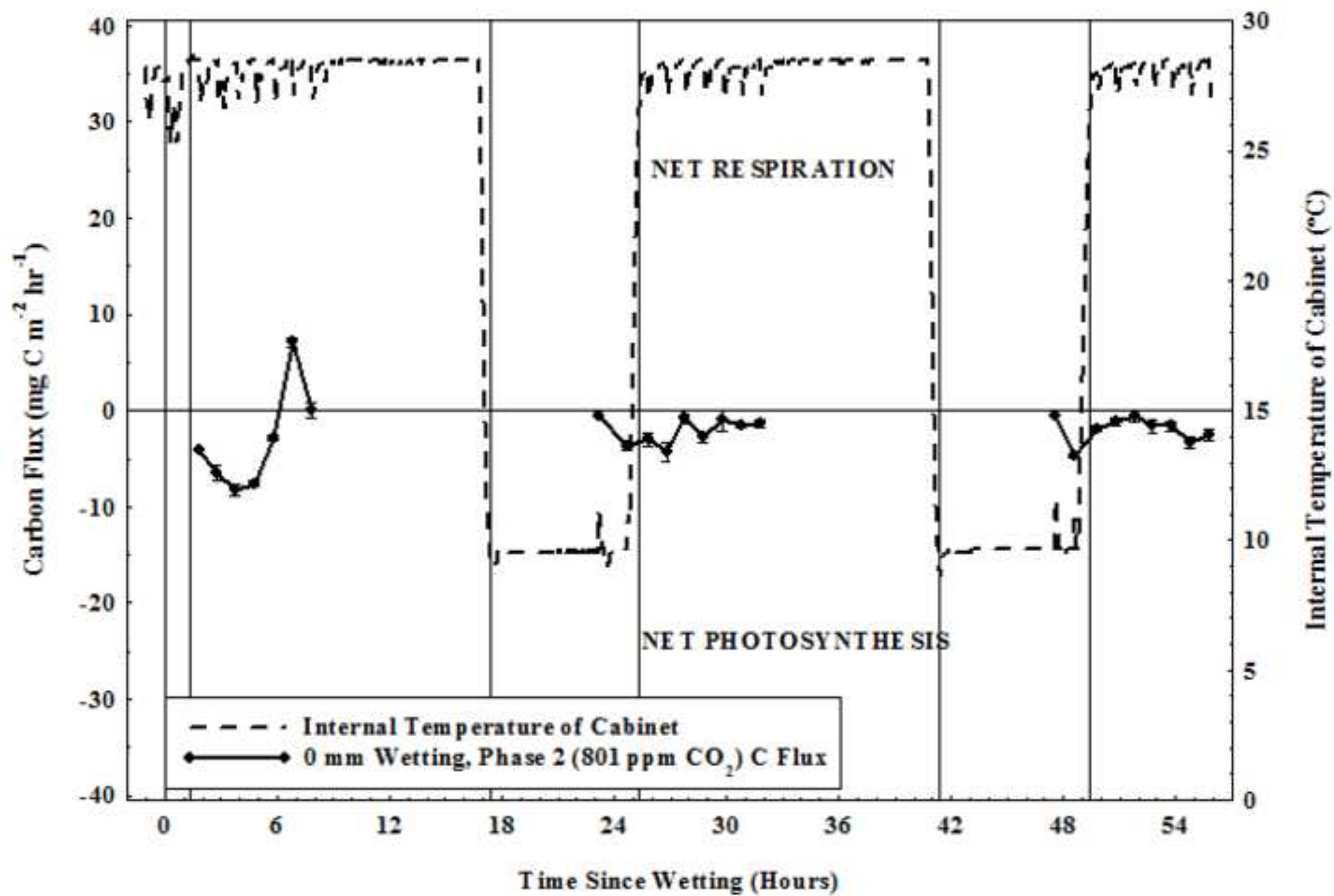


Figure4a

[Click here to download high resolution image](#)

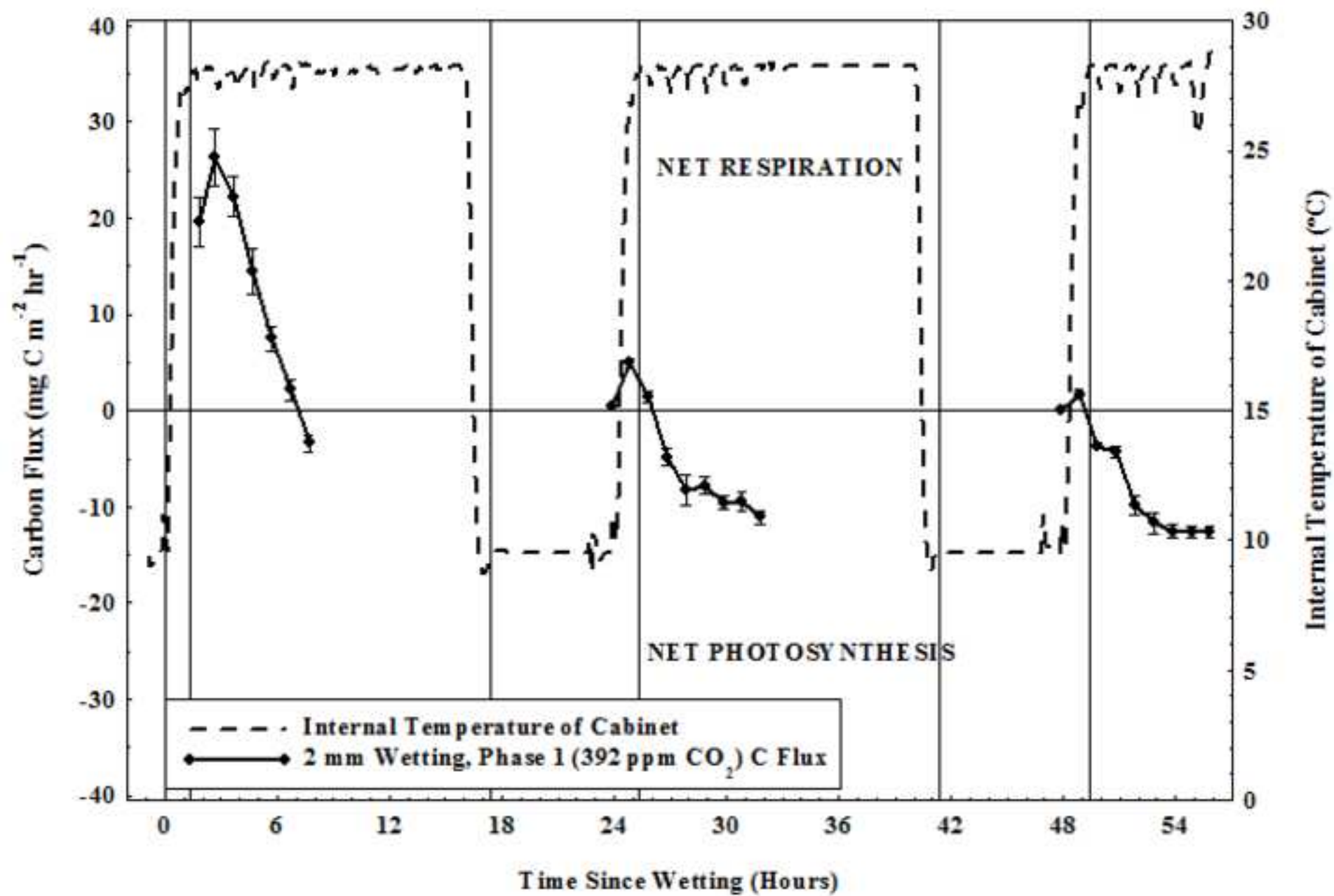


Figure4b
[Click here to download high resolution image](#)

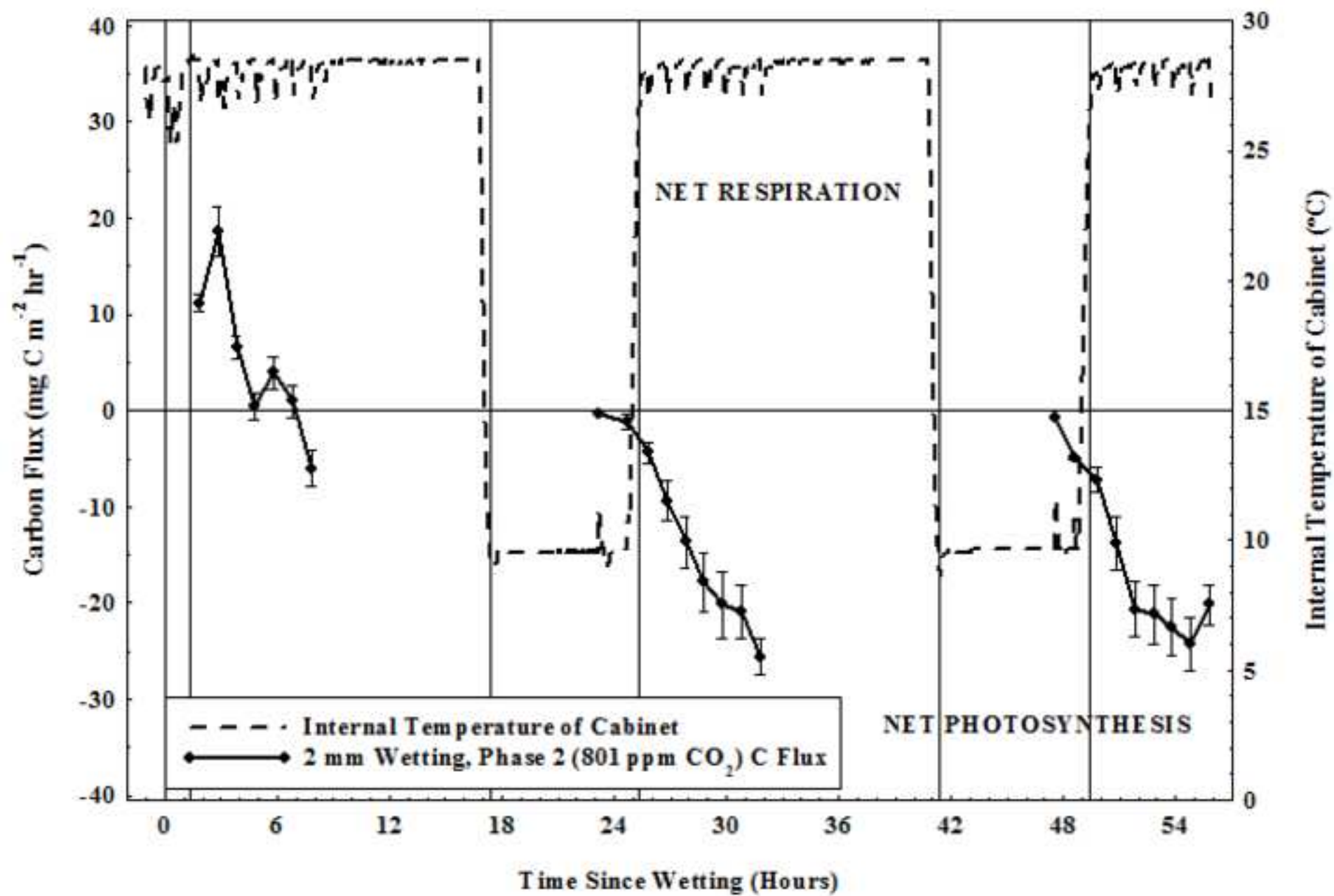


Figure5a

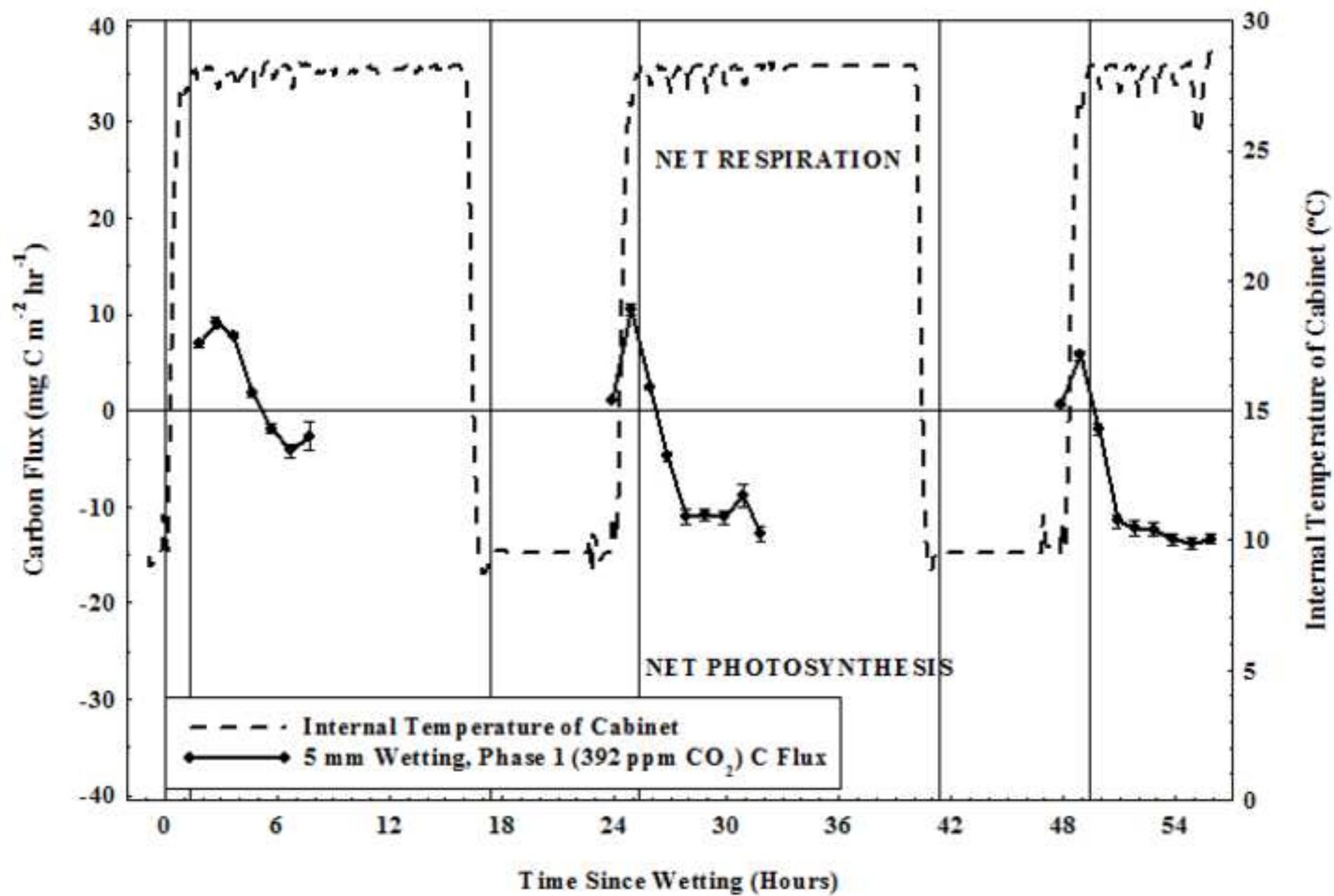
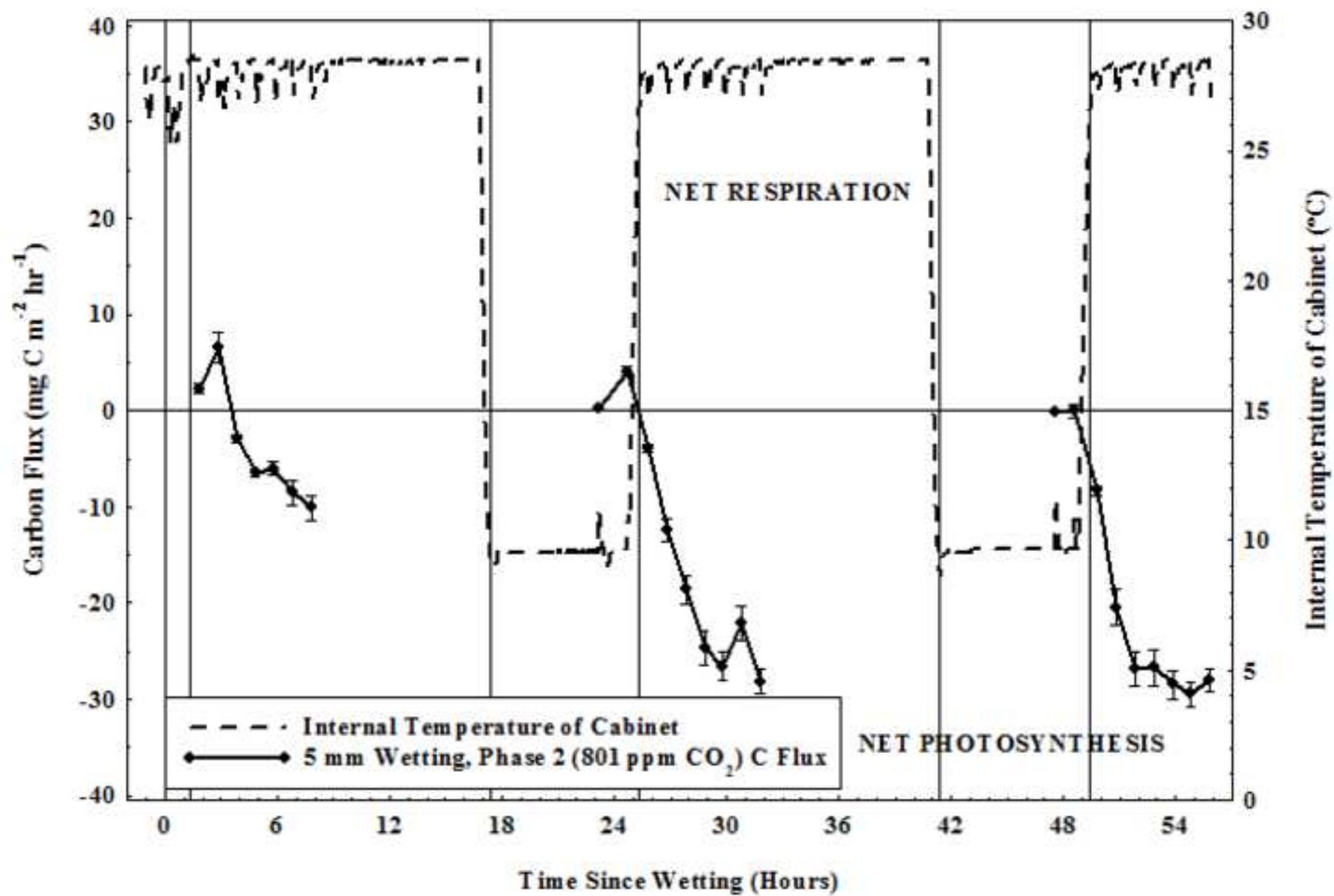
[Click here to download high resolution image](#)

Figure5b
[Click here to download high resolution image](#)



TABLES

Table 1. Carbon balances for each chamber during Phase 1 (392 ppm CO₂). Chambers 1.2-1.3 had no additional water, chambers 2.1-2.3 each had a 2 mm wetting treatment and chambers 3.1-3.3 each had a 5 mm wetting treatment.

Carbon Balance (mg C) (+ve = efflux, -ve = sequestration)					
Chamber	Day 1	Day 2	Day 3	Net	Average for each chamber group (±SE)
1.1	0.119	0.021	-0.098	0.041	
1.2	0.030	0.013	-0.024	0.020	
1.3	0.033	0.046	-0.082	-0.003	0.02 ± 0.01
2.1	0.431	-0.163	-0.330	-0.062	
2.2	0.775	-0.300	-0.421	0.055	
2.3	0.354	-0.324	-0.450	-0.420	-0.14 ± 0.14
3.1	0.120	-0.307	-0.420	-0.607	
3.2	0.085	-0.199	-0.428	-0.541	
3.3	0.068	-0.293	-0.487	-0.712	-0.62 ± 0.05

Table 2. Carbon balances for each chamber during Phase 2 (801 ppm CO₂). Chambers 1.2-1.3 had no additional water, chambers 2.1-2.3 each had a 2 mm wetting treatment and chambers 3.1-3.3 each had a 5 mm wetting treatment.

Carbon Balance (mg C) (+ve = efflux, -ve = sequestration)					
Chamber	Day 1	Day 2	Day 3	Net	Average for each chamber group (±SE)
1.1	-0.109	-0.096	-0.163	-0.369	
1.2	-0.174	-0.190	-0.102	-0.466	
1.3	-0.125	-0.114	-0.082	-0.321	-0.39 ± 0.04
2.1	0.045	-0.703	-0.880	-1.538	
2.2	0.317	-1.067	-1.217	-1.966	
2.3	0.304	-0.284	-0.468	-0.449	-1.3 ± 0.5
3.1	-0.145	-0.621	-0.845	-1.611	
3.2	-0.076	-0.811	-1.115	-2.001	
3.3	-0.215	-0.946	-1.194	-2.356	-2.0 ± 0.2