



This is a repository copy of *The Role of Simple Techniques in Model Order Reduction Backed by Fast Interactive Simulation to Verify Model Accuracy*.

White Rose Research Online URL for this paper:  
<http://eprints.whiterose.ac.uk/76191/>

---

### Monograph:

Morris, A.S. (1982) *The Role of Simple Techniques in Model Order Reduction Backed by Fast Interactive Simulation to Verify Model Accuracy*. Research Report. ACSE Report 175 . Department of Control Engineering, University of Sheffield, Mappin Street, Sheffield

---

### Reuse

Unless indicated otherwise, fulltext items are protected by copyright with all rights reserved. The copyright exception in section 29 of the Copyright, Designs and Patents Act 1988 allows the making of a single copy solely for the purpose of non-commercial research or private study within the limits of fair dealing. The publisher or other rights-holder may allow further reproduction and re-use of this version - refer to the White Rose Research Online record for this item. Where records identify the publisher as the copyright holder, users can verify any specific terms of use on the publisher's website.

### Takedown

If you consider content in White Rose Research Online to be in breach of UK law, please notify us by emailing [eprints@whiterose.ac.uk](mailto:eprints@whiterose.ac.uk) including the URL of the record and the reason for the withdrawal request.



[eprints@whiterose.ac.uk](mailto:eprints@whiterose.ac.uk)  
<https://eprints.whiterose.ac.uk/>



THE BENCH MINING SYSTEM:  
PROGRESS IN TWO-DIMENSIONAL SIMULATION OF STEERING CHARACTERISTICS

by

J.B. Edwards

Department of Control Engineering,  
University of Sheffield,  
Mappin Street, Sheffield S1 3JD.

Research Report No. 176

March 1982



## THE BENCH MINING SYSTEM:

### Progress in Two-Dimensional Simulation of Steering Characteristics

by

J.B. Edwards

#### 1. Introduction

Preliminary computer simulations to demonstrate the usefulness of colour graphics for investigating the vertical steering characteristics of novel mining systems, (such as the thick seam Bench system), were imperfect. The logic used to fit the structures to the cut floor allowed unwanted penetration of the floor under some circumstances since not all possible system states had been envisaged at the outset. Over recent months, effort has been directed towards correcting this deficiency of the simulation programs. This report reviews the progress made.

#### 2. Bench Fitting

Two mechanically interacting types of structure are involved in the Bench system of mining, i.e. :

- (a) the benches themselves which carry the power loader and armoured face conveyor;
- and (b) the roof supports (chocks) which provide a safe walkway for men on the face.

Since this study is only two-dimensional, only one bench and one chock are considered and these are sketched in end-elevation in Fig. 1. In this Section we consider the fitting of the bench alone to a stepped floor cut by the vertically ranging cutting drum over a series of passes. As illustrated in Fig. 2 the bench, together with its trailing beam, is assumed to bridge six passes (or drum widths) and to have its centre of gravity between ordinates  $h_2$  and  $h_3$ . Heights  $h_1 \dots h_6$  are the bench beam heights at the cut floor steps whilst  $f_1 \dots f_6$  are the heights of the tops of the steps. The fitting problem is to calculate  $h_1 \dots h_6$  given  $f_1 \dots f_6$

the latter ordinates being obtained from a knowledge of previous cut-floor heights  $y$ , bench heights  $h$ , and steering jack deflections  $J$  thus

$$f_i = y_{i-1} \quad , \quad y_{i-1} > h_i + J_i \quad (1)$$

$$f_i = h_i + J_i \quad , \quad y_{i-1} < h_i + J_i \quad (2)$$

The validity of equations (1) and (2) is obvious from inspection of Fig. 3. The flowchart of Fig. 4 describes the program functions to obtain the bench fit. With the aid of the comment statements included, the flowchart is reasonably self-explanatory. Carefully designed tests on a program developed from Fig. 4 were unable to fault the fitting logic. In this report, results are postponed until Section 3 which describes how the interaction with the chock has been included.

### 3. Bench/Chock Interaction

The chock-base resembles a catamaran bridging the trailing beams of the bench structure as illustrated in Fig. 5. We here assume that the bridge is located at a distance  $b$  drum-width's from the leading - (i.e. face-side) edge of the bench. The limited height  $B$  of the bridge clearly causes the following interaction between bench height profile  $h$  and chock-base height profile  $c$ :

$$h_b \leq c_b + B \quad (\text{beam unsupported by } f_b \dots f_6) \\ \text{i.e. } h_i > f_i, \quad b < i \leq 6 \quad (3)$$

$$c_b \geq h_b - B \quad (h_i = f_i, \quad b < i \leq 6) \quad (4)$$

Assuming a similar fitting routine to that for the bench applies to the fitting of the chock-base profile  $c_2 \dots c_8$  to  $f_2 \dots f_8$ , then the above interactions are readily accounted for by means of the routine outlined in the flowchart of Fig. 6.

Figs. 7(1) to 7(10) show the results obtained for a variety of floor profiles  $f_1 \dots f_8$ . The bridge is located midway between ordinates  $f_3$  and  $f_4$  (i.e. at  $f_{3.5}$ ) and its height indicated by the short vertical line

superimposed on the sloping straight line defining the underside of the chock-base. In Figs. 7(1) to 7(4), no interaction occurs but in Fig. 7(5) the chock-base is raised at its leading edge because the bench is supported to left and right by the cut floor. The same phenomenon occurs in Fig. 7(7). In Fig. 7(9), the bench is raised off  $f_2$  by interaction with the chock-bridge as shown and a more severe case occurs in Fig. 7(10).

It is clear from the results of Fig. 7(1) to 7(10) that all floor penetration has now been eliminated and the fitting routines were therefore incorporated into the colour graphics simulation programs. The bridge-height,  $B$ , has been assumed to be a preset constant value but, in practice, this could be varied by actuation of the vertical clamping ram shown in Fig. 5 to provide an additional control on the bench and chock steering. Varying  $B$  from cut-to-cut, manually or automatically would pose no serious a problem in simulation.

4. Results obtained from Colour Graphics Simulator

Fig. 8 shows the behaviour of the system in negotiating a 30 inch downward step following the simple automatic control law:

$$J_i = k(h_r - h_i) ; |k(h_r - h_i)| < J_m \quad (5)$$

$$J_i = \text{sign}(h_r - h_i) J_m, |k(h_r - h_i)| > J_m \quad (6)$$

where  $k$  is the controller gain,  $J_m$  the maximum allowable drum-arm deflection and  $h_r$  the desired horizon height. Here  $k$  was set at unity and  $J_m = 10$  inch. The value of  $B$  was set at 10 inch to cause little interaction. The effect of setting  $B = 1$  inch is clearly shown by Fig. 9 which was obtained for the same automatic control strategy. The initial toppling of the bench after cut 3 is clearly limited by the bridge constraint causing marginally less undershoot of the desired horizon. Judicious use

of the clamping ram can therefore help correct excessive use of the ranging arm after the event.

Fig. 10 illustrates how, despite use of a high bridge, careful manual control of the ranging arm permits the desired horizon to be attained with a much-reduced undershoot. Fig. 11 is included not to demonstrate good control but to show the robustness of the simulation in dealing with severe conditions in the cut floor. Here manual control has been exercised deliberately in the wrong (i.e. upward) direction initially. Note that nowhere in the transient does the bench or chock-base penetrate the (blue) cut floor.

Finally Fig. 12 is included to show the performance of a bench with a cut-away base. The bench beam is relieved to allow all steps between front trailing edges to be bridged. This does exclude the toppling phenomenon associated with flat beams and allows far-easier simulation and analysis. It is here included for academic interest only. Control is automatic as for Fig. 8 and clearly reveals less undershoot of the desired horizon.

## 5. Discussion and Conclusion

The problem of unwanted floor penetration by the bench structure simulation would now seem to have been solved. Furthermore, given a proper fit for the roof-support, the effect of the interaction between roof support and bench (via the catamaran bridge) can and has been incorporated into the simulation routine.

The roof-support fitting routine (which at present closely resembles that of the bench) works well for carefully graded floors, and a similar routine for the roof-beam behaves similarly (see Figs. 8-10). However, these routines are based on a forward-located centre of gravity (or centre of pressure) which is appropriate for chocks having a very short front

extension but less so for the long-based chocks used in conjunction with the bench system. Furthermore, we should perhaps question whether some floor and roof penetration ought not to be allowed in the case of chock steering because of the enormous forces involved. Further work should be done to allow for step degradation to the point where, say compressive strength (of coal or stone)  $\times$  contact area = roof support yield force. This question is currently under investigation.

In summary therefore we may conclude that a satisfactory 2-D bench simulator has now been achieved but roof-support simulation requires further research effort.

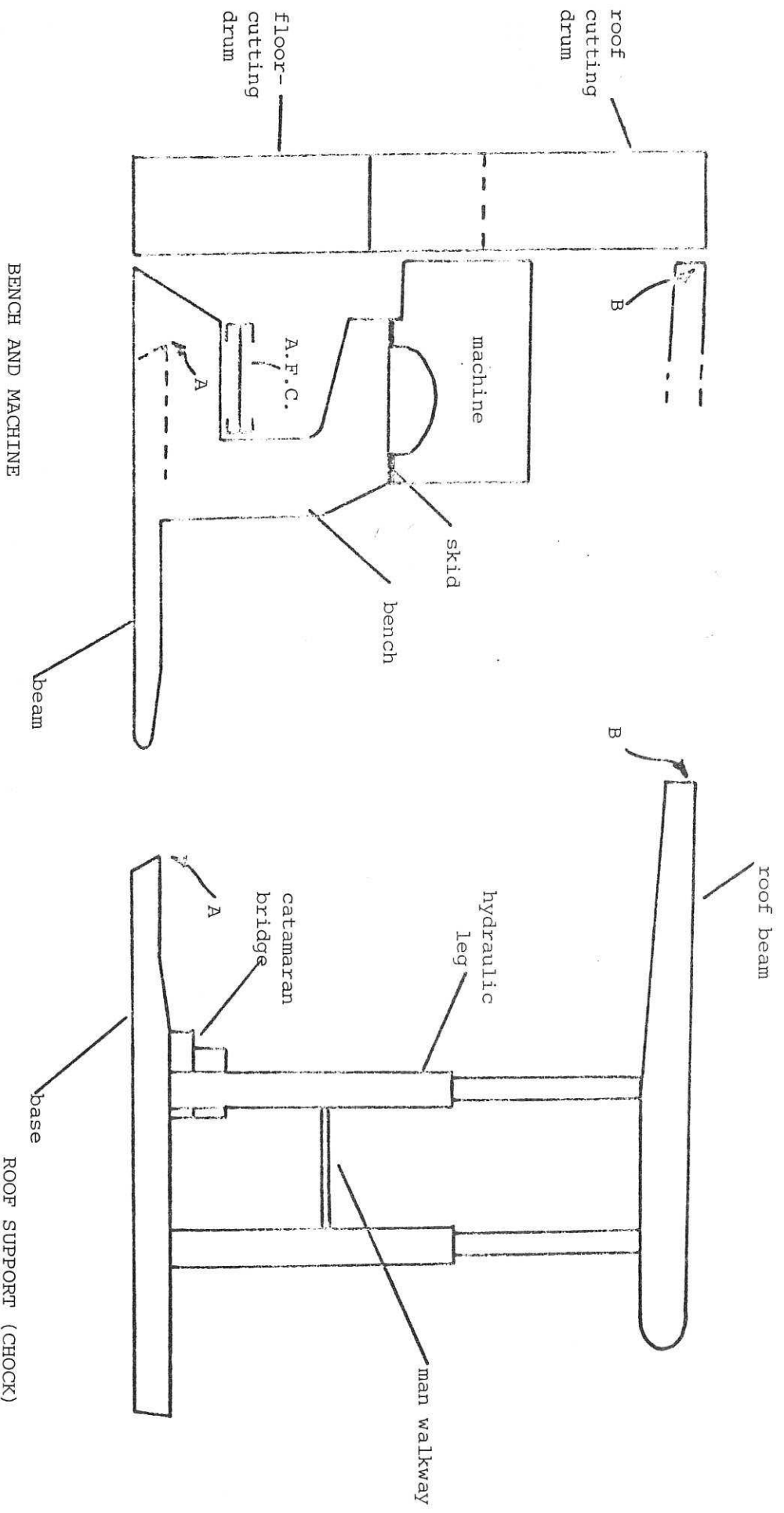

Fig. 1 Bench Mining System



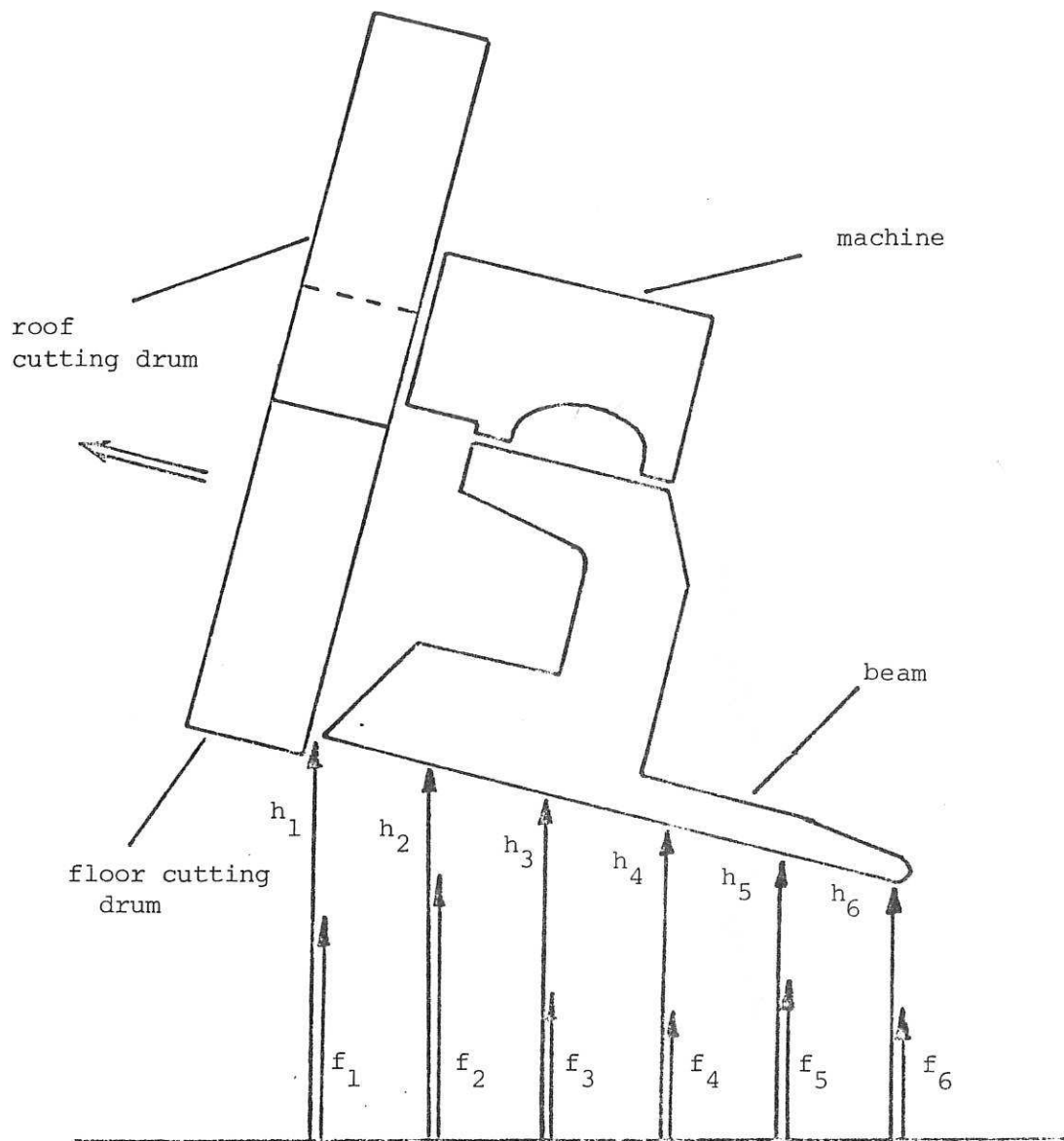

Fig. 2 Showing ordinates of bench and cut-floor

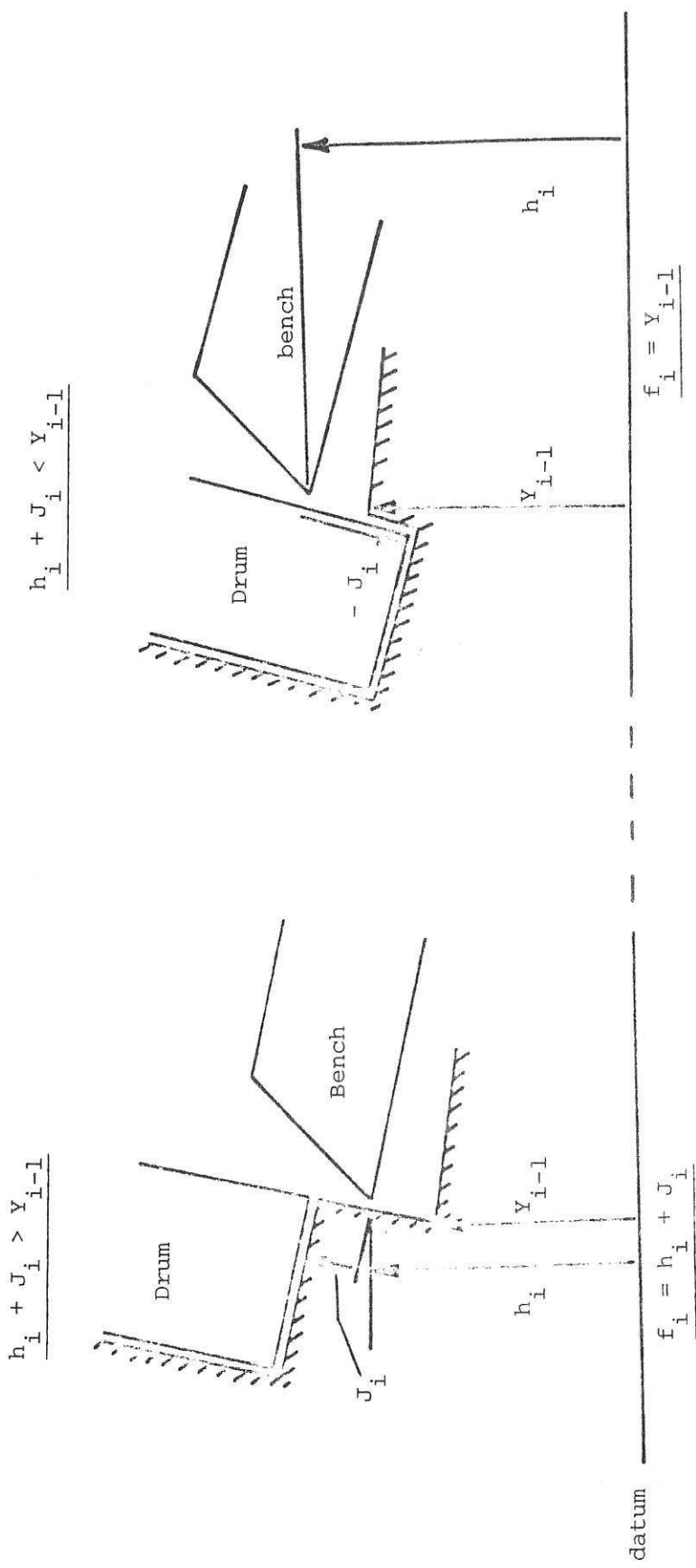

Fig. 3 Finding the f-profile

set up profile  $f_1, f_2 \dots f_6$

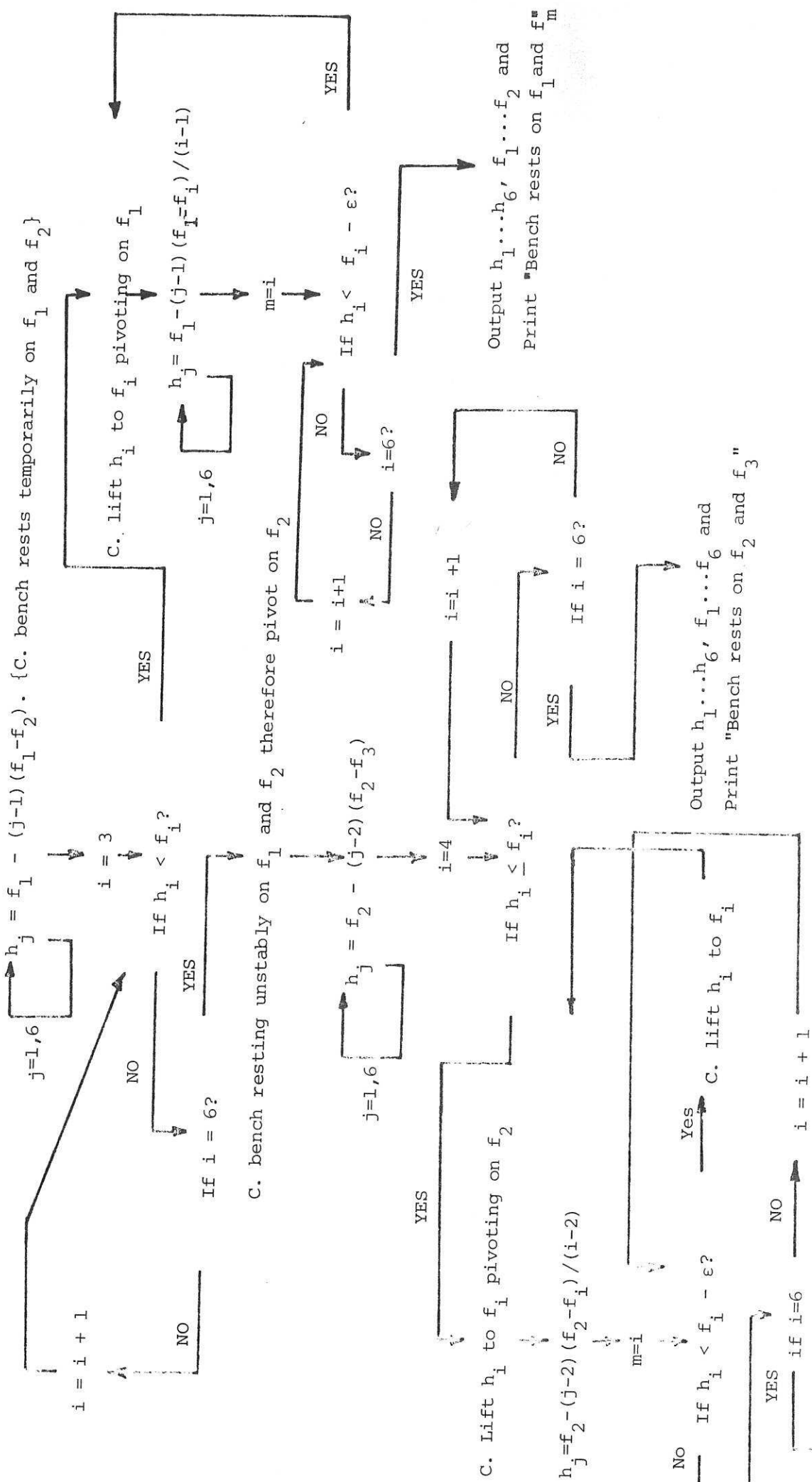
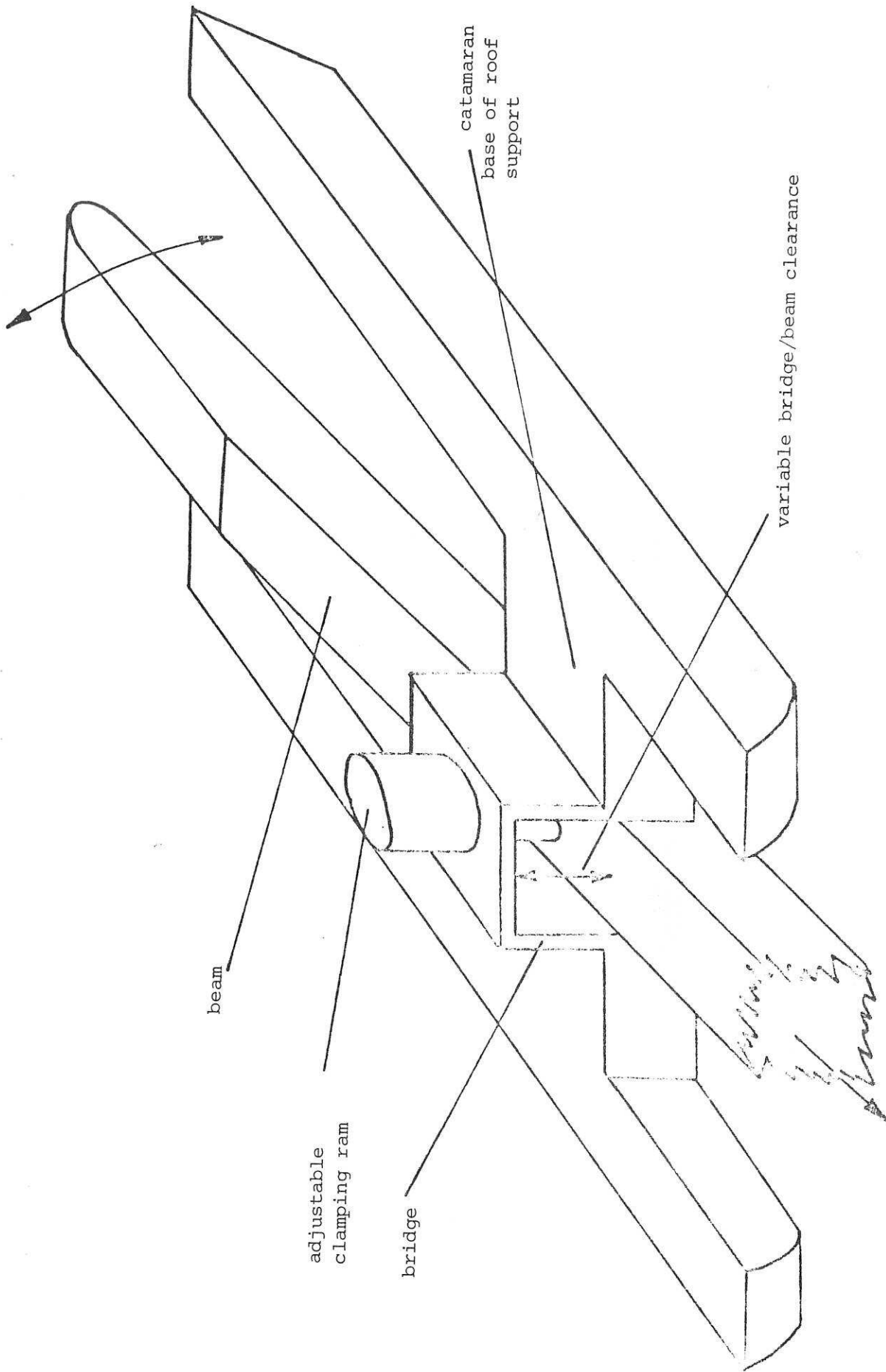

Fig. 4 Bench-fitting Flowchart



to remainder of bench structure

Fig. 5 Showing Catamaran structure of roof support base

Fig. 6 Flowchart for simulating bench/chock interactions

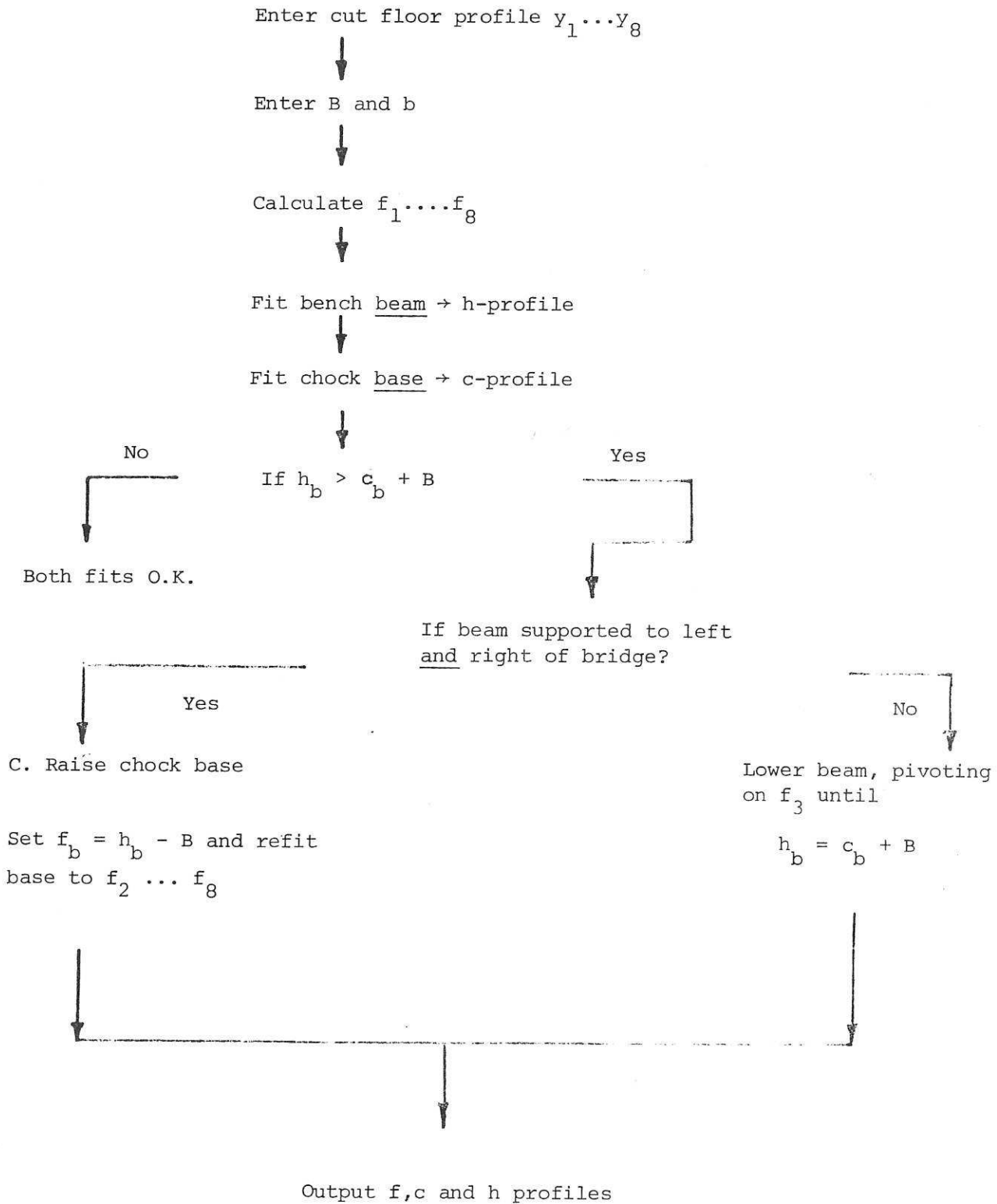

Figure 7(1) Fitting program tests

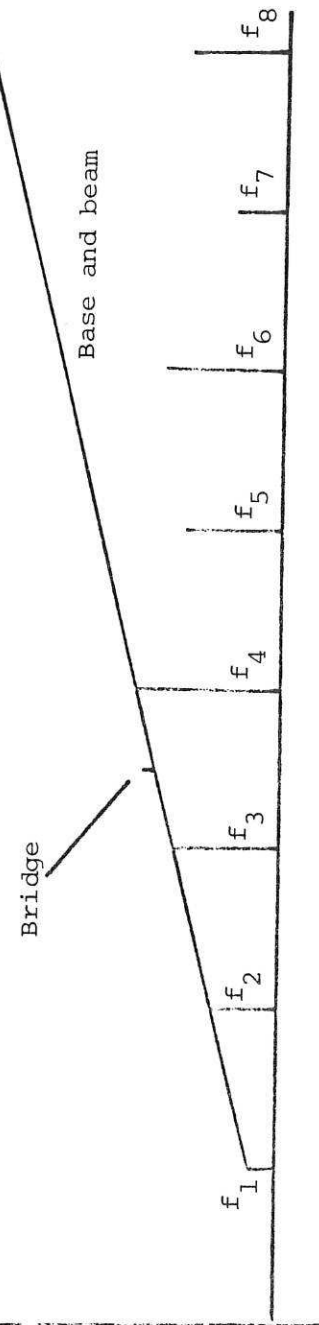
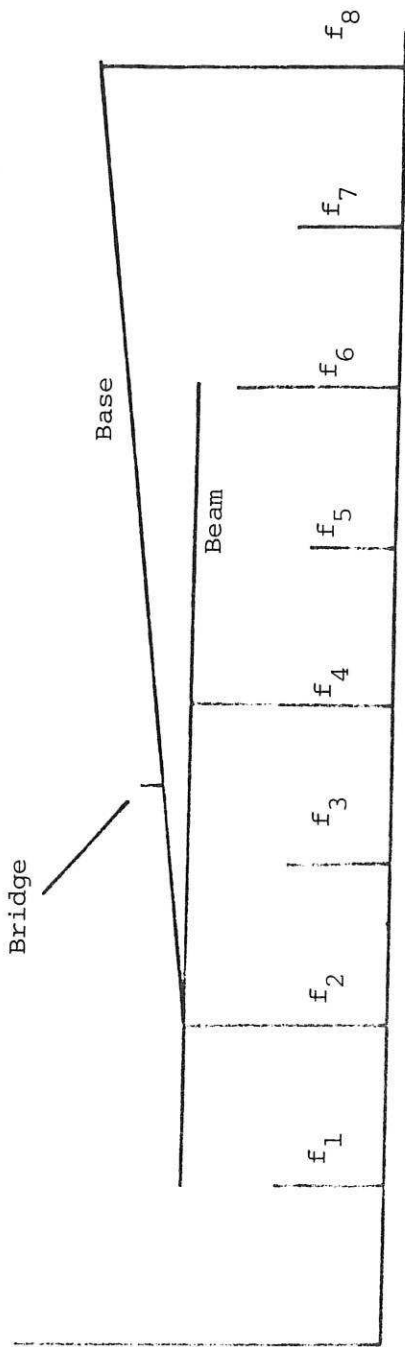

Fig. 7(2)

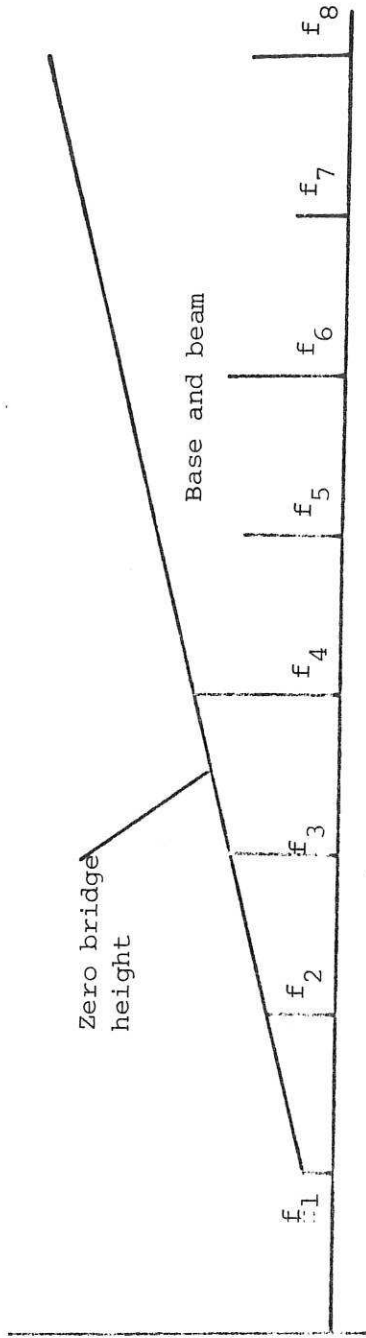

Fig. 7(3)

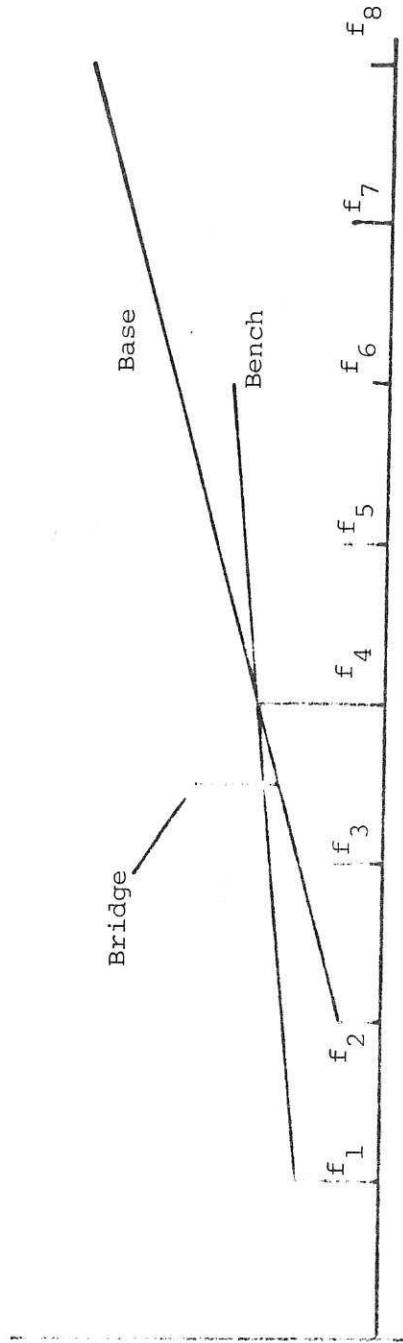

Fig. 7(4)

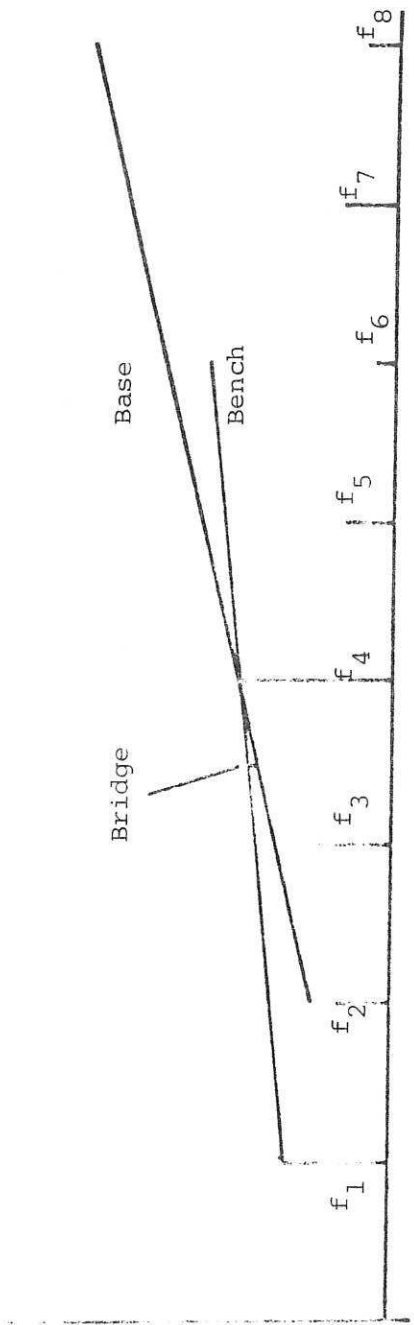

Fig. 7(5)

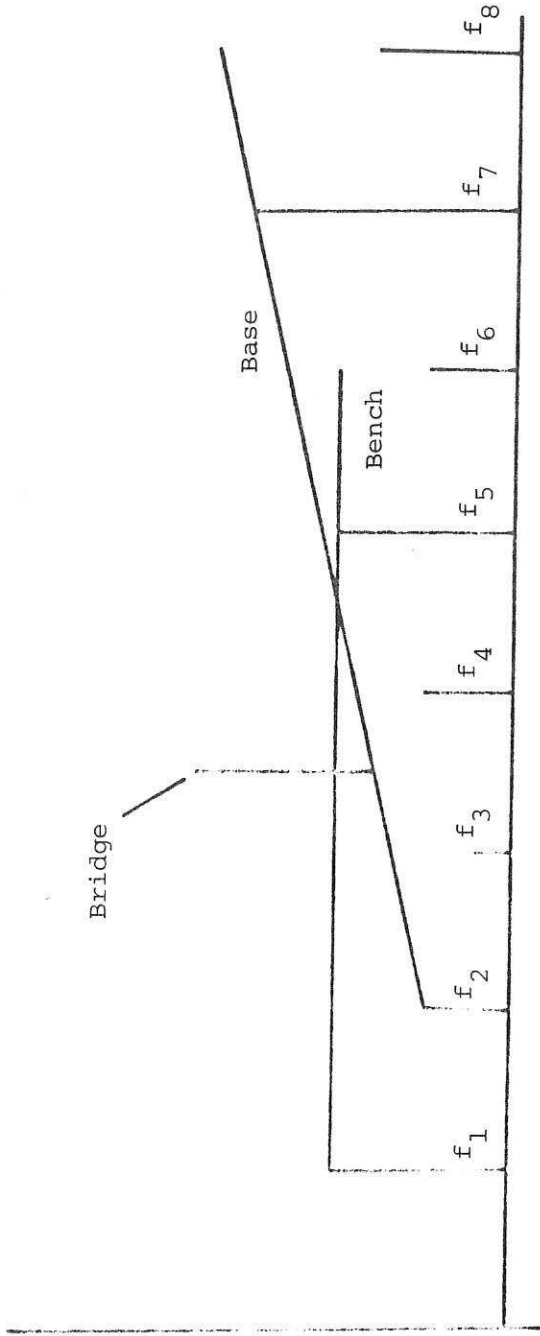

Fig. 7(6)



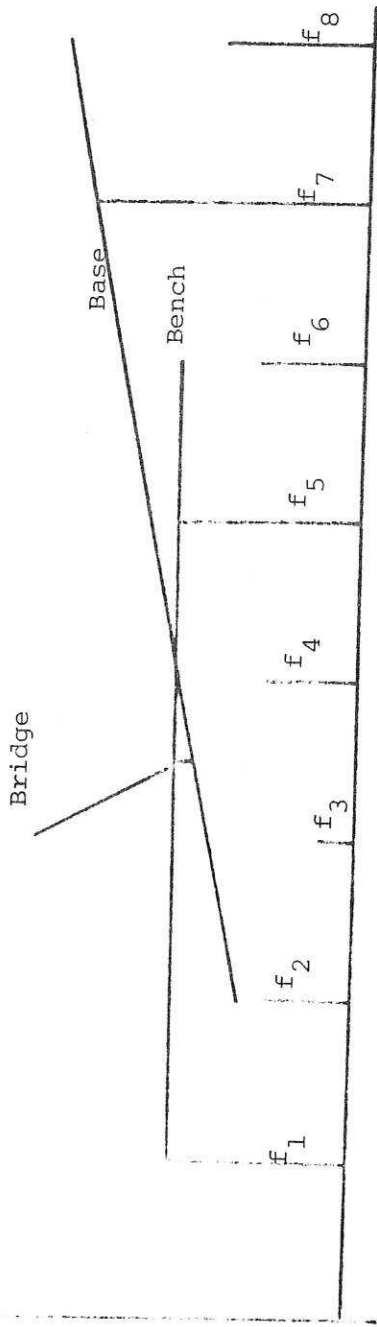

Fig. 7(7)

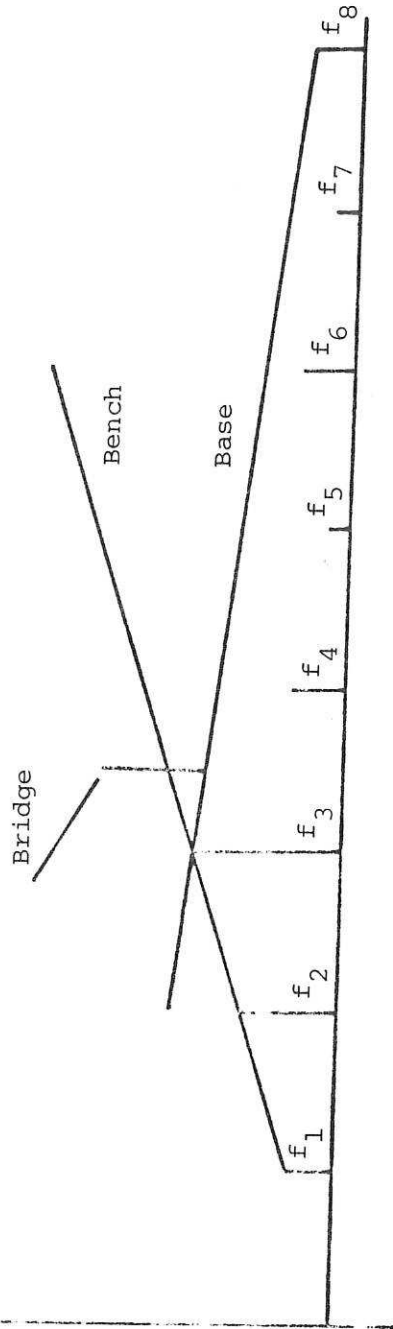

Fig. 7(8)

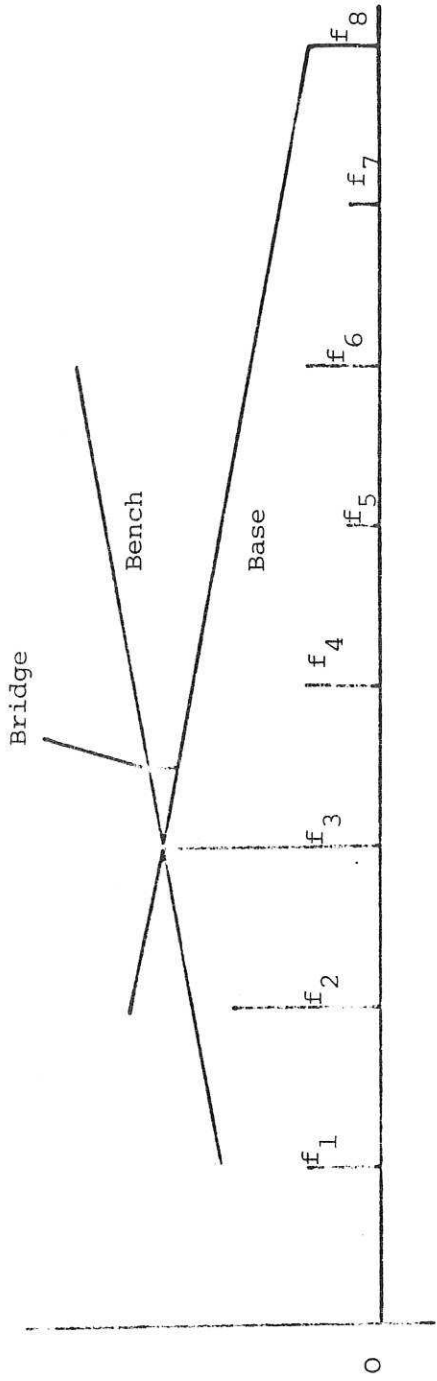

Fig. 7(9)

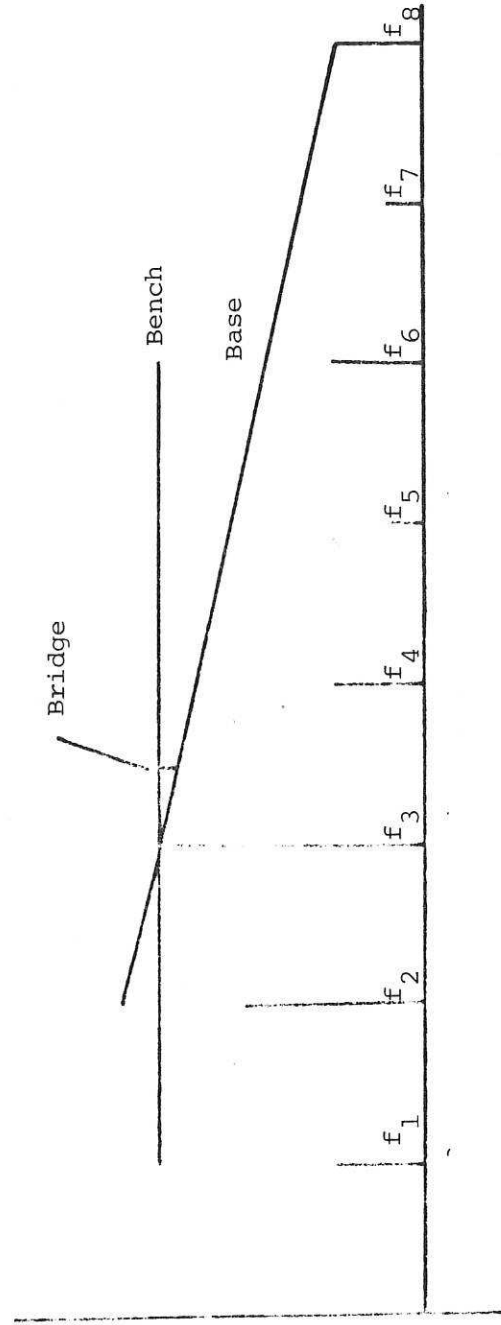

Fig. 7(10)

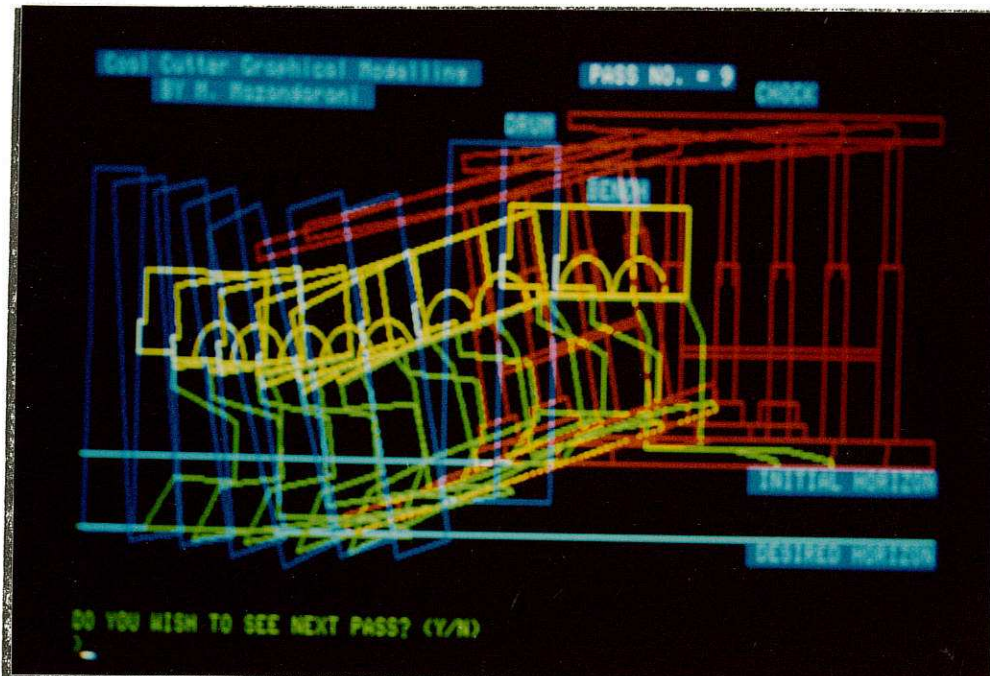

Fig. 8 Automatic Control, bridge height = 10 inch

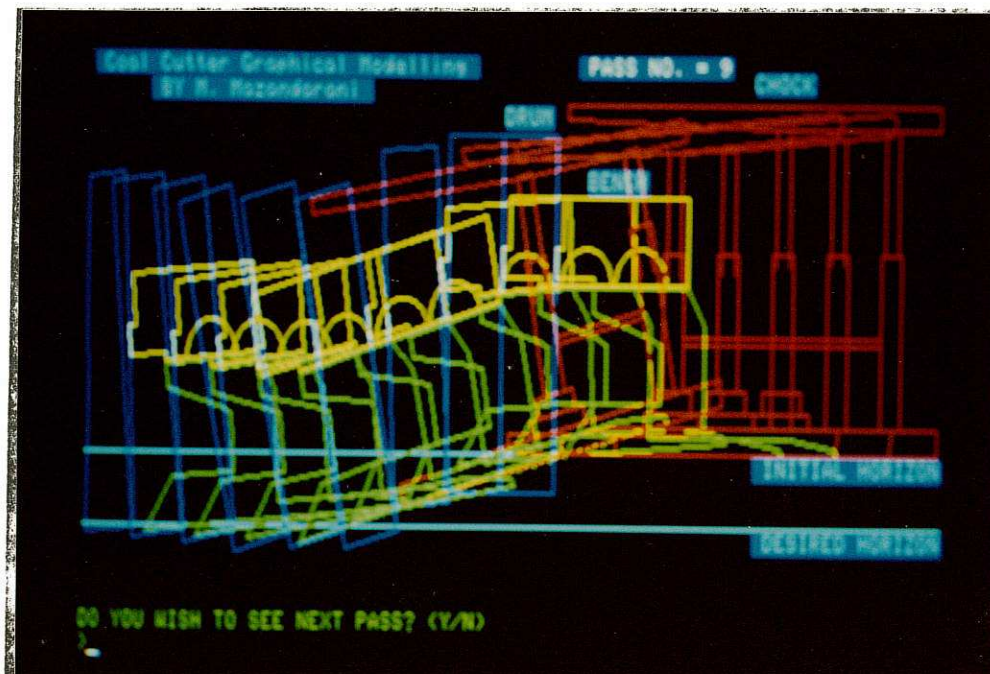

Fig. 9 Automatic control, bridge height = 1 inch

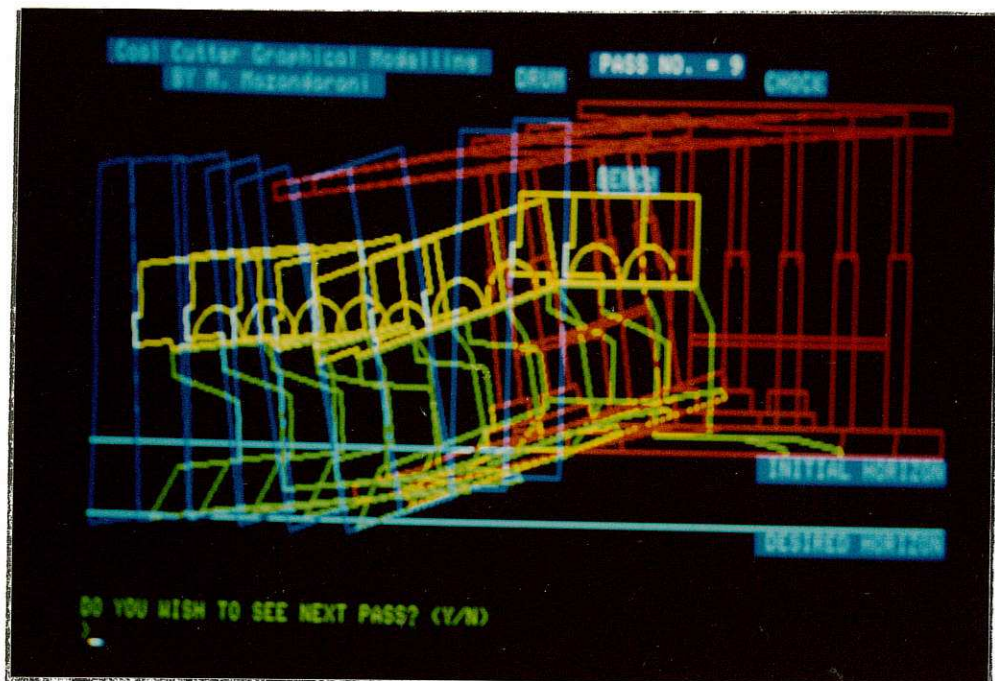

Fig. 10 Careful manual control, bridge height = 10 inch



Fig. 11 Careless manual control, bridge height = 10 inch

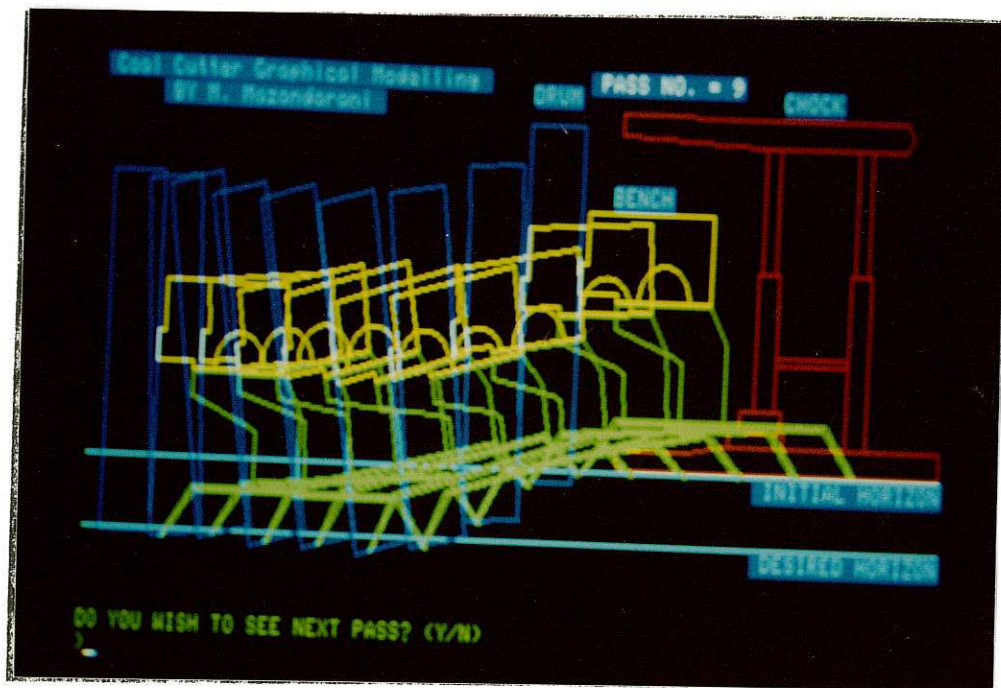

Fig. 12 Cutaway bench profile : Automatic Control