

promoting access to White Rose research papers



Universities of Leeds, Sheffield and York
<http://eprints.whiterose.ac.uk/>

This is the publisher's version of a Proceedings Paper presented at the **2009 IEEE International Ultrasonics Symposium**

Arif, M and Freear, S (2009) *Fractional Fourier Transform with Pulse Inversion for Second Harmonic Pulse Compression*. In: 2009 IEEE International Ultrasonics Symposium Proceedings. UNSPECIFIED. IEEE , 1227 - 1230. ISBN 978-1-4244-4389-5

White Rose Research Online URL for this paper:

<http://eprints.whiterose.ac.uk/id/eprint/75993>

Fractional Fourier Transform with Pulse Inversion for Second Harmonic Pulse Compression

Muhammad Arif and Steven Freear

Ultrasound Group, School of Electronic and Electrical Engineering, University of Leeds, Leeds LS2 9JT, UK
Emails: [elma, s.freear]@leeds.ac.uk. Telephone: +44 (0) 113 343 2076. Fax: +44 (0) 113 343 2032.

Abstract—In ultrasound harmonic imaging with chirp coded excitation, harmonic matched filtering (HMF) is required on the receiving side to perform second harmonic pulse compression to recover signal axial resolution. In the compressed signal, peak sidelobe levels will grow and the mainlobe width may increase under mismatched or overlap harmonic conditions. In this paper, fractional Fourier transform (FrFT) with pulse inversion is proposed for the second harmonic pulse compression. Experimental results are presented which show a, 13.5%, improvement in the mainlobe width, with comparable peak sidelobe levels, when compared with the conventional HMF technique.

Index Terms—Ultrasound imaging, fractional Fourier transform, pulse inversion, linear frequency modulation, harmonic pulse compression.

I. INTRODUCTION

Over the last two decades, ultrasound diagnostic imaging based on nonlinear second harmonic component (SHC) has become popular in clinical practice. In general, there are two approaches to get these nonlinear SHC namely: tissue harmonic imaging (THI), and contrast harmonic imaging (CTI). In THI, the SHC is produced due to finite amplitude distortion of nonlinear propagating ultrasound waves through biological tissue. Whereas in CHI, these second or higher harmonic components are produced due to nonlinear backscattering from microbubbles, which are oscillating at their resonance frequency. Both THI and CHI techniques exploit these nonlinear SHC and form the image with improved spatial and contrast resolutions and with reduced unwanted reverberation and sidelobes artifacts [1], [2].

The main issues in ultrasound harmonic imaging are the low signal-to-noise ratio (SNR) of the generated nonlinear SHC and the overlapping between the harmonic components [3]. Coded excitation with linear frequency modulated (LFM) chirp signals offers the potential to improve the SNR of the SHC without increasing the average excitation power. The HMF is required on the receiving side to perform the extraction and compression of the SHC to recover signal axial resolution [4].

In HMF technique, the optimal pulse compression of SHC requires the optimal window function and prior knowledge of the instantaneous frequency and bandwidth components. Also under overlap harmonic and mismatched conditions, the sidelobes level will grow and the mainlobe width may increase in the compressed SHC signal [5].

Fractional Fourier transform (FrFT) is a time-frequency transform which uses chirp as a basis function. FrFT is also suitable for the analysis of linear chirp signals. FrFT can

perform pulse compression, similar to the matched filter, when the transform order matched to the chirp rate of the signal [6].

In this paper, FrFT with pulse inversion is proposed under chirp coded excitation to perform the second harmonic pulse compression. The rest of the paper sections are divided as follows: Section-II provides the background theory and design procedure of the proposed method, Section-III describes the experimental setup and their procedure, the experimental results are presented in Section-IV, and finally the achieved second harmonic pulse compression performance using the FrFT and HMF techniques is discuss in Section-V.

II. THEORY AND DESIGN METHODS

A. FrFT for Second Harmonic Pulse Compression

The FrFT is a generalisation of conventional Fourier transform and can be expressed as [6],

$$\mathcal{F}^\alpha f(x) = \int_{-\infty}^{\infty} B_\alpha(x, y) f(x) dx \quad (1)$$

where, α , is the FrFT transform order and lies in the range of, $\{-2.0 < \alpha < 2.0\}$, and, $B_\alpha(x, y)$, is the *transform kernel* of the FrFT and it is defined as,

$$B_\alpha(x, y) = A_\varphi \exp[j\pi(x^2 \cot \varphi - 2xy \csc \varphi + y^2 \cot \varphi)] \quad (2)$$

where,

$$A_\varphi = (2\pi |\sin \varphi|)^{-\frac{1}{2}} \exp \left[\frac{-j\pi \operatorname{sgn}(\sin \varphi)}{4} + \frac{j\varphi}{2} \right] \quad (3)$$

The FrFT transform order, α , is dependent on the angle of rotation, φ , and it is computed as,

$$\alpha = 2 - \frac{2}{\pi} \varphi \quad (4)$$

For $\alpha = 0$ or 2 , the FrFT is equivalent to the time domain or reverse time domain signal. similarly, for $\alpha = 1$ or -1 , the FrFT is equivalent to the Fourier transform or inverse Fourier transform. However for intermediate values of, α , between, $\{0 \leq \alpha \leq 2\}$, the FrFT lies between the time and frequency domains.

The time-frequency plane representation of linear chirp signal and its rotation with angle, φ , are illustrated in Fig. 1. The angle of rotation, φ , can be calculated as,

$$\varphi = -\tan^{-1} \left[\frac{T}{B} \right] \quad (5)$$

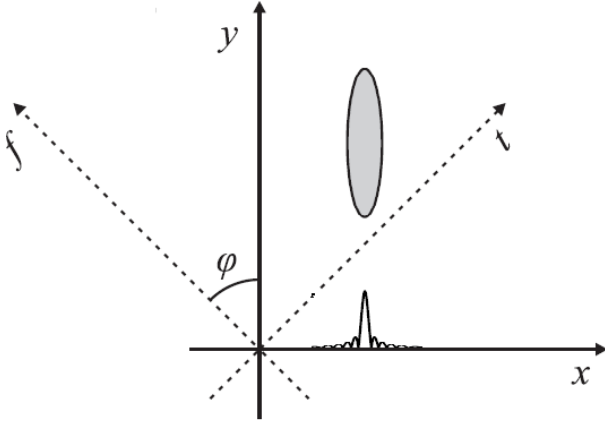

Fig. 1. Illustrates the time-frequency plane representation of linear chirp signal and the rotation of time-frequency plane by angle, φ , using the FrFT technique.

where the minus sign in (5), indicates the rotation of time-frequency plane in counter-clockwise direction. At optimum value of angle, φ , the projection of a rotated time-frequency plane chirp onto the fractional domain shows a maximum compression of chirp signal, as illustrated in Fig. 1.

For discrete signals, the optimum transform order, α_{opt} , related to an optimum value of angle, φ , can be computed as,

$$\alpha_{opt} = 2 + \frac{2}{\pi} \tan^{-1} \left[\frac{T}{B} \frac{f_s^2}{N} \right] \quad (6)$$

where B , is the signal bandwidth, T , is the time duration, f_s , is the sampling rate, and N , is the number of samples in the discrete chirp signal.

In order to compress the SHC of the nonlinear received signal, the α_{opt} , in (6), is computed with twice the chirp-rate of excitation signal.

The direct comparison of the signal in FrFT-domain with the time-domain requires the scaling and offset process in the FrFT-domain signal. Both scaling and offset process are the functions of angle, φ . The scaling of FrFT domain signal can be done by [7],

$$\mu_\alpha = \mu_t \cos(\varphi) \quad (7)$$

where μ_α , and μ_t , are the FrFT domain, and time domain samples respectively. Similarly, the offset between the maximum peaks of the compressed signals in the FrFT-domain and time-domain can be calculated as,

$$M_\alpha = \frac{bN}{f_s} \sin(\varphi) \quad (8)$$

where M_α , is the number of offset samples from the centre of FrFT domain, b is the signal's initial frequency, N is the total number of samples, and f_s is the sampling frequency of the signal.

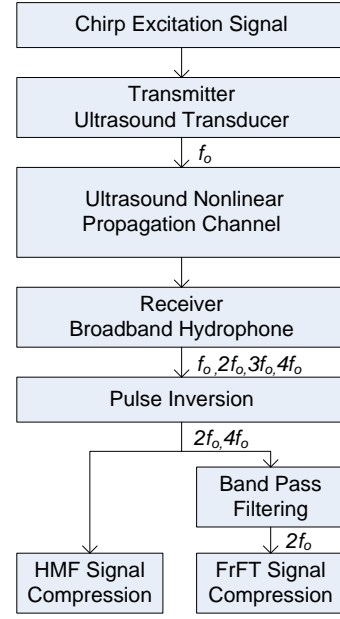

Fig. 2. System flow chart illustrating the signal processing chain for second harmonic pulse compression using the proposed FrFT and a harmonic matched filtering techniques.

B. Matched Filter for Second Harmonic Pulse Compression

In coded excitation systems, long duration signals are used as an excitation to get more energy which results in greater penetration depth. On the receiving side, matched filters, whose impulse response is equal to time-reverse conjugate of the excitation signal, are used to perform pulse compression to recover signal axial resolution.

In this paper, the HMF is used as a reference technique to perform the compression of SHC of the nonlinear received signal. The HMF is designed with twice the instantaneous frequency and bandwidth parameters of excitation signal [8]. Two other variations of HMF technique are also used for comparison. Firstly, the harmonic matched filter with rectangular window (HMF-R), and secondly, the harmonic mismatched filter (HMMF) with an additional Chebyshev window of 100 dB attenuation. This additional window function is used for the further reduction of sidelobes level.

C. Proposed Method

The flow chart of the proposed system for the compression of SHC is shown in Fig. 2. The compression performance of the proposed FrFT is compared with the conventional HMF technique. Linear FM chirp signals are used as an excitation to provide more SNR and penetration depth. A pulse inversion method is proposed here to enhance and extract the SHC under overlap and non-overlap harmonic conditions [9], [10]. The extracted SHC is then compressed using the FrFT and HMF techniques. In case of FrFT compression, bandpass filtering is used after pulse inversion in order to remove the fourth harmonic component, whereas no bandpass filtering is required in case of HMF compression.

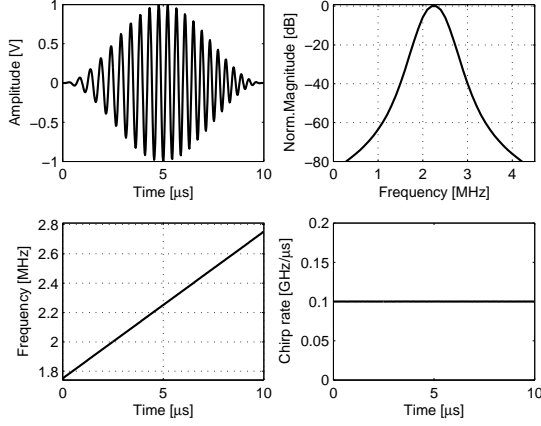

Fig. 3. Illustration of 1 MHz chirp excitation signal (top, left), and associated FFT (top, right), a chirp instantaneous frequency (bottom, left), and a chirp rate of the signal (bottom, right).

TABLE I
DESIGN EXCITATION SIGNAL PARAMETERS

Linear FM Chirp Excitation Signal		
Parameters	Symbol	Value
Sampling Frequency	f_s	40 MHz
Centre Frequency	f_c	2.25 MHz
Bandwidth	B	1 MHz
Time Duration	T	10 μ s
Amplitude	V	150 Vp-p
Tukey Window	W	100 %

III. EXPERIMENTAL INVESTIGATION

A. Designing of Excitation Signal

The linear FM chirp signal, $x(t)$, is designed using an expression as [11],

$$x(t) = v(t) \cdot \exp \left[j2\pi \left(\frac{a}{2}t^2 + bt + c \right) \right], \quad 0 \leq t \leq T \quad (9)$$

where $v(t)$, is the complex envelope, a , is the chirp rate, b , is the initial frequency, and c , is the initial phase of the chirp signal and it is alternating between, 0 and 0.5, for pulse inversion.

The designed chirp signal parameters are shown in Table I. The time-domain chirp signal, and their amplitude spectrum, are shown in Fig. 3 (top, left), and Fig. 3 (top, right), respectively. The linear instantaneous frequency, and constant chirp rate of the excitation signal, are shown in Fig. 3 (bottom, left), and Fig. 3 (bottom, right), respectively.

B. Experimental Setup and Procedure

The proposed method is validated using experiments. The experimental setup for measuring the harmonic components, due to nonlinear propagation of ultrasound waves through the

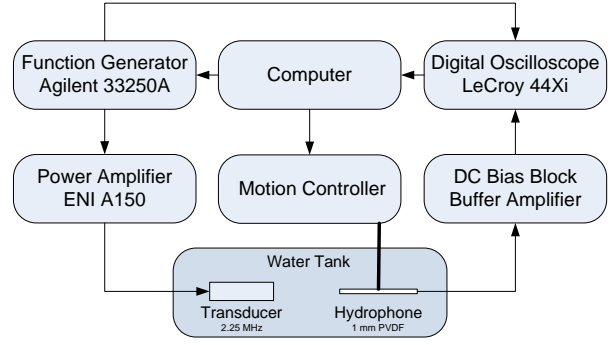

Fig. 4. Schematic diagram of experimental setup.

water, is shown in Fig. 4. All experiments are performed in a tank containing deionised, degassed filtered water. The transducer and hydrophone are mounted in a pitch-catch configuration with a 100 mm distance between them. The alignment between the transducer and hydrophone is set by a custom built motion control system. A programmable function generator (Agilent 33250A, 80 MHz, USA) is set to generate chirp signals. The chirp signals are amplified upto 150 Vpp by an RF power amplifier (ENI A150, gain 55dB, Rochester, NY, USA). The amplified chirp signals are transmitted by a, 56%, fractional bandwidth, 2.25 MHz single element immersion transducer (V323-SM, Panametrics, Waltham, MA, USA). The nonlinear signals are detected by using a needle-type PVDF hydrophone with an active element diameter of 1.0 mm (Precision Acoustics Ltd, Dorchester, UK). The received signals are acquired by using a digital oscilloscope (400-MHz LeCroy, 44Xi, USA) with 32-times averaging. The captured data is stored in a computer and processed offline using MATLAB software (MathWorks Inc., Natick, MA, USA), and the FrFT is computed using the algorithm produced by Ozaktas et al [12].

C. Performance Evaluation of the Second Harmonic Pulse Compression

Three quality parameters namely the mainlobe width (MLW), peak sidelobes level (PSL), and integrated sidelobes level (ISL), are used to quantitatively assessed the performance of second harmonic pulse compression using the FrFT and HMF filtering techniques. In the compressed chirp signal, MLW (or axial resolution) is measured at -20 dB level. The PSL and ISL in decibels are computed as,

$$PSL = 10 \log \left[\frac{\text{peak sidelobes level}}{\text{peak mainlobe level}} \right]$$

and,

$$ISL = 10 \log \left[\frac{\text{total sidelobes energy}}{\text{total mainlobe energy}} \right]$$

IV. EXPERIMENTAL RESULTS AND DISCUSSION

The nonlinear received signals, Rx-1 and Rx-2, and their amplitude spectrum, are shown in Fig. 5 (top, left), and Fig 5

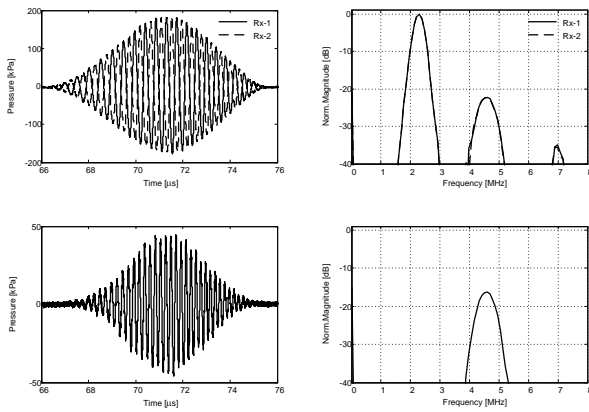

Fig. 5. Illustration of pulse inversion process on experimental data using 1 MHz bandwidth chirp excitation. Received RF-1 and RF-2 signals (top, left) and associated FFT (top, right), and Summation of RF-1 and RF-2 in time (bottom, left) and associated FFT (bottom, right).

TABLE II
PERFORMANCE EVALUATION OF HARMONIC PULSE COMPRESSION

Compressed Signal		FrFT	HMF-R	HMF	HMMF
Parameters	Unit	Value			
MLW	μs	2.306	2.226	2.664	3.031
PSL	dB	-38.10	-24.39	-37.93	-43.40
ISL	dB	-50.69	-24.38	-39.21	-40.23

(top, right), respectively. The signals have the same duration and amplitude spectrum, but a 180° phase difference between them. The resultant time domain signal, after the summation of Rx-1, and Rx-2, is shown in Fig. 5 (bottom, left). The amplitude spectrum of the resultant summed signal, in Fig 5 (bottom, right), clearly shows the enhancement and extraction of the SHC, and the suppression of all odd harmonics including the fundamental frequency component.

The pulse compression of the extracted SHC, using the FrFT and matched filtering techniques, is shown in Fig. 6. The optimum value of the transform order, α_{opt} , is computed using, 6. The second harmonic pulse compression results are shown in Table II. Our results indicate that the FrFT provides, 13.5%, improvement in the MLW when compared with the HMF technique. The MLW in the HMF-R compressed signal is comparable with the FrFT technique, but it provides, 13.7 dB, higher PSL. Compared to FrFT, the HMMF technique provides, 5.3 dB, better PSL, but it degrades the signal MLW by, 24%. This is caused by an additional window function which reduces the signal bandwidth. The PSL provided by FrFT is comparable with the HMF technique.

V. CONCLUSION

In this paper, a method is proposed based on fractional Fourier transform (FrFT) with pulse inversion for the compression of second harmonic component in medical ultrasound harmonic imaging. Linear chirp signals are proposed as an

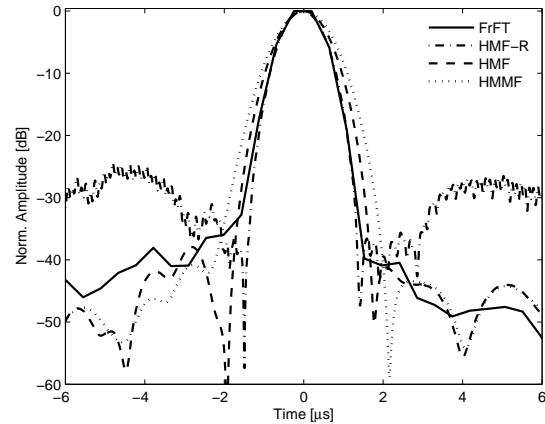

Fig. 6. Comparison of second harmonic pulse compression using FrFT, and matched filtering techniques applied to experimental data using 1 MHz bandwidth chirp excitation.

excitation to provide better SNR and penetration depth. The proposed method is compared with the conventional harmonic matched filtering (HMF) technique. Our results indicate that the FrFT provides, 13.5%, improvement in the mainlobe width with comparable peak sidelobe levels when compared with the HMF technique.

REFERENCES

- [1] J. A. Jensen, "Medical ultrasound imaging," *Progress in Biophysics and Molecular Biology*, vol. 93, no. 1-3, pp. 153 – 165, 2007.
- [2] P. N. T. Wells, "Ultrasound imaging," *Physics in Medicine and Biology*, vol. 51, no. 13, pp. R83–R98, 2006.
- [3] M. Averkiou, "Tissue harmonic imaging," in *Ultrasonics Symposium, 2000 IEEE*, vol. 2, Oct 2000, pp. 1563–1572 vol.2.
- [4] R. S. C. Cobbold, *Foundations of Biomedical Ultrasound*. Oxford University Press, 2007.
- [5] R. Arshadi, A. C. H. Yu, and R. S. C. Cobbold, "Coded excitation methods for ultrasound harmonic imaging," *Canadian Acoustics*, vol. 35, no. 2, pp. 35–46, 2007.
- [6] C. Capus and K. Brown, "Short-time fractional fourier methods for the time-frequency representation of chirp signals," *The Journal of the Acoustical Society of America*, vol. 113, no. 6, pp. 3253–3263, 2003.
- [7] —, "Fractional fourier transform of the gaussian and fractional domain signal support," *Vision, Image and Signal Processing, IEE Proceedings*, vol. 150, no. 2, pp. 99–106, 2003.
- [8] J. Borsboom, C. T. Chin, A. Bouakaz, M. Versluis, and N. de Jong, "Harmonic chirp imaging method for ultrasound contrast agent," *Ultrasonics, Ferroelectrics and Frequency Control, IEEE Transactions on*, vol. 52, no. 2, pp. 241–249, Feb. 2005.
- [9] D. Simpson, C. T. Chin, and P. Burns, "Pulse inversion doppler: a new method for detecting nonlinear echoes from microbubble contrast agents," *Ultrasonics, Ferroelectrics and Frequency Control, IEEE Transactions on*, vol. 46, no. 2, pp. 372–382, Mar 1999.
- [10] Q. Ma, Y. Ma, X. Gong, and D. Zhang, "Improvement of tissue harmonic imaging using the pulse-inversion technique," *Ultrasound in Medicine & Biology*, vol. 31, no. 7, pp. 889 – 894, 2005.
- [11] T. Misaridis and J. Jensen, "Use of modulated excitation signals in medical ultrasound. part ii: design and performance for medical imaging applications," *Ultrasonics, Ferroelectrics and Frequency Control, IEEE Transactions on*, vol. 52, no. 2, pp. 192–207, Feb. 2005.
- [12] H. Ozaktas, Z. Zalevsky, and M. Kutay, *The Fractional Fourier Transform: with Applications in Optics and Signal Processing*. New York: Wiley, 2000.