



Deposited via The University of York.

White Rose Research Online URL for this paper:

<https://eprints.whiterose.ac.uk/id/eprint/220173/>

Version: Accepted Version

Article:

Roy, A., Kanungo, R., Prajapati, D. et al. (2025) Measurement of charge-changing cross section of neutron-rich nitrogen isotopes for determining their proton radii. Nuclear Physics A. 122983. ISSN: 0375-9474

<https://doi.org/10.1016/j.nuclphysa.2024.122983>

Reuse

This article is distributed under the terms of the Creative Commons Attribution (CC BY) licence. This licence allows you to distribute, remix, tweak, and build upon the work, even commercially, as long as you credit the authors for the original work. More information and the full terms of the licence here:

<https://creativecommons.org/licenses/>

Takedown

If you consider content in White Rose Research Online to be in breach of UK law, please notify us by emailing eprints@whiterose.ac.uk including the URL of the record and the reason for the withdrawal request.

Measurement of charge-changing cross section of neutron-rich nitrogen isotopes for determining their proton radii

A. Roy^{a,*}, R. Kanungo^{a,b}, D. Prajapati^a, Y. K. Tanaka^{a,c,d}, S. Bagchi^e, H. Geissel^{e,d}, P. Doornenbal^f, W. Horiuchi^f, D. S. Ahn^f, H. Baba^f, K. Behr^c, F. Browne^f, S. Chen^f, M. L. Cortés^f, A. Estradé^j, N. Fukuda^f, M. Holl^{a,b}, K. Itahashi^f, N. Iwasa^k, W. G. Jiang^{h,i}, S. Kaur^{a,l}, S. Y. Matsumoto^m, S. Momiyamaⁿ, I. Murray^{f,o}, T. Nakamura^p, S. J. Novario^{h,i}, H. J. Ong^q, S. Paschalis^r, A. Prochazka^c, C. Scheidenberger^{c,d}, P. Schrock^s, Y. Shimizu^f, D. Steppenbeck^{f,s}, H. Sakurai^{f,n}, D. Suzuki^f, H. Suzuki^f, M. Takechi^t, H. Takeda^f, S. Takeuchi^p, R. Taniuchi^{n,r}, K. Wimmerⁿ, K. Yoshida^f

^a*Astronomy and Physics Department, Saint Mary's University, Halifax, Nova Scotia B3H 3C3, Canada*

^b*TRIUMF, Vancouver, British Columbia V6T 2A3, Canada*

^c*GSI Helmholtzzentrum für Schwerionenforschung GmbH, D-64291 Darmstadt, Germany*

^d*Justus-Liebig University, 35392 Giessen, Germany*

^e*Department of Physics, Indian Institute of Technology (Indian School of Mines) Dhanbad, Jharkhand - 826004, India*

^f*RIKEN Nishina Center, Wako, Saitama 351-0198, Japan*

^g*Department of Physics, Hokkaido University, Sapporo 060-0810, Japan*

^h*Physics Division, Oak Ridge National Laboratory, Oak Ridge, Tennessee 37831, USA*

ⁱ*Department of Physics and Astronomy, University of Tennessee, Knoxville, Tennessee 37996, USA*

^j*Department of Physics, Central Michigan University, Mount Pleasant, Michigan 48859, USA*

^k*Department of Physics, Tohoku University, Miyagi 980-8577, Japan*

^l*Department of Physics and Atmospheric Science, Dalhousie University, Halifax, Nova Scotia B3H 4R2, Canada*

^m*Department of Physics, Kyoto University, Kyoto 606-8502, Japan*

ⁿ*Department of Physics, University of Tokyo, Bunkyo-ku, Tokyo 113-0033, Japan*

^o*Institut de Physique Nucleaire, IN2P3, CNRS, Université Paris-Sud, Université Paris-Saclay, 91406 Orsay Cedex, France*

^p*Department of Physics, Tokyo Institute of Technology, 2-12-1 O-okayama, Meguro, Tokyo 152-8551, Japan*

^q*RCNP, Osaka University, Mihogaoka, Ibaraki, Osaka 567 0047, Japan*

^r*Department of Physics, University of York, Heslington, York YO10 5DD, United Kingdom*

^s*Center for Nuclear Study, University of Tokyo, RIKEN Campus, Wako, Saitama 351-0198, Japan*

^t*Graduate School of Science and Technology, Niigata University, Niigata 950-2102, Japan*

Abstract

A systematic study of point proton radii along an isotopic chain provides insights into the impact of the extended neutron wavefunction on the protons. This work aims to measure the charge-changing cross section (σ_{cc}) for neutron-rich ^{23}N , marking the first determination of its point proton root mean square radius, as well as the σ_{cc} for $^{21,22}\text{N}$ at beam energies around 250A MeV.

Keywords: Exotic nuclei, Point proton radii, Neutron skin, Magic number

1. Introduction

In exotic nuclei, where the ratio of protons to neutrons is highly asymmetric, unique phenomena such as the formation of halos and neutron skins are observed. Another notable feature of these nuclei is the disappearance of conventional magic numbers, such as $N = 8$ and 20, and the emergence of new magic numbers, such as $N = 14$ and 16, among others. These findings suggest that the nuclear shell structure is significantly modified in the neutron-rich region. The presence of neutron halos in ^{11}Li and ^{11}Be has been linked to the breakdown of the $N = 8$ shell gap [1]. Evidence has also been found for the appearance of a new shell gap at $N = 16$ at the drip line in isotopes from carbon to fluorine [2–8].

*Corresponding author: aritra.roy@smu.ca

For the nitrogen isotope chain, the point proton root mean square radii of $^{17-22}\text{N}$ were recently determined through charge-changing cross sections (σ_{cc}) on a carbon target at approximately 900A MeV by S. Bagchi et al. [9]. A thick neutron skin was reported for $^{19-21}\text{N}$, while a neutron halo-like structure was observed in ^{22}N . The rapid increase in the nuclear matter radii, as observed from ^{22}N (3.07 ± 0.13 fm) to ^{23}N (3.41 ± 0.23 fm) [10], hints towards the halo structure of ^{23}N . A decrease (within uncertainties) in the point proton radii from ^{17}N to ^{21}N was also reported [9], possibly reflecting a transition from deformation toward sphericity at the $N = 14$ shell closure. The notable increase in radius beyond ^{21}N may be attributed to the influence of the $2s_{1/2}$ neutron in ^{22}N . However, even with two neutrons occupying the s -orbital, the observed radius in ^{22}N could not be fully explained [2], while an enlarged core in a *core-plus-n* model is capable of explaining the observed magnitude [11]. Due to the lack of available data on the proton radius of this drip-line nucleus with $N = 16$, this study aims to provide the first determination of the point proton root mean square radius for ^{23}N .

2. Methodology and experimental setup

The measurement of charge-changing cross sections for neutron-rich nitrogen isotopes was conducted using the BigRIPS fragment separator and the Zero Degree Spectrometer (ZDS) at the Radioactive Isotope Beam Factory (RIBF) in Japan [12]. The radioactive ion beams of $^{21-23}\text{N}$ were produced by a high-energy primary beam of ^{48}Ca accelerated to 345A MeV, which interacted with a 10 mm-thick rotating ^9Be target. The isotopes of interest were separated in flight and identified using magnetic rigidity ($B\rho$), time-of-flight (TOF), and energy-loss (ΔE) measurements, i.e., the $TOF - B\rho - \Delta E$ method. Plastic scintillators placed at the F8 and F11 focal planes were used to measure TOF, while trajectory reconstruction was performed using Parallel Plate Avalanche Counter (PPAC) detectors positioned at various focal planes. Multi-Sampling Ionization Chamber (MUSIC) detectors were placed before and after a 2.5 g/cm 2 thick carbon reaction target at the F11 to determine the atomic number (Z) of the particles. A schematic view of the experimental setup, including these detectors, is shown in Fig. 1.

The charge-changing cross-section (σ_{cc}) for reactions that alter the proton number of the projectile nucleus was determined using the transmission method on a carbon target. The number of incident nuclei (N_{in}) was identified and counted based on their total mass and proton number (AZ) on an event-by-event basis before the reaction occurs. Nuclei that pass through the reaction target at F11 with charge greater than or equal to the proton number of the incident beam ($N_{out \geq Z_{in}}$) are identified and counted. The charge-changing cross-section is then obtained from the relation $\sigma_{cc} = -\frac{1}{t} \ln \frac{N_{out \geq Z_{in}}}{N_{in}}$, where t is the thickness of the reaction target.

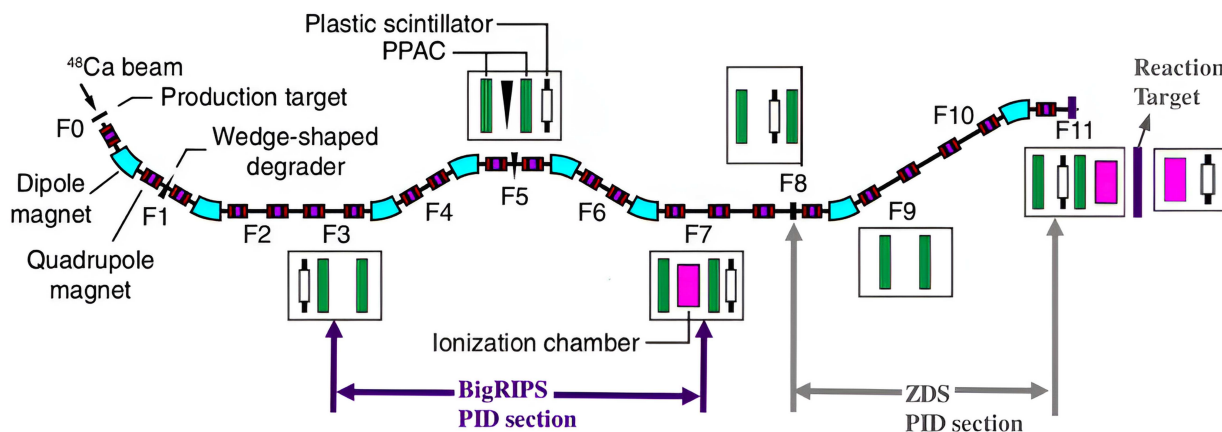

Figure 1: Schematic view of experimental setup [13].

It is important to note that nuclear reactions may occur in non-target materials within the beamline. To account for this, measurements are taken without the reaction target. Thus, the charge-changing cross-section is measured by $\sigma_{cc} = \frac{1}{t} \ln \frac{R_{T_{out}}}{R_{T_{in}}}$, where the transmission ratio with the reaction target is expressed as $R_{T_{in}} = \frac{N_{out \geq Z_{in}}}{N_{in}}$, while $R_{T_{out}}$ denotes

the transmission ratio without the reaction target. The main advantage of this method is that it involves event-by-event counting of the selected incident beam, thereby eliminating uncertainty in selecting the incident particles (N_{in}) of the desired isotope.

3. Results and discussion

As shown in the particle identification plot Fig. 2a, the ^{23}N isotope is well separated from other nuclear species before the reaction target and have a count rate of 260 pps at the final focal plane F11. Exotic nuclei $^{20,22}\text{C}$ and ^{22}N are also present in the PID plot. A similar particle identification plot is generated for the ^{21}N isotope, with a count rate of 290 pps at the final focal plane F11. The secondary beam energy of the exotic nitrogen isotopes at the reaction target location is around 250A MeV.

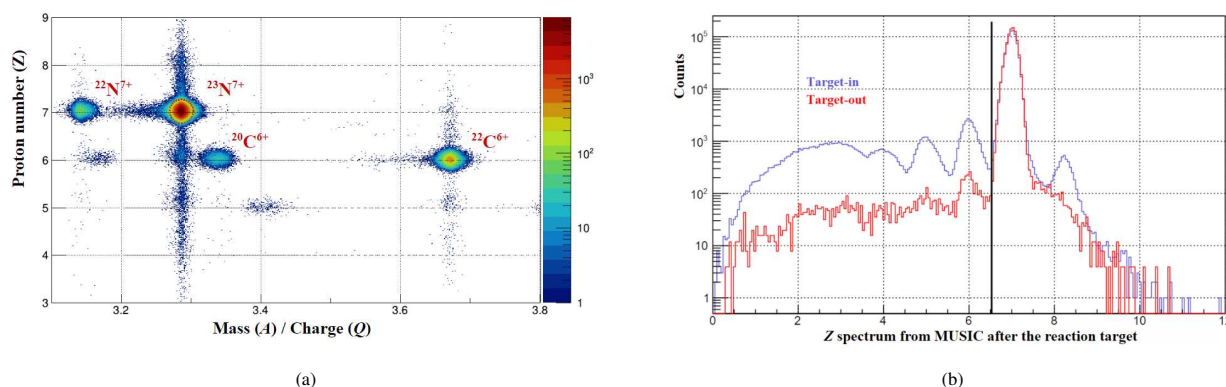

Figure 2: (a) Particle IDentification plot for ^{23}N at F11 before target. (b) Z spectrum after the reaction target with ^{23}N incident beam selection for target-in (blue) and target-out (red) setup.

Fig. 2b shows the Z-spectrum for outgoing particles obtained from the energy loss information in the MUSIC detector placed after the reaction target at F11. The charge-changing reactions are significantly increased in the spectrum with the reaction target compared to the spectrum without the reaction target. The analysis is ongoing to derive the measured charge changing cross section, investigating the constant transmission over the phase space. The finite-range Glauber model will be used to extract the root mean square point proton radii from the measured cross sections.

Acknowledgements

The authors extend their sincere appreciation to the RIKEN Radioactive Isotope Beam Factory for supplying the ^{48}Ca beam at remarkably high intensity. We also acknowledge the valuable support received from NSERC Canada.

References

- [1] I. Tanihata et al., *Recent experimental progress in nuclear halo structure studies*, Progress in Particle and Nuclear Physics, vol. 68, pp. 215–313, 2013.
- [2] A. Ozawa et al., *New Magic Number, $N = 16$, near the Neutron Drip Line*, Phys. Rev. Lett., vol. 84, no. 24, pp. 5493–5495, Jun. 2000.
- [3] M. Bellegruic et al., *In-beam γ -spectroscopy using projectile fragmentation: Structure of neutron-rich nuclei around $N=20$* , Nuclear Physics A, vol. 682, no. 1, pp. 136–142, 2001.
- [4] A. Schiller et al., *Selective Population and Neutron Decay of an Excited State of ^{23}O* , Phys. Rev. Lett., vol. 99, no. 11, pp. 112501, 2007.
- [5] C. R. Hoffman et al., *Evidence for a doubly magic ^{24}O* , Phys. Lett. B, vol. 672, no. 1, pp. 17–21, 2009.
- [6] R. Kanungo et al., *One-Neutron Removal Measurement Reveals ^{24}O as a New Doubly Magic Nucleus*, Phys. Rev. Lett., vol. 102, no. 15, p. 152501, Apr. 2009.
- [7] Y. F. Geng et al., *Excitation spectra of the heaviest carbon isotopes investigated within the CD-Bonn Gamow shell model*, Phys. Rev. C, vol. 106, no. 2, p. 024304, Aug. 2022.

- [8] S. Kaur et al., *Proton distribution radii of $^{16-24}\text{O}$: Signatures of new shell closures and neutron skin*, Phys. Rev. Lett., vol. 129, no. 14, pp. 142502, Sep. 2022.
- [9] S. Bagchi et al., *Neutron skin and signature of the $N = 14$ shell gap found from measured proton radii of $^{17-22}\text{N}$* , Physics Letters B, vol. 790, pp. 251–256, 2019.
- [10] A. Ozawa et al., *Measurements of interaction cross sections for light neutron-rich nuclei at relativistic energies and determination of effective matter radii*, Nuclear Physics A, vol. 691, no. 3, pp. 599–617, 2001.
- [11] R. Kanungo et al., *Possibility of enlarged core structure of $N=15$ neutron-rich nuclei*, Physics Letters B, vol. 512, no. 3, pp. 261–267, 2001.
- [12] Y. Yano et al., *The RIKEN RI Beam Factory Project: A status report*, Nuclear Instruments and Methods in Physics Research Section B: Beam Interactions with Materials and Atoms, vol. 261, no. 1, pp. 1009–1013, 2007.
- [13] S. Bagchi et al., *Two-Neutron Halo is Unveiled in ^{29}F* , Phys. Rev. Lett., vol. 124, no. 22, pp. 222504, 2020.