



Deposited via The University of Sheffield.

White Rose Research Online URL for this paper:

<https://eprints.whiterose.ac.uk/id/eprint/209037/>

Version: Accepted Version

---

**Article:**

Xu, D., Ricco, P. and Duan, L. (2024) Görtler instability and transition in compressible flows. *AIAA Journal*, 62 (2). pp. 1-29. ISSN: 0001-1452

<https://doi.org/10.2514/1.j062866>

---

© 2023 by the American Institute of Aeronautics and Astronautics, Inc. All rights reserved. This is an author-produced version of a paper subsequently published in *AIAA Journal*. Uploaded in accordance with the publisher's self-archiving policy.

**Reuse**

Items deposited in White Rose Research Online are protected by copyright, with all rights reserved unless indicated otherwise. They may be downloaded and/or printed for private study, or other acts as permitted by national copyright laws. The publisher or other rights holders may allow further reproduction and re-use of the full text version. This is indicated by the licence information on the White Rose Research Online record for the item.

**Takedown**

If you consider content in White Rose Research Online to be in breach of UK law, please notify us by emailing [eprints@whiterose.ac.uk](mailto:eprints@whiterose.ac.uk) including the URL of the record and the reason for the withdrawal request.

# Görtler instability and transition in compressible flows

Dongdong Xu\*, Pierre Ricco†

*The University of Sheffield, Sheffield, S1 3JD, United Kingdom*

Lian Duan‡

*The Ohio State University, Columbus, Ohio 43210*

[Xu, D. Ricco, P. Duan, L. “Görtler instability and transition in compressible flows”, AIAA J., 62, 2, pp. 489-517 \(2024\)](#)

We present a discussion on theoretical, experimental and computational research studies on Görtler instability and the related transition to turbulence occurring in compressible boundary layers over concave surfaces. We first examine the theoretical results on primary and secondary instabilities, emphasizing the role of receptivity, the mechanism by which external agents, such as free-stream fluctuations or wall roughness, act on a boundary layer to trigger Görtler vortices. We review experimental findings obtained from measurements in supersonic and hypersonic wind tunnels, and discuss studies employing numerical methods, focusing on the direct numerical simulation approach. The research in these two last sections is surveyed according to the geometrical configuration, from simple concave walls to more complex surfaces of hypersonic vehicles. The experimental investigations have been successful in the visualizations of Görtler vortices, in the measurement of the wall-heat transfer in the transitional region and in the computation of the Görtler-vortex growth rates, although detailed boundary-layer velocity measurements are still missing. Direct numerical simulations have confirmed instability results emerging from stability theories and revealed nonlinear interactions between Görtler vortices and other disturbances. The established initial-boundary-value receptivity theory can certainly benefit from more advanced experimental measurements, and receptivity results should be used in combination with direct numerical simulations. A major conclusion of our review is therefore that the understanding of Görtler vortices should be pursued by a combined methodology including theoretical analysis based on the receptivity formalism, direct numerical simulation and experiments. Highly desirable outcomes of such endeavor are the prediction of the location and extension of the transition region, and a model for the transition process. We finally highlight further prospects and challenges on fundamental and applied research on Görtler instability and transition in compressible flows.

## Nomenclature

$c_\infty^*$	=	free-stream speed of sound
$G_\theta$	=	local Görtler number
$G_\Lambda$	=	global Görtler number
$J$	=	angular momentum
$\mathcal{L}, \mathcal{L}', \mathcal{M}$	=	differential operators
$M_\infty$	=	free-stream Mach number
$N$	=	integral of the growth rate
$\mathcal{N}$	=	nonlinear terms
$\mathcal{P}, P, p, p_{mean}, p', \hat{p}(y)$	=	pressures
$P_0^*$	=	stagnation pressure
$\mathbf{q} = \{u, v, w, p, \tau\}$	=	flow quantity vector

---

\*Research Associate, Department of Mechanical Engineering, Sir Frederick Mappin Building, Mappin Street, Sheffield, United Kingdom.

†Professor, Department of Mechanical Engineering, Sir Frederick Mappin Building, Mappin Street, Sheffield, United Kingdom. Corresponding author.  
Email: p.ricco@sheffield.ac.uk.

‡Associate Professor, Department of Mechanical and Aerospace Engineering, 201 W. 19th Avenue, Columbus, Ohio 43210.

$\mathbf{Q} = \{U, V, W, P, T\}$	= base-flow quantity vector
$\mathbf{q}' = \{u', v', w', p', \tau'\}(\mathbf{x}, t)$	= disturbance vector
$\hat{\mathbf{q}} = \{\hat{u}, \hat{v}, \hat{w}, \hat{p}, \hat{\tau}\}(y)$	= disturbance shape function vector
$r$	= radial coordinate
$r_0^*$	= radius of curvature
$Re$	= Reynolds number based on the displacement thickness
$R_\Lambda$	= Reynolds number based on the characteristic spanwise length scale
$R_\infty^*$	= unit Reynolds number
$r_t$	= turbulent Reynolds number
$St$	= Stanton number
$t$	= time
$Tu$	= turbulence level
$T(y; x)$	= base-flow temperature
$T_0^*$	= stagnation temperature
$\tau'(\mathbf{x}, t)$	= disturbance temperature
$U_\phi$	= azimuthal velocity
$U_\infty^*$	= free-stream mean velocity
$U(y; x)$	= base-flow streamwise velocity
$u(\mathbf{x}, t)$	= streamwise velocity
$u'(\mathbf{x}, t)$	= streamwise disturbance velocity
$\hat{u}(y)$	= streamwise velocity shape function
$V(y; x)$	= base-flow wall-normal velocity
$v(\mathbf{x}, t)$	= wall-normal velocity
$v'(\mathbf{x}, t)$	= wall-normal disturbance velocity
$\hat{v}(y)$	= wall-normal velocity shape function
$W(y; x)$	= base-flow spanwise velocity
$w(\mathbf{x}, t)$	= spanwise velocity
$w'(\mathbf{x}, t)$	= spanwise disturbance velocity
$\hat{w}(y)$	= spanwise velocity shape function
$\mathbf{x} = \{x, y, z\}$	= orthogonal curvilinear coordinate system
$x$	= streamwise coordinate
$x_c$	= neutral point of stability
$x_T$	= location where transition occurs
$\hat{x}$	= slowly varying streamwise variable
$y$	= wall-normal coordinate
$z$	= spanwise coordinate
$\alpha$	= streamwise wavenumber
$-\alpha_i$	= growth rate
$\beta$	= spanwise wavenumber
$\delta r$	= change in radial distance
$\epsilon$	= amplitude of perturbation
$\epsilon_s$	= small parameter
$\theta^*$	= boundary-layer momentum thickness
$\Lambda^*$	= characteristic spanwise length scale
$\nu_\infty^*$	= free-stream kinematic viscosity
$\rho$	= density
$\rho_0$	= base-flow density
$\tau$	= temperature
$\phi$	= azimuthal angle
$\omega$	= frequency
Superscripts	
*	= dimensional quantities

/ = disturbance quantities  
† = complex conjugate

## I. Introduction

THE transition of boundary layers from the laminar to the turbulent regime is one of the most challenging topics in classical physics and applied mathematics, and stands as a bottleneck problem in modern flow engineering technology. Major issues are the undesired increase of wall friction and wall-heat transfer when the flow becomes turbulent, which impacts directly on the performance of vehicles and on the efficiency of machinery because of the energy losses in boundary layers. Compressibility, as a result of velocities comparable or larger than the speed of sound, seriously complicates matters as the energy losses are intensified, the surface may suffer from damage due to the induced stresses and heat, and aeroacoustic noise production affects wind-tunnel experiments and high-speed flight performance [1]. In some cases, wall turbulence is instead desirable, for example to enhance mixture and combustion in scramjet engines and to avoid aerodynamic losses and excessive dissociation of oxygen and nitrogen in air streams [2]. Understanding transition in compressible wall-bounded flows is therefore central for the design of supersonic air-breathing vehicles, hypersonic space re-entry capsules, jet engines, and hypersonic wind tunnels [3, 4].

Compressibility leads to scenarios of instability that are more complex than in the incompressible regime [5]. Second Mack modes [6] and radiating secondary instability modes [7, 8] only exist in the supersonic regime. Receptivity, i.e., the mechanism by which extraneous perturbations enter the boundary layer to excite instability waves, is also much more involved in the compressible regime. In addition to free-stream vortical disturbances and surface roughness, extra agents responsible for triggering instability modes in compressible boundary layers include impinging shock waves, free-stream temperature disturbances, sound produced by nearby wall turbulence and surface ablation, all of which are absent in the incompressible regime.

Compressible boundary layers are strongly affected by the concave curvature of boundary-layer streamlines in both open and confined configurations [9, 10]. The wall concavity creates an imbalance between the centrifugal force and the wall-normal pressure gradient, which leads to Görtler vortices [11, 12]. These vortices occur in transitional boundary layers and have also been observed in turbulent boundary layers [13, 14]. They are steady or low-frequency streamwise elongated structures, whose formation, evolution and stability are extremely sensitive to the disturbance environment, i.e., these disturbances can be thoroughly explored and comprehended via a receptivity formalism [15, 16].

Compressible Görtler vortices are a major concern for the design of hypersonic vehicles and atmospheric re-entry capsules because transition is hastened by their presence. These vortices can produce a significant increase of the wall-heat transfer, thus imposing severe constraints on the thermal protection system. The efficiency of hypersonic vehicles increases when inward turning inlets are employed, as in the HyCause flight test program and in the Falcon program [17], but these inlets involve concave surfaces and therefore Görtler instability can become a serious concern for their design.

Another challenge posed by flows dominated by Görtler vortices is the design of nozzles in supersonic wind tunnels [4, 18, 19]. The central design objective is to maintain the free stream as quiet and uniform as possible and the operating pressures as high as possible in order to reproduce flight conditions in the tunnel test section. In these ‘quiet’ conditions, an objective is also to collect experimental data of sufficiently high quality to attain meaningful comparison with theoretical results. It is therefore imperative to preserve laminar boundary layers over as much wind-tunnel surface as possible because turbulent boundary layers are an undesired source of intense aeroacoustic noise that prevents accurate measurements in the test section. In supersonic conditions, concave side walls are used to create the required nozzle expansion. Görtler instability is therefore a serious design concern and must be suppressed over the nozzle walls to delay transition to turbulence.

Görtler vortices may also dominate the highly-curved pressure sides of turbine and compressor blades [10]. Transonic conditions, highly-disturbed environments and wall cooling render the study of Görtler instability in turbomachinery boundary layers a major challenge. The design of jet engines for improved efficiency requires a full understanding of these flows.

Motivated by all these pressing fluids engineering problems, we present herein an overview of the state-of-the-art knowledge on Görtler vortices in compressible transitional boundary layers, discussing theoretical, experimental and numerical results. Reviews on Görtler instability have appeared in the literature, but they mostly focused on the incompressible regime and date back to about thirty years ago or more, e.g., Hall [20], Floryan [14] and Saric [21]. In those past surveys, limited discussion was devoted to the receptivity of boundary layers to external disturbances, such as free-stream turbulence or wall roughness. Receptivity theory is instead central in our presentation because it is a key ingredient in the formation and evolution of Görtler vortices. Our review focuses on these vortical structures from their inception through their nonlinear evolution, secondary instability and finally to the laminar-turbulent transition, thus excluding Görtler-like structures occurring in fully developed

turbulent flows. We finally note that our review is the first on Görtler instability in the compressible regime.

The review is divided in three main sections. Theoretical results are discussed in §II. Asymptotic and perturbation techniques, combined with numerical computations, have been the main theoretical method of choice for the study of compressible flows dominated by Görtler vortices. Experimental findings, mainly from measurements in supersonic and hypersonic wind tunnels, are presented in §III. Numerical results, mostly from direct numerical simulations (DNS), are reviewed in §IV. The experimental and numerical sections are organized according to the geometrical configuration and the subsections are ordered according to the complexity of the geometry. An overview of future prospects and challenges is contained in §V. Appendix A discusses the fundamental physical mechanism behind Görtler instability.

## II. Theoretical studies

We first present the fundamental features of Görtler instability and then discuss the three main theoretical frameworks: the local eigenvalue approach, the initial-value approach without free-stream disturbances, and the receptivity theory, i.e., the initial-boundary-value approach where free-stream disturbances are included in the formulation. These frameworks are listed in table 1. Results on secondary instability and flow control are also reviewed. We utilize the term ‘theoretical’ to define studies in which the compressible Navier-Stokes equations are not solved in their entirety, but they are simplified by neglecting terms that are deemed negligible in the overall dynamics. Given the complexity of the problem, numerical computations have nevertheless been used to solve these stability and receptivity equations.

**Table 1 Schematic of theoretical frameworks for the study of Görtler instability. LPSE and NPSE stand for linear and nonlinear parabolized stability equations. BRE denotes the boundary-region equations, while LBRE indicates the linear BRE. LNS stands for the linear Navier-Stokes equations and FSD stands for free-stream disturbances.**

Theories	Local eigenvalue approach	Initial-value approach without FSD	Receptivity theory
Linear	Görtler modes	LPSE, homogeneous LBRE	LBRE system, LNS
Nonlinear	—	Weakly nonlinear theory, NPSE	nonlinear BRE system, DNS

### A. Fundamentals of Görtler instability

The fundamental mechanism behind the formation of Görtler vortices is the centrifugal instability, i.e., a laminar boundary layer becomes unstable because of the concave curvature of the flow streamlines. It occurs at all Mach numbers, from the incompressible regime to the hypersonic regime. The physical and mathematical features of this mechanism are described in Saric [21], who refers to the earlier studies by Rayleigh [22], based on the change of kinetic energy of ‘revolving’ fluids, and by von Kármán [23], based on a pressure-imbalance argument. Görtler instability in free-stream boundary layers flowing over streamwise concave surfaces occurs because of the imbalance between the centrifugal effect and a pressure difference. The boundary layer is unstable as the wall-normal gradient of the pressure disturbance, required to guarantee stability, is typically small in these high-Reynolds-number boundary layers because of their small thickness. Moving across the boundary layer towards the concave wall, the radial distance increases only slightly, whereas the streamwise velocity drops significantly from its free-stream value, vanishing at the wall because of the no-slip condition. The square of the angular momentum is thus a rapidly decreasing function of the radial coordinate, which, according to the Rayleigh circulation criterion [22], renders the fluid inviscidly unstable. Appendix A discusses the centrifugal instability mechanism in further detail.

The centrifugal instability in a boundary layer was studied for the first time by Görtler [11] in the incompressible regime. Görtler [11] identified streamwise-oriented, counter-rotating vortices as the main feature of the flow, similar to those observed in Taylor-Couette flows [26]. Görtler vortices may significantly distort the base-flow velocity profile and saturate to a nearly constant amplitude, featuring distinct mushroom-shaped structures of the streamwise velocity, as shown in figure 1. Secondary instability acts to disrupt the saturated Görtler vortices and readily leads the flow to transition to turbulence. All these features have been observed in the incompressible and compressible regimes.

Two distinct Görtler numbers are commonly employed to study Görtler instability. The first is the local Görtler number, defined by Görtler [11] as

$$G_\theta = \frac{U_\infty^* \theta^*}{\nu_\infty^*} \sqrt{\frac{\theta^*}{r_0^*}}, \quad (1)$$

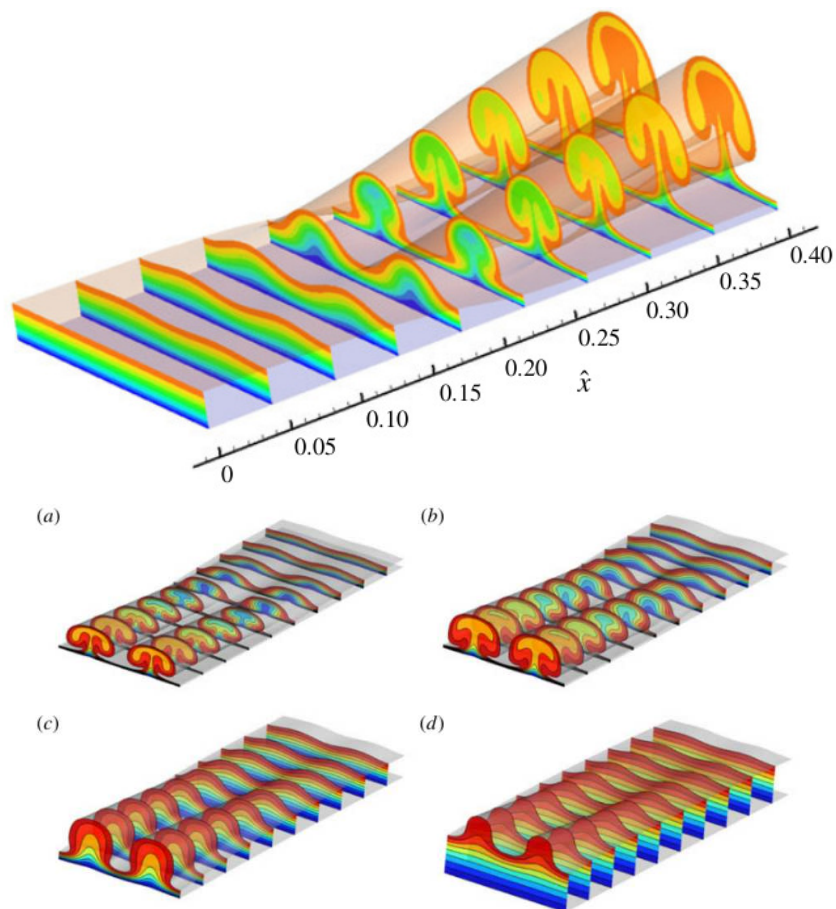

**Fig. 1** Numerical visualizations of mushroom structures of Görtler vortices. Top:  $M_\infty = 0$ . Bottom: from (a) to (d),  $M_\infty = 1.5, 3, 4.5, 6$ . Taken from Xu et al. [24] and Ren and Fu [25], respectively, with permission from Cambridge University Press (CUP).

where  $U_\infty^*$  is the free-stream velocity,  $\nu_\infty^*$  is the free-stream kinematic viscosity of the fluid,  $\theta^*$  is the boundary-layer momentum thickness, and  $r_0^*$  is the radius of curvature of the surface over which the boundary layer evolves (henceforth, the asterisk \* denotes dimensional quantities, while non-dimensional quantities are not marked by any symbol). The second is the global Görtler number, first defined by Wu et al. [15] as

$$G_\Lambda = \left( \frac{U_\infty^* \Lambda^*}{\nu_\infty^*} \right)^2 \frac{\Lambda^*}{r_0^*}, \quad (2)$$

where  $\Lambda^*$  is a representative spanwise length scale. Wu et al. [15] realized that it was necessary to introduce the global Görtler number  $G_\Lambda$  to study the excitation and downstream development of Görtler vortices. Although a local instability exists and it can be characterized by the local Görtler number  $G_\theta$ , the global Görtler number  $G_\Lambda$  is necessary because these vortices evolve over a very large scale along the streamwise direction, which cannot be described by  $G_\theta$ . The development of Görtler vortices can be characterized by  $G_\Lambda$  because  $G_\Lambda$  remains constant as the spanwise length scale of the vortices is fixed, while  $G_\theta$  varies as the boundary-layer thickness grows. In the limit of high Reynolds number, small perturbations and a radius of surface curvature much larger than the boundary-layer thickness (i.e.,  $r_0^* \gg \theta^*$ ), the Görtler number appears in the linearized equations, while the leading-order base-flow boundary layer is unaffected by the wall curvature.

The other non-dimensional parameter used in the study of compressible Görtler vortices is the Mach number based on  $U_\infty^*$  and the speed of sound in the free stream,  $c_\infty^*$ ,

$$M_\infty = \frac{U_\infty^*}{c_\infty^*}. \quad (3)$$

Compressible Görtler instability has been studied up to the hypersonic regime, i.e., for Mach numbers exceeding 5.

## B. Local eigenvalue approach

Following Görtler [11], linear stability theory (LST) was the first method to be adopted to study compressible Görtler instability. At any Mach number, the central assumption behind LST is that the flow perturbation is much smaller than the laminar base flow so that the equations of motion can be linearized. The second assumption is that the base flow is parallel, i.e., its wall-normal velocity is neglected, its streamwise velocity and temperature depend on the wall-normal direction, while their dependence on the streamwise direction is included parametrically in the formulation. The velocity, pressure and temperature  $\mathbf{q} = \{u, v, w, p, \tau\}$  are decomposed into the base-flow velocity, pressure and temperature  $\mathbf{Q} = \{U(y; x), 0, 0, P(x), T(y; x)\}$  and the perturbation  $\mathbf{q}'$  as

$$\mathbf{q} = \{U(y; x), 0, 0, P(x), T(y; x)\} + \epsilon \mathbf{q}'(\mathbf{x}, t), \quad (4)$$

where  $\epsilon \ll 1$  is the amplitude of the perturbation and  $\mathbf{x} = (x, y, z)$  is the orthogonal curvilinear coordinate system defining the streamwise, wall-normal and spanwise directions. As the boundary-layer approximation is often adopted, the base-flow pressure  $P(x)$  is, at first order, independent of the wall-normal direction and a known function of the streamwise direction. In the quasi-parallel-flow approach, the base-flow wall-normal velocity  $V(y; x)$  is retained, while the base-flow dependence on the streamwise direction is taken to be parametric. It must be noted, however, that the nonparallel-flow effects are not fully accounted for because, although  $V(y; x)$  is included in the formalism, i) the terms involving the partial derivatives of  $U$  and  $V$  with respect to  $x$  are neglected in the equations of motion and ii) the  $x$ -dependence of the disturbance is not considered fully because it is expressed in exponential form.

Modal solutions for the perturbation are sought as

$$\mathbf{q}' = \hat{\mathbf{q}}(y) e^{i(\alpha x + \beta z - \omega t)} + \text{c.c.}, \quad (5)$$

where c.c. indicates the complex conjugate and  $\alpha$ ,  $\beta$ ,  $\omega$  are the streamwise wavenumber, the spanwise wavenumber and the frequency, respectively. Substituting the flow decomposition (4) and expression (5) into the compressible Navier-Stokes equations and neglecting the nonlinear terms yield the compressible linear stability equations,

$$\mathcal{L}[\hat{\mathbf{q}}] = 0. \quad (6)$$

The eigenvalue problem is described by the linear system (6), supplemented by homogeneous boundary conditions, i.e., the

velocity components are null at the wall because of the no-slip condition, the temperature is null at the wall in isothermal conditions or its wall-normal gradient at the wall is null in adiabatic conditions, while all the perturbation components vanish in the free stream. The choice of a complex frequency  $\omega$  and real wavenumbers  $\alpha$  and  $\beta$  leads to the temporal instability problem because the instability manifests itself as a growth in time (the imaginary part of  $\omega$  is positive). If a complex  $\alpha$ , real  $\omega$  and real  $\beta$  are chosen, the spatial instability problem is instead considered. Spatial instability is found when the imaginary part of  $\alpha$  is negative.

Aihara [27] first studied the temporal compressible Görtler instability by the parallel-flow LST, thus extending the incompressible-regime study of Görtler [11]. Aihara [27] assumed the dynamic viscosity and the thermal conductivity to be constant and found that compressibility is destabilizing. Hammerlin [28] studied the  $M_\infty \ll 1$  case and included a temperature-dependent viscosity, showing that, differently from Aihara [27], compressibility is stabilizing. Kobayashi and Kohama [29] resolved this controversy by adopting Sutherland’s viscosity law and concluded that the boundary layer becomes more stable as the Mach number increases, as in Hammerlin [28], thus confirming the importance of modelling the viscosity as a temperature-dependent quantity. Kahawita and Meroney [30] studied the effect of wall heating on the temporal growth by invoking the parallel-flow assumption, while Kahawita and Meroney [31] studied how wall heating and wall suction affect the spatial growth of the Görtler vortices by including the wall-normal base-flow velocity in their framework. Wall suction was found to be stabilizing, while wall heating was stabilizing on disturbances with large spanwise wavelength and destabilizing on disturbances with small spanwise wavelength, as for compressible Klebanoff modes over flat plates [32, 33]. It is worth mentioning that, in the studies of Kahawita and Meroney [30, 31], the buoyancy effects were included and the temperature gradients were implicitly assumed small enough not to alter the fluid density.

For  $M_\infty = O(1)$ , El-Hady and Verma [34], El-Hady and Verma [35], Goglia and Verma [36], El-Hady and Verma [37] and El-Hady and Verma [38] studied the steady spatial growth of compressible Görtler vortices, extending the incompressible study of Floryan and Saric [39]. The wall-normal base-flow velocity and the streamwise derivatives of the base flow were retained in the formulation. Their numerical procedure reduced the partial differential system to a set of ordinary differential equations by adopting a quasi-parallel-flow approximation because the streamwise evolution of the Görtler vortices was not treated explicitly in their computations. They reported that compressibility stabilizes the growth rate, in agreement with Hammerlin [28] and Kobayashi and Kohama [29]. Wall suction was also found to be stabilizing, although it becomes less influential as the Mach number increases. El-Hady and Verma [34] showed that, at  $M_\infty = 3$ , mild cooling is destabilizing and intense cooling is stabilizing for disturbances with large spanwise wavelengths, while disturbances with small spanwise wavelengths are always destabilized by cooling, results that clash with those of Kahawita and Meroney [31]. Malik [40] utilized linear Görtler instability results to predict the transition location over nozzles in supersonic wind tunnels using the  $e^N$  method and suggested that  $N = 10$  is a sound choice for the prediction of transition triggered by Görtler vortices.

Ren and Fu [41, 42, 43] investigated multiple linear compressible Görtler modes, revealing the likely competition between the wall-layer mode and the adjustment-layer mode as the Görtler number and the wavenumber changed, as discussed further in §II.C.1. As in Ren and Fu [44], the adjustment-layer mode was found to be dominant for moderate Görtler numbers, while, for larger Görtler numbers, the wall-layer mode become the most dangerous one. Ren and Fu [41] also discovered that the first Görtler mode is the most unstable one, while higher modes are progressively less unstable, in line with the results of Wu et al. [15] for the incompressible case.

### C. Initial-value approach without free-stream disturbances

In all the research studies discussed in §II.B, it is evident that there was no consensus on how to treat the nonparallel-flow effects in a consistent manner. This problem was resolved when Hall [12, 45] first pointed out that, in the incompressible regime, the nonparallel-flow terms cannot be neglected or included in an approximate manner in the study of Görtler instability. This result emerged from realizing that the nonparallel-flow terms crucially dictate the streamwise evolution and growth of the boundary layer for Görtler number of order one, the spanwise wavelength comparable with the boundary-layer thickness, and in the limits of large Reynolds number and large radius of surface curvature. Hall [12, 45] also showed that the asymptotic limit of large Reynolds number renders the Navier-Stokes equations parabolized along the streamwise direction, i.e., the streamwise diffusion and the streamwise pressure gradient of the perturbations are neglected because they are asymptotically small. In the most general case, the spanwise diffusion is retained because the spanwise wavelength of the disturbance is comparable with the boundary-layer thickness. The curvature effects are distilled into the Görtler number because of the additional limit of radius of curvature asymptotically larger than the boundary-layer thickness. These (steady or low-frequency) parabolized Navier-Stokes equations are also known as the boundary-region equations [15, 46–48]. We adopt this terminology herein, although it was not utilized by Hall and coworkers. Since the differential system is parabolic, a central role in the dynamics of

the Görtler vortices is played by the initial upstream conditions, from which the downstream-marching computation is started near the leading edge, by the wall boundary conditions, and by the outer free-stream boundary conditions at a large wall-normal distance. It was therefore pointed out by Hall [12, 45] that the only valid methodology to study Görtler instability was to include the influence of external disturbing agents on the boundary-layer dynamics, such as free-stream disturbances and/or wall roughness, which uniquely determine the initial and boundary conditions. The concept of unique neutral curve, obtained via the linear eigenvalue stability analysis, is not tenable because of the influence of the initial and free-stream boundary conditions. The same arguments are valid in the compressible regime [49, 50]. Hall and Fu [50] concluded that previous studies on compressible Görtler instability, where the streamwise evolution and nonparallelism had been ignored or modelled in some ad-hoc fashion, such as those discussed in §II.B, were not valid. Hall [12] and Hall and Malik [49] also proved that the eigenvalue approach is only appropriate in the limits of large spanwise wavenumber and large Görtler number.

In §II.C.1, we discuss results of compressible Görtler instability based on the boundary-region equations. In §II.C.2, we present results emerging from the solutions of the parabolized stability equations, where the streamwise diffusion and the streamwise pressure gradient are modelled. In all the studies discussed in §II.C.1 and §II.C.2, the disturbances were required to vanish in the free stream, i.e., it was assumed that the perturbations were wholly confined within the boundary layer. The effect of the free-stream perturbations on Görtler instability was thus not taken into account.

### 1. Boundary-region equations

Hall and Malik [49, 51] were the first to take into account the nonparallel-flow effects in a self-consistent manner in the study of compressible Görtler vortices. They focused on disturbances with wavelengths that were much smaller than the boundary-layer thickness. For this asymptotic limit, the parabolic partial differential system reduces to a sequence of linear equations, whose solvability conditions allow computing the asymptotic growth rate more quickly than when using the parallel-flow eigenvalue approach or when solving the full parabolic system. They concluded that compressibility has a stabilizing effect on Görtler instability, a finding that is qualitatively consistent with the results based on the parallel-flow assumption, discussed in §II.B. Dando [52] extended the study of Hall and Malik [49] to include the influence of cross flow.

Spall and Malik [53] numerically solved the steady boundary-region equations to study the linear evolution of compressible Görtler vortices. They found that the growth rate is strongly influenced by the upstream history, thus confirming the significance of the initial conditions and further clarifying why the results based on the parallel-flow theory led to inconsistent results. They also stressed that a rigorous specification of physically relevant initial conditions would require the formulation of the receptivity problem, i.e., the inclusion of external perturbations, as we further discuss in §II.D. Wall cooling and pressure gradient effects were also investigated. Wadey [54] further tested the initial conditions used by Spall and Malik [53]. In either studies, the free-stream disturbances were not accounted for, i.e., the receptivity problem was not solved.

A major difference between incompressible and compressible Görtler instability is the temperature adjustment layer, first analyzed in Hall and Fu [50] using a high-Reynolds number asymptotic method. The terms adjustment-layer mode or trapped mode have been used interchangeably and we adopt the first terminology herein. In this layer, which only appears at the edge of a boundary layer in the hypersonic limit  $M_\infty \gg 1$ , the base-flow temperature changes rapidly to its free-stream value. For Görtler vortices with large wavenumbers, Hall and Fu [50] showed that the vortices are trapped in the adjustment layer and that the most dangerous vortices are those with wavelengths comparable with the adjustment-layer thickness. Dando and Seddougui [55] presented an extensive asymptotic analysis of compressible Görtler vortices in the inviscid limit of large Görtler number. As the Mach number increases, the growth rates of the wall-layer mode and the adjustment-layer mode were studied as functions of the spanwise wavenumber, demonstrating how the adjustment-layer mode becomes important when the Mach number exceeds a critical value. Dando and Seddougui [55] included a useful table summarizing the most relevant studies where nonparallel-flow effects were accounted for in a rigorous manner. Further studies on the linear development of compressible Görtler vortices include those of Fu et al. [56] and Fu and Hall [57], which focused on the influence of real-gas effects and spanwise cross flow, respectively.

As small-amplitude perturbations initially grow linearly until nonlinearity sets in, weakly nonlinear theory was used to analyze the first stages of the nonlinear evolution of Görtler vortices. By assuming a small growth rate in the neighborhood of the neutral position, weakly nonlinear theory was employed by Stuart [58] to investigate nonlinear incompressible instability waves (refer to Wu [59] for a review of high-Reynolds-number nonlinear stability theories for boundary-layer flows). Fu and Hall [60, 61] extended the incompressible weakly nonlinear theory of Hall [62] and Hall and Lakin [63] to study the growth of Görtler vortices in a hypersonic boundary layer at streamwise locations  $x - x_c \ll 1$ , where  $x_c$  is the neutral point of stability. At  $x - x_c = O(1)$ , the weakly nonlinear theory becomes invalid and the dynamics of the Görtler vortices is fully nonlinear. The weakly nonlinear theories of Hall [62] and Hall and Lakin [63] for Görtler vortices turn out to be rather different from the

classical weakly nonlinear theory for other typical shear-flow instabilities. Hall [62] and Hall and Lakin [63] found that the fundamental wave drives the mean flow directly, while, in the classical weakly nonlinear theory, it generates the mean-flow distortion through nonlinear effects.

Fu and Hall [60, 61] also developed a fully nonlinear theory to study the development of compressible Görtler vortices downstream of the neutral point. The nonlinear distortion of the mean velocity and temperature was computed and the vortices were found to occur in a region bounded by two transition layers, a result also obtained by Wadey [64]. The dynamics is described by a free boundary problem, which Fu and Hall [60, 61] solved numerically. Fu and Hall [65] extended the theory of Fu and Hall [60] to find that wall cooling increases the growth of the induced Rayleigh modes. Lipatov and Bogolepov [66], Bogolepov and Lipatov [67] and Bogolepov [68, 69] studied the linear and nonlinear evolution of long-wavelength vortices in hypersonic boundary layers in the limit of large Görtler number. Their nonlinear analysis showed that surface heating stabilizes Görtler vortices, a result that is consistent with the linear results of Kobayashi and Kohama [29] and Elliott and Bassom [70], and with the nonlinear results of Spall and Malik [53] and Fu et al. [56]. Bogolepov [68], Bogolepov [69] and Elliott and Bassom [70] all showed that wall cooling destabilizes Görtler vortices, but Elliott and Bassom [70] also remarked that extreme cooling could instead render them more stable. All these results, however, do not reconcile completely with the findings of Kahawita and Meroney [31] and El-Hady and Verma [34], discussed in §II.B, as the influence of wall-heat transfer appears to depend on the spanwise wavenumber range as well.

The linear stability results were utilized in Ren and Fu [25] to initiate the downstream computation of the steady nonlinear boundary-layer equations. Since the receptivity mechanism was not taken into account because the free-stream disturbances were neglected, the amplitude of the eigensolutions was assigned according to experimental observation. The alteration of the transition location due to different amplitudes in the stage of modal growth merits further research. Up to  $M_\infty = 3$ , the saturation stage was clearly attained and the crossover of the most amplified modes was observed. As the hypersonic regime was established, the thermal disturbances became dominant over the kinematic disturbances, similarly to the scenario of nonlinear supersonic streaks induced by free-stream disturbances [48]. The thermal disturbances prevented the amplitude of the Görtler vortices to saturate to an almost constant value. More recent work utilizing the nonlinear boundary-region equations by Es-Sahli et al. [71, 72, 73] focused on the control of compressible Görtler vortices, either by wall-heat transfer or by a Lagrange-multiplier optimal technique. The vortices were triggered by localized wall transpiration, while free-stream perturbations were absent.

We remark that, if free-stream perturbations, wall roughness or wall transpiration are not included in the formulation, the initial conditions from which the marching procedure is started must be assigned at a user-specified streamwise location because no external agent is active in exciting the boundary layer. One practice to obtain the initial condition is to use the optimal-growth theory [74, 75], where the initial condition is found by an iterative procedure. This approach was used by Lucas et al. [76] to study the compressible Görtler vortices. The idea of unique neutral curve, dismissed by Hall [12, 45], was reinstated because a defined initial condition was attained by the iterative procedure. However, since the optimal perturbations depend on the streamwise location of the initial condition and on the control function chosen by the user for the iteration, the uniqueness of the neutral curve is an artifact. Optimal perturbations have no connection with naturally present external physical disturbances, nor are they likely to be excited by viable actuators. It is therefore unclear how calculations using such perturbations could serve any practical purpose.

## 2. Parabolized stability equations

Herbert [77] gives a state-of-the-art account on the method of the parabolized stability equations (PSE), used extensively to study boundary-layer stability and the early phases of transition. We herein present a brief overview of the PSE methodology and discuss research studies where PSE have been used to investigate compressible Görtler instability. The compressible PSE framework has been first formulated by Chang et al. [78] and Bertolotti and Herbert [79].

In the two-dimensional case, the base flow is written as  $\mathbf{Q} = (U, \epsilon_s V)(\hat{x}, y)$ . The flow is decomposed as

$$\mathbf{q} = \mathbf{Q}(\hat{x}, y) + \hat{\mathbf{q}}(\hat{x}, y) \exp \left[ i(\beta z - \omega t) + i \int_{\hat{x}_0}^{\hat{x}} \alpha(\tilde{x}) d\tilde{x} \right] + \text{c.c.}, \quad (7)$$

where  $\hat{x} = \epsilon_s x$  is the slowly varying streamwise coordinate,  $\epsilon_s = O(Re^{-1}) \ll 1$  and  $Re$  is the Reynolds number based on the displacement thickness. The streamwise wavenumber  $\alpha(\hat{x})$  in expression (7) has to be chosen such that the perturbation shape function  $\hat{\mathbf{q}}(\hat{x}, y)$  varies slowly in  $x$  to enable the neglect of the second-order term  $\partial^2 \hat{\mathbf{q}} / \partial x^2$ . Substituting (7) into the

Navier-Stokes equations and neglecting the high-order terms yield the nonlinear parabolized stability equations [77],

$$(\mathcal{L} + \epsilon_s \mathcal{L}') \hat{q} + \epsilon_s \mathcal{M} \frac{\partial \hat{q}}{\partial \hat{x}} = \mathcal{N}, \quad (8)$$

where the operators  $\mathcal{L}$ ,  $\mathcal{L}'$  and  $\mathcal{M}$  act along  $y$  only and  $\mathcal{N}$  includes the nonlinear terms. By neglecting the nonlinear terms  $\mathcal{N}$  in (8), one finds the linearized parabolized stability equations, while the simplifications  $\epsilon_s = 0$  and  $\mathcal{N} = 0$  in (8) retrieve the system (6) for the parallel-flow LST. Setting  $\alpha = 0$  leads to the nonlinear boundary-region equations because the streamwise viscous diffusivity and the streamwise pressure gradient of the flow disturbance are absent and no streamwise ellipticity is retained [47, 48, 80, 81].

The PSE constitute an initial-boundary-value system that describes the evolution of the seeded disturbances and are solved numerically by marching downstream. A supplementary condition for the determination of  $\alpha(x)$  is

$$\int_0^\infty \rho_0 \left( \hat{u}^\dagger \frac{\partial \hat{u}}{\partial \hat{x}} + \hat{v}^\dagger \frac{\partial \hat{v}}{\partial \hat{x}} + \hat{w}^\dagger \frac{\partial \hat{w}}{\partial \hat{x}} \right) dy = 0, \quad (9)$$

where  $\rho_0$  is the base-flow density and the superscript  $\dagger$  denotes the complex conjugate. The integral norm (9) provides the iterative condition for the computation of the wavenumber  $\alpha$ . The iteration on (9) is unnecessary for Görtler vortices with order-one spanwise wavelength and Görtler number because of their long streamwise length scale. Ren and Fu [44] used a modified iterative procedures involving expression (9) normalized by the local kinetic energy. It should be noted that the PSE exhibit weak ellipticity along the streamwise direction. As first discussed by Chang et al. [78], this ellipticity causes problems for their numerical integration, such as the occurrence of numerical instability when the streamwise step size is too small. Li and Malik [82] further derived the step-size limit for stable PSE marching.

Conceptually intuitive and computationally efficient, the PSE method became a popular tool for studying the nonlinear evolution of Görtler vortices. Li et al. [83] solved the nonlinear PSE to study Görtler instability in a Mach-6 boundary layer. Eigensolutions to the linear parallel-flow stability problem were used as initial conditions for the PSE computation. They found that the mushroom structures, common in flows dominated by Görtler vortices from the incompressible regime to the mildly supersonic regime (refer to figure 1), only appeared when the vortices were fully nonlinearly saturated. Bell-shaped structures instead occurred during the initial evolution, a scenario that chimes with the wind-tunnel visualizations of Huang et al. [84].

Ren and Fu [44], Ren et al. [85] and Ren and Fu [43] also used the linearized eigensolutions to initiate their nonlinear PSE computations. Ren and Fu [44] confirmed the linearized results that the adjustment-layer mode dominates in the hypersonic regime, but it is superseded by the wall-layer mode when the Görtler number is sufficiently large. The study of Ren et al. [85] revealed that the dominance of the bell-shaped structures over the mushroom structures is due to the prevalence of the adjustment-layer mode. Liu et al. [86] further showed that the linearized compressible PSE calculations of compressible Görtler vortices agreed very well with results from DNS.

The PSE framework has also been useful for the study of the nonlinear interactions between Görtler vortices and other instability modes, such as the inviscid Mack mode. Song et al. [87] utilized the PSE approach to study the nonlinear evolution of finite-amplitude Görtler vortices and Mack modes of much smaller amplitude. They found that varicose and sinuous modes originated from the Mack modes and the growth rate was modified. Chen et al. [88] employed linear-stability eigensolutions to initiate the nonlinear PSE calculations of compressible Görtler vortices at  $M_\infty=6$  over a flared cone with a sharp leading edge. They computed the growth of both the second Mack mode and Görtler vortices. The second Mack mode dominated at high frequencies (around 350 kHz), while Görtler vortices controlled the low-frequency portion of the spectrum (around 50 kHz).

#### D. Initial-boundary-value approach with free-stream disturbances: receptivity theory

As discussed in the previous sections, the problem of Görtler instability is described mathematically by a system of partial differential equations that is parabolic along the streamwise direction. It therefore follows that both the initial conditions near the leading edge and the free-stream conditions are indispensable ingredients for the correct description of the Görtler-instability problem. Studies based on the local eigenvalue stability theory in §II.B and on the initial-value theories in §II.C neglected the impact of free-stream disturbances. As a consequence, the initial conditions for all those initial-value Görtler instability computations were assigned without being related to the external disturbance flow, for example by utilizing the discrete normal stability modes [25, 83, 89]. However, it should be noted that this practice is unsatisfactory for Görtler instability because nonparallelism plays an order-one role near the leading edge.

These observations point to the crucial issue: the receptivity process, i.e., how external disturbances enter the boundary

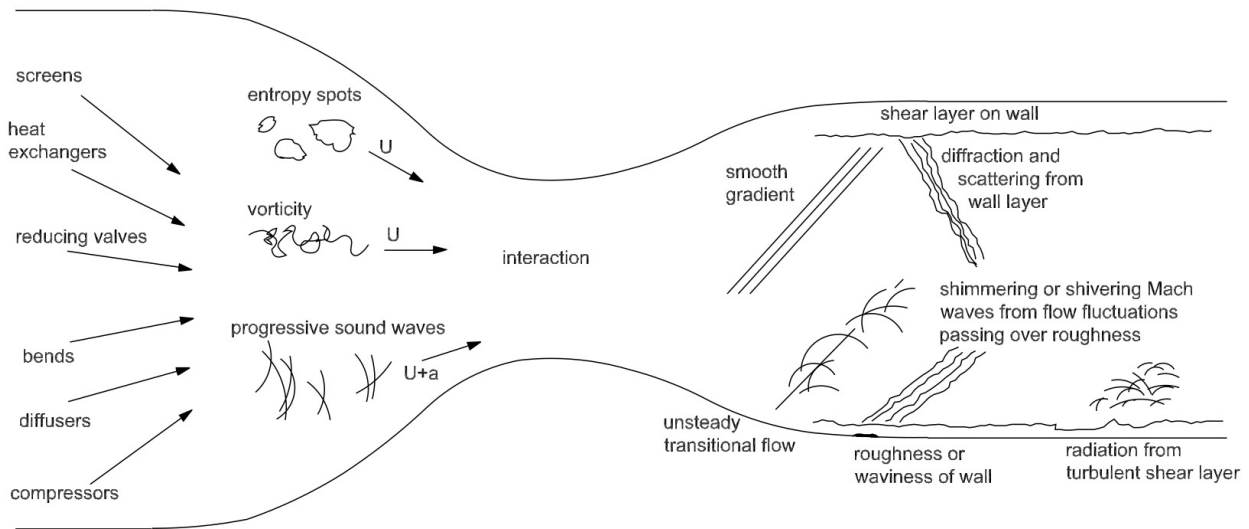

**Fig. 2 Free-stream disturbances in supersonic wind tunnels. Taken from figure 2 in Schneider [4] by courtesy of Prof. Steven P. Schneider.**

layer to trigger unstable modes, which, in the case of boundary layers over a concave wall, include Görtler vortices. The receptivity framework resolves two central issues. It explains how the external disturbances are entrained into the boundary layer and engender the growing boundary-layer disturbances. It also univocally determines both the shape and amplitude of the initial perturbation near the leading edge. An indissoluble connection exists between the external disturbances and the initial conditions because the former is responsible for the latter. Other approaches fail in these regards because the penetration of free-stream fluctuations into the boundary layer is not included and the initial conditions is specified rather arbitrarily without being linked to the external disturbances.

We now discuss the receptivity of compressible boundary layers over concave surfaces to free-stream disturbances. The reader is referred to Wu et al. [15] for results on the incompressible receptivity problem.

Disturbances in compressible free streams may consist of acoustic, vortical and entropy modes [90, 91], which can induce unstable perturbations in the boundary layer and lead the flow to transition to turbulence. Morkovin [92] discussed various sources of free-stream fluctuations in the nozzle of conventional ‘noisy’ supersonic and hypersonic wind tunnels, shown in figure 2 (redrawn from Schneider [4]). In addition to the free-stream disturbances from the upstream region, Morkovin [93] realized the importance of the sound radiated from the boundary layers on the nozzle walls. These acoustic disturbances become more dominant as the Mach number increases. Duan et al. [94] reviewed recent progress in the experimental and numerical characterization of free-stream disturbances in conventional hypersonic wind tunnels, focusing on the modelling of experimental free-stream spectra in DNS. The acoustic disturbances are a main concern at Mach numbers larger than 2.5 due to their dominance over vortical and entropy disturbances [95]. Free-stream vortical disturbances associated with atmospheric turbulence are important for the receptivity process under flight conditions at any Mach number.

The continuous modes of the Orr-Sommerfeld/Squire equations have been utilized to model the entrainment of free-stream vortical disturbances in boundary layers [96, 97]. This approach was however proved by Dong and Wu [98] and Wu and Dong [99] to be inappropriate for the representation of free-stream disturbances because of an unphysical “Fourier-mode entanglement”, abnormally large streamwise velocity of the disturbances in the free stream and, in the compressible regime, further entanglement of vortical and entropy disturbances, all arising because of neglecting the leading-order nonparallel-flow terms.

The theoretical study of boundary-layer receptivity to free-stream disturbances has progressed considerably in the last twenty years. Table 2 summarizes the main studies on the entrainment of unsteady free-stream vortical disturbances in laminar boundary layers over flat plates, leading to the formation of Klebanoff modes, and over concave surfaces, where Görtler vortices evolve downstream from Klebanoff modes. All these studies trace back to the theory of Leib et al. [47], an asymptotic framework based on the unsteady boundary-region equations in the limits of large Reynolds number and small frequency (or, equivalently, small streamwise wavenumber) [46]. Figure 3 depicts the different asymptotic regions of the theory by Leib

**Table 2** Studies on Klebanoff modes and Görtler vortices based on the initial-boundary-value receptivity theory for  $R_\Lambda \gg 1$ .

	Flat plate ( $G_\Lambda = 0$ )		Concave wall ( $G_\Lambda = O(1)$ )	
	Incompressible	Compressible	Incompressible	Compressible
Linear theory	Leib et al. [47]	Ricco and Wu [80]	Wu et al. [15]	Viario and Ricco [16, 100]
Nonlinear theory	Ricco et al. [101], Zhang et al. [102]	Marensi et al. [48]	Xu et al. [24], Marensi and Ricco [103]	Sescu et al. [104]

et al. [47], applicable to Klebanoff modes and Görtler vortices. In the linearized case, the turbulence Reynolds number is  $r_t = \epsilon R_\Lambda \ll 1$ , where  $\epsilon$  is the amplitude of the free-stream disturbance and  $R_\Lambda$  is the Reynolds number based on  $\Lambda^*$ . The free-stream disturbance flow is obtained either analytically or numerically, unequivocally fixing, via matched asymptotic expansions, the initial and free-stream boundary conditions for the boundary-layer flow. Ricco et al. [105] further discussed this theory in the context of other approaches and obtained good agreement between theoretical, experimental, and numerical data. When  $r_t = O(1)$ , nonlinearity plays a crucial role in the development of Klebanoff modes [101, 102]. Ricco and Wu [80] and Marensi et al. [48] extended the studies of Leib et al. [47] and Ricco et al. [101] to the respective compressible cases.

In the initial-boundary-value formulation, free-stream disturbances play a crucial role in the entire evolution of the boundary-layer flow, even in the fully nonlinear stage of well-developed Görtler vortices or Klebanoff modes. This theoretical framework treats the formation of Klebanoff modes and Görtler vortices as a unified phenomenon, which is convenient because, at moderate and high levels of free-stream disturbances, it is difficult to differentiate between the two types of disturbances. Wu et al. [15] extended the flat-plate study of Leib et al. [47] to the case of incompressible boundary layers over concave surfaces. For  $r_t \ll 1$ ,  $R_\Lambda \gg 1$  and  $G_\Lambda = O(1)$ , Wu et al. [15] focused on the linear excitation and evolution of steady and unsteady Görtler vortices. Their numerical results compared well with the experimental data. Similar to the flat-plate case, the generation of Görtler vortices is governed by the nonlinear boundary-region equations when  $r_t = O(1)$ . This problem was studied by Xu et al. [24] and Marensi and Ricco [103], while the effect of streamwise pressure gradient was investigated by Xu et al. [106] and Xu and Wu [107].

The evolution of compressible Görtler vortices over concave surfaces triggered by small-amplitude free-stream disturbances of the gust type was investigated for the first time by Viario and Ricco [16]. Their study can be viewed as an extension of the formulation of Wu et al. [15] for incompressible boundary layers or as a generalization of the study of Ricco and Wu [80] to include centrifugal effects. As a complementary study to Viario and Ricco [16], Viario and Ricco [100] computed the neutral map of the compressible flow dominated by Görtler vortices, following the incompressible study of Viario and Ricco [81]. The neutral map could be uniquely defined thanks to the receptivity framework, which allowed the precise specification of the oncoming free-stream perturbation flow. Highly-oblique Tollmien-Schlichting waves, generated by the leading-edge receptivity mechanism discovered by Ricco and Wu [80], were also found to operate when the wall was curved. Viario and Ricco [16, 100] solved the boundary-region equations and also adopted two eigenvalue frameworks, based on the parallel-flow and nonparallel-flow assumptions and on a high-Görtler-number asymptotic formalism that was revelatory of the different stages of the flow evolution. Viario and Ricco [16, 100] investigated the effects of frequency, ratio of free-stream wavelengths, Mach number and Görtler number, focusing particularly on the growth rates, the streamwise length scale, and the location of the velocity and temperature perturbations.

The crucial point is that both the initial conditions and the free-stream boundary conditions were determined by the oncoming disturbance flow, following Leib et al. [47]. The eigenvalue approach instead accounts neither for the initial conditions, because it is a local approximation, nor for the free-stream forcing, because it is based on a homogeneous system. Therefore, eigenvalue calculations only allow determining the growth rate and the streamwise length scale of Görtler vortices sufficiently downstream from the leading edge. Viario and Ricco [16] showed that the receptivity solutions eventually matched the eigenvalue solutions downstream and that it was only through the receptivity framework that the amplitude of the vortices could be uniquely computed and linked to the amplitude of the free-stream perturbation. Most importantly, the eigenvalue formulation led to incorrect results not only near the leading edge, but also at locations comparable with the streamwise wavelength of the free-stream flow. These streamwise stations were not close to the leading edge and only the receptivity analysis could inform about the locations where the agreement between the two solutions was of good accuracy. Viario and Ricco [16, 100] proved that the inclusion of the correct initial and free-stream forcing was essential to compute the flow from the leading edge, especially in supersonic conditions. It was also demonstrated that, when an amplitude was assigned arbitrarily

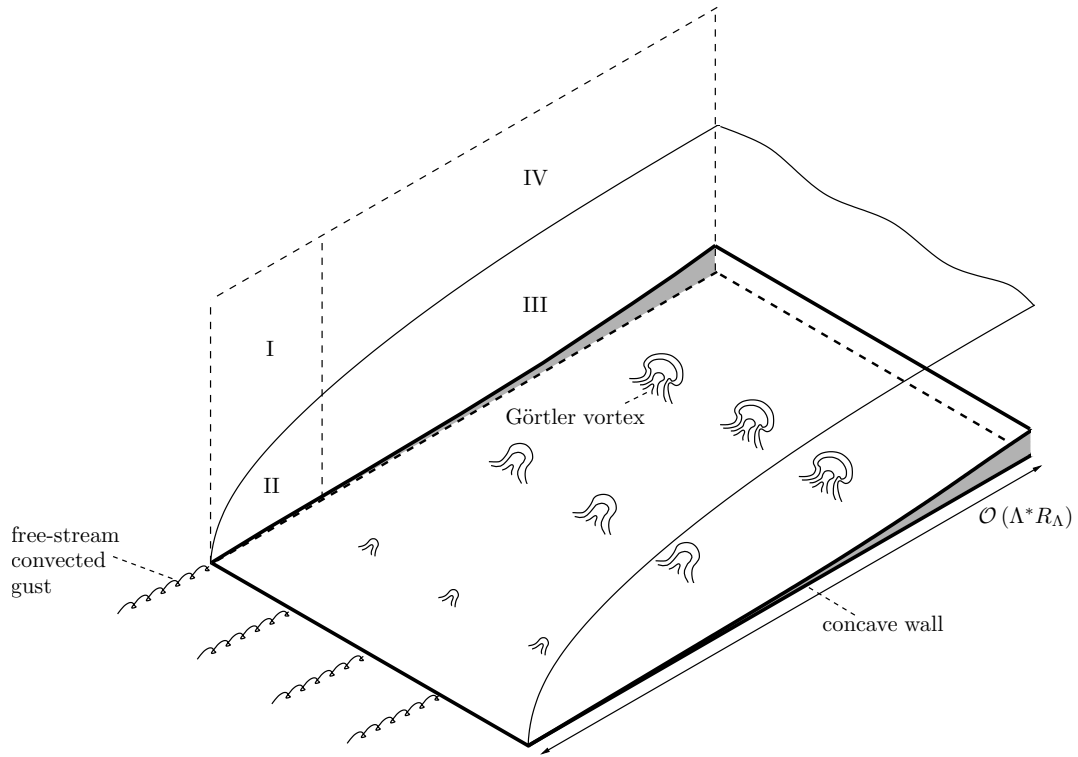

**Fig. 3 Schematic of a boundary layer exposed to free-stream vortical disturbances, based on Leib et al. [47], Ricco and Wu [80] and Wu et al. [15]. The Roman numerals indicate the asymptotic regions.**

to the eigenvalue solution to start the marching procedure and thus somehow bypass the modelling of the receptivity process from the leading edge, the shapes of the velocity, temperature, and pressure profiles were not accurate because the flow could only be computed rigorously by the correct initial conditions, fixed by the receptivity process.

Viaro and Ricco [16, 81, 100] considered weak free-stream disturbances, which correspond to a small turbulence Reynolds number ( $r_t \ll 1$ ). Sescu, Afsar, and Hattori [104] extended the work of Ricco and Wu [80] to study the nonlinear Görtler vortices excited by more intense free-stream disturbances, while Es-Sahli et al. [108] solved the steady boundary-region equations to study the effects of wall-heat transfer on Görtler vortices excited by wall transpiration.

### E. Secondary instability

Low-frequency nonlinear Görtler vortices saturate to a nearly constant amplitude and, by themselves, cannot lead to turbulence. Once the vortices acquire a significant amplitude, unstable secondary-instability modes of higher frequency may be supported by the saturated flow and be responsible for the breakdown of the flow. The secondary instability of incompressible Görtler vortices was studied by the inviscid method [89, 109], the global-eigenvalue method [110, 111] and the viscous biglobal method [24, 25]. The secondary instability of compressible Görtler vortices was analyzed by Fu and Hall [60], Li et al. [83], Ren and Fu [25], and Chen et al. [112]. The system describing the secondary instability of nonlinearly saturated Görtler vortices is given by equations (6)-(10) in Fu and Hall [60]. Fu and Hall [60] first studied the secondary instability of the nonlinear compressible Görtler vortices in the limits of large Mach number and large Görtler number, detecting inviscid secondary instability modes. Wall cooling and gas dissociation were found to increase the growth of the secondary instability modes. Ren and Fu [25] included viscous effects in their investigation of secondary instability by using the biglobal method. They identified three dominant secondary-instability modes in a hypersonic boundary layer: the varicose mode, the sinuous mode I and the sinuous mode II. These modes, whose terminology was coined by Swearingen and Blackwelder [113], are also important in incompressible boundary layers [24, 114]. Although the growth rate of a sinuous mode II may be lower than those of a varicose mode I or a sinuous mode I, a sinuous mode II dominates for large streamwise wavenumbers. Its eigenfunction is located in the bottom part of the Görtler vortices, which may support the flow breakdown in this region. The

Case	M0	M1	M2	M3	M4
B1	V	V	S-I	S-I	S-I
B2	S-II	S-II	S-I	S-I	S-I
B3	S-II	S-I	S-I	—	—

**Fig. 4** Secondary instability modes of compressible Görtler vortices. The letters V, S-I and S-II denote the varicose mode, the sinuous mode of type I, and the sinuous mode of type II, while MX denotes the Mach number X. Taken from table 3 in Ren and Fu [25] with permission from CUP.

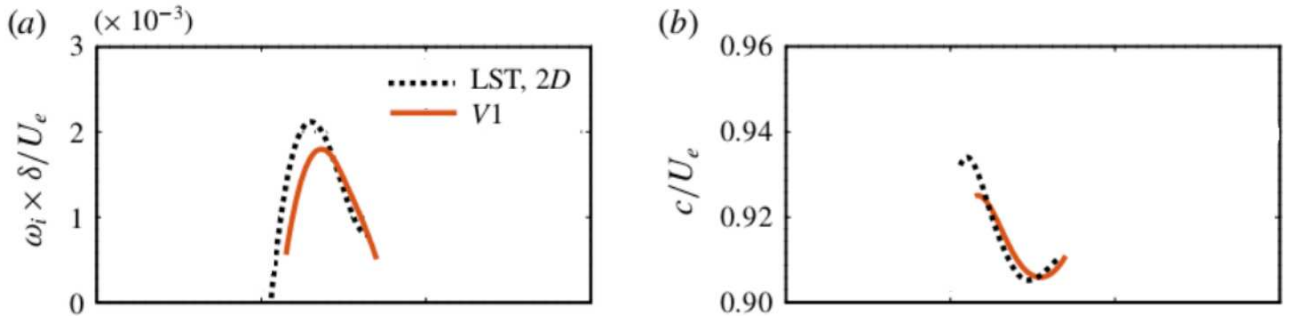

**Fig. 5** Growth rates (a) and phase speeds (b) of the second Mack mode (dashed line) and fundamental secondary instability mode (solid line) in a Mach 6.5 boundary layer over a planar concave wall. Adapted from figure 14 in Chen et al. [112] with permission from CUP.

dominant secondary-instability mode depends heavily on the seeded initial disturbances. Figure 4, taken from Ren and Fu [25], summarizes the main secondary-instability modes in compressible boundary layers dominated by Görtler vortices.

Recently, Li et al. [8] studied the secondary instability of hypersonic Görtler vortices excited by wall roughness. Their analysis revealed the presence of radiating secondary instability modes, first reported by Liu, Marensi, and Wu [7] for streaks developing in a flat-plate compressible boundary layer. The radiating secondary instability modes were also found in the secondary instability of streaks induced by wall heating [115]. These radiating modes are interesting because they may be directly related to the acoustic radiation, typical of hypersonic boundary layers on wind-tunnel nozzles.

Questions on the secondary Görtler instability of compressible flows remain open, such as the receptivity of nonlinearly saturated compressible vortices, leading to the excitation of secondary-instability modes. By comparing the two-dimensional linear-stability results with the biglobal results for a Mach 6.5 boundary layer over a planar concave wall, Chen et al. [112] indicated that the second Mack mode can become a secondary varicose mode, whereas the first Mack mode can develop into either a secondary instability sinuous mode or a secondary instability varicose mode, depending on its frequency and spanwise wavelength (refer also to Chen et al. [116]). Figure 5, adapted from figure 14 of Chen et al. [112], reveals the similarity of a secondary varicose mode with a Mack mode. The similarity of Mack modes and biglobal modes was also examined by Li, Choudhari, and Paredes [117] in a boundary layer on a Mach 6 cone with a concave aft body. Song et al. [87] further investigated the interplay between the secondary instability modes and the Mack modes by utilizing the biglobal method and the PSE method.

## F. Control of Görtler vortices

Motivated by the successful dampening of unstable cross flow modes achieved by Saric et al. [118], Li et al. [83] introduced subharmonic Görtler modes to attenuate the growth of the most dangerous primary Görtler mode, but the control strategy was not effective. Kuehl and Paredes [119] also observed that utilizing Görtler vortices to alter the base flow and stabilize the Mack modes may not be an effective method because, over a flared cone, the Görtler-perturbed flow was always more unstable than

the unperturbed base flow.

Ren et al. [120] extended the flow-control approach of Cossu and Brandt [121] to the compressible regime, i.e., finite-amplitude compressible streaks and Görtler vortices were used as a new base flow over which instability modes were computed. Differently from Li et al. [83] and Kuehl and Paredes [119], the altered instability modes exhibited lower growth rates because of the modified shear flow. The curvature was found to play a key role as it was more difficult to control the flow when the exponential growth of the Görtler vortices was too intense. The streaks and Görtler vortices were generated by optimal disturbance, i.e., free-stream disturbances were neglected.

Asymptotic and numerical methods were employed by Ricco and Fossà [122] to study vortical disturbances induced by free-stream disturbances in supersonic boundary layers over flat and concave porous surfaces. The growth rate of the boundary-layer disturbances was found to attenuate when the spanwise wavelength was much larger than the boundary-layer thickness. The vortical structures were instead unaffected by the porous substrate when the spanwise wavelength and the boundary-layer thickness were comparable. The growth of highly-oblique Tollmien-Schlichting waves was enhanced when the wall was porous.

### III. Experimental studies

Görtler vortices have been studied experimentally mainly in the incompressible regime [14, 21, 113, 123, 124] as it is more difficult to carry out boundary-layer experiments at high speeds. Only a few experiments have been conducted on compressible Görtler vortices over simple curved walls, while more effort has been devoted to experimental investigations of Görtler vortices over more complex surfaces that find direct applications in engineering problems (refer to table 3). In §III.A, we present the first studies where compressible Görtler vortices were visualized, in §III.B we discuss experimental results on compressible flows over simple concave walls, while the subsequent sections discuss studies on compressible Görtler vortices in more complex geometries.

#### A. First visualizations of supersonic Görtler vortices near reattachment lines

Ginoux [128] studied the laminar reattachment region downstream of a backward-facing step at  $M_\infty = 2.05$  and observed streamwise-elongated counter-rotating vortical structures. He surmised that these vortices could be of the Görtler type because of the curvature of the streamlines near the reattachment line. The orientation of the model and the step height were changed and the surface of the leading edge was polished, but vortices with the same wavelength were detected. Additional experiments by Ginoux [129] showed that the streamwise vortices in the reattachment region over two-dimensional backward-facing steps remained unchanged when the Mach number varied between 1.5 and 7. The images by Ginoux [128, 129], shown in figure 6 for  $M_\infty = 5.3$ , are regarded as the first visualizations of compressible Görtler vortices. The analysis of the sublimation and calorimetric data by Ginoux [130, 131] further suggested that the streamwise-elongated vortices in his experiments were created by small imperfections near the leading edge and were responsible for the well-defined spanwise variations of the skin friction and the wall-heat transfer.

The experiments of Ginoux [128, 129] inspired Inger [132, 133] to study the problem of Görtler instability for curved reattaching flows (refer to figure 7). He found that the curvature values, especially at reattachment, satisfied Görtler [11]'s criterion for centrifugal instability and the predicted amplitude and wavelength of the pressure variations agreed well with the measurements of Ginoux [128, 129]. The validity of these results has however not been confirmed because Görtler [11]'s criterion is based on parallel-flow calculations that have been questioned by subsequent theoretical studies, as discussed in §II.C. Another point of contention is that the results of Inger [132] are associated with specific locations of the recirculation region, while Görtler vortices require a longer portion of a concave surface to fully establish themselves.

#### B. Flows over simple concave walls

The first experiments of compressible flows over curved surfaces are, to the best of our knowledge, those of Chapman et al. [136], who measured the wall pressure of a boundary layer at  $M_\infty = 3$ , although no information could be inferred about the role of Görtler instability in the transition process. De Luca et al. [135, 137, 138] investigated Görtler instability in boundary layers over concave walls and wedges in a supersonic wind tunnel at the University of Poitiers. The Mach numbers ranged between 6.9 and 8.2. Spanwise periodic variation of the wall temperature indicated the presence of Görtler vortices and the spanwise-averaged Stanton number increased from the theoretically-predicted laminar value during transition, as shown in figure 8. The growth rates were predicted well by the instability theory. De Luca et al. [137] correctly remarked that, in order to carry out further quantitative comparisons with the theoretical results, more data about the wind-tunnel environment would

Görtler vortices over complex geometries						
	Unit	Reynolds number	Mach number	Görtler number $G_\theta$	Turbulence level	Reference
Quiet wind tunnel nozzles		$\leq 1.2 \cdot 10^7$	$\leq 6$	up to 10	<0.05%	Schneider [4]
Flared cones		$\leq 1.2 \cdot 10^7$	$\leq 6$		<0.05%	Chynoweth et al. [9]
Turbine blades		$10^6$	$\sim 0.9$	up to 5	5-20%	Cui et al. [125]
Compression ramps		$10^6$	up to 15	up to 1500 <sup>+</sup>	<0.05%	Simeonides and Haase [126], Balakumar et al. [127]
Hypersonic vehicles			up to 15	up to 1500 <sup>+</sup>	Atmospheric conditions	Balakumar et al. [127]

**Table 3** Experimental studies on compressible Görtler vortices in complex geometries. The superscript + denotes the Görtler number based on the displacement thickness.



**Fig. 6** Striation patterns near the laminar reattachment line of a flow at  $M_\infty=5.3$ , believed to be caused by Görtler vortices [129, 131].

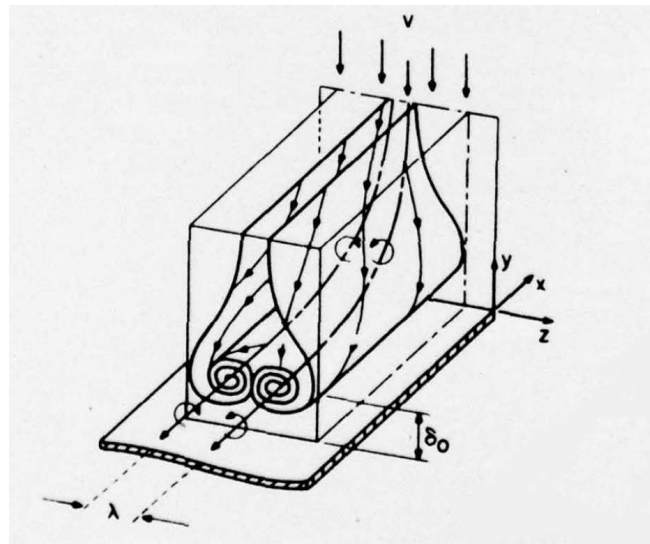

**Fig. 7** Spanwise-periodic disturbances in a reattaching flow. Taken from Namtu and Inger [134] and Inger [133].

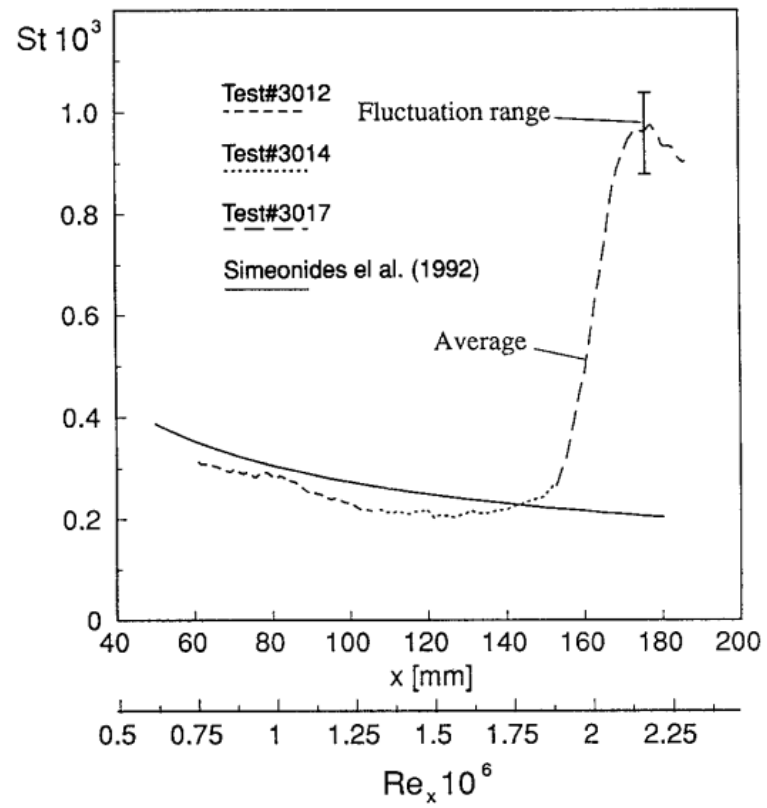
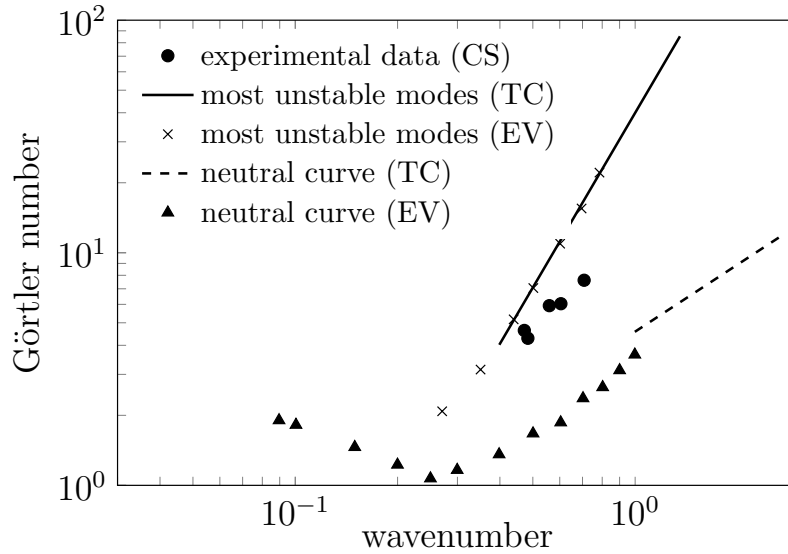

Fig. 8 Evolution of Stanton number along a curved surface due to Görtler vortices at  $M_\infty=7$  [135].



**Fig. 9** Experimental data for Mach 1.8-2.11 by Ciolkosz and Spina [140] (CS), compared to LST results by El-Hady and Verma [37] (EV) and Tumin and Chernov [141] (TC), reproduced from figure 12b in Ciolkosz and Spina [140].

be useful because flows dominated by Görtler vortices are strongly dependent on the external forcing conditions, as amply discussed in §II. Holden and Chadwick [139] measured the growth of the wall-heat transfer during transition to turbulence along a concave ramp at  $M_\infty = 10, 11, 12$ , but they did not report sufficient information on the flow perturbations to assess whether Görtler vortices played a role in the breakdown to turbulence.

Ciolkosz [142] and Ciolkosz and Spina [140] ran transonic and supersonic tests up to  $M_\infty = 2.87$  on flows developing on a curved ramp located in the Syracuse University supersonic wind tunnel. Görtler vortices were visualized by micro-carbon particulates and good agreement was achieved between their experimental results and LST results by El-Hady and Verma [37] and Tumin and Chernov [141], as shown in figure 9. The spanwise wavelength of the Görtler vortices was independent of the Mach number, the Reynolds number, and the radius of curvature. This result is consistent with the receptivity results based on the boundary-region equations, discussed in §II.D, as the spanwise wavelength is imposed by external flow perturbations, such as free-stream disturbances or wall roughness. The occurrence of the Görtler vortices detected by Ciolkosz [142] and Ciolkosz and Spina [140] was predicted by the theoretical results of Viaro and Ricco [16].

Flaherty and Austin [17] investigated the growth of the wall-heat transfer in laminar boundary layers over curved surfaces and ramps at  $M_\infty = 5.1$ . The heat transfer increased more over the curved surfaces than on the ramps and the data collapsed well when plotted versus the turning angle of the plate. In Flaherty and Austin [143], the Mach number was increased to  $M_\infty = 7.45$  and the heat transfer was enhanced by streamwise vortices generated by upstream equally-spaced vortex generators. Since the boundary-layer disturbances were not visualized, it was not evident whether the heat-transfer growth was due to the presence of Görtler vortices or to the adverse pressure gradient given by the wall geometry. Further details on their experimental procedures are found in Austin and Flaherty [144].

Wang et al. [145] performed flow visualizations of the complete evolution of Görtler vortices at  $M_\infty = 2.95$  from the laminar to the turbulent regime. Analogous to the theoretical flows studied by Viaro and Ricco [16, 100], the unsteadiness of the Görtler vortices was likely caused by the free-stream perturbation, since the plate was free from roughness. Decreasing the concave curvature delayed the boundary-layer transition. The dominant secondary instability modes were varicose, a different scenario from the incompressible case, where sinuous modes also play a role in the transition process. Huang et al. [84, 146] investigated the entire evolution of Görtler vortices in a Mach-6.5 boundary layer at Peking University. The Görtler vortices were triggered by equally-spaced roughness elements, but also occurred naturally over a smoothly curved surface. The typical mushroom shape of the Görtler vortices appeared during the last stage of flow evolution. Differently from Wang et al. [145], both sinuous and varicose secondary instabilities were detected, as shown in figure 10.

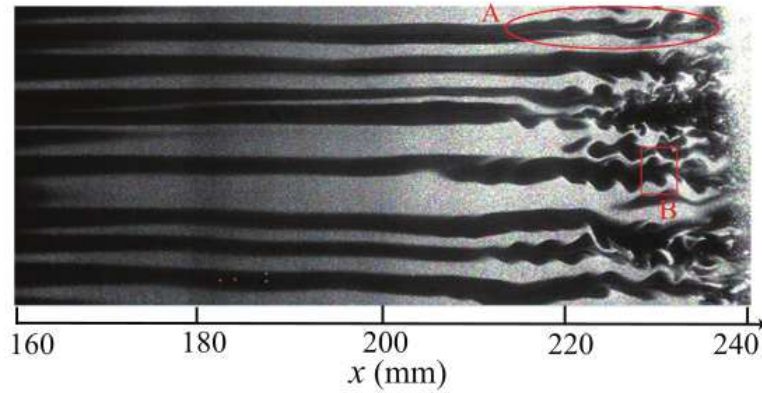

Fig. 10 Görtler vortices in a Mach-6.5 boundary layer obtained by the Rayleigh scattering technique in a quiet wind tunnel at Peking University. Image taken from figure 2 in Huang et al. [146] with permission from AIP.

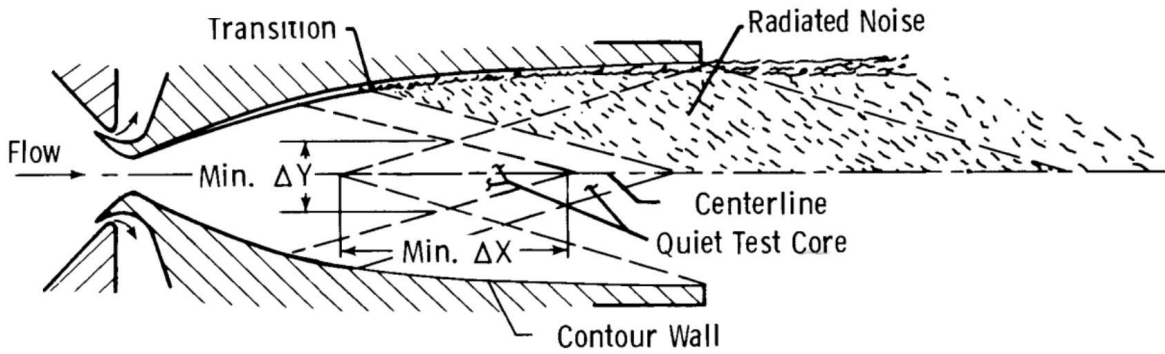

Fig. 11 Schematic of a supersonic nozzle in a Mach-3.5 wind tunnel, taken from figure 1 in Beckwith et al. [147].

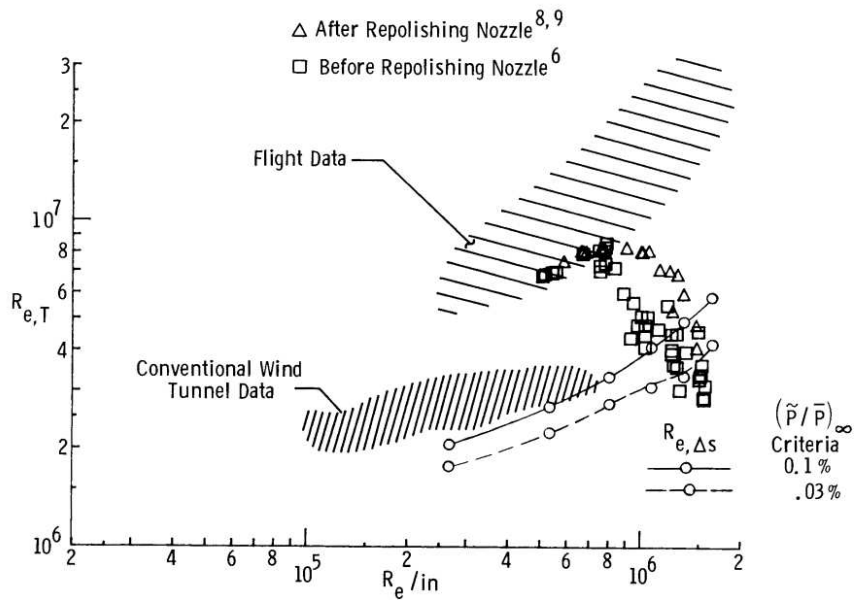

Fig. 12 Transition Reynolds number versus unit Reynolds number for a Mach-3.5 flow over straight cones. Taken from figure 5 in Beckwith et al. [147].

### C. Flows over nozzle walls

Figure 11 depicts a schematic of a Mach-3.5 wind-tunnel flow [147]. The transition location over the concave nozzle walls and the sound radiated from the turbulent boundary layers are shown. As the sound from wall turbulence may compromise the measurements in the test section, a requirement in the experiments of Beckwith et al. [147] was that the free stream had to be as quiet as possible to obtain reliable laboratory predictions of the flow in flight conditions. The quality and reliability of experimental tests in supersonic and hypersonic wind tunnels depend critically on the reduction of acoustic noise radiated from the turbulent boundary layers on the nozzle walls [4, 148–150]. The suction slots, visible in figure 11, have been useful to eliminate wall turbulence from the nozzle mouth. Pate and Schueler [151] showed that a reduction of free-stream noise and an enlargement of the wind-tunnel test section shifted the transition location downstream, thereby reducing the portion of the tunnel surface exposed to wall turbulence (refer to Pate [152, 153] for further discussions). As explained by Anders et al. [148] and Schneider [154], the experiments by Harvey et al. [155] at the NASA Langley Research Center revealed that a increase of 20% of the transition Reynolds number occurred when the nozzle wall was heated. This effect was primarily attributed to an increase in the boundary-layer thickness and a corresponding decrease in the sensitivity of the boundary layer to wall roughness.

Figure 12 shows the transition Reynolds number versus the unit Reynolds number for flows over straight cones [147]. The transition Reynolds numbers in flight conditions are much larger than those in supersonic wind tunnels because of the disturbed laboratory environment. This result highlights the importance of minimizing unwanted perturbations to obtain reliable flight-condition results in wind tunnels. Figure 12 also reports the benefit of carefully polishing the nozzle surfaces.

Compressible Görtler vortices have been recognized as one of the main causes of transition to turbulence over the concave surfaces of nozzles in supersonic wind tunnels [18]. Beckwith [156] and Beckwith and Holley [157] performed experiments in a quiet supersonic wind tunnel at the NASA Langley Research Center, and were the first to visualize Görtler vortices over the surface of a supersonic nozzle. Figure 13 shows the Görtler vortices in the contraction entrance and at the nozzle exit at two different Reynolds numbers. Beckwith and Holley [157] used the semi-empirical  $e^N$  method to predict the transition location caused by Görtler vortices, where  $N = -\int_{x_c}^{x_T} \alpha_i dx$ ,  $-\alpha_i$  is the growth rate and  $x_T$  is the location where transition occurs. No definitive conclusions were obtained about the exact  $N$  value. Beckwith and Holley [157] also reported that elongated structures appeared downstream of the transition point, which could mean that either the upstream Görtler vortices persisted through the wall-bounded turbulent flow region or that the observed streaky structures covered a long stretch of the transitional region. The precise role of the Görtler vortices in the transition process over the supersonic nozzle walls was not explained, although it was evident that the growth of Tollmien-Schlichting waves was not significant because of the favorable pressure gradient and the surface concavity. Beckwith et al. [158] arrived at the same conclusion when observing compressible Görtler vortices along the curved surfaces of the NASA Mach-3.5 rapid-expansion nozzle.

Chen et al. [159] utilized linear instability theory to compute the  $N$  factor for Görtler vortices on the walls of four supersonic nozzles. They obtained the  $N$  factors at transition and demonstrated, for the first time, the advantage of small nozzle-wall inflection angles. The  $N$  factor obtained by Chen et al. [159] ranged from 3.5 to 10.9, although they advocated the use of 9.2 for the design of long nozzles. We argue here that there cannot exist an exact  $N$  value for transition caused by any instability, especially Görtler instability. The failure of the precise determination of  $N$  is attributed to the dynamics of Görtler vortices, which must be treated as an initial-boundary-value problem rather than a local problem, i.e., receptivity plays a crucial role, as discussed in §II. Further discussion on the use of the  $N$ -method for the study of Görtler instability is found in Viaro and Ricco [81].

Chen et al. [159] also proposed the use of longer nozzles for a downstream shift of transition to turbulence. The idea was to achieve the transition shift via a delay of Görtler instability caused by the larger radius of curvature. This concept was implemented successfully by Chen et al. [160]. A straight-wall radial flow section was inserted upstream of the inflection point of the nozzle walls to suppress Görtler instability in a Mach-3.5 flow (more discussion is found in Chen and Wilkinson [161]). Chen et al. [162] utilized this design concept in a Mach-6 wind tunnel (refer also to Blanchard et al. [163]).

Interest in the design of Chen et al. [160] was pursued by Doggett and Chokani [164] and Doggett et al. [165], who used a series of fine meshes upstream of the nozzle mouth to attenuate vorticity and entropy fluctuations, bleed slots at the nozzle mouth to eliminate the turbulent boundary layers, highly polished wall surfaces and an initially straight contour of the nozzle wall to delay the development of Görtler vortices. Schneider [154] also indicated that a long nozzle can reduce the  $N$  factor of Görtler instability. To improve the  $e^N$  method, he also advocated further research on the physics of transition, based on receptivity and secondary instability. A long nozzle was also used in the Texas A&M University Mach-6 Quiet Tunnel with the purpose of suppressing the formation of Görtler vortices [166]. Related discussions are found in Schneider [4, 19], where compressible Görtler instability is discussed in the wider context of hypersonic transition in quiet wind tunnels. Schneider [19] further mentioned that, at that time, only three Mach-6 wind tunnels could be defined as ‘quiet’ because long portions of the

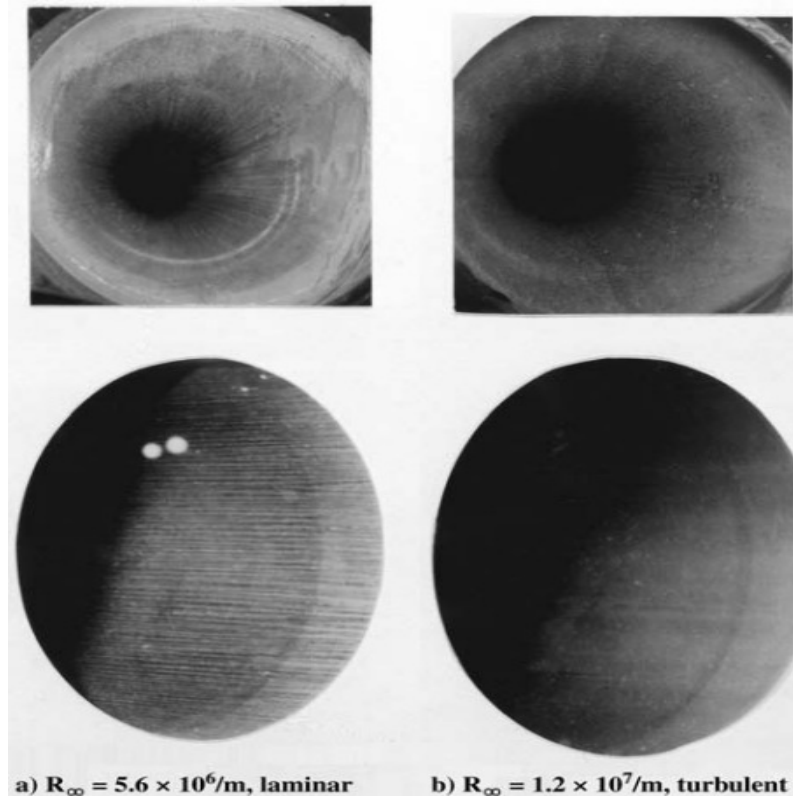

**Fig. 13** Oil-flow photographs of compressible Görtler vortices over the walls of an axisymmetric Mach-5 wind tunnel. Taken from figure 3 in Schneider [4] (refer also to figure 7 of Beckwith and Holley [157]).

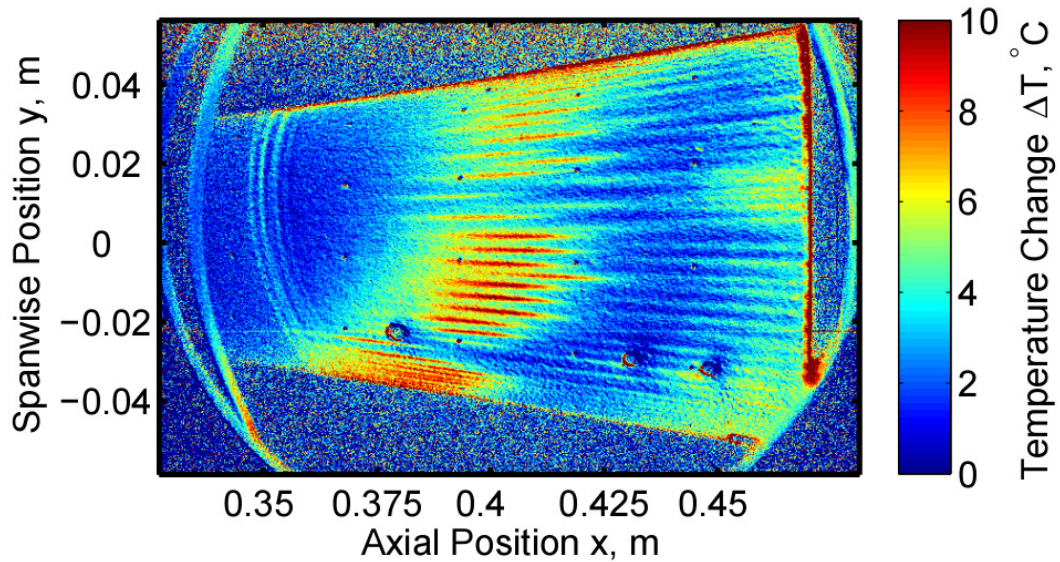

**Fig. 14** Wall heating on a Mach 6 flared cone at  $P_0^* = 140.3$  psia and  $T_0^* = 151.4^\circ\text{C}$ , measured in the BAM6QT at Purdue University. Taken from figure 21(a) in Ward et al. [172] by courtesy of Prof. Steven P. Schneider.

nozzle walls were wetted by laminar boundary layers, i.e., the Boeing/AFOSR Mach-6 Quiet Tunnel at Purdue University [167], the Mach-6 quiet tunnel at Peking University [168] and the Texas A&M University Mach-6 Quiet Tunnel [169, 170].

#### D. Flows over flared cones

A few experimental studies have focused on compressible Görtler instability in flows over flared cones. Table 4 lists these studies. The research interest in boundary layers over flared cones has been motivated by the richness and complexity of transition to turbulence in these flows, which is influenced by several factors, such as curvature, bluntness, pressure gradient, wall temperature, and angle of attack. We limit our discussion to compressible flows over flared cones aligned with the oncoming mean flow because stability and transition over cones at a nonzero angle of attack may be influenced by stationary and travelling cross-flow instability and, depending on the geometric configuration, on the attachment line instability as well.

Doggett and Chokani [164] and Lachowicz et al. [174] conducted hypersonic stability experiments under quiet conditions in the NASA Langley Mach 6 Nozzle Test Chamber (M6NTC). They reported that transition over a flared cone aligned with the free-stream flow was due to the second Mack mode. Doggett and Chokani [164] recognized the importance of the adverse pressure gradient over a flared cone, although no evidence of Görtler vortices was reported, arguably because of the large radius of curvature and the very low free-stream disturbance level. Experiments on a transitional boundary layer on a flared cone subject to wall cooling were carried out by Blanchard and Selby [175]. Wall cooling was found to be destabilizing, although the existence of Görtler vortices was not verified. Wilkinson [150] reviewed the early experiments on flows over flared cones in the Langley M6NTC. He argued that the double-peaked velocity and temperature profiles could be due to Görtler vortices only or to the combined effect of second Mack modes and Görtler vortices. Further experiments by Horvath et al. [176] revealed how free-stream disturbances lowered the transition Reynolds number over flared cones, although the effect of Görtler instability was not discussed. A summary of these experimental studies can be found in Schneider [177]. The Langley M6NTC was decommissioned in the late 1990s and was reestablished at Texas A&M University. Hofferth et al. [178], Hofferth and Saric [171] and Hofferth et al. [170] reproduced the stability experiments of Lachowicz et al. [174] and Doggett et al. [165] in the relocated wind tunnel.

Johnson et al. [179] optimized three-dimensional parametrically defined geometrical shapes to obtain minimum or maximum boundary-layer stability. Among their results was the design of an axisymmetric flared-cone surface that achieved a maximum  $N$  factor of approximately twice that of a baseline  $7^\circ$  half-angle cone with small bluntness. This successful design motivated other flared-cone experiments in quiet tunnels. Models of the optimal design were built and tested in the Boeing/AFOSR Mach-6 Quiet Tunnel (BAM6QT) at Purdue University. In the BAM6QT, Berridge et al. [180, 181] and Ward et al. [172] used temperature-sensitive paint to detect the surface heat flux. As shown in figure 14, streamwise-elongated patterns, named ‘hot

Flared cone experiments				
Quiet wind tunnels	Nominal Mach number	Maximum unit Reynolds number ( $m^{-1}$ )	Disturbances level $p'/p_{mean}$	Reference
NASA	5.9	$1.0 \cdot 10^7$	<0.1%	Wilkinson [150]
Texas A&M University	5.9	$1.1 \cdot 10^7$	<0.08%	Hofferth and Saric [171]
Purdue University	6.0	$1.1 \cdot 10^7$	<0.05%	Ward et al. [172]
Peking University	6.0	$1.0 \cdot 10^7$	<0.2%	Zhang et al. [168]
NUDT	6.0	$1.2 \cdot 10^7$	<0.1%	Liu et al. [173]

**Table 4** Experimental studies on compressible flows over flared cones. NUDT indicates National University of Defense Technology.

streaks', were observed under quiet conditions. Berridge et al. [180] could not evince the origin of these perturbations. They suggested that they could be due to Görtler vortices, to the interaction of Görtler vortices and second-Mack-mode waves, or to secondary-instability modes of the second-Mack-mode waves. It was interesting to note that these streaks grew in strength, unexpectedly weakened and almost disappeared downstream, and then regained energy before breaking down and leading the flow to transition. The boundary-layer thickness was estimated to remain constant during the flow evolution. This peculiar evolution only occurred in the quiet environment, not in the noisy environment. These streaks are further discussed in §IV.B. Ward et al. [172] attributed the formation of these elongated structures to the interaction of Görtler vortices with the second Mack mode. Berridge et al. [181] and Ward et al. [172] tried to control these perturbations by roughness dots located upstream of the painted surface. Although good agreement was found between the computed and the measured wall-pressure spectrum, the dots were not able to control the growth of the streaky structures.

On a flared cone with a sharp nose tip of 0.16 mm and an initial opening half-angle of 1.5 deg, Chou et al. [182] detected the striations of wall heating at about 38 cm from the nose tip. The cause behind these perturbations was again thought to be the nonlinear interaction between the second Mack mode and secondary-instability modes, or between the second Mack mode and Görtler vortices (further details are found in Chou [183]). Chynoweth et al. [9] reviewed the experimental studies carried out in the BAM6QT on boundary-layer transition over Mach-6 flared cones and discussed the simulations related to these experiments. They recognized the hot streaks as the cause of the large wall-heating overshooting over the turbulent values. They claimed that these wall striations were generated by steady streamwise vortices, which, in turn, arose from nonlinearly saturated second Mack modes.

Hofferth et al. [170] reported a peak in the energy spectrum of a boundary-layer flow over a flared cone in the Texas A&M University Mach-6 Quiet Tunnel, thereby detecting the presence of the second Mack mode of instability. No evidence of Görtler vortices was observed, arguably because of the mild curvature and limited streamwise extent of the model. Using the same tunnel, Craig et al. [184] measured high-intensity low-frequency disturbances in the boundary layer over a flared cone and noticed that this range of frequency could pertain to either first-mode instability or Görtler vortices.

A series of papers reported recent research conducted in the low-noise Mach-6 wind tunnel at Peking University [168, 185–189], focused on hypersonic flows over flared cones. The interested reader is also referred to the review by Lee and Chen [190]. The role of the second Mack mode on the breakdown to turbulence, its interaction with low-frequency waves, and the aerodynamic heating on flared cones were investigated. Hot streaks, such as those visualized in the BAM6QT, were also detected, as shown in figure 15 [185]. Liu et al. [173] used the hypersonic quiet wind tunnel at the National University of Defense Technology [191] to investigate the nonlinear evolution of the second Mack mode on a flared cone and reported the existence of high-frequency harmonics.

In these studies, low-frequency disturbances measured in boundary layers over flared cones were often thought to be the direct footprint of free-stream perturbations. Lachowicz et al. [192] suggested that these low-frequency disturbances were not associated with Görtler instability because they had also been detected over straight cones. One may therefore surmise that these perturbations were low-frequency thermal Klebanoff modes, such as those investigated by Marensi et al. [48], because the influence of curvature was mild. As mentioned in §II.D, this problem can be analyzed using the initial-boundary-value receptivity theory in both cases, despite their different instability mechanism. The same mathematical equations, excluding the term related to curvature, and the same initial and boundary conditions can be applied to both flows.

The influence of free-stream disturbances on the hot streaks detected over flared cones, specifically on their disappearance and subsequent reappearance [180], and on the nonlinear interaction between Görtler vortices and second Mack modes, remains an important open avenue of research, as discussed further in §IV.B. The impact of the azimuthal curvature on the instabilities over flared cones has not been explored, yet.

## **E. Flows over compression ramps and impacted by impinging shocks**

Supersonic and hypersonic compression corner/ramp flows are ubiquitous over the surfaces of aerospace vehicles, such as flaps, elevons and rudders. The flow reattachment gives rise to excessive wall-heat transfer and a full understanding of this aerothermal flow mechanism is therefore essential for the optimal design of heat protection systems. In these regions, the streamlines are curved because of the recirculation bubble and could thus be causing the formation of Görtler vortices.

Flows over compression ramps were studied by Chapman et al. [136] with the objective of understanding the nature of compression shocks and transition to turbulence. They recognized the importance of curved streamlines, but no details were provided about the role of Görtler instability. The presence of striation patterns similar to those of Ginoux [128, 129] were also observed in reattaching high-speed flows over compression ramps and axisymmetric models [130, 131, 193]. These studies supported the idea that these striation patterns were caused by the same centrifugal instability responsible for Görtler vortices.

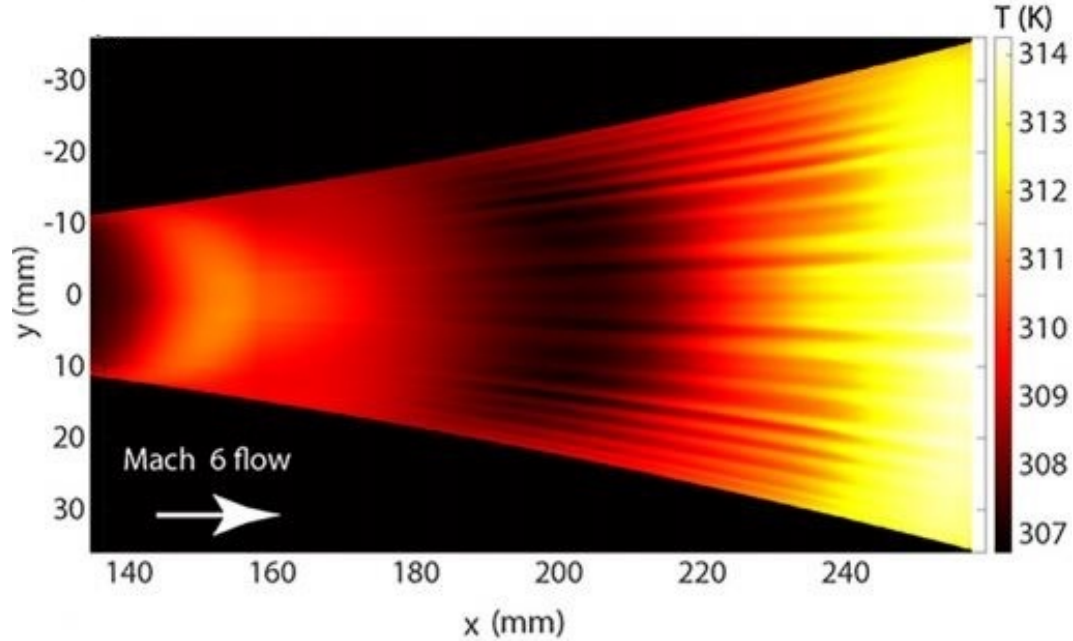

**Fig. 15** Surface temperature of a Mach 6 flared cone measured at Peking University. Taken from figure 1(a) in Zhu et al. [185] with permission from AIP.

Miller et al. [193] also surmised that these vortical structures were responsible for the increase of the wall-heat flux and wall pressure fluctuations. Motivated by these results, Namtu and Inger [134] and Inger [132] surmised that Görtler vortices may appear near points of ramp-induced separation, as sketched in figure 16.

De Luca et al. [194] observed spanwise-modulated wall striations of the Stanton number for flows over ramps at  $M_\infty=7.14$ . They remarked that further research was needed to evince whether these modulations were due to Görtler vortices and to assess the impact of the leading-edge shape and nonuniformities. Simeonides et al. [195], Simeonides and Haase [126], de la Chevalerie et al. [196] and Ishiguro et al. [197] also investigated the intense aerodynamic heating on hypersonic compression corners. Steady irregular heat-transfer striations were observed at the rear of the reattachment lines and were claimed to be related to Görtler vortices. Simeonides and Haase [126] and de la Chevalerie et al. [196] conjectured that the irregular spanwise modulation was caused by the variations of the leading-edge shape, in line with the idea that Görtler vortices are strongly dependent on upstream perturbations and irregularities. An overview on these results was presented by Marini [198].

Other visualizations of elongated striations of the wall-heat transfer were reported by Benay et al. [199] on an axisymmetric cylinder-flare model at  $M_\infty=5$ , by Zhuang et al. [200], who used nano-tracer planar laser scattering in a Mach-3 compression ramp flow, and, in hypersonic flows over compression ramps, by Schrijer [201] and Roghelia et al. [202] at  $M_\infty=7.5$  and  $M_\infty=7.7$ , and Zapryagaev and Kavun [203] and Trubitsyna et al. [204] at  $M_\infty=6$ . Recently, Li et al. [205] experimentally investigated vortices in the presence of dual-incident shock-wave/turbulent-boundary-layer interactions in a Mach 2.48 flow. The curvature of the streamlines in the reattachment region was recognized as the cause for the formation of Görtler vortices.

Chuvakhov et al. [206, 207] and Chuvakhov and Radchenko [208] conducted controlled experiments on a  $15^\circ$  compression corner flow at  $M_\infty=8$  with periodic roughness and measured the wall-heat transfer. Figure 17 shows their schlieren visualization of the wall-heat transfer over the compression ramp surface. The wall-heat flux is evidently enhanced between two adjoining striations at the wall, which could be due to the passage of Görtler vortices.

Stationary and time-dependent shocks impinging on boundary layers developing over fixed and cantilevered flat plates were studied in a Mach 5.8 Ludwieg tube located at the University of Southern Queensland [209–211]. The flows underwent transition where the shocks impinged on the surfaces. The wall-heat transfer showed distinct spanwise-periodic striation patterns in the separation and reattachment regions, likely produced by elongated vortical structures. They pointed out that a possible cause behind these structures was Görtler instability because of the large curvature of the streamlines in the vicinity of

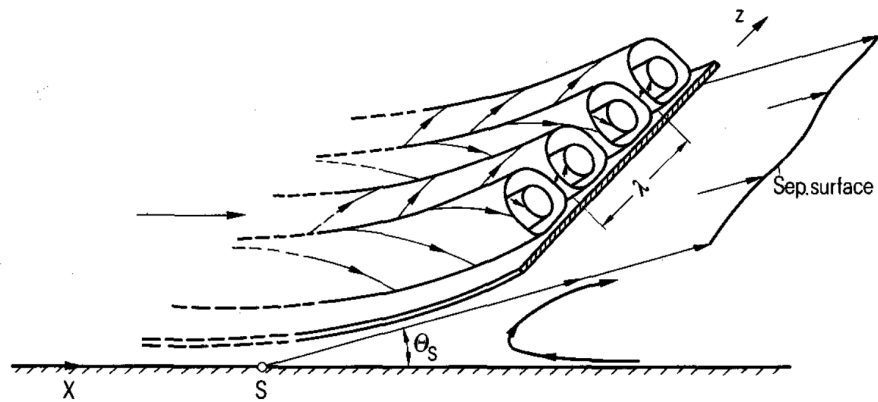

Fig. 16 Görtler vortices allegedly occurring in the proximity of a separation point. Taken from [132] with permission from Springer Nature.

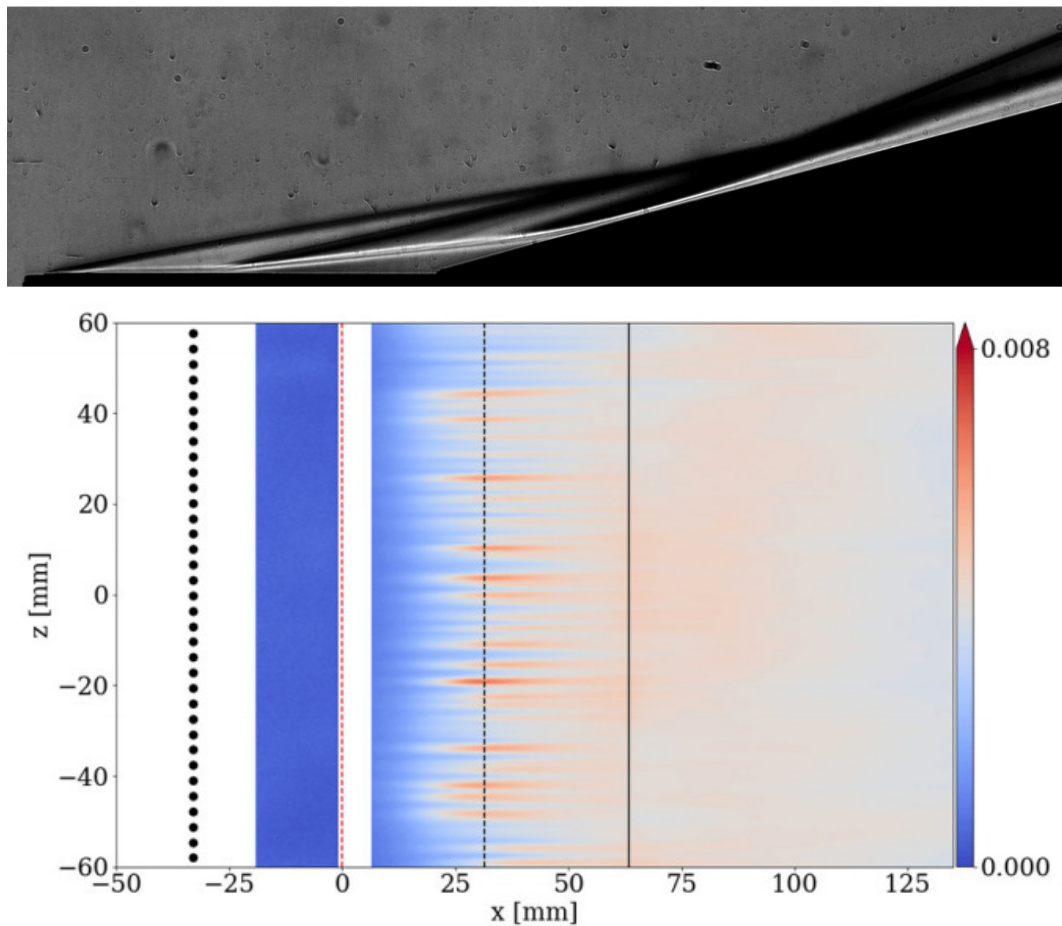

Fig. 17 Visualizations of flow over a compression ramp: schlieren image (top), Stanton number (bottom). Taken from figures 5a and 6b in Chuvakhov et al. [206] by courtesy of Dr Pavel V. Chuvakhov.

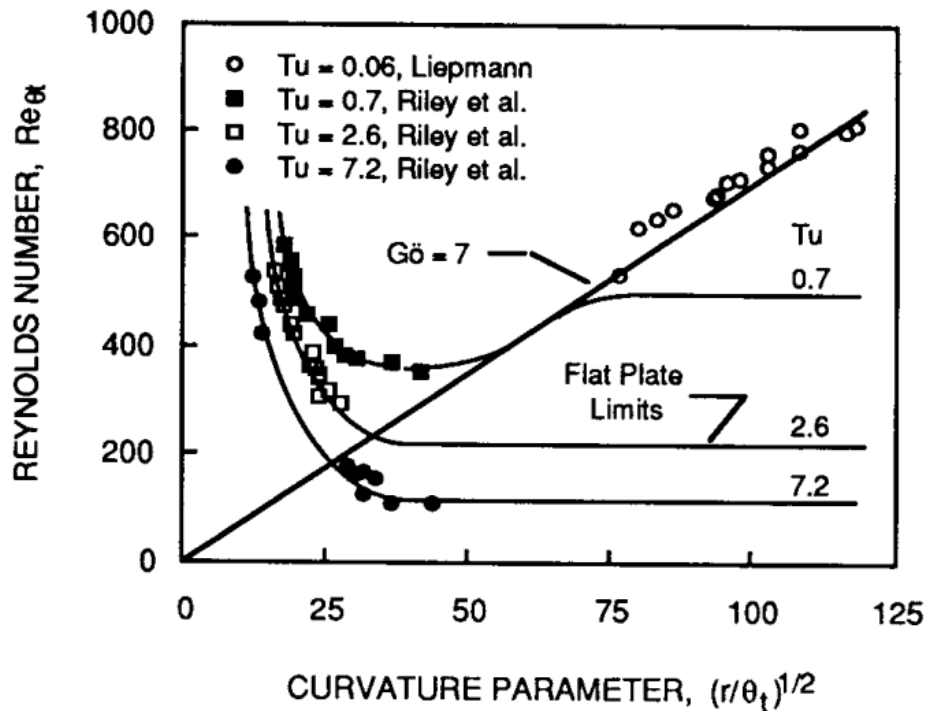

Fig. 18 The Reynolds number at the onset of transition on a concave surface as a function of the curvature parameter. Taken from figure A3 in Mayle [10] with permission from The American Society of Mechanical Engineers.

the impingement regions.

#### F. Flows over turbine and compressor surfaces

The turbulence levels at the inlet of turbine and compressor passages are often high, in the range of  $Tu = 5\% - 20\%$  [10]. Transition over turbine and compressor blades has therefore been recognized as an extremely difficult problem, given the sensitivity of boundary-layer instability to external forcing agents. It is central to predict how and where transition occurs in these flows because the energy losses, and therefore the performance of the whole fluid system, depend drastically on the flow regime of boundary layers. Mayle [10] reviewed the role of transition in gas-turbine engines and discussed the influence of curvature and turbulence level, albeit focusing primarily on incompressible flows. Figure 18 shows that the concave curvature can either reduce or increase the transition Reynolds number, depending on the external turbulence level. It is evident that the receptivity of boundary layers to external disturbances is of ultimate importance in the study of Görtler vortices over turbine and compressor blades. The underlying mechanisms of transition over turbine blades, and specifically the role of compressible Görtler vortices over the concave portion of the pressure surface, are still not well understood.

Several experimental papers have addressed the problem of Görtler instability over turbine and compressor surfaces, but, to the best of our knowledge, they have focused on the incompressible and the low subsonic regimes. The visual study of Han and Cox [212] highlights the possible interaction of Görtler vortices with vortices detaching from the trailing edge and with Tollmien-Schlichting waves over the concave pressure surface. Brown and Martin [213] discussed the importance of predicting Görtler vortices over the pressure surfaces of turbine blades in the presence of free-stream turbulence, focusing on the increase of wall-heat transfer in disturbed conditions (refer also to Riley et al. [214]). The wall-heat transfer measurements of Turner [215] and a number of heat-transfer correlations were also examined.

The heat-transfer problem on the pressure side has also been investigated by Baughn et al. [216]. They attributed the wall-heat transfer striations to Görtler vortices, occurring when the free-stream turbulence intensity was 1%. For turbulence intensities as high as 10%, the modulations were not detected, arguably because wall turbulence dominated the pressure



**Fig. 19 Hypersonic airbreathing vehicles. Left: X-43A (image from <https://www.nasa.gov/>). Right: X-51A (image from <https://media.defense.gov/>).**

side. Similar findings were reported by Butler et al. [217]: in a low-turbulence intensity environment ( $Tu=0.3-0.8\%$ ), the pressure side was populated by hot streaks that were arguably caused by Görtler vortices, while no streaks were detected in the high-turbulence case ( $Tu=10\%$ ). The measurements of Wang et al. [218] in low-turbulence conditions showed the presence of Görtler vortices on the pressure side. The vortices were thought to be generated by roughness at the leading edge of the blade. Their well-defined spanwise wavelength remained almost constant, independent of the boundary-layer thickness. This latter finding is in accord with the receptivity theory discussed in §II.D, for which the wavelength is solely determined by the external perturbations. Gostelow et al. [219, 220] carried out experiments on turbine blades in high-subsonic and transonic conditions at the Institute for Aerospace Research of the National Research Council of Canada. They visualized vortical structures with an exceptionally well-defined spanwise spacing, but unfortunately only on the suction side. These streaks were arguably a convex-surface analog of the thermal Klebanoff modes studied by Ricco and Wu [80] and Marensi et al. [48].

### G. Flows over hypersonic airbreathing vehicles

Görtler vortices are also ubiquitous in boundary layers over supersonic and hypersonic vehicles. Models used in the NASA Hyper-X programs, such as the X-43A vehicle shown in figure 19 (left) [221], have two compression corners, of  $5.5^\circ$  and  $3^\circ$ , following an initial wedge with an angle of  $2.5^\circ$ , along which the streamlines are curved and could be responsible for Görtler instability [222]. Figure 19 (right) depicts the X-51 Waverider, used by the U.S. Air Force Research Laboratory and the Boeing Company, which shows geometrical characteristics similar to the X-43A vehicle [221]. Figure 20, taken from Lee and Chen [190], depicts the temperature distribution over the concave surface of a scramjet model in a hypersonic wind tunnel. The streaky thermal structures were likely to be caused by roughness near the leading edge and by Görtler vortices developing over the surface. Further discussion on transition to turbulence on scramjet forebodies is found in Schneider [177].

Berry et al. [222] studied the Hyper-X forebody in the NASA Mach 6 and 10 tunnels and in the HYPULSE reflected shock tunnel at the General Applied Science Laboratory. They visualized streaky structures at  $M_\infty = 6$  by oil on the ramped surfaces of the model. They noted that these vortices persisted in the turbulent region as well.

Liu et al. [221] reviewed research on combustion stabilization for hypersonic airbreathing propulsion. They pointed out that, in scramjet engines, transverse jet injection could induce a counter-rotating vortex pair, as shown in figure 21. Although it is not clear at present, these jet-injection vortices, caused by recirculation bubbles or compression corners, could be subject to Görtler instability if transported downstream by concave base-flow streamlines.

## IV. Numerical studies

Görtler instability and the related transition to turbulence have also been investigated by high-resolution DNS. Due to the high computational costs of this numerical approach, the existing DNS studies have largely focused on the nonlinear evolution and secondary instability of numerically seeded vortices and their interactions with first-mode and second-mode instabilities. The main objective was to compare the DNS results with the results from stability theories, such as the LST and the PSE method. As discussed in the following subsections, the initial receptivity of concave-wall boundary layers to free-stream disturbances has received very limited attention via DNS and thus merits further research. The persistence of Görtler vortices

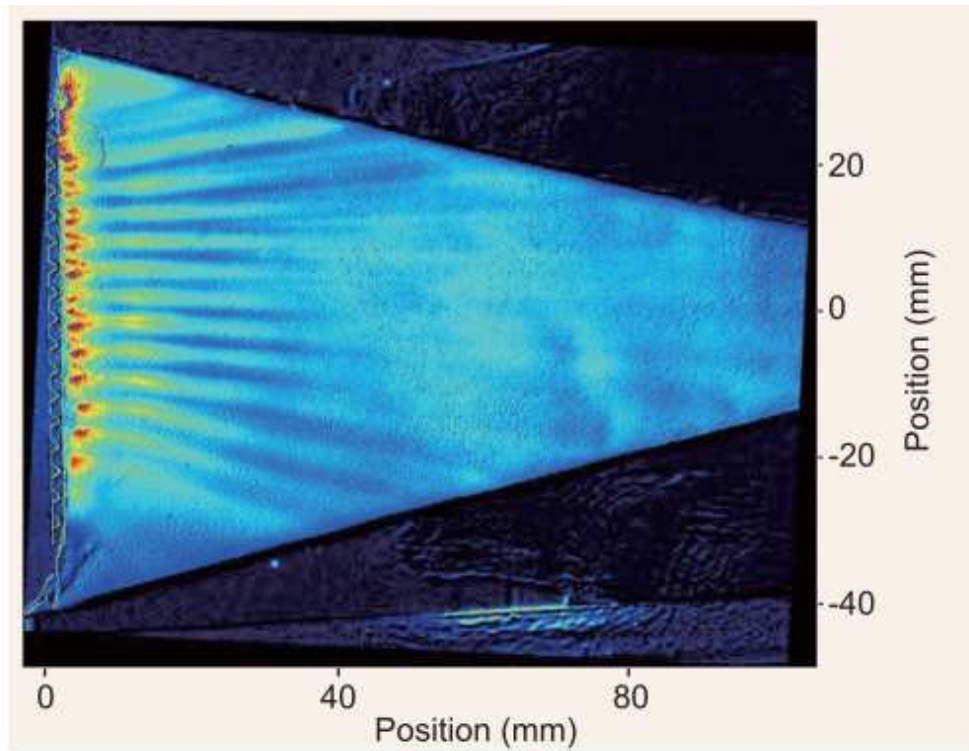

Fig. 20 Streaky temperature distribution over the concave surface of a scramjet model in a hypersonic wind tunnel, taken from Lee and Chen [190].

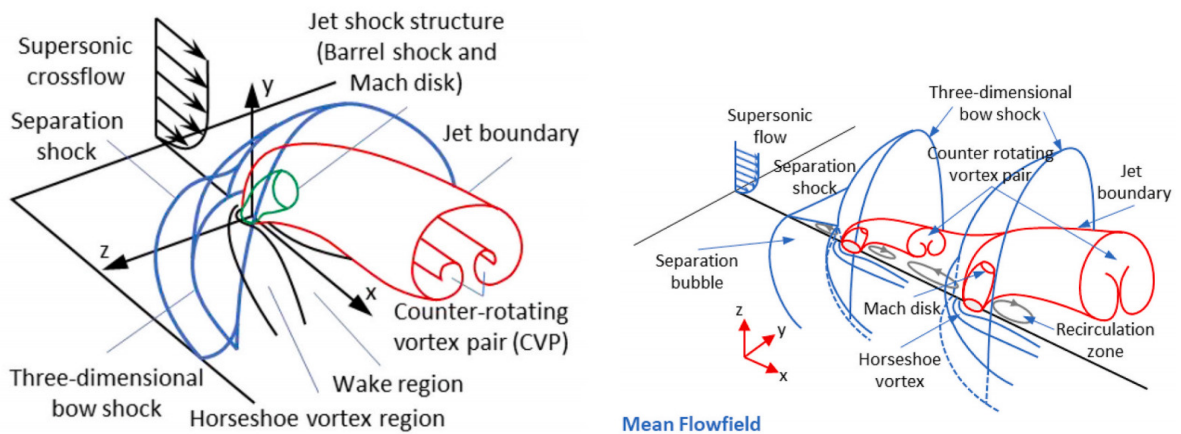

Fig. 21 Schematics of vortical structures in simple transverse jet injection (left) and dual transverse jet injection (right) systems. Taken from Liu et al. [221] with permission from Elsevier.

beyond the transition region through the fully-developed region is not discussed herein as it is out of the scope of our review.

### **A. Flows over spanwise-planar concave walls**

A systematic study of Görtler instability using DNS was first reported in a series of papers from the University of California, Los Angeles (UCLA) [223–228]. The UCLA group performed DNS of a Mach 15 flow over a blunt concave wedge. Their study focused on the receptivity in the leading-edge region of the wedge. Görtler vortices were introduced either by wall blowing and suction or by free-stream acoustic and vorticity disturbances. They found that wall transpiration generated spanwise disturbances that developed into Görtler modes. The receptivity simulations with free-stream disturbances imposed at the bow shock showed that Görtler vortices are mainly induced by free-stream steady vorticity waves, while they are hardly generated by traveling vorticity waves and fast acoustic waves. In addition to the receptivity study, the DNS study by the UCLA group included i) linearly growing Görtler vortices and the effect of surface curvature [223], ii) the nonlinear evolution of Görtler vortices and their interaction with the second Mack modes [224], and iii) the secondary instability of Görtler vortices [225]. Figure 22 shows cross-sectional contours of the streamwise velocity and the corresponding wall-normal velocity profiles for a Mach 15 flow over a blunt wedge with a concave surface. Inflectional profiles are more intense where the mushroom shapes of the Görtler vortices are more pronounced.

Li et al. [83] performed DNS to study the nonlinear development and initial breakdown of Görtler vortices for a Mach 6 similarity boundary layer over a concave plate with a radius of curvature of 20 meters. Their study considered Görtler vortices with three different spanwise wavelengths, including the most amplified Görtler mode and two subdominant modes. In each case, a Görtler mode was seeded via a specified roughness near the neutral point of the vortex mode. For all the three cases, the bell-shaped features were noted in the streamwise velocity contours at streamwise locations where the nonlinear Görtler vortices were nearly saturated. The well-known mushroom shaped contours were observed farther downstream, well into the saturation region.

Yu and Yuan [229] investigated the interaction between Görtler vortices and oblique second Mack modes in a Mach 6 flow using DNS. They found that Görtler vortices can act as a catalyst to promote the nonlinear growth of the Mack modes and subsequently lead to earlier transition to turbulence, even though Görtler instability alone may not dominate the transition process.

Chen et al. [112, 116] and Song et al. [87] investigated the secondary instability and breakdown of stationary Görtler vortices in a Mach 6.5 boundary layer over a planar concave wall by performing DNS. Their DNS results were compared with results from global stability analyses and PSE calculations. Consistent with the LST results discussed in §II.E, their DNS confirmed the development of first/second Mack modes into secondary modes in the presence of saturated nonlinear vortices. Chen et al. [230] performed DNS to study hypersonic concave-wall boundary-layer transition induced by blowing and suction with different frequencies. They found that the transition scenario changed from stationary to unsteady as an oblique mode eventually dominated the breakdown as the blowing/suction frequency increased from zero to 45 kHz. Secondary instability was recognized as an important ingredient for all the transition scenarios. The DNS results were also compared with those from global Floquet stability analysis and an overall good agreement between the two was achieved in the pre-breakdown stage.

Sescu et al. [231, 232] investigated the control of Görtler vortices in the Mach number range  $M_\infty = 1.5 - 7.5$  using DNS. Their control methodologies included wall transpiration and wall-heat transfer. Their DNS results showed that active control based on wall transpiration reduces both the wall-shear stress and the energy of the Görtler vortices, while wall cooling reduces the wall-shear stress but slightly increases the energy of Görtler vortices in supersonic and hypersonic regimes. Huang et al. [233] studied the control of Görtler vortices by streamwise grooves and found that these protrusions delayed the transition to turbulence.

### **B. Flows over flared cones**

Most of the DNS studies of high-speed boundary-layer transition over flared cones, for examples [88, 235–240], have been performed to compare numerical results with data obtained from experimental campaigns in quiet hypersonic wind tunnels, discussed in §III.D. The DNS results revealed that, because of the longitudinal concave curvature, high-speed boundary layers over flared cones at zero angle of attack support Görtler instability in addition to the first and second Mack waves. As a result, there are several potential routes to laminar-turbulent transition over flared cones, as discussed in Li et al. [234] and visualized in figure 23. These routes include (1) oblique mode breakdown of first Mack mode waves, (2) interactions between the axisymmetric second Mack mode and the oblique first Mack modes, (3) interactions between a pair of oblique second Mack modes, (4) interactions between the axisymmetric second Mack mode and Görtler modes, (5) secondary instability of the

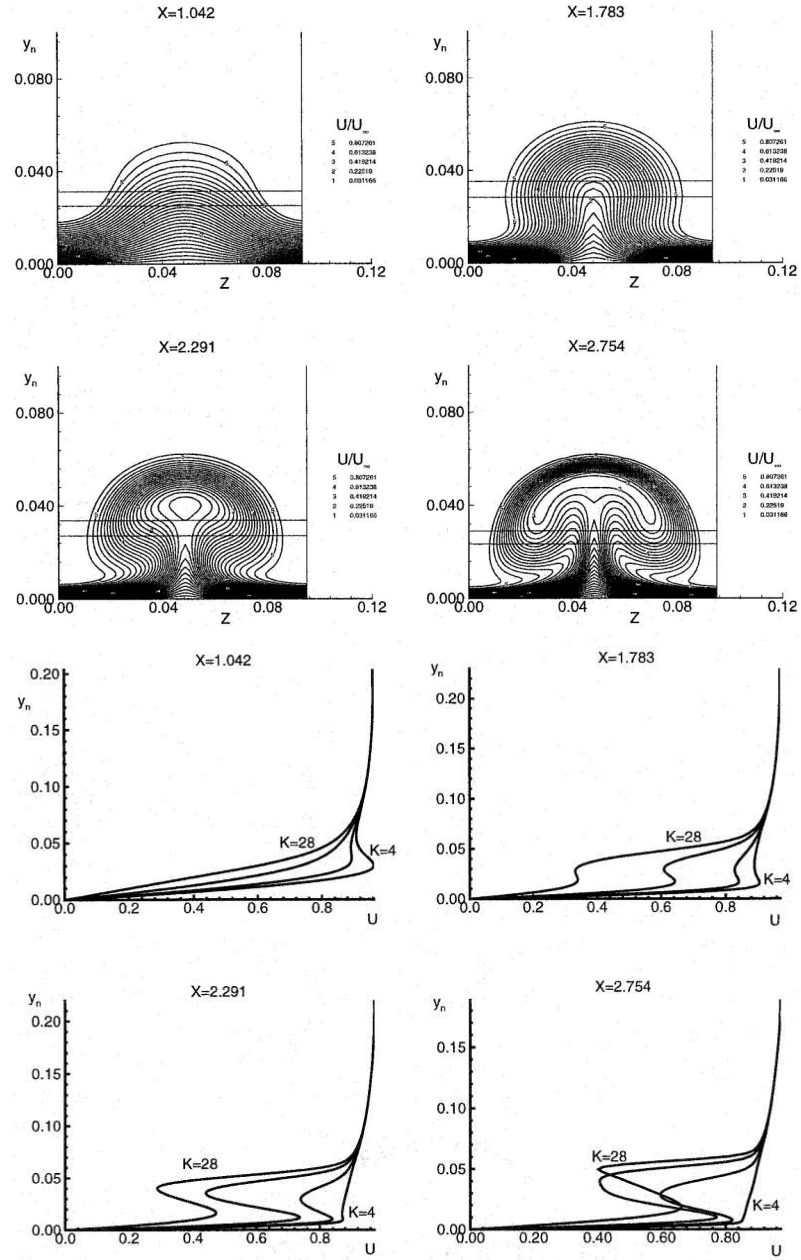

**Fig. 22** Streamwise velocity data of a flow over a concave surface at  $M_\infty = 15$ : contour lines (top two rows) and wall-normal profiles (bottom two rows). Taken from Whang and Zhong [225] by courtesy of Prof. Xiaolin Zhong.

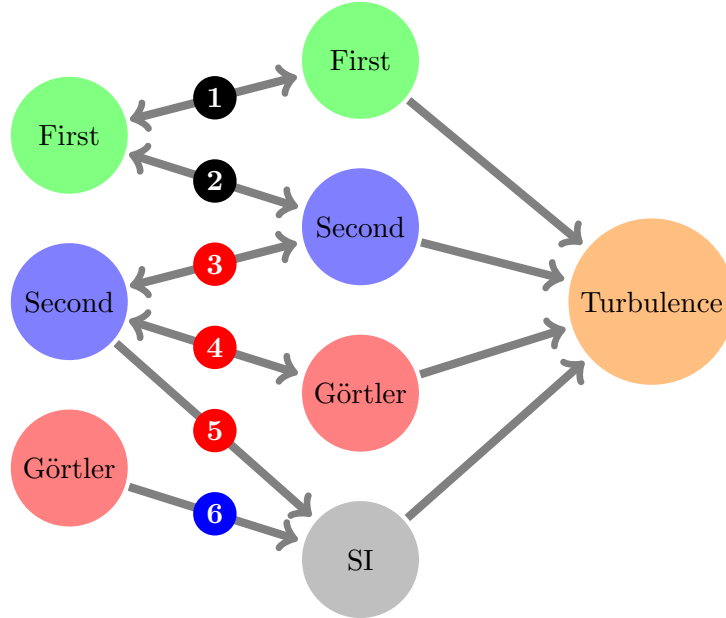
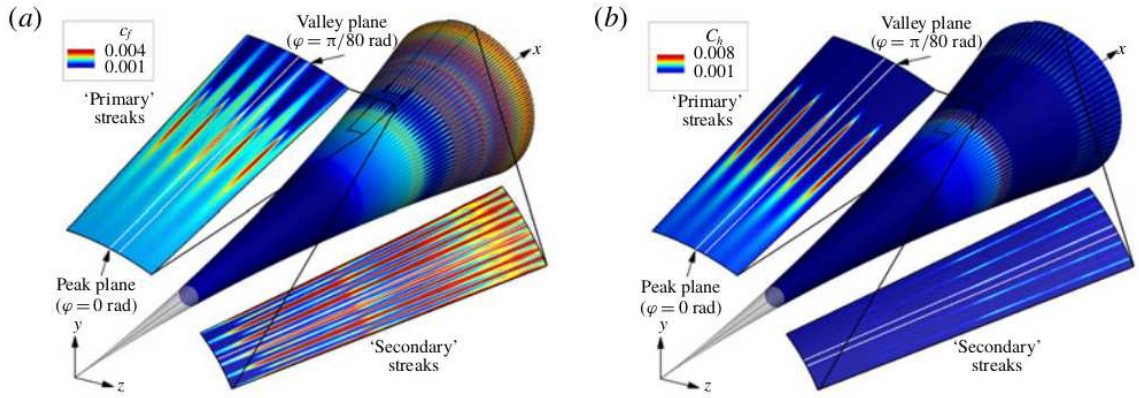

**Fig. 23** Transition routes in a hypersonic boundary layer over a flared cone [234]. SI denotes secondary instability. A single arrow indicates a stage of transition to turbulence and a double arrow indicates a nonlinear interaction. First, second and Görtler indicate the first Mack mode, the second Mack mode and Görtler vortices, respectively.

axisymmetric second Mack mode, and (6) high-frequency secondary instability of Görtler vortices. These routes to turbulence are however not well understood. For instance, analogous to the oblique second-mode transition, the interaction between unsteady Görtler modes with different frequencies and wavelengths needs to be clarified.

As for the experiments in §III.D, we limit our discussion to DNS studies on flared cones at zero angle of attack for which Görtler instability is likely to play a dominant role without the influence of cross flow. Pruett and Chang [235] studied forced boundary-layer transition over an axisymmetric flared cone using DNS and compared the results with those of the straight-cone counterpart. The flared-cone model and the flow conditions matched those of the experiments by Lachowicz et al. [192] in the Mach-6 Nozzle-Test-Chamber Facility at the NASA Langley Research Center. Transition was induced at the inflow boundary by periodic perturbations computed by solving the PSE and by disturbances obtained from physical experiments. Significant qualitative differences in the transition behaviors between cones with and without afterbody flare were reported. The Reynolds stress components, turbulent kinetic energy and turbulent Mach number all manifested maxima close to the wall in the flared-cone case, rather than near the critical layer in the straight-cone case. Large density fluctuations occurred at the wall in the flared-cone case and at the critical layer in the straight-cone case. Transition on the flared cone appeared to begin earlier and proceeded more gradually than on the straight cone, consistently with the experimental observations of Lachowicz et al. [192].

Laible and Fasel [236] and Laible [241] from the University of Arizona studied the effects of cone flare on the fundamental K-type breakdown by carrying out high-resolution DNS under the conditions of the NASA’s Mach-6 Nozzle-Test-Chamber Facility. Their DNS was initiated by a high-amplitude saturated two-dimensional second-mode wave and a small-amplitude pair of oblique secondary instability waves, all having the same frequency. Their DNS indicated that the modal interactions generate strong streaks and amplify the oblique modes, leading the flow to transition. These features are consistent with the predictions of the weakly nonlinear stability theory developed by Wu et al. [242]. Although the fundamental breakdown simulated by Laible and Fasel [236] and Laible [241] was controlled rather than being caused by a natural scenario, they observed streamwise vortices (referred to as ‘streaks’) on the cone surface that were similar to those observed in quiet-tunnel experiments [9, 180]. Fasel and coworkers [238, 243] also performed DNS to investigate the fundamental breakdown on another flared cone at Mach 6, with the cone geometry and flow conditions representative of the experiments in the BAM6QT at Purdue University. Similar



**Fig. 24 Time-averaged skin-friction coefficient and Stanton number for a flow at  $M_\infty = 6$  over a flared cone. Taken from Hader and Fasel [245] with permission from CUP.**

to the DNS of the flow over the NASA flared cone [236, 241], the breakdown to turbulence over the Purdue flared cone was simulated using a disturbance input with specified frequency and azimuthal wavenumber. The DNS confirmed the typical pattern of ‘hot’ and ‘cold’ streaks appearing, disappearing and then reappearing in the strongly nonlinear transition regime close to the final breakdown. Fasel et al. [243] further showed that the oblique breakdown can be another viable path to turbulence. They reported that this type of breakdown was only initiated by one pair of oblique second-Mack-mode disturbance waves with the same frequency and azimuthal wavenumbers, but with opposite sign. It was also shown that the nonlinear interactions during the oblique breakdown process can lead to the generation of strong stationary streamwise vortical modes [59, 244].

To further understand the underlying physical mechanisms of the streak development in the nonlinear stages of hypersonic transition observed in quiet-tunnel experiments, Hader and Fasel [246] performed additional DNS of the nonlinear flow breakdown over the Purdue flared cone. A random forcing was used at the inflow of the DNS domain to model the free-stream disturbance environment in the quiet tunnel. The DNS results with random forcing exhibited the same ‘primary’ and ‘secondary’ streak patterns as those observed in the controlled breakdown simulations of Hader and Fasel [238]. In particular, the spanwise spacing of the ‘primary’ streaks for the random forcing case was identical to the spacing obtained from the controlled simulation. This result suggested that the mechanisms observed in the controlled case were likely to be the same as those leading to laminar-turbulent transition in the natural transition scenario observed in the BAM6QT. The DNS results reported in Hader and Fasel [245] and Chynoweth et al. [9] provided further evidence that the streaks are generated by the nonlinear interaction of the two-dimensional saturated second Mack mode and the secondary disturbance waves. Figure 24 shows the skin-friction coefficient and the Stanton number for the Mach 6 flow computed by Hader and Fasel [245]. The striations are distinct evidence of the nonlinear streaks and the similarity with the streaks observed experimentally, shown in figure 14, is evident. Hader and Fasel [240] further explored transition control over a Mach 6 flared cone using steady surface blowing and suction. The DNS results demonstrated that the development of hot streaks can be successfully delayed with a transition control technique that focuses on the nonlinear stage.

Fasel and coworkers provided strong evidence that the nonlinear modal interactions detected during both the second-Mack-mode fundamental breakdown and the oblique breakdown can lead to the generation of streamwise-aligned streaks that resembled the ‘hot-cold-hot’ streaks observed in the experiments conducted at the NASA and Purdue facilities. They also mentioned that the transition routes caused by nonlinear interactions between the second Mack mode and Görtler modes cannot be excluded. Indeed, the flared-cone experiments in the Mach 6 Quiet tunnel at Peking University [88] showed that streak-like structures have the same spanwise wavelength of the linear Görtler mode, which suggests the relevance of Görtler instability. Their experimental data also revealed that unsteady streamwise streaks are likely to arise in addition to the steady streamwise streaks studied by DNS. These results suggest that an understanding of the receptivity process is required to ultimately determine the mechanism of streak formation on flared cones.

Li et al. [8, 117, 239] used DNS and spatial secondary instability analysis to investigate finite-amplitude Görtler vortices and their secondary instability over a Mach 6 straight cone with an aft concave section at zero angle of attack. Unlike most previous DNS studies that used a controlled disturbance input, their study aimed to investigate fully realizable Görtler instability, triggered by an azimuthally periodic array of surface protuberances. The motivation was a potential application for

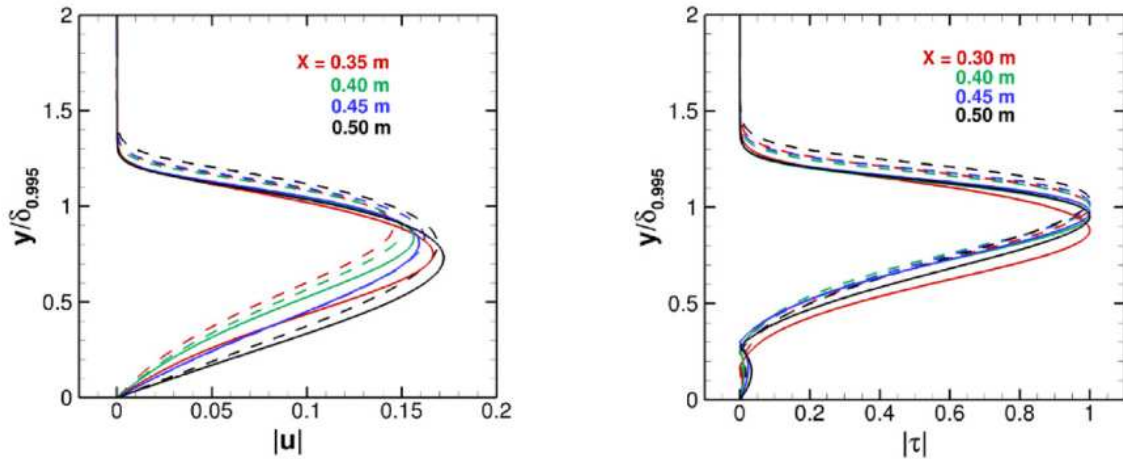

**Fig. 25** Wall-normal velocity and temperature profiles of Görtler vortices over a flared cone at  $M_\infty = 6$ , taken from Li et al. [8] with permission from Springer. The solid lines denote data from PSE calculations, while the dashed lines represent DNS data.

controlling transition along the wall of a hypersonic wind-tunnel nozzle. The DNS results confirmed the existence of fully developed mushroom structures in the hypersonic regime when the amplitude of the vortices was sufficiently large, in addition to bell-shaped structures. The important role played by the secondary instability modes originated from the Mack mode instability during the nonlinear breakdown process was highlighted. Figure 25 shows wall-normal velocity and temperature profiles of Görtler vortices over a flared cone at  $M_\infty = 6$ , extracted from the PSE calculations and DNS of Li et al. [8]. The temperature profiles are closer to the free stream than the velocity profiles, a feature shared by Görtler vortices excited by free-stream disturbances [16].

Hollender et al. [247] performed DNS for the same flared-cone geometry of Li et al. [117, 239]. Görtler vortices were excited by steady upstream distributed vortical disturbances with a spectrum of azimuthal wavenumbers. The three velocity components were prescribed at a fixed streamwise location by a simple mathematical relationship that allowed varying the azimuthal wavenumber. These imposed vortical perturbations mimicked the effect of distributed random roughness, rather than vortex generators with a specific azimuthal spacing. Their calculated flow fields revealed the presence of selectively amplified streamwise streaks with a distinct azimuthal wavelength, that caused significant base-flow modifications and eventually led to laminar-turbulent transition.

In summary, the existing studies of compressible boundary-layer transition over flared cones have shown the coexistence of multiple modes of instability, namely first/second Mack mode and Görtler vortices. The nonlinear interactions among the various instability modes complicates the transition process considerably. Given that multiple laminar-turbulent transition routes exist depending on the relative initial amplitude of each mode, the entrainment of the free-stream disturbances into a laminar boundary layer (i.e., the receptivity stage) can play a key role in the accurate prediction of transition. However, most of the existing DNS have excluded the leading edge region of the cone and bypassed the receptivity in the proximity of the leading edge. Balakumar and his coworkers [248] were among the first to perform DNS of the receptivity of a boundary layer over a flared cone to acoustic waves, resulting in the excitation of the second Mack mode. Theoretical analyses suggest that Görtler vortices are mostly receptive to steady or low-frequency free-stream disturbances [81, 100]. However, no DNS have been performed to study the receptivity of a supersonic boundary layer over a flared cone to free-stream disturbances for the excitation of Görtler vortices. As the receptivity theory dictates that the external perturbations and the disturbances within a boundary layer cannot be treated independently for the prediction of transition over flared cones, additional DNS are needed to simulate all the transition stages, starting from the receptivity process and up to the fully turbulent flow. It is essential to exercise caution when trying to explain the emergence of streak-like structures or streamwise vortices over flared cones, such as those observed in the quiet hypersonic tunnel experiments. The risk may be to attribute all the streak-like structures and the associated enhanced heat transfer solely to Görtler instability, while excluding alternative mechanisms such as the nonlinear modal interactions active in the second-Mack-mode fundamental breakdown and oblique breakdown, as reported by Fasel and coworkers and discussed in Wu [59].

### C. Flows over other geometries

In addition to concave spanwise-planar walls and flared cones, DNS studies on Görtler vortices have been performed for other concave-wall geometries including wind-tunnel nozzles and ramp compression corners. Li et al. [83] performed DNS of the axisymmetric flow field inside the Ludwieg tube of the Boeing/AFOSR Mach 6 wind tunnel at Purdue University to study transition in the nozzle-wall boundary layer. Their DNS domain included a long portion of the concave surface of the nozzle wall between the throat and the test section, wherein the growth of Görtler vortices has a direct impact on the flow quality. Their DNS identified multiple families of unstable secondary eigenmodes. The nonlinear evolution of the linearly most amplified primary Görtler mode led to distinct bell-shaped structures, which sustained intense secondary instabilities and caused the onset of transition. The most unstable linear secondary instability mode was anti-symmetric with respect to the symmetry line of the Görtler vortices. As this anti-symmetric secondary instability mode developed downstream, nonlinear effects set in and caused sinuous motions of the Görtler vortices. With higher harmonics of the secondary instability becoming significant, the bell structures of the Görtler vortices disappeared and the unsteady fluctuations progressively moved closer to the wall, leading to a higher wall-shear stress.

DNS were also performed by Hildebrand et al. [249] to investigate flow instability created by an oblique shock wave impinging on a Mach 5.92 laminar boundary layer. The centrifugal instability region was determined by using the Rayleigh inviscid discriminant. Their DNS results and global stability analysis suggested that the centrifugal instability plays no role in the upstream self-sustaining mechanism of the global mode, but it may act as an amplifier for the streaks farther downstream.

Recent DNS papers have focused on the hypersonic flows over compression ramps [250–258]. As already discussed in the presentation of the experimental studies in §III.E, a main concern is the role of centrifugal effects on the instability of separation bubbles, emerging streaks, and ensuing transition. Cao et al. [258] urged to investigate further the influence of upstream disturbances on the formation of streamwise streaks and the related transition process, in line with the relevance of the receptivity theory discussed in §II.D. The impact of the upstream disturbances on the separation-bubble instability and its relation with the centrifugal instability also merit further attention.

## V. Prospects and challenges

Despite the vast literature on compressible Görtler vortices, there remain several challenges in this research area, related to the fundamental understanding of these vortical structures, such as their creation and their role in transition to turbulence, and their prediction and control in industrial engineering systems, with the objective of an improved energetic performance.

### A. Receptivity and transition prediction

The prediction of transition to turbulence in compressible boundary layers over concave surfaces is a pressing problem because the performance of high-speed vehicles, turbomachinery and hypersonic wind tunnels depends crucially on whether the flow is laminar or turbulent. Görtler vortices certainly play a central role in laminar-turbulent transition in these engineering systems and therefore further coordinated fundamental and applied efforts in the area of transition prediction are highly desirable.

For compressible boundary layers in complex geometries, the formation, evolution and secondary instability of Görtler vortices are influenced by many factors, including free-stream disturbances, wall roughness and vibration, streamwise curvature, cross flow, flow separation, shock-wave/boundary-layer interactions and real-gas effects at high Mach numbers. The role of receptivity is therefore paramount because a cardinal aim is to evince how external perturbing agents trigger instability modes inside the boundary layer and provoke the breakdown to turbulence. The mathematical approach, largely based on perturbation and asymptotic analysis, has proven to be an indispensable tool for receptivity studies. However, it has limitations towards the ultimate objective of transition prediction because the final stages of nonlinear breakdown to turbulence cannot be described by the current mathematical frameworks, which include linear stability theory, initial-value theory, and initial-boundary-value theory. The next era of boundary-layer transition studies should thus witness intense collaborative endeavors, where mathematical techniques, numerical simulations and controlled experiments form a joined and interactive methodology.

A major challenge for experimentalists is to measure free-stream disturbances accurately as the flow reaches hypersonic conditions, in particular the amplitude, spectrum, and wavelengths of velocity, entropy and acoustic disturbances [259]. Even more difficult, and equally important, is to obtain precise velocity and temperature profiles within a compressible boundary layer, for example of the quality of those reported by Graziosi and Brown [260] and Craig and Saric [261]. Experimental data of this highest level could be used as input for nonlinear receptivity theory to predict how compressible Görtler vortices form

and grow inside a boundary layer. The subsequent step would be to utilize the nonlinear receptivity results in support of the numerical solution of the full compressible Navier-Stokes equations to compute the location and extent of the transition region with accuracy, and to correlate the characteristics of the external disturbance environment with those of the transitional flow. Such a comprehensive methodology would lead to an improved understanding of the physical mechanism and to a quantitative comparison with experiments. It could also aid the construction of advanced transition models where external perturbations could be included, as powerful alternatives to the  $e^N$  method.

## **B. Flow control**

### *Wind-tunnel nozzles*

As amply discussed in §III.C and in the references therein, one of the most serious problems in hypersonic aerodynamics is to maintain a ‘quiet’ free-stream environment in order to be able to faithfully reproduce flight conditions in the test section. It is therefore highly desirable to preserve laminar boundary layers over the tunnel nozzle to avoid aeroacoustic noise production by wall turbulence. As Görtler vortices exist on the concave portions of the nozzle surface, more research efforts should be directed toward controlling these vortices, for example by distributed wall transpiration or wall-heat transfer. Present techniques focus on suction slots at the tunnel throat and on longer nozzles. The control of Görtler vortices would render hypersonic wind tunnels more reliable and common, as only a few ‘quiet’ tunnels are in operation (in 2015, there were only three such tunnels [19]).

### *Hypersonic vehicles*

The suppression of Görtler vortices and a delay of transition to turbulence are also desirable over hypersonic vehicles, such as those discussed in §III.G. Extended laminar boundary layers would translate directly to a reduction of friction drag. As discussed in §II.F, studies on the passive control of compressible Görtler vortices are limited [122]. It has not been fully verified whether subharmonic disturbances generated by wall roughness can suppress the Görtler instability to achieve transition delay, similar to the roughness-induced transition delay in the presence of cross-flow vortices [262]. It would be interesting to verify the effectiveness of the control strategy used by Ren et al. [120] if a realistic receptivity formalism synthesizing the formation of streaks and Görtler vortices were utilized, such as those of Marensi et al. [48] and Viaro and Ricco [16], instead of the optimal-growth approach, which completely neglects the external triggering agents responsible for Görtler instability, i.e., free-stream disturbances, wall vibrations and wall roughness. A related research topic is the precise quantification of the atmospheric disturbance environment through which hypersonic vehicles fly, as a key ingredient for theoretical and numerical receptivity studies and as benchmark for wind-tunnel free-stream flows.

### *Wall-heat transfer*

There is certainly need for more research studies on the effect of wall-heat transfer on compressible Görtler vortices because of the potential for flow control. Some controversy still exists in this area. Results from the linearized stability approach, discussed in §II.B, are contradictory on the influence of wall cooling and on whether the spanwise wavelength plays a role. Further calculations, by Fu and Hall [65] and more recently by Sescu et al. [231], indicate that wall cooling is destabilizing and the wall-shear stress is initially reduced. The experimental evidence on the influence of wall-heat transfer on Görtler vortices is even more scarce. As discussed in §III, experimental studies [155, 175] show that wall heating renders the flow more stable and can lead to a larger transitional Reynolds number. This effect was primarily attributed to an increase in the boundary-layer thickness and to a corresponding decrease in the sensitivity of the boundary layer to wall roughness. Conversely, when the boundary layer becomes thinner because of wall cooling or wall suction, the relative residual roughness may enhance the growth of Görtler vortices [157].

## **Acknowledgments**

We would like to thank the Referees and Dr Elena Marensi for the useful comments. DX is indebted to Professor Xuesong Wu from Imperial College London for leading him into the field of Görtler instability. The authors thank Professor John Schmisser for pointing out some papers by Professor Graham V. Candler and co-workers. DX and PR were supported by EPSRC (Grant No. EP/T01167X/1) and LD was supported by the U.S. National Science Foundation (under grant CBET 2001127, managed by Dr Ronald Joslin). PR would also like to thank the financial aid by the U.S. Air Force through AFOSR grant FA8655-21-1-7008 (International Program Office - Dr Douglas Smith). The views and conclusions contained herein are those of the authors and should not be interpreted as necessarily representing the official policies or endorsements, either expressed or implied, of the funding agencies or the U.S. Government. The authors report no conflict of interest.

## References

- [1] Schneider, S. P., "Flight data for boundary-layer transition at hypersonic and supersonic speeds," *J. Spacecr. Rockets*, Vol. 36, No. 1, 1999, pp. 8–20. <https://doi.org/10.2514/2.3428>.
- [2] Ren, Z., Wang, B., Xiang, G., Zhao, D., and Zheng, L., "Supersonic spray combustion subject to scramjets: Progress and challenges," *Prog. Aerosp. Sci.*, Vol. 105, 2019, pp. 40–59. <https://doi.org/10.1016/j.paerosci.2018.12.002>.
- [3] Sun, Y., and Smith, H., "Review and prospect of supersonic business jet design," *Prog. Aerosp. Sci.*, Vol. 90, 2017, pp. 12–38. <https://doi.org/10.1016/j.paerosci.2016.12.003>.
- [4] Schneider, S. P., "Development of hypersonic quiet tunnels," *J. Space. Rock.*, Vol. 45-4, 2008, pp. 641–664. <https://doi.org/10.2514/1.34489>.
- [5] Fedorov, A., "Transition and stability of high-speed boundary layers," *Annu. Rev. Fluid Mech.*, Vol. 43, 2011, pp. 79–95. <https://doi.org/10.1146/annurev-fluid-122109-160750>.
- [6] Mack, L., "Boundary-layer linear stability theory," *Special Course on Stability and Transition of Laminar flow. AGARD Report 709*, 1984, pp. 1–81.
- [7] Liu, J., Marensi, E., and Wu, X., "Effects of streaky structures on the instability of supersonic boundary layers," *IUTAM Symposium on Laminar Turbulent Transition*, 2019. [https://doi.org/10.1007/978-3-030-67902-6\\_51](https://doi.org/10.1007/978-3-030-67902-6_51).
- [8] Li, F., Choudhari, M., and Paredes, P., "Secondary instability of Görtler vortices in hypersonic boundary layer over an axisymmetric configuration," *Theor. Comput. Fluid Dyn.*, Vol. 36, No. 2, 2022, pp. 205–235. <https://doi.org/10.1007/s00162-021-00599-3>.
- [9] Chynoweth, B. C., Schneider, S. P., Hader, C., Fasel, H., Batista, A., Kuehl, J., Juliano, T. J., and Wheaton, B. M., "History and progress of boundary-layer transition on a Mach-6 flared cone," *J. Spacecr. Rockets*, Vol. 56, No. 2, 2019, pp. 333–346. <https://doi.org/10.2514/1.a34285>.
- [10] Mayle, R. E., "The 1991 IGTI Scholar Lecture: The Role of Laminar-Turbulent Transition in Gas Turbine Engines," *ASME J. Turbomach.*, Vol. 113, 1991, pp. 509–537. <https://doi.org/10.1115/1.2929110>.
- [11] Görtler, H., "Instabilität laminarer Grenzschichten an konkaven Wänden gegenüber gewissen dreidimensionalen Störungen," *Z. Angew. Math. Mech.*, Vol. 21, No. 4, 1941, pp. 250–252. <https://doi.org/10.1002/zamm.19410210408>.
- [12] Hall, P., "The linear development of Görtler vortices in growing boundary layers," *J. Fluid Mech.*, Vol. 130, 1983, pp. 41–58. <https://doi.org/10.1017/s0022112083000968>.
- [13] Bradshaw, P., "Effects of streamline curvature on turbulent flow." Tech. rep., Advisory group for aerospace research and development, Paris (France), 1973.
- [14] Floryan, J. M., "On the Görtler instability of boundary layers," *Prog. Aerosp. Sci.*, Vol. 28, No. 3, 1991, pp. 235–271. [https://doi.org/10.1016/0376-0421\(91\)90006-p](https://doi.org/10.1016/0376-0421(91)90006-p).
- [15] Wu, X., Zhao, D., and Luo, J., "Excitation of steady and unsteady Görtler vortices by free-stream vortical disturbances," *J. Fluid Mech.*, Vol. 682, 2011, pp. 66–100. <https://doi.org/10.1017/jfm.2011.224>.
- [16] Viaro, S., and Ricco, P., "Compressible unsteady Görtler vortices subject to free-stream vortical disturbances," *J. Fluid Mech.*, Vol. 867, 2019, pp. 250–299. <https://doi.org/10.1017/jfm.2019.83>.
- [17] Flaherty, W., and Austin, J., "Effect of concave wall geometry on heat transfer in hypersonic boundary layers," *AIAA Paper*, 2010, pp. 2010–4986. <https://doi.org/10.2514/6.2010-4986>.
- [18] Beckwith, I., Harvey, W., Harris, J., and Holley, B., "Control of supersonic wind-tunnel noise by laminarization of nozzle-wall boundary layer," *NASA Tech. Memorandum*, Vol. X-2879, 1973.
- [19] Schneider, S. P., "Developing mechanism-based methods for estimating hypersonic boundary-layer transition in flight: The role of quiet tunnels," *Progr. Aerosp. Sc.*, Vol. 72, 2015, pp. 17–29. <https://doi.org/10.1016/j.paerosci.2014.09.008>.
- [20] Hall, P., "Görtler vortices in growing boundary layers: the leading edge receptivity problem, linear growth and the nonlinear breakdown stage," *Mathematika*, Vol. 37, No. 74, 1990, pp. 151–189. <https://doi.org/10.1112/s0025579300012894>.
- [21] Saric, W. S., "Görtler vortices," *Annu. Rev. Fluid Mech.*, Vol. 26, No. 1, 1994, pp. 379–409. <https://doi.org/10.1146/annurev.fl.26.010194.002115>.

- [22] Rayleigh, L., “On the dynamics of revolving fluids,” *Proc. R. Soc. Lond. A*, Vol. 93, No. 648, 1917, pp. 148–154. <https://doi.org/10.1098/rspa.1917.0010>.
- [23] von Kármán, T., “Some aspects of the turbulence problem,” *Proc. 4th Int. Congr. for Applied Mech., Cambridge, England, Proc.*, 1934, pp. 54–91.
- [24] Xu, D., Zhang, Y., and Wu, X., “Nonlinear evolution and secondary instability of steady and unsteady Görtler vortices induced by free-stream vortical disturbances,” *J. Fluid Mech.*, Vol. 829, 2017, pp. 681–730. <https://doi.org/10.1017/jfm.2017.572>.
- [25] Ren, J., and Fu, S., “Secondary instabilities of Görtler vortices in high-speed boundary layer flows,” *J. Fluid Mech.*, Vol. 781, 2015, pp. 388–421. <https://doi.org/10.1017/jfm.2015.490>.
- [26] Taylor, G. I., “Stability of a viscous liquid contained between two rotating cylinders,” *Phil. Trans. R. Soc. Lond. A*, Vol. 223, No. 605-615, 1923, pp. 289–343. <https://doi.org/10.1098/rspa.1923.0013>.
- [27] Aihara, Y., *Stability of the Compressible Boundary Layer along a Curved Wall under Görtler-Type Disturbances*, Aeronautical Research Institute, Tokyo Imperial University, 1961.
- [28] Hammerlin, G., “Über die Stabilität einer kompressiblen Strömung längs einer konkaven Wand bei verschiedenen Wandtemperaturverhältnissen,” *Deutsche Versuchsanstalt für Luftfahrt*, No. 176, 1961.
- [29] Kobayashi, R., and Kohama, Y., “Taylor–Görtler instability of compressible boundary layers,” *AIAA J.*, Vol. 15, No. 12, 1977, pp. 1723–1727. <https://doi.org/10.2514/3.7478>.
- [30] Kahawita, R. A., and Meroney, R. N., “Longitudinal vortex instabilities in laminar boundary layers over curved heated surfaces,” *Phys. Fluids*, Vol. 17, No. 9, 1974, pp. 1661–1666. <https://doi.org/10.1063/1.1694952>.
- [31] Kahawita, R., and Meroney, R., “The influence of heating on the stability of laminar boundary layers along concave curved walls,” *J. Appl. Mech.*, Vol. 44, No. 1, 1977, pp. 11–17. <https://doi.org/10.1115/1.3423975>.
- [32] Ricco, P., Tran, D.-L., and Ye, G., “Wall heat transfer effects on Klebanoff modes and Tollmien-Schlichting waves in a compressible boundary layer,” *Phys. Fluids*, Vol. 21, No. 024106, 2009. <https://doi.org/10.1063/1.3054155>.
- [33] Ricco, P., Shah, D., and Hicks, P. D., “Compressible laminar streaks with wall suction,” *Phys. Fluids*, Vol. 25, No. 054110, 2013. <https://doi.org/10.1063/1.4807066>.
- [34] El-Hady, N. M., and Verma, A. K., “Growth of Görtler vortices in compressible boundary layers along curved surfaces,” *AIAA Paper*, Vol. 81-1278, 1981. <https://doi.org/10.2514/6.1981-1278>.
- [35] El-Hady, N. M., and Verma, A. K., “Goertler instability in compressible boundary layers along curved surfaces with suction and cooling,” *NASA Contractor Report 3544*, 1982. <https://doi.org/10.2514/6.1982-1010>.
- [36] Goglia, G. L., and Verma, A. K., “On higher eigenstates of Goertler instability in compressible flow,” *NACA-CR-169480*, 1982.
- [37] El-Hady, N. M., and Verma, A. K., “Görtler Instability of Compressible Boundary Layers,” *AIAA J.*, Vol. 22, No. 10, 1984, pp. 1354–1355. <https://doi.org/10.2514/3.48574>.
- [38] El-Hady, N. M., and Verma, A. K., “Instability of compressible boundary layers along curved walls with suction or cooling,” *AIAA J.*, Vol. 22, No. 2, 1984, pp. 206–213. <https://doi.org/10.2514/3.8369>.
- [39] Floryan, J., and Saric, W., “Stability of Görtler vortices in boundary layers,” *AIAA Paper*, 1979, pp. 79–1479. <https://doi.org/10.2514/6.1979-1497>.
- [40] Malik, M. R., “Prediction and control of transition in supersonic and hypersonic boundary layers,” *AIAA J.*, Vol. 27, No. 11, 1989, pp. 1487–1493. <https://doi.org/10.2514/3.10292>.
- [41] Ren, J., and Fu, S., “Multiple Görtler modes in compressible boundary layer flows,” *AIAA Paper*, 2012, pp. 2012–3078. <https://doi.org/10.2514/6.2012-3078>.
- [42] Ren, J., and Fu, S., “Competition of the multiple Görtler modes in hypersonic boundary layer flows,” *Sci. China Phys. Mech. Astron.*, Vol. 57, No. 6, 2014, pp. 1178–1193. <https://doi.org/10.1007/s11433-014-5454-9>.
- [43] Ren, J., and Fu, S., “Study of the discrete spectrum in a Mach 4.5 Görtler flow,” *Flow, Turbul. Combust.*, Vol. 94, No. 2, 2015, pp. 339–357. <https://doi.org/10.1007/s10494-014-9575-z>.

- [44] Ren, J., and Fu, S., “Nonlinear development of the multiple Görtler modes in hypersonic boundary layer flows,” *AIAA Paper*, 2013, pp. 2013–2467. <https://doi.org/10.2514/6.2013-2467>.
- [45] Hall, P., “The nonlinear development of Görtler vortices in growing boundary layers,” *J. Fluid Mech.*, Vol. 193, 1988, pp. 243–266. <https://doi.org/10.1017/s0022112088002137>.
- [46] Kemp, N., “The laminar three-dimensional boundary layer and a study of the flow past a side edge,” *MSc Thesis, Cornell University*, 1951.
- [47] Leib, S. J., Wundrow, D. W., and Goldstein, M. E., “Effect of free-stream turbulence and other vortical disturbances on a laminar boundary layer,” *J. Fluid Mech.*, Vol. 380, 1999, pp. 169–203. <https://doi.org/10.1017/s0022112098003504>.
- [48] Marensi, E., Ricco, P., and Wu, X., “Nonlinear unsteady streaks engendered by the interaction of free-stream vorticity with a compressible boundary layer,” *J. Fluid Mech.*, Vol. 817, 2017, pp. 80–121. <https://doi.org/10.1017/jfm.2017.88>.
- [49] Hall, P., and Malik, M., “The growth of Görtler vortices in compressible boundary layers,” *J. Eng. Math.*, Vol. 23, No. 3, 1989, pp. 239–251. <https://doi.org/10.1007/bf02383571>.
- [50] Hall, P., and Fu, Y., “On the Görtler vortex instability mechanism at hypersonic speeds,” *Theor. Comp. Fluid Dyn.*, Vol. 1, No. 3, 1989, pp. 125–134. <https://doi.org/10.1007/bf00417916>.
- [51] Hall, P., and Malik, M., “The growth of Görtler vortices in compressible boundary layers,” *NASA Rep. 87-27961*, 1987.
- [52] Dando, A., “The inviscid compressible Görtler problem in three-dimensional boundary layers,” *Theor. Comp. Fluid Dyn.*, Vol. 3, No. 5, 1992, pp. 253–265. <https://doi.org/10.1007/bf00717643>.
- [53] Spall, R. E., and Malik, M. R., “Goertler vortices in supersonic and hypersonic boundary layers,” *Phys. Fluids A*, Vol. 1, No. 11, 1989, pp. 1822–1835. <https://doi.org/10.1063/1.857508>.
- [54] Wadey, P. D., “On the linear development of Görtler vortices in compressible boundary layers,” *Euro. J. Fluid Mech. B/Fluids*, Vol. 11, No. 6, 1992, pp. 705–717.
- [55] Dando, A. H., and Seddougui, S. O., “The compressible Görtler problem in two-dimensional boundary layers,” *IMA J. Appl. Math.*, Vol. 51, No. 1, 1993, pp. 27–67. <https://doi.org/10.1093/imamat/51.1.27>.
- [56] Fu, Y., Hall, P., and Blackaby, N., “On the Görtler instability in hypersonic flows: Sutherland law fluids and real gas effects,” *Phil. Trans. R. Soc. A*, Vol. 342, No. 1665, 1993, pp. 325–377. <https://doi.org/10.1098/rsta.1993.0025>.
- [57] Fu, Y., and Hall, P., “Crossflow effects on the growth rate of inviscid Görtler vortices in a hypersonic boundary layer,” *J. Fluid Mech.*, Vol. 276, 1994, pp. 343–367. <https://doi.org/10.1017/s0022112094002594>.
- [58] Stuart, J. T., “Nonlinear stability theory,” *Annu. Rev. Fluid Mech.*, Vol. 3, 1971, pp. 347–370. <https://doi.org/10.1146/annurev.fl.03.010171.002023>.
- [59] Wu, X., “Nonlinear theories for shear flow instabilities: Physical insights and practical implications,” *Annu. Rev. Fluid Mech.*, Vol. 51, 2019, pp. 451–485. <https://doi.org/10.1146/annurev-fluid-122316-045252>.
- [60] Fu, Y., and Hall, P., “Nonlinear development and secondary instability of Görtler vortices in hypersonic flows,” *NASA Rep. 91-39*, University of Manchester, 1991.
- [61] Fu, Y., and Hall, P., “Nonlinear development and secondary instability of large-amplitude Görtler vortices in hypersonic boundary layers,” *Eur. J. Mech. B/Fluids*, Vol. 11, No. 4, 1992.
- [62] Hall, P., “On the non-linear evolution of Görtler vortices in non-parallel boundary layers,” *IMA J. Appl. Math.*, Vol. 29, No. 2, 1982, pp. 173–196. <https://doi.org/10.1093/imamat/29.2.173>.
- [63] Hall, P., and Lakin, W. D., “The fully nonlinear development of Görtler vortices in growing boundary layers,” *Proc. R. Soc. London A*, Vol. 415, No. 1849, 1988, pp. 421–444. <https://doi.org/10.1098/rspa.1988.0021>.
- [64] Wadey, P. D., “On the nonlinear development of Görtler vortices in a compressible boundary layer,” *Studies in Appl. Math.*, Vol. 85, No. 4, 1991, pp. 317–341. <https://doi.org/10.1002/sapm1991854317>.
- [65] Fu, Y., and Hall, P., “Effects of Görtler vortices, wall cooling and gas dissociation on the Rayleigh instability in a hypersonic boundary layer,” *J. Fluid Mech.*, Vol. 247, 1993, pp. 503–525. <https://doi.org/10.1017/s0022112093000540>.

- [66] Lipatov, I. I., and Bogolepov, V. V., “Görtler vortices development in hypersonic flows,” *AIAA Paper*, Vol. 2014, 1997. <https://doi.org/10.2514/6.1997-2014>.
- [67] Bogolepov, V. V., and Lipatov, I. I., “Effect of compressibility on the development of Taylor-Görtler vortices at high Reynolds numbers,” *Fluid Dyn.*, Vol. 32, No. 1, 1997, pp. 28–38. <https://doi.org/10.1007/bf02697934>.
- [68] Bogolepov, V. V., “Investigation of the spectrum of short-wave Görtler vortices in a gas,” *J. Applied Mech. Techn. Phys.*, Vol. 39, No. 5, 1998, pp. 710–718. <https://doi.org/10.1007/bf02468041>.
- [69] Bogolepov, V. V., “Asymptotic analysis of the structure of long-wave Görtler vortices in a hypersonic boundary layer,” *J. Appl. Mech. Tech. Phys.*, Vol. 42, No. 5, 2001, pp. 773–785. <https://doi.org/10.1023/A:1017988325305>.
- [70] Elliott, J. W., and Bassom, A. P., “The effect of wall cooling on compressible Görtler vortices,” *Euro. J. Fluid Mech. B/Fluids*, Vol. 19, No. 1, 2000, pp. 37–68. [https://doi.org/10.1016/s0997-7546\(00\)00106-0](https://doi.org/10.1016/s0997-7546(00)00106-0).
- [71] Es-Sahli, O., Sescu, A., Afsar, M., Hattori, Y., and Hirota, M., “Effect of wall cooling or heating on streaks in high-speed boundary layers,” *AIAA Paper*, 2021, pp. 2021–0853. <https://doi.org/10.2514/6.2021-0853>.
- [72] Es-Sahli, O., Sescu, A., Afsar, M., and Hattori, Y., “Investigation of Görtler vortices in high-speed boundary layers via an efficient numerical solution to the non-linear boundary region equations,” *Theor. Comp. Fluid Dyn.*, Vol. 36, No. 2, 2022, pp. 237–249. <https://doi.org/10.1007/s00162-021-00576-w>.
- [73] Es-Sahli, O., Sescu, A., Koshuriyan, M. Z. A., Hattori, Y., and Hirota, M., “Lagrange Multiplier-Based Optimal Control Technique for Streak Attenuation in High-Speed Boundary Layers,” *AIAA J.*, 2022, pp. 1–14. <https://doi.org/10.2514/1.j062255>.
- [74] Andersson, P., Berggren, M., and Henningson, D. S., “Optimal disturbances and bypass transition in boundary layers,” *Phys. Fluids*, Vol. 11, No. 1, 1999, pp. 134–150. <https://doi.org/10.1063/1.869908>.
- [75] Luchini, P., “Reynolds-number-independent instability of the boundary layer over a flat surface: optimal perturbations,” *J. Fluid Mech.*, Vol. 404, 2000, pp. 289–309. <https://doi.org/10.1017/s0022112099007259>.
- [76] Lucas, J.-M., Vermeersch, O., and Arnal, D., “Transient growth of Görtler vortices in two-dimensional compressible boundary layers. Application to surface waviness,” *Europ. J. Mech.-B/Fluids*, Vol. 50, 2015, pp. 132–146. <https://doi.org/10.1016/j.euromechflu.2014.11.005>.
- [77] Herbert, T., “Parabolized stability equations,” *Annu. Rev. Fluid Mech.*, Vol. 29, No. 1, 1997, pp. 245–283. <https://doi.org/10.1146/annurev.fluid.29.1.245>.
- [78] Chang, C.-L., Malik, M., Erlebacher, G., and Hussaini, M., “Compressible stability of growing boundary layers using parabolized stability equations,” *AIAA Paper*, 1991, pp. 1991–1636. <https://doi.org/10.2514/6.1991-1636>.
- [79] Bertolotti, F. P., and Herbert, T., “Analysis of the linear stability of compressible boundary layers using the PSE,” *Theor. Comp. Fluid Dyn.*, Vol. 3, No. 2, 1991, pp. 117–124. <https://doi.org/10.1007/bf00271620>.
- [80] Ricco, P., and Wu, X., “Response of a compressible laminar boundary layer to free-stream vortical disturbances,” *J. Fluid Mech.*, Vol. 587, 2007, pp. 97–138. <https://doi.org/10.1017/s0022112007007070>.
- [81] Viaro, S., and Ricco, P., “Neutral stability curves of low-frequency Görtler flow generated by free-stream vortical disturbances,” *J. Fluid Mech.*, Vol. 845, No. R1, 2018. <https://doi.org/10.1017/jfm.2018.270>.
- [82] Li, F., and Malik, M. R., “Spectral analysis of parabolized stability equations,” *Comput. Fluids*, Vol. 26, No. 3, 1997, pp. 279–297. [https://doi.org/https://doi.org/10.1016/S0045-7930\(96\)00044-8](https://doi.org/https://doi.org/10.1016/S0045-7930(96)00044-8).
- [83] Li, F., Choudhari, M., Chang, C.-L., Greene, P., and Wu, M., “Development and breakdown of Görtler vortices in high speed boundary layers,” *AIAA Paper*, 2010, pp. 2010–705. <https://doi.org/10.2514/6.2010-705>.
- [84] Huang, G., Si, W., and Lee, C., “Inner structures of Görtler streaks,” *Phys. Fluids*, Vol. 33, No. 3, 2021, p. 034116. <https://doi.org/10.1063/5.0042769>.
- [85] Ren, J., Liu, J., and Fu, S., “The role of Görtler vortices in the hypersonic boundary layer transition,” *AIAA Paper*, Vol. 2014-2642, 2014. <https://doi.org/10.2514/6.2014-2642>.
- [86] Liu, J., Zhang, S., and Fu, S., “Linear spatial instability analysis in 3D boundary layers using plane-marching 3D-LPSE,” *Appl. Math. Mech.*, Vol. 37, No. 8, 2016, pp. 1013–1030. <https://doi.org/10.1007/s10483-016-2114-8>.

- [87] Song, R., Zhao, L., and Huang, Z., “Secondary instability of stationary Görtler vortices originating from first/second Mack mode,” *Phys. Fluids*, Vol. 32, No. 3, 2020, p. 034109. <https://doi.org/10.1063/1.5140222>.
- [88] Chen, X., Zhu, Y., and Lee, C., “Interactions between second mode and low-frequency waves in a hypersonic boundary layer,” *J. Fluid Mech.*, Vol. 820, 2017, p. 693. <https://doi.org/10.1017/jfm.2017.233>.
- [89] Li, F., and Malik, M. R., “Fundamental and subharmonic secondary instabilities of Görtler vortices,” *J. Fluid Mech.*, Vol. 297, 1995, pp. 77–100. <https://doi.org/10.1017/s0022112095003016>.
- [90] Kovasznay, L. S. G., “Turbulence in supersonic flow,” *J. Aero. Sci.*, Vol. 20, 1953, pp. 657–682.
- [91] Bushnell, D., “Notes on initial disturbance fields for the transition problem,” *Instability and transition*, Springer, 1990, pp. 217–232. [https://doi.org/10.1007/978-1-4612-3430-2\\_28](https://doi.org/10.1007/978-1-4612-3430-2_28).
- [92] Morkovin, M. V., “On transition experiments at moderate supersonic speeds,” *J. Aero. Sci.*, Vol. 24, No. 7, 1957, pp. 480–486. <https://doi.org/10.2514/8.3887>.
- [93] Morkovin, M. V., “On supersonic wind tunnels with low free-stream disturbances,” *Trans. ASME J. Appl. Mech.*, Vol. 26, No. 3, 1959, pp. 319–324. <https://doi.org/10.1115/1.4012040>.
- [94] Duan, L., Choudhari, M. M., Chou, A., Munoz, F., Radespiel, R., Schilden, T., Schröder, W., Marineau, E. C., Casper, K. M., Chaudhry, R. S., et al., “Characterization of freestream disturbances in conventional hypersonic wind tunnels,” *J. Spacecr. Rockets*, Vol. 56, No. 2, 2019, pp. 357–368. <https://doi.org/10.2514/1.a34290>.
- [95] Duan, L., Choudhari, M. M., and Wu, M., “Numerical study of acoustic radiation due to a supersonic turbulent boundary layer,” *J. Fluid Mech.*, Vol. 746, 2014, p. 165. <https://doi.org/10.1017/jfm.2014.116>.
- [96] Jacobs, R. G., and Durbin, P. A., “Simulations of bypass transition,” *J. Fluid Mech.*, Vol. 428, 2001, pp. 185–212. <https://doi.org/10.1017/s002211200002469>.
- [97] Schrader, L.-U., Brandt, L., and Zaki, T. A., “Receptivity, instability and breakdown of Görtler flow,” *J. Fluid Mech.*, Vol. 682, 2011, pp. 362–396. <https://doi.org/10.1017/jfm.2011.229>.
- [98] Dong, M., and Wu, X., “On continuous spectra of the Orr–Sommerfeld/Squire equations and entrainment of free-stream vortical disturbances,” *J. Fluid Mech.*, Vol. 732, 2013, pp. 616–659. <https://doi.org/10.1017/jfm.2013.421>.
- [99] Wu, X., and Dong, M., “Entrainment of short-wavelength free-stream vortical disturbances in compressible and incompressible boundary layers,” *J. Fluid Mech.*, Vol. 797, 2016, p. 683–728. <https://doi.org/10.1017/jfm.2016.318>.
- [100] Viaro, S., and Ricco, P., “Neutral stability curves of compressible Görtler flow generated by low-frequency free-stream vortical disturbances,” *J. Fluid Mech.*, Vol. 876, 2019, pp. 1146–1157. <https://doi.org/10.1017/jfm.2019.590>.
- [101] Ricco, P., Luo, J., and Wu, X., “Evolution and instability of unsteady nonlinear streaks generated by free-stream vortical disturbances,” *J. Fluid Mech.*, Vol. 677, 2011, pp. 1–38. <https://doi.org/10.1017/jfm.2011.41>.
- [102] Zhang, Y., Zaki, T., Sherwin, S., and Wu, X., “Nonlinear response of a laminar boundary layer to isotropic and spanwise localized free-stream turbulence,” *AIAA Paper*, 2011, pp. 2011–3292. <https://doi.org/10.2514/6.2011-3292>.
- [103] Marensi, E., and Ricco, P., “Growth and wall-transpiration control of nonlinear unsteady Görtler vortices forced by free-stream vortical disturbances,” *Phys. Fluids*, Vol. 29, No. 11, 2017, p. 114106. <https://doi.org/10.1063/1.4999993>.
- [104] Sescu, A., Afsar, M., and Hattori, Y., “Streaks in high-speed boundary layers: a view through the full nonlinear boundary-region equations,” *AIAA Paper*, 2020, pp. 2020–0830. <https://doi.org/10.2514/6.2020-0830>.
- [105] Ricco, P., Walsh, E. J., Brighenti, F., and McEligot, D. M., “Growth of boundary-layer streaks due to free-stream turbulence,” *Int. J. Heat Fluid Flow*, Vol. 61, 2016, pp. 272–283. <https://doi.org/10.1016/j.ijheatfluidflow.2016.05.003>.
- [106] Xu, D., Liu, J., and Wu, X., “Görtler vortices and streaks in boundary layer subject to pressure gradient: excitation by free stream vortical disturbances, nonlinear evolution and secondary instability,” *J. Fluid Mech.*, Vol. 900, 2020. <https://doi.org/10.1017/jfm.2020.438>.
- [107] Xu, D., and Wu, X., “Elevated low-frequency free-stream vortical disturbances eliminate boundary-layer separation,” *J. Fluid Mech.*, Vol. 920, 2021, p. A14. <https://doi.org/10.1017/jfm.2021.441>.

- [108] Es-Sahli, O., Sescu, A., Afsar, M. Z., Hattori, Y., and Hirota, M., “Effect of localized wall cooling or heating on streaks in high-speed boundary layers,” *AIAA Paper*, 2021, pp. 2021–0853. <https://doi.org/10.2514/6.2021-0853>.
- [109] Hall, P., and Horseman, N. J., “The linear inviscid secondary instability of longitudinal vortex structures in boundary layers,” *J. Fluid Mech.*, Vol. 232, 1991, pp. 357–375. <https://doi.org/10.1017/s0022112091003725>.
- [110] Yu, X., and Liu, J. T. C., “The secondary instability in Görtler flow,” *Phys. Fluids A*, Vol. 3, No. 8, 1991, pp. 1845–1847. <https://doi.org/10.1063/1.857913>.
- [111] Yu, X., and Liu, J. T. C., “On the mechanism of sinuous and varicose modes in three-dimensional viscous secondary instability of nonlinear Görtler rolls,” *Phys. Fluids A*, Vol. 6, No. 2, 1994, pp. 736–750. <https://doi.org/10.1063/1.868312>.
- [112] Chen, X., Huang, G. L., and Lee, C. B., “Hypersonic boundary layer transition on a concave wall: stationary Görtler vortices,” *J. Fluid Mech.*, Vol. 865, 2019, pp. 1–40. <https://doi.org/10.1017/jfm.2019.24>.
- [113] Swearingen, J. D., and Blackwelder, R. F., “The growth and breakdown of streamwise vortices in the presence of a wall,” *J. Fluid Mech.*, Vol. 182, 1987, pp. 255–290. <https://doi.org/10.1017/s0022112087002337>.
- [114] Ren, J., and Fu, S., “Floquet analysis of fundamental, subharmonic and detuned secondary instabilities of Görtler vortices,” *Sci. China Phys. Mech. Astron.*, Vol. 57, No. 3, 2014, pp. 555–561. <https://doi.org/10.1007/s11433-014-5396-2>.
- [115] Zhu, K., and Wu, X., “Effects of spanwise-periodic surface heating on supersonic boundary-layer instability,” *J. Fluid Mech.*, Vol. 940, 2022, p. A20. <https://doi.org/10.1017/jfm.2022.228>.
- [116] Chen, X., Chen, J., Yuan, X., Tu, G., and Zhang, Y., “From primary instabilities to secondary instabilities in Görtler vortex flows,” *Adv. Aerodynamics*, Vol. 1, No. 1, 2019, p. 19. <https://doi.org/10.1186/s42774-019-0021-8>.
- [117] Li, F., Choudhari, M. M., and Paredes, P., “Nonlinear Görtler Vortices and Their Secondary Instability in a Hypersonic Boundary Layer,” *AIAA Paper*, 2019, pp. 2019–3216. <https://doi.org/10.2514/6.2019-3216>.
- [118] Saric, W. S., Carrillo Jr, R. B., and Reibert, M. S., “Leading-edge roughness as a transition control mechanism,” *AIAA Paper*, 1998, pp. 98–0781. <https://doi.org/10.2514/6.1998-781>.
- [119] Kuehl, J., and Paredes, P., “Görtler Modified Mack-Modes on a Hypersonic Flared Cone,” *AIAA Paper*, 2016, pp. 2016–0849. <https://doi.org/10.2514/6.2016-0849>.
- [120] Ren, J., Fu, S., and Hanifi, A., “Stabilization of the hypersonic boundary layer by finite-amplitude streaks,” *Phys. Fluids*, Vol. 28, No. 2, 2016, p. 024110. <https://doi.org/10.1063/1.4941989>.
- [121] Cossu, C., and Brandt, L., “Stabilization of Tollmien-Schlichting waves by finite amplitude optimal streaks in the Blasius boundary layer,” *Phys. Fluids*, Vol. 14, No. 8, 2002, pp. L57–L60. <https://doi.org/10.1063/1.1493791>.
- [122] Ricco, P., and Fossà, L., “Receptivity of compressible boundary layers over porous surfaces,” *Phys. Rev. Fluids*, Vol. 8, No. 073903, 2023. <https://doi.org/10.1103/PhysRevFluids.8.073903>.
- [123] Winoto, S. H., Shah, D. A., and Mitsudharmadi, H., “Concave surface boundary layer flows in the presence of streamwise vortices,” *Int. J. Fluid Mach. Syst.*, Vol. 4, No. 1, 2011, pp. 33–46. <https://doi.org/10.5293/ijfms.2011.4.1.033>.
- [124] Boiko, A. V., Ivanov, A. V., Kachanov, Y. S., and Mischenko, D. A., “Steady and unsteady Görtler boundary-layer instability on concave wall,” *Europ. J. Mech. B/Fluids*, Vol. 29, No. 2, 2010, pp. 61–83. <https://doi.org/10.1016/j.euromechflu.2009.11.001>.
- [125] Cui, J., Rao, N. V., and Tucker, P., “Numerical investigation of contrasting flow physics in different zones of a high-lift low-pressure turbine blade,” *ASME J. Turbomach.*, Vol. 138, No. 1, 2016. <https://doi.org/10.1115/gt2015-43200>.
- [126] Simeonides, G., and Haase, W., “Experimental and computational investigations of hypersonic flow about compression ramps,” *J. Fluid Mech.*, Vol. 283, 1995, pp. 17–42. <https://doi.org/10.1017/s0022112095002229>.
- [127] Balakumar, P., Zhao, H., and Atkins, H., “Stability of hypersonic boundary layers over a compression corner,” *AIAA J.*, Vol. 43, No. 4, 2005, pp. 760–767. <https://doi.org/10.2514/6.2002-2848>.
- [128] Ginoux, J. J., “Experimental evidence of three-dimensional perturbations in the reattachment of a two-dimensional laminar boundary layer at  $M=2.05$ ,” *VKI Training Center for Experimental Aerodynamics Technical*, 1958.

- [129] Ginoux, J. J., "Effect of Mach number on streamwise vortices in laminar reattaching flows," *VKI Training Center for Experimental Aerodynamics Tech. Note 26*, 1965.
- [130] Ginoux, J. J., "On some properties of reattaching laminar and transitional high speed flows," *VKI Training Center for Experimental Aerodynamics Tech. Note 53*, 1969.
- [131] Ginoux, J. J., "Streamwise vortices in reattaching high-speed flows: a suggested approach," *AIAA J.*, Vol. 9, No. 4, 1971, pp. 759–760. <https://doi.org/10.2514/3.6271>.
- [132] Inger, G. R., "On the curvature of compressible boundary layer flows near separation," *J. Applied Math. Phys. (ZAMP)*, Vol. 28, No. 6, 1977, pp. 1027–1035. <https://doi.org/10.1007/bf01601670>.
- [133] Inger, G., "Three-dimensional heat-and mass-transfer effects across high-speed reattaching flows," *AIAA J.*, Vol. 15, No. 3, 1977, pp. 383–389.
- [134] Namtu, N., and Inger, G. R., "Spanwise-Periodic Three-Dimensional Disturbances in Nominally 2-D Separating Laminar Boundary Layer Flows," *VPI & SU Report Aero-052, Blacksburg, Virginia*, 1976.
- [135] De Luca, L., Cardone, G., and Carlomagno, G., "Experimental investigation on Goertler vortices in hypersonic flow," *WIT Transactions on Modelling and Simulation*, Vol. 4, 1993.
- [136] Chapman, D., Kuehn, D., and Larson, H., "Investigation of separated flows in supersonic and subsonic streams with emphasis on the effect of transition," *NACA TN-3869*, 1957.
- [137] De Luca, L., Cardone, G., Aymer de la Chevalerie, D. A., and Fonteneau, A., "Görtler instability of a hypersonic boundary layer," *Exp. Fluids*, Vol. 16, 1993, pp. 10–16. <https://doi.org/10.1007/BF00188500>.
- [138] De Luca, L., Cardone, G., and de la Chevalerie, D. A., "Experiments versus theory on streaky structures in compressible flow," *WIT Transactions on Modelling and Simulation*, Vol. 16, 1997.
- [139] Holden, M., and Chadwick, K., "Studies of laminar, transitional, and turbulent hypersonic flows over curved compression surfaces," *AIAA Paper*, 1995, pp. 1995–93. <https://doi.org/10.2514/6.1995-93>.
- [140] Ciolkosz, L., and Spina, E., "An experimental study of Görtler vortices in compressible flow," *AIAA Paper*, 2006, pp. 2006–4512. <https://doi.org/10.2514/6.2006-4512>.
- [141] Tumin, A. M., and Chernov, I. P., "Asymptotic analysis of flow stability in a compressible boundary layer on a curved surface," *PMTF Zhurnal Prikladnoi Mekhaniki i Tekhnicheskoi Fiziki*, 1988, pp. 84–89. <https://doi.org/10.1007/bf00853486>.
- [142] Ciolkosz, L., *On the existence and character of Görtler vortices in compressible flow*, Ph.D. Thesis - Syracuse University, 2003.
- [143] Flaherty, W., and Austin, J. M., "Scaling of heat transfer augmentation due to mechanical distortions in hypervelocity boundary layers," *Phys. Fluids*, Vol. 25, No. 10, 2013, p. 106106. <https://doi.org/10.1063/1.4826476>.
- [144] Austin, J., and Flaherty, W. P., "Hypervelocity Boundary Layer Studies for Axisymmetric Engine Flowpaths," Tech. Rep. 0704-0188, University of Illinois, 2011.
- [145] Wang, Q.-C., Wang, Z.-G., and Zhao, Y.-X., "Visualization of Görtler vortices in supersonic concave boundary layer," *J. Visual.*, Vol. 21, No. 1, 2018, pp. 57–62. <https://doi.org/10.1007/s12650-017-0443-5>.
- [146] Huang, G., Si, W., and Lee, C., "Early stage evolution of naturally developing Görtler streaks," *Phys. Fluids*, Vol. 33, No. 6, 2021, p. 061706. <https://doi.org/10.1063/5.0055849>.
- [147] Beckwith, I. E., Chen, F.-J., and Creel, T. R., "Design requirements for the NASA Langley supersonic low-disturbance wind tunnel," *AIAA Paper*, 1986, pp. 86–0763. <https://doi.org/10.2514/6.1986-763>.
- [148] Anders, J. B., Stainback, P. C., Keefe, L. R., and Beckwith, I. E., "Fluctuating disturbances in a Mach 5 wind tunnel," *AIAA J.*, Vol. 15, No. 8, 1977, pp. 1123–1129. <https://doi.org/10.2514/3.60763>.
- [149] Wilkinson, S., Anders, S., Chen, F.-J., and Beckwith, I., "Supersonic and hypersonic quiet tunnel technology at NASA Langley," *AIAA Paper*, 1992, pp. 1992–3908. <https://doi.org/10.2514/6.1992-3908>.
- [150] Wilkinson, S., "A review of hypersonic boundary layer stability experiments in a quiet Mach 6 wind tunnel," *AIAA Paper*, 1997, pp. 1997–1819. <https://doi.org/10.2514/6.1997-1819>.

- [151] Pate, S. R., and Schueler, C. J., "Radiated aerodynamic noise effects on boundary-layer transition in supersonic and hypersonic wind tunnels," *AIAA J.*, Vol. 7, No. 3, 1969, pp. 450–457. <https://doi.org/10.2514/3.5128>.
- [152] Pate, S. R., "Measurements and correlations of transition Reynolds numbers on sharp slender cones at high speeds," *AIAA J.*, Vol. 9, 1971, pp. 1082–1090. <https://doi.org/10.2514/3.49919>.
- [153] Pate, S., "Effects of wind tunnel disturbances on boundary-layer transition with emphasis on radiated noise: a review," *AIAA Paper*, Vol. 80-0431, 1980.
- [154] Schneider, S. P., "Design of a Mach-6 quiet-flow wind-tunnel nozzle using the e\*\*N method for transition estimation," *AIAA Paper*, Vol. 98-0547, 1998. <https://doi.org/10.2514/6.1998-547>.
- [155] Harvey, W. D., Stainback, P. C., Anders, J. B., and Cary, A. M., "Nozzle wall boundary-layer transition and freestream disturbances at Mach 5," *AIAA J.*, Vol. 13, No. 3, 1975, pp. 307–314. <https://doi.org/10.2514/3.49696>.
- [156] Beckwith, I. E., "Development of a high Reynolds number quiet tunnel for transition research," *AIAA J.*, Vol. 13, No. 3, 1975, pp. 300–306. <https://doi.org/10.2514/3.49695>.
- [157] Beckwith, I. E., and Holley, B. B., "Görtler vortices and transition in wall boundary layers of two Mach 5 nozzles," *NASA STI/Recon Technical Report*, Vol. 81, 1981, p. 31509.
- [158] Beckwith, I. E., Malik, M. R., and Chen, F.-J., "Nozzle optimization study for quiet supersonic wind tunnels," *AIAA Paper*, 1984, pp. 1984–1628. <https://doi.org/10.2514/6.1984-1628>.
- [159] Chen, F.-J., Malik, M. R., and Beckwith, I. E., "Instabilities and transition in the wall boundary layers of low-disturbance supersonic nozzles," *AIAA Paper*, Vol. 1985-1573, 1985. <https://doi.org/10.2514/6.1985-1573>.
- [160] Chen, F.-J., Malik, M. R., and Beckwith, I. E., "Görtler instability and supersonic quiet nozzle design," *AIAA J.*, Vol. 30, No. 8, 1992, pp. 2093–2094. <https://doi.org/10.2514/3.11184>.
- [161] Chen, F.-J., and Wilkinson, S. P., "Design of Mach 2.4 Quiet Nozzles for the NASA Langley Supersonic Low-Disturbance Pilot Tunnel," *AIAA Paper*, Vol. 94-2506, 1994. <https://doi.org/10.2514/6.1994-2506>.
- [162] Chen, F.-J., Wilkinson, S. P., and Beckwith, I. E., "Görtler instability and hypersonic quiet nozzle design," *J. Spacecr. Rocket.*, Vol. 30, No. 2, 1993, pp. 170–175. <https://doi.org/10.2514/6.1991-1648>.
- [163] Blanchard, A. E., Lachowicz, J. T., and Wilkinson, S. P., "Performance of the NASA-Langley Mach 6 quiet wind tunnel," *AIAA Paper*, 1996, pp. 96–0441. <https://doi.org/10.2514/6.1996-441>.
- [164] Doggett, G., and Chokani, N., "Hypersonic Boundary-Layer Stability Experiments on a Flared-Cone Model at Angle of Attack in a Quiet Wind Tunnel," *NASA Contractor Report*, Vol. 201617, 1996, p. 7.
- [165] Doggett, G. P., Chokani, N., and Wilkinson, S. P., "Hypersonic boundary-layer stability experiments on a flared-cone model at angle of attack in a quiet wind tunnel," *AIAA Paper*, 1997, pp. 97–0557. <https://doi.org/10.2514/6.1997-557>.
- [166] Flood, J. T., Craig, S. A., and Taubert, L., "Flow quality mapping of the Mach 4 Quiet Ludwig Tube," *AIAA Paper*, 2020, pp. 2020–0360. <https://doi.org/10.2514/6.2020-0360>.
- [167] Juliano, T. J., Schneider, S. P., Aradag, S., and Knight, D., "Quiet-flow Ludwig tube for hypersonic transition research," *AIAA J.*, Vol. 46, No. 7, 2008, pp. 1757–1763. <https://doi.org/10.2514/1.34640>.
- [168] Zhang, C.-H., Tang, Q., and Lee, C.-B., "Hypersonic boundary-layer transition on a flared cone," *Acta Mech. Sin.*, Vol. 29, No. 1, 2013, pp. 48–54. <https://doi.org/10.1007/s10409-013-0009-2>.
- [169] Hofferth, J., Humble, R., Floryan, D., and Saric, W., "High-bandwidth optical measurements of the second-mode instability in a Mach 6 quiet tunnel," *AIAA Paper*, 2013, pp. 2013–0378. <https://doi.org/10.2514/6.2013-378>.
- [170] Hofferth, J., Saric, W., Kuehl, J., Perez, E., Kocian, T., and Reed, H., "Boundary-layer instability and transition on a flared cone in a Mach 6 quiet wind tunnel," *Int. J. Eng. Syst. Model. Simul.*, Vol. 5, No. 1-3, 2013, pp. 109–124. <https://doi.org/10.1504/ijesms.2013.052386>.
- [171] Hofferth, J., and Saric, W., "Boundary-layer transition on a flared cone in the Texas A&M Mach 6 quiet tunnel," *AIAA Paper*, 2012, pp. 2012–923. <https://doi.org/10.2514/6.2012-923>.

- [172] Ward, C., Wheaton, B., Chou, A., Gilbert, P., Steen, L., and Schneider, S., “Boundary-layer transition measurements in a Mach-6 quiet tunnel,” *AIAA Paper*, 2010, pp. 2010–4721. <https://doi.org/10.2514/6.2010-4721>.
- [173] Liu, X., Yi, S., Xu, X., Shi, Y., Ouyang, T., and Xiong, H., “Experimental study of second-mode wave on a flared cone at Mach 6,” *Phys. Fluids*, Vol. 31, No. 7, 2019, p. 074108. <https://doi.org/10.1063/1.5103192>.
- [174] Lachowicz, J. T., Chokani, N., and Wilkinson, S. P., “Boundary-layer stability measurements in a hypersonic quiet tunnel,” *AIAA J.*, Vol. 34, No. 12, 1996, pp. 2496–2500. <https://doi.org/10.2514/3.13430>.
- [175] Blanchard, A. E., and Selby, G. V., “An experimental investigation of wall-cooling effects on hypersonic boundary-layer stability in a quiet wind tunnel,” *NASA Tech. Rep.*, Vol. 198287, 1996.
- [176] Horvath, T., Berry, S., Hollis, B., Singer, B., and Chang, C.-L., “Boundary layer transition on slender cones in conventional and low disturbance Mach 6 wind tunnels,” *AIAA Paper*, 2002, pp. 2002–2743. <https://doi.org/10.2514/6.2002-2743>.
- [177] Schneider, S. P., “Hypersonic laminar–turbulent transition on circular cones and scramjet forebodies,” *Prog. Aero. Sci.*, Vol. 40, No. 1-2, 2004, pp. 1–50. <https://doi.org/10.1016/j.paerosci.2003.11.001>.
- [178] Hofferth, J., Bowersox, R., and Saric, W., “The Mach 6 quiet tunnel at Texas A&M: quiet flow performance,” *AIAA Paper*, 2010, pp. 2010–4794. <https://doi.org/10.2514/6.2010-4794>.
- [179] Johnson, H., Alba, C., Bartkowicz, M., Drayna, T., and Candler, G., “Design Optimization of Hypersonic Vehicles for Boundary Layer Stability,” *AIAA Paper*, 2008, pp. 2008–6221. <https://doi.org/10.2514/6.2008-6221>.
- [180] Berridge, D., Chou, A., Ward, C., Steen, L., Gilbert, P., Juliano, T., Schneider, S., and Gronvall, J., “Hypersonic boundary-layer transition experiments in a Mach-6 quiet tunnel,” *AIAA Paper*, 2010, pp. 2010–1061. <https://doi.org/10.2514/6.2010-1061>.
- [181] Berridge, D., Ward, C., Wheaton, B., Luersen, R., Chou, A., Abney, A., and Schneider, S., “Boundary-layer instability measurements in a Mach-6 quiet tunnel,” *AIAA Paper*, 2012, pp. 2012–3147. <https://doi.org/10.2514/6.2012-3147>.
- [182] Chou, A., Ward, C., Letterman, L., Schneider, S., Luersen, R., and Borg, M., “Transition research with temperature-sensitive paints in the Boeing/AFOSR Mach-6 quiet tunnel,” *AIAA Paper*, 2011, pp. 2011–3872. <https://doi.org/10.2514/6.2011-3872>.
- [183] Chou, A., “Characterization of laser-generated perturbations and instability measurements on a flared cone,” Ph.D. thesis, M.S. thesis, Purdue University, School of Aeronautics and Astronautics, 2010.
- [184] Craig, S. A., Humble, R. A., Hofferth, J. W., and Saric, W. S., “Nonlinear behaviour of the Mack mode in a hypersonic boundary layer,” *J. Fluid Mech.*, Vol. 872, 2019, pp. 74–99. <https://doi.org/10.1017/jfm.2019.359>.
- [185] Zhu, Y., Zhu, W., Gu, D., Lee, C., and Smith, C. R., “Characteristics of transition to turbulence over a Mach 6 flared cone,” *Phys. Fluids*, Vol. 33, No. 10, 2021, p. 101708. <https://doi.org/10.1063/5.0068153>.
- [186] Zhu, Y., Zhu, W., Gu, D., Chen, S., Lee, C., and Oran, E. S., “Acoustic-wave-induced cooling in onset of hypersonic turbulence,” *Phys. Fluids*, Vol. 32, No. 6, 2020, p. 061702. <https://doi.org/10.1063/5.0011871>.
- [187] Zhu, Y., Zhu, W., Gu, D., Lee, C., and Smith, C. R., “Hypersonic transition over a heated wall,” *Phys. Fluids*, Vol. 33, No. 10, 2021, p. 101706. <https://doi.org/10.1063/5.0068157>.
- [188] Yu, J., Zhu, Y., Gu, D., and Lee, C., “A thermoacoustic heat pump driven by acoustic waves in a hypersonic boundary layer,” *Phys. Fluids*, Vol. 34, No. 1, 2022, p. 011703. <https://doi.org/10.1063/5.0079611>.
- [189] Zhu, Y., Zhu, W., Gu, D., Lee, C., and Smith, C. R., “Transitional flow structures in heated hypersonic boundary layers,” *Phys. Fluids*, Vol. 34, No. 5, 2022, p. 054114. <https://doi.org/10.1063/5.0091192>.
- [190] Lee, C., and Chen, S., “Recent progress in the study of transition in the hypersonic boundary layer,” *Nati. Sci. Rev.*, Vol. 6, No. 1, 2019, pp. 155–170. <https://doi.org/10.1093/nsr/nwy052>.
- [191] Gang, D., Yi, S., and Lu, X., “Design and performance of a hypersonic quiet wind tunnel at NUDT,” *AIAA Paper*, 2017, pp. 2017–2305. <https://doi.org/10.2514/6.2017-2305>.
- [192] Lachowicz, J., Chokani, N., and Wilkinson, S., “Hypersonic boundary layer stability over a flared cone in a quiet tunnel,” *AIAA Paper*, 1996, pp. 96–782. <https://doi.org/10.2514/6.1996-782>.

- [193] Miller, D. S., Hijman, R., and Childs, M. E., “Mach 8 to 22 studies of flow separations due to deflected control surfaces,” *AIAA J.*, Vol. 2, No. 2, 1964, pp. 312–321. <https://doi.org/10.2514/3.2289>.
- [194] De Luca, L., Cardone, G., Chevalerie, D. A., and Fonteneau, A., “Viscous interaction phenomena in hypersonic wedge flow,” *AIAA J.*, Vol. 33, No. 12, 1995, pp. 2293–2298. <https://doi.org/10.2514/3.12982>.
- [195] Simeonides, G., Haase, W., and Manna, M., “Experimental, analytical, and computational methods applied to hypersonic compression ramp flows,” *AIAA J.*, Vol. 32, No. 2, 1994, pp. 301–310. <https://doi.org/10.2514/3.11985>.
- [196] de la Chevalerie, D. A., Fonteneau, A., De Luca, L., and Cardone, G., “Görtler-type vortices in hypersonic flows: the ramp problem,” *Exp. Therm. Fluid Sc.*, Vol. 15, No. 2, 1997, pp. 69–81. [https://doi.org/10.1016/s0894-1777\(97\)00051-4](https://doi.org/10.1016/s0894-1777(97)00051-4).
- [197] Ishiguro, Y., Nagai, H., Asai, K., and Nakakita, K., “Visualization of hypersonic compression corner flows using temperature- and pressure-sensitive paints,” *AIAA Paper*, 2007, pp. 2007–118. <https://doi.org/10.2514/6.2007-118>.
- [198] Marini, M., “Analysis of hypersonic compression ramp laminar flows under sharp leading edge conditions,” *Aero. Sc. Tech.*, Vol. 5, No. 4, 2001, pp. 257–271. [https://doi.org/10.1016/s1270-9638\(01\)01109-9](https://doi.org/10.1016/s1270-9638(01)01109-9).
- [199] Benay, R., Chanetz, B., Mangin, B., Vandomme, L., and Perraud, J., “Shock wave/transitional boundary-layer interactions in hypersonic flow,” *AIAA J.*, Vol. 44, No. 6, 2006, pp. 1243–1254. <https://doi.org/10.2514/1.10512>.
- [200] Zhuang, Y., Tan, H.-J., Liu, Y.-Z., Zhang, Y.-C., and Ling, Y., “High resolution visualization of Görtler-like vortices in supersonic compression ramp flow,” *J. Visual.*, Vol. 20, No. 3, 2017, pp. 505–508. <https://doi.org/10.1007/s12650-016-0415-1>.
- [201] Schrijer, F., “Investigation of Görtler vortices in a hypersonic double compression ramp flow by means of infrared thermography,” *Quant. Infrared Therm. J.*, Vol. 7, No. 2, 2010, pp. 201–215. <https://doi.org/10.3166/qirt.7.201-215>.
- [202] Roghelia, A., Olivier, H., Egorov, I., and Chuvakhov, P., “Experimental investigation of Görtler vortices in hypersonic ramp flows,” *Exp. Fluids*, Vol. 58, No. 10, 2017, p. 139. <https://doi.org/10.1007/s00348-017-2422-y>.
- [203] Zapryagaev, V. I., and Kavun, I. N., “Formation of streamwise vortices behind the line of supersonic separated flow reattachment at a compression corner,” *TsAGI Science J.*, Vol. 47, No. 3, 2016. <https://doi.org/10.1615/tsagiscij.2016018291>.
- [204] Trubitsyna, L. P., Zapryagaev, V. I., and Kavun, I. N., “Effect of side walls on the supersonic ramp flow structure,” *J. Phys.: Conf. Series*, Vol. 1404, IOP Publishing, 2019, p. 012101. <https://doi.org/10.1088/1742-6596/1404/1/012101>.
- [205] Li, X., Zhang, Y., Yu, H., Lin, Z., Tan, H., and Sun, S., “Görtler vortices behavior and prediction in dual-incident shock-wave/turbulent-boundary-layer interactions,” *Phys. Fluids*, Vol. 34, No. 10, 2022, p. 106103. <https://doi.org/10.1063/5.0100718>.
- [206] Chuvakhov, P., Radchenko, V., Alexandrova, E., and Borovoy, V., “Effect of controlled periodic roughness on Goertler vortices in hypersonic compression ramp flow,” *31st Congr. Int. Council Aero. Sc, ICAS 2018*, 2018.
- [207] Chuvakhov, P. V., Borovoy, V. Y., Egorov, I. V., Radchenko, V. N., Olivier, H., and Roghelia, A., “Effect of small bluntness on formation of Görtler vortices in a supersonic compression corner flow,” *J. Appl. Mech. Tech. Phys.*, Vol. 58, No. 6, 2017, pp. 975–989. <https://doi.org/10.1134/s0021894417060037>.
- [208] Chuvakhov, P. V., and Radchenko, V. N., “Effect of Görtler-like vortices of various intensity on heat transfer in supersonic compression corner flows,” *Int. J. Heat Fluid Flow*, Vol. 150, 2020, p. 119310. <https://doi.org/10.1016/j.ijheatmasstransfer.2020.119310>.
- [209] Currao, G., Neely, A., Kennell, C., Gai, S., and Buttsworth, D., “Hypersonic fluid–structure interaction on a cantilevered plate with shock impingement,” *AIAA J.*, Vol. 57, No. 11, 2019, pp. 4819–4834. <https://doi.org/10.2514/1.J058375>.
- [210] Currao, G., Choudhury, R., Gai, S., Neely, A., and Buttsworth, D., “Hypersonic transitional shock-wave–boundary-layer interaction on a flat plate,” *AIAA J.*, Vol. 58, No. 2, 2020, pp. 814–829. <https://doi.org/10.2514/1.J058718>.
- [211] Currao, G., McQuellin, L., Neely, A., Gai, S., O’Byrne, S., Zander, F., Buttsworth, D., McNamara, J., and Jahn, I., “Hypersonic oscillating shock-wave/boundary-layer interaction on a flat plate,” *AIAA J.*, Vol. 59, No. 3, 2021, pp. 940–959. <https://doi.org/10.2514/1.J059590>.
- [212] Han, L. S., and Cox, W. R., “A visual study of turbine blade pressure-side boundary layers,” *Turbo Expo: Power for Land, Sea, and Air*, Vol. 79566, American Society of Mechanical Engineers, 1982, p. V001T01A020. <https://doi.org/10.1115/82-gt-47>.
- [213] Brown, A., and Martin, B. W., “Flow transition phenomena and heat transfer over the pressure surfaces of gas turbine blades,” *J. Eng. Power Trans. ASME*, Vol. 104, No. 2, 1982, pp. 360–367. <https://doi.org/10.1115/81-gt-107>.

- [214] Riley, S., Johnson, M. W., and Gibbings, J. C., “Boundary layer transition of strongly concave surfaces,” *Int. Gas Turbine and Aeroengine Congr. Exposition*, ASME, 1989. <https://doi.org/10.1115/89-gt-321>.
- [215] Turner, A. B., “Local heat transfer measurements on a gas turbine blade,” *J. Mech. Eng. Sc.*, Vol. 13, No. 1, 1971, pp. 1–12. [https://doi.org/10.1243/jmes\\_jour\\_1971\\_013\\_003\\_02](https://doi.org/10.1243/jmes_jour_1971_013_003_02).
- [216] Baughn, J., Butler, R., Byerley, A., and Rivir, R., “An Experimental Investigation of Heat Transfer, Transition and Separation on Turbine Blades at Low Reynolds Number and High Turbulence Intensity,” Tech. rep., Wright Lab, Wright-Patterson, AFB, OH, 1995.
- [217] Butler, R. J., Byerley, A. R., VanTreuren, K., and Baughn, J. W., “The effect of turbulence intensity and length scale on low-pressure turbine blade aerodynamics,” *Int. J. Heat Fluid Flow*, Vol. 22, No. 2, 2001, pp. 123–133. [https://doi.org/10.1016/s0142-727x\(00\)00081-3](https://doi.org/10.1016/s0142-727x(00)00081-3).
- [218] Wang, H. P., Olson, S. J., and Goldstein, R. J., “Development of Taylor-Görtler Vortices Over the Pressure Surface of a Turbine Blade,” *ASME J. Heat Transfer*, Vol. 127, No. 5, 2005, pp. 540–543. <https://doi.org/10.1115/1.1865219>.
- [219] Gostelow, J. P., Mahallati, A., Carscallen, W. E., and Rona, A., “Organized Streamwise Vorticity on Convex Surfaces With Particular Reference to Turbine Blades,” *AIAA Paper*, 2010, pp. 2010–0904. <https://doi.org/10.2514/6.2010-904>.
- [220] Gostelow, J. P., Mahallati, A., Carscallen, W. E., and Rona, A., “Encounters with vortices in a turbine nozzle passage,” *Int. J. Rotating Mach.*, Vol. 2012, 2012, p. 928623. <https://doi.org/10.1155/2012/928623>.
- [221] Liu, Q., Baccarella, D., and Lee, T., “Review of combustion stabilization for hypersonic airbreathing propulsion,” *Prog. Aerosp. Sci.*, Vol. 119, 2020, p. 100636. <https://doi.org/10.1016/j.paerosci.2020.100636>.
- [222] Berry, S. A., Auslender, A. H., Dilley, A. D., and Calleja, J. F., “Hypersonic boundary-layer trip development for Hyper-X,” *J. Spacecr. Rocket.*, Vol. 38, No. 6, 2001, pp. 853–864. <https://doi.org/10.2514/6.2000-4012>.
- [223] Whang, C., and Zhong, X., “Direct Numerical Simulation of Görtler Instability in Hypersonic Boundary Layers,” *AIAA Paper*, 1999, pp. 1999–529. <https://doi.org/10.2514/6.1999-291>.
- [224] Whang, C., and Zhong, X., “Nonlinear interaction of Görtler and second shear modes in hypersonic boundary layers,” *AIAA Paper*, 2000, pp. 2000–536. <https://doi.org/10.2514/6.2000-536>.
- [225] Whang, C., and Zhong, X., “Secondary Görtler instability in hypersonic boundary layers,” *AIAA Paper*, 2001, pp. 2001–273. <https://doi.org/10.2514/6.2001-273>.
- [226] Zhong, X., and Whang, C., “Receptivity of Görtler vortices in hypersonic boundary layers,” *AIAA Paper*, 2002, pp. 2002–151. <https://doi.org/10.2514/6.2002-151>.
- [227] Whang, C., and Zhong, X., “Leading edge receptivity of Görtler vortices in a Mach 15 flow over a blunt wedge,” *AIAA Paper*, 2003, pp. 2003–790. <https://doi.org/10.2514/6.2003-790>.
- [228] Whang, C., “Numerical studies on receptivity and transition of Görtler instabilities in hypersonic boundary layers,” Ph.D. thesis, University of California, 2003.
- [229] Yu, M., and Yuan, X.-J., “The effect of Görtler instability on hypersonic boundary layer transition,” *Theor. Appl. Mech. Lett.*, Vol. 6, No. 2, 2016, pp. 97–99. <https://doi.org/10.1016/j.taml.2016.02.003>.
- [230] Chen, X., Chen, J., and Yuan, X., “Hypersonic boundary layer transition on a concave wall induced by low-frequency blowing and suction,” *Phys. Fluids*, Vol. 34, No. 11, 2022, p. 114105. <https://doi.org/10.1063/5.0113570>.
- [231] Sescu, A., Alaziz, R., and Afsar, M., “Control of Görtler Vortices in High-speed Boundary Layers,” *AIAA Paper*, Vol. 2018-1078, 2018. <https://doi.org/10.2514/6.2018-1078>.
- [232] Sescu, A., Alaziz, R., and Afsar, M., “Effect of wall transpiration and heat transfer on Görtler vortices in high-speed flows,” *AIAA J.*, Vol. 57, No. 3, 2019, pp. 1159–1171. <https://doi.org/10.2514/1.j057330>.
- [233] Huang, G., Chen, X., Chen, J., Yuan, X., and Tu, G., “The stabilizing effect of grooves on Görtler instability-induced boundary layer transition in hypersonic flow,” *Phys. Fluids*, Vol. 35, No. 4, 2023. <https://doi.org/https://doi.org/10.1063/5.0146348>.
- [234] Li, F., Choudhari, M., Chang, C.-L., and White, J., “Analysis of instabilities in non-axisymmetric hypersonic boundary layers over cones,” *AIAA Paper*, 2010, pp. 2010–4643. <https://doi.org/10.2514/6.2010-4643>.

- [235] Pruett, C. D., and Chang, C.-L., “Direct numerical simulation of hypersonic boundary-layer flow on a flared cone,” *Theor. Comput. Fluid Dyn.*, Vol. 11, No. 1, 1998, pp. 49–67. <https://doi.org/10.1007/s001620050080>.
- [236] Laible, A., and Fasel, H., “Numerical investigation of hypersonic transition for a flared and a straight cone at Mach 6,” *AIAA Paper*, 2011, pp. 2011–3565. <https://doi.org/10.2514/6.2011-3565>.
- [237] Balakumar, P., and Kegerise, M. A., “Receptivity of hypersonic boundary layers over straight and flared cones,” *AIAA J.*, Vol. 53, No. 8, 2015, pp. 2097–2109. <https://doi.org/10.2514/1.j053432>.
- [238] Hader, C., and Fasel, H. F., “Laminar-turbulent transition on a flared cone at Mach 6,” *AIAA Paper*, 2016, pp. 2016–3344. <https://doi.org/10.2514/6.2016-3344>.
- [239] Li, F., Choudhari, M. M., Paredes, P., Schneider, S. P., and Portoni, P., “Görtler Instability and Its Control via Surface Suction Over an Axisymmetric Cone at Mach 6,” *AIAA Paper*, 2018, pp. 2018–3069. <https://doi.org/10.2514/6.2018-3069>.
- [240] Hader, C., and Fasel, H. F., “Flow control using steady blowing and suction strips in a Mach 6 Boundary Layer on a Flared Cone,” *AIAA Paper*, 2021, pp. 2021–1206. <https://doi.org/10.2514/6.2021-1206>.
- [241] Laible, A. C., *Numerical Investigation of Boundary–Layer Transition for Cones at Mach 3.5 and 6.0*, The University of Arizona, 2011.
- [242] Wu, X., Luo, J., and Yu, M., “Transition route of Klebanoff type in hypersonic boundary layers,” *AIAA Paper*, 2016, pp. 2016–3953. <https://doi.org/10.2514/6.2016-3953>.
- [243] Fasel, H. F., Sivasubramanian, J., and Laible, A., “Numerical investigation of transition in a flared cone boundary layer at Mach 6,” *Procedia IUTAM*, Vol. 14, 2015, pp. 26–35. <https://doi.org/10.1016/j.piutam.2015.03.020>.
- [244] Leib, S. J., and Lee, S. S., “Nonlinear evolution of a pair of oblique instability waves in a supersonic boundary layer,” *J. Fluid Mech.*, Vol. 282, 1995, pp. 339–371. <https://doi.org/10.1017/s0022112095000164>.
- [245] Hader, C., and Fasel, H. F., “Direct numerical simulations of hypersonic boundary-layer transition for a flared cone: fundamental breakdown,” *J. Fluid Mech.*, Vol. 869, 2019, pp. 341–384. <https://doi.org/10.1017/jfm.2019.202>.
- [246] Hader, C., and Fasel, H. F., “Towards simulating natural transition in hypersonic boundary layers via random inflow disturbances,” *J. Fluid Mech.*, Vol. 847, 2018. <https://doi.org/10.1017/jfm.2018.386>.
- [247] Hollender, C., Dwivedi, A., and Candler, G., “Görtler instability analysis of Mach 6 flow on a flared axisymmetric cone with and without suction,” *AIAA Paper*, 2019, pp. 2019–3219. <https://doi.org/10.2514/6.2019-3219>.
- [248] Balakumar, P., and Kegerise, M., “Receptivity of Hypersonic Boundary Layers over Straight and Flared Cones,” 2010, pp. 2010–1065. <https://doi.org/10.2514/6.2010-1065>.
- [249] Hildebrand, N., Dwivedi, A., Nichols, J. W., Jovanović, M. R., and Candler, G. V., “Simulation and stability analysis of oblique shock-wave/boundary-layer interactions at Mach 5.92,” *Phys. Rev. Fluids*, Vol. 3, No. 1, 2018, p. 013906. <https://doi.org/10.1103/physrevfluids.3.013906>.
- [250] Dwivedi, A., Sidharth, G. S., Nichols, J. W., Candler, G. V., and Jovanović, M. R., “Reattachment streaks in hypersonic compression ramp flow: an input–output analysis,” *J. Fluid Mech.*, Vol. 880, 2019, pp. 113–135. <https://doi.org/10.1017/jfm.2019.702>.
- [251] Cao, S., Klioutchnikov, I., and Olivier, H., “Görtler vortices in hypersonic flow on compression ramps,” *AIAA J.*, Vol. 57, No. 9, 2019, pp. 3874–3884. <https://doi.org/10.2514/1.j057975>.
- [252] Hao, J., and Wen, C.-Y., “Hypersonic flow over spherically blunted double cones,” *J. Fluid Mech.*, Vol. 896, 2020, p. A26. <https://doi.org/10.1017/jfm.2020.331>.
- [253] Cao, S., Klioutchnikov, I., and Olivier, H., “Görtler number evaluation for laminar separated hypersonic compression ramp flow,” *AIAA J.*, Vol. 58, No. 8, 2020, pp. 3706–3710. <https://doi.org/10.2514/1.j059588>.
- [254] Cao, S., Hao, J., Klioutchnikov, I., Olivier, H., and Wen, C.-Y., “Unsteady effects in a hypersonic compression ramp flow with laminar separation,” *J. Fluid Mech.*, Vol. 912, 2021, p. A3. <https://doi.org/10.1017/jfm.2020.1093>.
- [255] Hao, J., Cao, S., Wen, C.-Y., and Olivier, H., “Occurrence of global instability in hypersonic compression corner flow,” *J. Fluid Mech.*, Vol. 919, 2021, p. A4. <https://doi.org/10.1017/jfm.2021.372>.

- [256] Cao, S., Hao, J., Klioutchnikov, I., Olivier, H., Heufer, K. A., and Wen, C.-Y., “Leading-edge bluntness effects on hypersonic three-dimensional flows over a compression ramp,” *J. Fluid Mech.*, Vol. 923, 2021, p. A27. <https://doi.org/10.1017/jfm.2021.552>.
- [257] Hao, J., Fan, J., Cao, S., and Wen, C.-Y., “Three-dimensionality of hypersonic laminar flow over a double cone,” *J. Fluid Mech.*, Vol. 935, 2022, p. A8. <https://doi.org/10.1017/jfm.2021.1137>.
- [258] Cao, S., Hao, J., Klioutchnikov, I., Wen, C.-Y., Olivier, H., and Heufer, K. A., “Transition to turbulence in hypersonic flow over a compression ramp due to intrinsic instability,” *J. Fluid Mech.*, Vol. 941, 2022, p. A8. <https://doi.org/10.1017/jfm.2022.277>.
- [259] Schmisser, J., Collicott, S., and Schneider, S., “Laser-generated localized freestream perturbations in supersonic and hypersonic flows,” *AIAA J.*, Vol. 38, No. 4, 2000, pp. 666–671.
- [260] Graziosi, P., and Brown, G. L., “Experiments on stability and transition at Mach 3,” *J. Fluid Mech.*, Vol. 472, 2002, pp. 83–124. <https://doi.org/10.1017/s0022112002002094>.
- [261] Craig, S. A., and Saric, W. S., “Crossflow instability in a hypersonic boundary layer,” *J. Fluid Mech.*, Vol. 808, 2016, pp. 224–244. <https://doi.org/10.1017/jfm.2016.643>.
- [262] Saric, W. S., West, D. E., Tufts, M. W., and Reed, H. L., “Experiments on discrete roughness element technology for swept-wing laminar flow control,” *AIAA J.*, Vol. 57, No. 2, 2019, pp. 641–654. <https://doi.org/10.2514/1.j056897>.
- [263] Charru, F., *Hydrodynamic instabilities*, Cambridge University Press, 2011. <https://doi.org/10.1017/cbo9780511975172>.
- [264] Milne-Thomson, L. M., *Theoretical hydrodynamics*, Macmillan Education UK, 1968. <https://doi.org/10.1007/978-1-349-00517-8>.
- [265] Couette, M., “Distinction de deux régimes dans le mouvement des fluides,” *J. Phys. Theor. Appl.*, Vol. 9, No. 1, 1890, pp. 414–424. <https://doi.org/10.1051/jphysap:018900090041401>.
- [266] Dean, W. R., “Fluid motion in a curved channel,” *Proc. R. Soc. London.*, Vol. 121, No. 787, 1928, pp. 402–420. <https://doi.org/10.1098/rspa.1928.0205>.

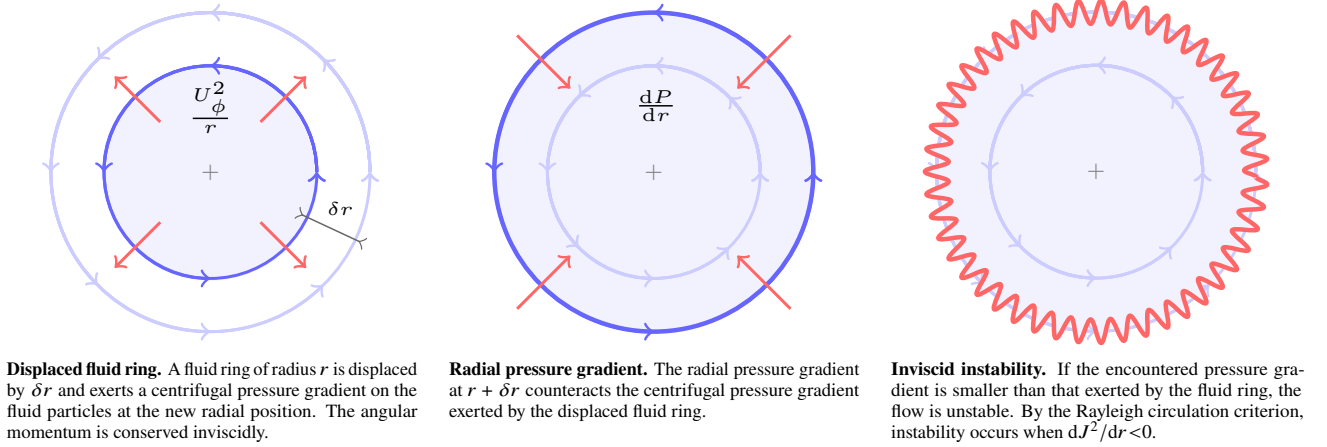

**Fig. 26** Schematic of the inviscid centrifugal imbalance responsible for Görtler instability.

### A. The fundamental mechanism behind centrifugal instability

In this Appendix, we discuss the fundamental physical mechanism that is responsible for the centrifugal instability, at the base of the Görtler instability at any Mach number. Rayleigh [22] carried out the first theoretical study of centrifugal instability under the assumption of inviscid flow. He discovered that a necessary and sufficient condition for the existence of an inviscid axisymmetric instability is  $dJ^2/dr < 0$ , where  $J = rU_\phi(r)$  is the angular momentum per unit mass,  $r$  is the radial coordinate and  $U_\phi$  is the velocity component along the azimuthal direction  $\phi$  (quantities used herein are non-dimensional). This condition is known as the Rayleigh circulation criterion.

This inviscid instability is related to an imbalance between the centrifugal acceleration and the radial pressure, caused by the curvature of boundary-layer streamlines. The angular momentum due to the curved streamlines cannot be balanced by the small radial pressure gradient, as shown in the schematic of figure 26. This imbalance can be explained as follows [23, 263]. We consider a rotating fluid and, in particular, a ring of rotating fluid particles with initial velocity  $U_\phi(r)$ , which, owing to fluctuations, is displaced by a distance  $\delta r$ . Under the assumption of inviscid flow, Lord Kelvin's circulation theorem applies [264], that is, the circulation of the fluid ring,  $2\pi rU_\phi$ , is conserved over time, and therefore the angular momentum  $J = rU_\phi$  is also conserved. The fluid ring at the new radial position  $r + \delta r$  thus has the same angular momentum it had at the starting position  $r$ ,  $J(r + \delta r) = J(r)$ . The fluid ring exerts a centrifugal pressure on the fluid particles at the new radial position and a restoring radial pressure gradient is necessary to guarantee the stability of the fluid ring. In the radial momentum equation, the radial pressure gradient that balances the centrifugal term is  $\rho^{-1}dP/dr = U_\phi^2/r = J^2/r^3$  (where  $P$  is the fluid pressure and  $\rho$  is the fluid density), and thus the centrifugal pressure gradient generated by the fluid ring on the encountered fluid particles is  $J^2(r)/(r + \delta r)^3 = [rU_\phi(r)]^2/(r + \delta r)^3$ . This radial term is equal to the pressure gradient required for stability. When expanding by a distance  $\delta r$ , the fluid ring encounters the pressure gradient  $[rU_\phi(r + \delta r)]^2/(r + \delta r)^3$ . If this existing pressure gradient at  $r + \delta r$  is larger than that required to counteract the centrifugal pressure gradient induced by the displaced fluid ring, i.e.,  $[rU_\phi(r + \delta r)]^2 > [rU_\phi(r)]^2$ , the flow is stable. This inequality agrees with the Rayleigh circulation criterion. If the restoring pressure does not increase with the radius at the required rate to balance the centrifugal pressure, this imbalance leads to flow instability.

For the Couette flow between two coaxial cylinders [265], it is straightforward to verify that the laminar azimuthal profile satisfies the Rayleigh circulation criterion of stability when the outer cylinder is in motion and the inner cylinder is stationary. When viscous effects are taken into account, the condition for centrifugal instability becomes necessary as the flow is stable at small Reynolds numbers. The viscous centrifugal instability between two coaxial cylinders was analyzed for the first time by Taylor [26]. In Taylor [26]'s milestone study, the purely azimuthal flow was investigated theoretically and experimentally and found to be unstable when the speed of the inner cylinder exceeds a critical value. The instability manifests itself in various forms, one of which is the appearance of persistent vortices aligned in the flow direction. The term Taylor instability is now in use. The Dean instability is related to the Taylor-Couette instability because it is also caused by the same inviscid imbalance and

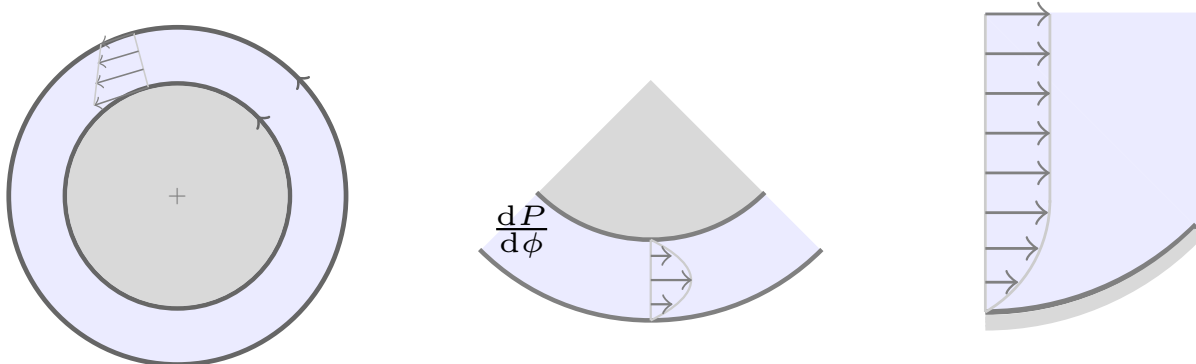

**Taylor-Couette flow.** Two concentric cylinders rotate and generate a flow between them.

**Dean flow.** An azimuthal pressure gradient generates a flow in a curved channel with fixed walls.

**Görtler flow.** A free-stream boundary layer develops over a concave fixed plate.

**Fig. 27 Schematic of the three main flows subject to inviscid centrifugal instability.**

characterized by elongated vortices, although the flow is generated by an azimuthal pressure gradient between two stationary coaxial cylinders and not by a moving wall [266]. The Dean instability may also be observed along curved pipes [142]. Figure 27 shows a schematic of Taylor-Couette, Dean and Görtler flows, dominated by the inviscid centrifugal instability.

Although the fundamental inviscid instability mechanism is the same in Görtler, Taylor-Couette and Dean flows, important differences must be noted. The Görtler instability is more complex than the Taylor-Couette and Dean instabilities because a free-stream boundary layer is nonparallel and two dimensional, i.e., it varies along the streamwise direction, featuring streamwise and wall-normal velocity components. The initial conditions near the leading edge of the concave surface therefore play a crucial role for the Görtler instability. The Taylor-Couette and Dean base flows between coaxial cylinders are instead parallel to the walls and independent from the azimuthal direction. Furthermore, being unbounded, the boundary-layer instability over a concave wall is strongly influenced by the characteristics of the free-stream flow. The Görtler instability is also more relevant in applied fluid mechanics research than the Taylor-Couette and Dean instabilities because of its prevalence in fluids engineering systems, as discussed in the Introduction. It concerns flows at all Mach numbers, while the Taylor-Couette and Dean instabilities are essentially restricted to the incompressible regime.

## Biographies

**Dongdong Xu** is a Research Associate in the Department of Mechanical Engineering at The University of Sheffield. He received his B.S. degree in Theoretical and Applied Mechanics from Lanzhou University and completed his Ph.D. degree in Fluid Mechanics at Tianjin University. His research interests include receptivity theory, Görtler instability, secondary instability and wall-bounded turbulence.

**Pierre Ricco** is a Professor of Fluid Mechanics in the Department of Mechanical Engineering at the University of Sheffield with experience in stability of boundary layers and turbulent drag reduction. He holds a five-year-long Mechanical Engineering degree from Politecnico di Milano, an MSc from the University of Texas at Austin, and a post-graduate diploma from the von Kármán Institute for Fluid Dynamics. He obtained his Ph.D. in Applied Mathematics from Imperial College London in 2006 and was a Research Fellow at the Institute for Mathematical Sciences at Imperial from 2005 and 2007. He was a Lecturer at King's College London between 2007 and 2011, when he moved to the University of Sheffield. His research has been supported by the European Union, the UK Research Council, the Taiho Foundation, the A\*star Programme in Singapore, the US Air Force, Airbus, and the Iraqi government. He has developed his research experience through direct numerical simulations, asymptotic methods, and experiments. His research interests include active control of transitional and turbulent boundary layers, stability and receptivity of compressible boundary layers, stability of pipe flows, lubrication theory, and multiphase flows. In 2003, he received the first O. Reynolds Prize as best UK-based young fluid mechanics researcher.

**Lian Duan** is an Associate Professor and holder of the Honda Endowed Chair in transportation in the Department of Mechanical and Aerospace Engineering at The Ohio State University. Before joining The Ohio State University in September 2019, he was an Assistant Professor at Missouri University of Science and Technology from 2013 to 2019 and worked as a research scientist at the National Institute of Aerospace from 2010 to 2013. He received his Ph.D. in Mechanical and Aerospace Engineering from Princeton University in 2011. Duan has held research grants with government and industries on topics including (but not limited to) compressible turbulence, flow instability and transition, turbulence modeling and control, high-performance and data-driven computing, and automotive aerodynamics. The significance of his research has been recognized with several accolades including the 2017 Henry J. E. Reid Award, 2014 Air Force Office of Scientific Research (AFOSR) Young Investigator Award, 2015 AIAA St. Louis Section Young Professional Engineer Award, and multiple mentions in the annual highlights of Fluid Dynamics research in Aerospace America. Duan is an Associate Fellow of AIAA.