



Deposited via The University of York.

White Rose Research Online URL for this paper:

<https://eprints.whiterose.ac.uk/id/eprint/205904/>

Version: Accepted Version

Article:

Dawson, John F, Marvin, Andy C, Catrysse, Johan et al. (2023) An Overview of the New IEEE P2716 Guide to Board Level Shielding. *Electromagnetic Compatibility Magazine*, IEEE. pp. 85-93. ISSN: 2162-2264

Reuse

Items deposited in White Rose Research Online are protected by copyright, with all rights reserved unless indicated otherwise. They may be downloaded and/or printed for private study, or other acts as permitted by national copyright laws. The publisher or other rights holders may allow further reproduction and re-use of the full text version. This is indicated by the licence information on the White Rose Research Online record for the item.

Takedown

If you consider content in White Rose Research Online to be in breach of UK law, please notify us by emailing eprints@whiterose.ac.uk including the URL of the record and the reason for the withdrawal request.

An Overview of the new IEEE P2716 Guide to Board Level Shielding

John F Dawson, *Member, IEEE*; Andy C Marvin, *Life Fellow, IEEE*; Johan Catrysse, *Life Senior Member, IEEE*;
Yoeri Ariën, *Member, IEEE*; Davy Pissoort, *Senior Member, IEEE*

Abstract—This article introduces the IEEE Standard P2716 “for”. After introducing the peculiarities of board level shielding, the shielding effectiveness |(SE) measurement methods in the guide are summarised, and some Board Level Shield results from a round robin conducted by the P2716 group are presented.

Index Terms—Electromagnetic Shielding, Standards, Board Level Shielding

I. INTRODUCTION

THE IEEE Standards association has just published IEEE Standard P2716 “Guide for the Characterization of the Effectiveness of Printed Circuit Board Level Shielding” [1]. This is the first standards document that considers the specific topic of board level shielding.

Historically shielding standards began with the need to measure the shielding effectiveness of large enclosures such as screened rooms (e.g. MIL std. 285 [2] later replaced by the IEEE Std. 299 [3]). In such cases full-size EMC measurement antennas may be used and will easily fit in a room sized enclosure. With the need to measure the shielding of smaller equipment enclosures leading to the development of IEE Std. 299.1 for smaller enclosures [4] having dimensions between 2 m and 0.1 m. IEEE Std. 299.1 recommends the use of electrically small monopole antennas for these small enclosures. Board level shields typically have dimensions less than 0.1 m and the smallest available are only a few millimeters in size. This severely limits the choice of antenna inside the shield.

A. Board level shielding

Board level shielding allows sensitive circuits, or significant emitters of radiation, to have their own shielding directly on the printed circuit board (PCB), such as shown in Fig. 1. This can be more cost effective than shielding the whole board or equipment as a low-cost plastic enclosure can be used. It also means that sensitive components on a board can be shielded from the emitters on the board.

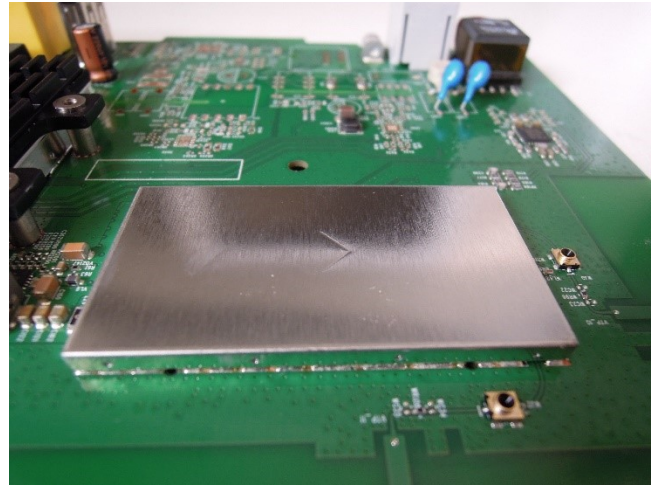

Fig. 1. Board level shield on a Wi-Fi router.

II. BOARD LEVEL SHIELDING MEASUREMENT

The shielding effectiveness (SE) of a Board Level Shield (BLS) is typically defined as the ratio of power received by an antenna with no BLS present, P_{wo} , to the power received by the same antenna with the BLS present, P_{wi} :

$$SE = \frac{P_{wo}}{P_{wi}}. \quad (1)$$

A. PCB test fixture

In order to measure the SE of a BLS it is mounted on a test fixture. Two types of test fixture are considered in IEEE Standard P2716. The first type aims to replicate the installation of the BLS on a PCB. Fig. 2 shows an example of such a fixture with a two-part shield attached. The BLS frame is soldered to a copper outline on the top surface of the PCB, that is connected to the ground plane on the bottom of the PCB by means of a large number of vias. A short PCB trace is used as an antenna inside the shield to enable the measurement of SE. It is important to note that some energy may enter or leave the shield due to the gaps in the vias between the top and bottom of the board and this may influence the SE measurement if the via spacing is too large.

This work was supported by the IEEE Standards Association and the institutions of the P2716 group members, with shield samples donated by a Laird and Wurth Elektronik.

John F. Dawson and Andrew C. Marvin are with the School of Physics, Engineering and Technology, University of York, UK (john.dawson, andy.marvin@york.ac.uk).

Yoeri Ariën is with SEM Belgium (yoeri.arien@schlegelemi.com)
Johan Catrysse and Davy Pissoort are with KU Leuven, Belgium (davy.pissoort@kuleuven.be).



a) with shield lid removed showing stripline

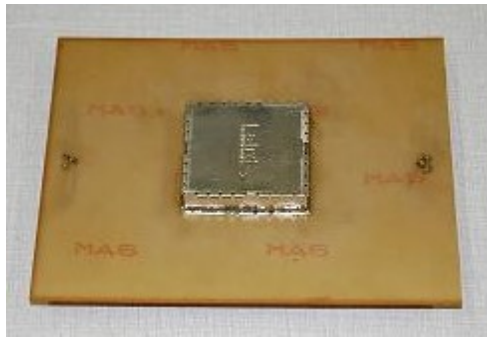

b) with shield lid in place

Fig. 2. A typical BLS PCB test fixture

The second type of jig mounts the BLS as a cover to an aperture in an enclosure. Fig. 3 shows an example of this type of jig, which is fabricated as a custom plate with an aperture which is slightly smaller than the BLS, designed to fit over a larger general-purpose SE measurement aperture. The BLS is clamped to the plate by means of a non-conductive screw that presses on the BLS. The plate is attached to the main enclosure by metallic screws with a clamping frame for stiffness and a conductive gasket to minimise leakage around the plate edge.

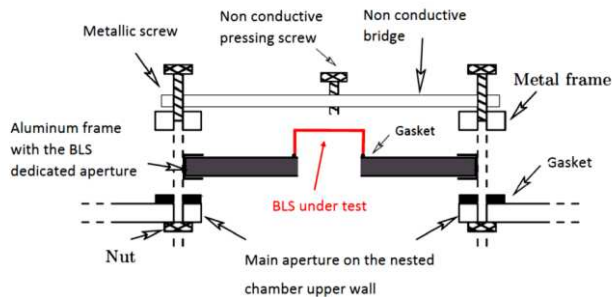
**Fig. 3.** A typical BLS aperture cover test fixture

With this type of fixture the SE measurement can be used to measure the leakage of energy through BLS directly but does not aim to replicate the effect of the PCB mounting.

B. Stripline test method

Here a PCB test fixture such as shown in Fig. 2 is placed in a parallel plate stripline such as shown in Fig. 4 and Fig. 5. This is based on the stripline method used in IC EMC standards [5] and [6], and measurement of conductive gasket performance [7].

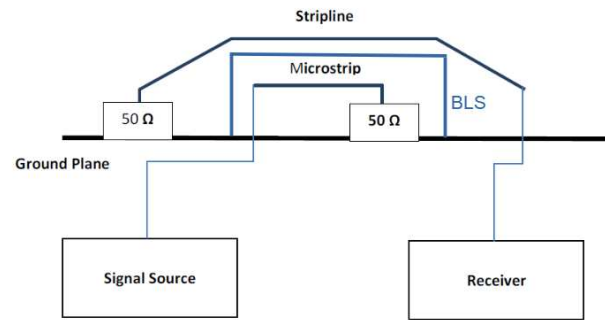
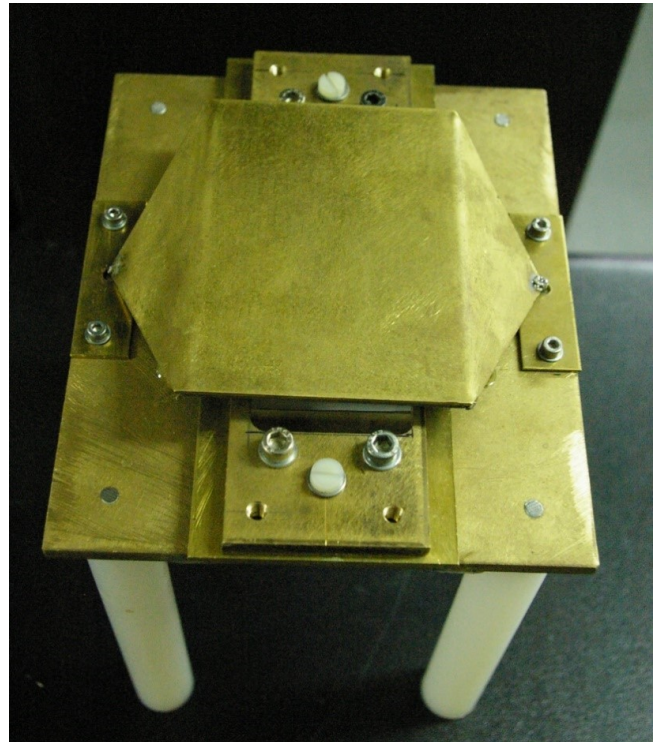
**Fig. 4.** Cross section of BLS stripline setup**Fig. 5.** Stripline for BLS SE measurement

The BLS is illuminated by the “plane” wave travelling in the stripline, and the shielding effectiveness defined as in (1).

This method has the advantage of providing a compact test environment and has been found to correlate well with the reverberation chamber method described below. However, as the shield is only illuminated with a wave from a single direction, with a single polarisation the measured SE may vary with the orientation of the shield. The method can be used from very low frequencies and the stripline has been shown to give useful results up to 40 GHz for gasket measurements [7].

C. Reverberation chamber method

Here a board level test fixture such as shown in Fig. 2 is placed in a reverberation chamber. A reverberation chamber is an electrically large conductive shielding enclosure with some means of altering the electromagnetic modal structure, such as a mechanical stirrer, operated in a frequency range where a significant number of modes are excited at any given frequency [8]. The coupling between the antenna under the BLS and an external antenna is measured as shown in Fig. 6. The received

power levels are averaged over a number of stirrer positions so (1) becomes:

$$SE = \frac{\langle P_{wo} \rangle}{\langle P_{wi} \rangle} \quad (2)$$

where $\langle P \rangle$ indicates an average over all stirrer positions [9]. Some alternative definitions for SE and indication of its variability as the chamber is stirred are described in [10].

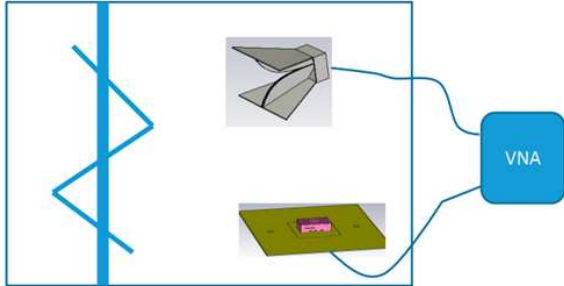

Fig. 6. Reverberation chamber setup for BLS SE

This method has the advantage that the shield is illuminated from all directions with all polarisations and the mean SE result tends to be independent of the detailed arrangement of the jig, antenna and cables in the chamber, and the statistical variation as the chamber is stirred can be used to give a measure of the variability of shielding over a range of applications and illuminations. The shield is mounted on a PCB and the configuration is similar to that in actual use. However the chamber is larger and the measurement more complex and time consuming than the stripline method above. The lowest useable frequency of the reverberation chamber (typically a few hundred megahertz for medium size chambers), limits the measurement frequency range. The upper frequency limit of measurement is likely to be bounded by the point at which chamber losses limit the reverberation chamber. Reverberation chamber measurements have been demonstrated up to 60 GHz [11].

D. Dual Reverberation chamber method

In this method the BLS is mounted over an aperture in the wall between two reverberation chambers using a fixture such as that shown in Fig. 3. This can be done by placing a small inner (nested) chamber in a larger outer chamber (Fig. 7) or by building two chambers with a common wall.

In this method a SE value may be measured by exciting an antenna in one chamber and measuring the power received in the other as in (2). In practice the SE measured will depend on the Q-factor of the particular chambers used and does not directly correspond to the use case on a PCB due to the different geometry. A four antenna measurement method as illustrated in Fig. 7 allows for any chamber effect to be removed and is described in detail in IEEE Standard P2716, Annex C [1] based on the work of Holloway et al [12]. The method is also capable of measuring the transmission cross-section of the BLS, a metric which can be used to determine the shielding performance of the shield independent of how it is used [13]. In practice if the aperture of the shielding jig is small compared to the size of the chambers, the two antenna method gives a good estimate of the SE.

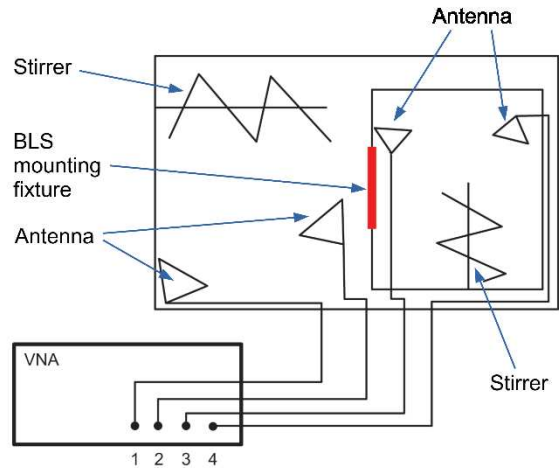

Fig. 7. Dual reverberation chamber method

E. GTEM Method

It is also possible to measure the SE of a BLS by placing the BLS in an aperture of an enclosure illuminated by a plane wave. The method described in IEEE Standard P2716 [1] uses a GTEM cell [14] to generate the plane wave but other TEM cells, anechoic chambers etc. would also be viable.

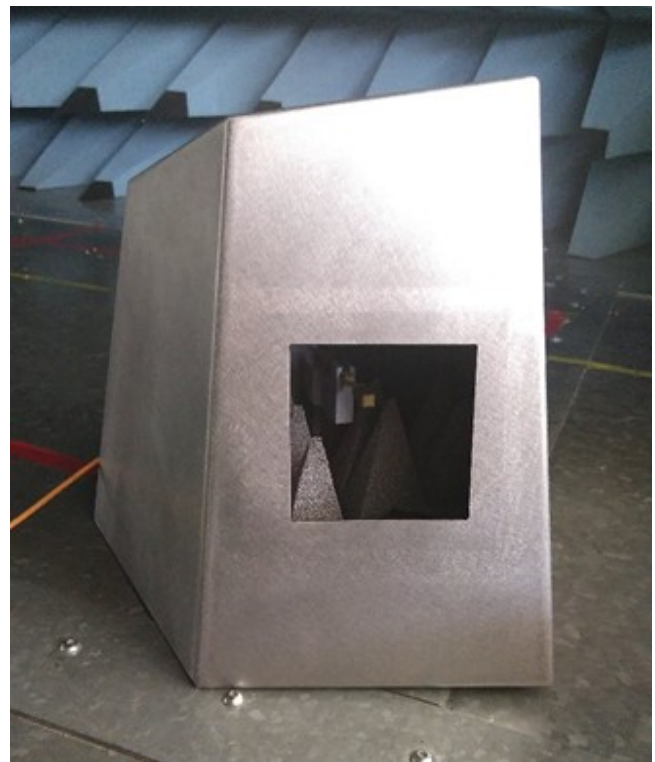

Fig. 8. Test enclosure for BLS measurement in GTEM

The enclosure used in this case is an asymmetrical metal box without any parallel or orthogonal faces. The box is shown in Fig. 8. The shape was chosen to maximise the spectral density of modes which can propagate. The enclosure is also loaded with radio absorptive material (RAM) to minimise any resonant effects. Individual mounting plates were fabricated for each BLS to cover the enclosure aperture as shown in Fig. 9.

The SE for this method is calculated as the ratio of power received by an antenna in the enclosure without the shield attached to the mounting plate, to that with the shield attached as in (1).

In this method the SE measured depends on the details and loading of the enclosure used, so is most suitable for comparing the SE of a number of shields. As with the stripline methods, if only a single direction of illumination and/or polarisation is used the value of SE measured may also depend on the orientation of the shield with respect to the incident wave. The method is limited in frequency at the lower end by the size at which the test enclosure is able to propagate energy internally (about half a wavelength of the largest cross-section), and at the upper end by the formation of Higher order modes in the GTEM cell (typically 1GHz, depending on the GTEM cell size and quality) or transmission line used. If the test fixture were used in an anechoic chamber, then the lower and upper frequency are limited by chamber performance.

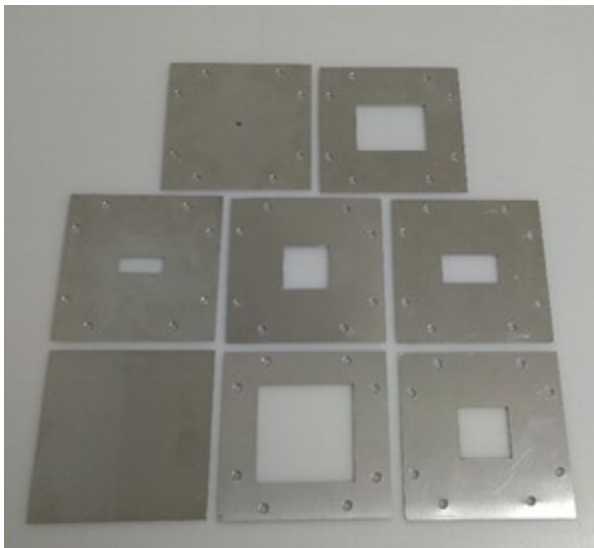

Fig. 9. BLS mounting fixtures, and reference blanking plate (bottom left) for GTEM enclosure.

III. BLS SHIELDING ROUND ROBIN

A. Methodology

A set of 6 identical types of BLS were sent to a number of labs where the various methods described above were used to measure the SE of each BLS. Each lab received its own set of shields so some of the variability in the measurements may be accounted for in manufacturing tolerances resulting in some differences between the shields. It was not possible for every lab to measure every sample.

TABLE I. DESCRIPTION OF KEY FOR RESULTS GRAPHS

Key	Description
RC N	Reverberation chamber N
Stripline N	Stripline N
Dual RC N	Dual reverberation chamber N
Dual VIRC	Dual Vibrating Intrinsic Reverberation Chamber [15]
GTEM L/H	GTEM Low/High frequency range

B. Measurement dynamic range

The dynamic range of a measurement determines the maximum SE that can be measured and depends on the equipment used, and its settings, as well as the type and detail of the test setup. The first factor that determines the dynamic range of any SE measurement is the ratio of the source power to the noise power in the device that measures the received power. The noise power in the measurement device may be reduced by decreasing the measurement bandwidth, with a concomitant increase in measurement time. The second factor is the transmission loss in the jig which reduces the power at the receiver, and hence the dynamic range. Another important factor which may further reduce the measurement range in shielding measurements is the leakage between source and receiver that occurs due to imperfections in the shielding of the cables, connectors, chambers, and mounting jigs. Care must be taken to minimise this effect.

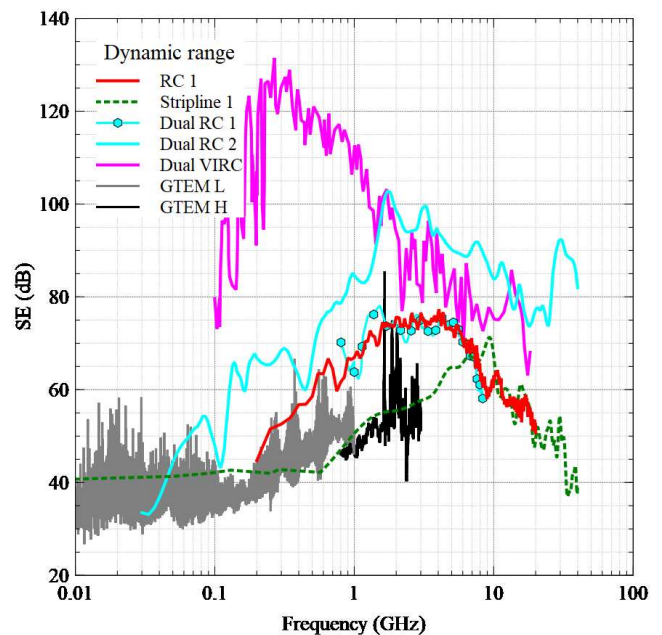

Fig. 10. Measurement dynamic range, as maximum measurable SE achieved in the round robin

Fig. 10 shows the dynamic range achieved by some of the measurement setups used in the round robin. It can be seen that most of the methods here achieved over 70dB at best, but in all methods the dynamic range tends to reduce at lower frequencies due to higher coupling losses between the antennas, and at high frequencies due to increased chamber losses. In all the methods the dynamic range tends to be poor at low frequencies due to the sensitivity of the small antenna inside the BLS decreasing as the frequency is reduced.

C. Sample 1 SE Results

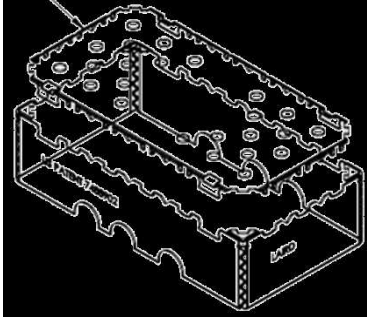

Fig. 11. Sample 1, 20.4 mm x 38.4 mm x 10.2mm BLS with tear off lid.

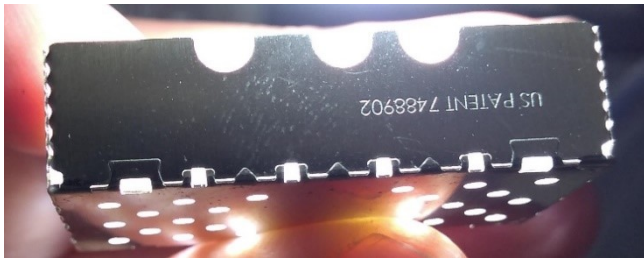

Fig. 12. Sample 1 with back illumination showing gaps where lid joins and corners of the sides

The first sample is shown in Fig. 11 and Fig. 12. It is designed for surface mount. It has a number of gaps at the corners between the sides, and between the top and sides, as well as ventilation holes in the top and sides. All of these apertures are a major factor in determining the SE in operation. We anticipate that the separation of the gaps may be affected by manufacturing and installation tolerances and hence will affect the reproducibility of SE measurements.

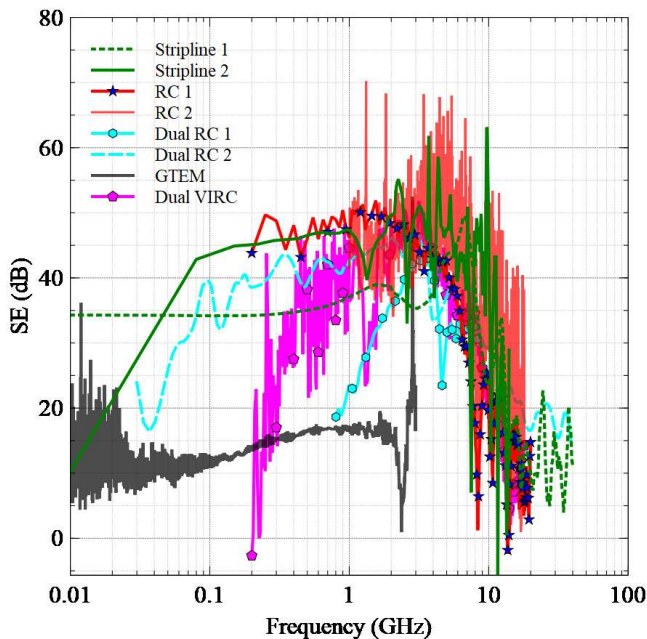

Fig. 13. Sample 1 SE measured in the round-robin

Fig. 13 shows the SE measured in the various labs using the methods described above. It can be seen that the stripline and

RC method show good correlation. The dual RC measurements show similar behaviour but with some differences in the level measured. The GTEM method shows a much lower level of SE.

D. Sample 2 SE Results

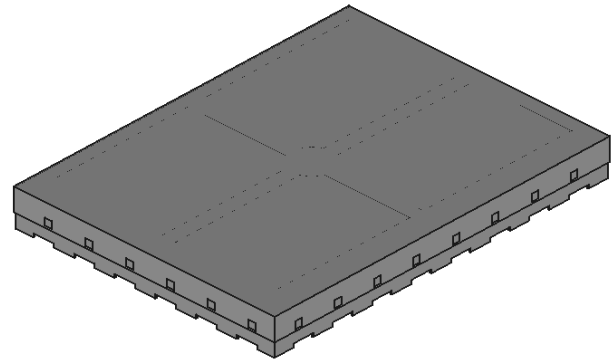

Fig. 14. Sample 2, 51.2 mm x 38.4 mm x 5.24mm BLS with clip on lid

Sample 2 consists of a frame with a clip-on lid (Fig. 14). The frame has a castellated base designed for surface mount. The lid has 8 dimples on each side, which mate with holes in the frame. Any coupling into the shield is via the castellations and the gaps between the dimples connecting lid and frame.

Fig. 15 shows the SE measured during the round-robin tests. Most of the measurements correspond well at frequencies above 2 GHz, but the GTEM and Dual RC 1 give a much lower SE.

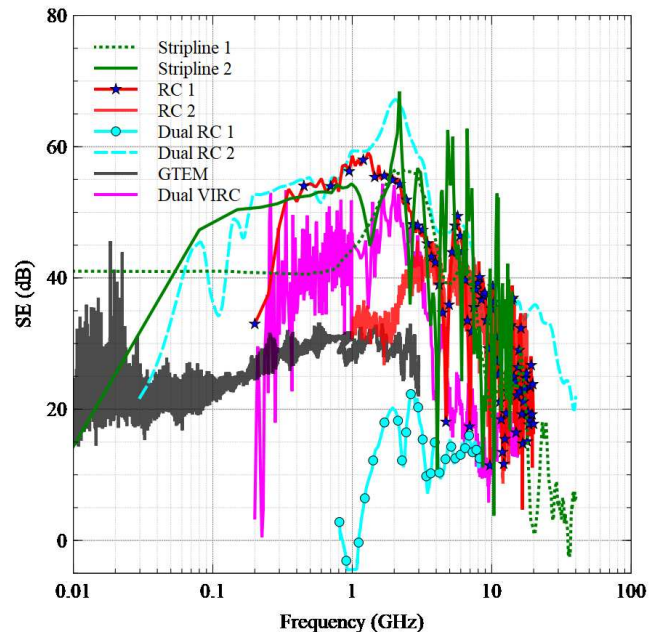

Fig. 15. Sample 2 SE measured in the round-robin

E. Sample 3 SE results



Fig. 16. Sample 3, 30 mm x 11 mm x 2mm

Sample 3 (Fig. 16) is a small surface mount shield. The measured SE results (Fig. 17) correlate well above 4 GHz for most of the techniques, but show considerable divergence below 4 GHz. As with previous samples, the GTEM method shows a lower SE value than the other techniques.

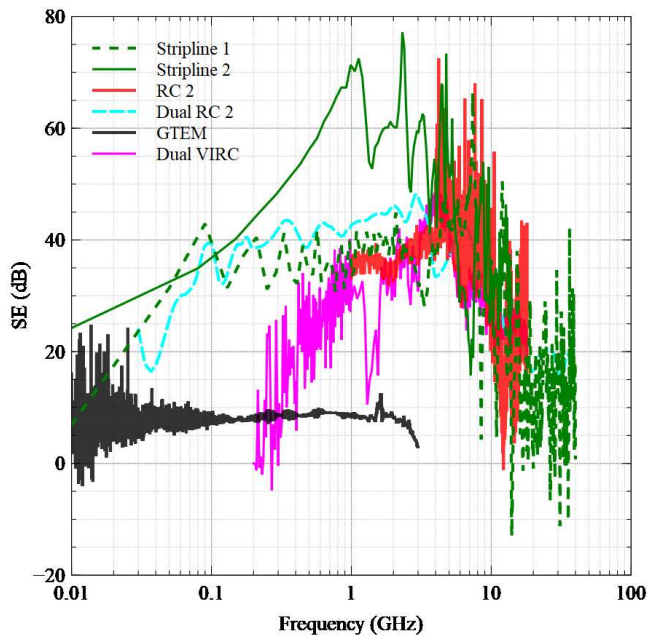

Fig. 17. Sample 3 SE measured in the round-robin

F. Sample 4 SE Results

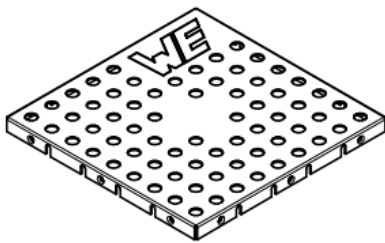

Fig. 18. Sample 4, 30 mm x 30 mm x 3mm BLS

Sample 4 (Fig. 18) is a surface mount shield with ventilation holes and with some castellation on the edges.

The form of the measured SE (Fig. 19) correlates well across the range but there are substantial differences in the actual levels measured across the range of measurements.

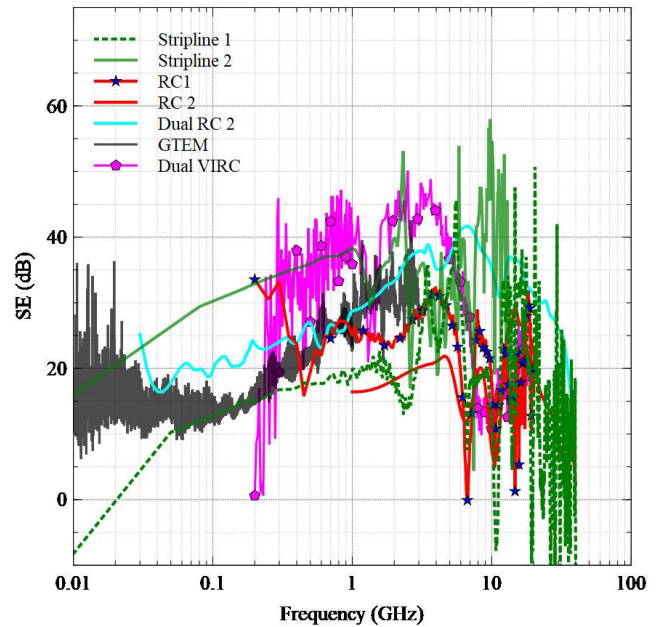

Fig. 19. Sample 4 SE measured in the round-robin

G. Sample 5 measured SE

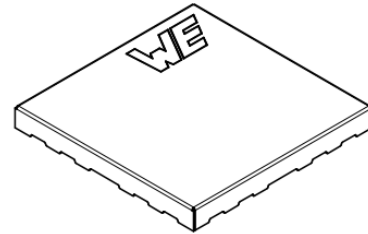

Fig. 20. Sample 5, 30 mm x 30 mm x 3mm BLS

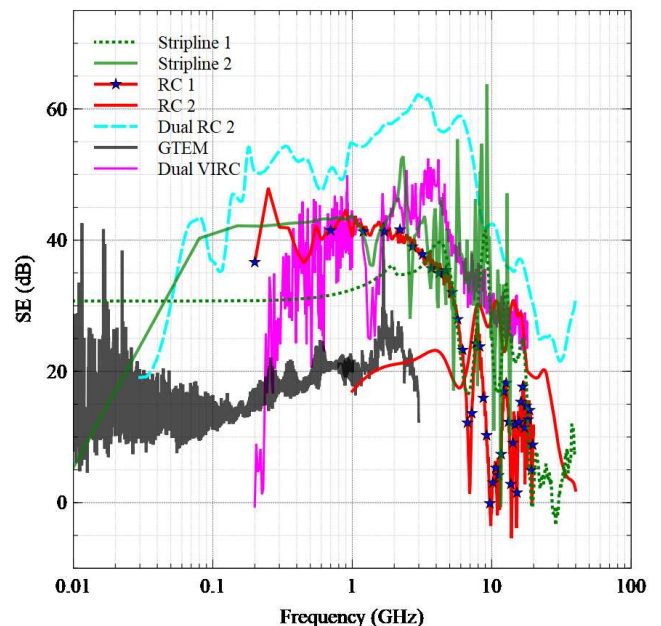

Fig. 21. Sample 5 SE measured in the round-robin

Sample 5 is also a surface mount shield, with castellations on the edges which attach to the board (Fig. 20).

The SE measurements correspond well for the striplines, RC 1 and the Dual VIRC, whereas Dual RC 2 gives a substantially higher value. The GTEM cell and RC 2 give substantially lower values.

H. Sample 6 measured SE

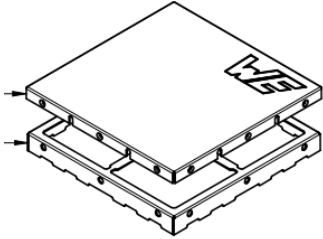

Fig. 22. Sample 6, 60 mm x 60 mm x 3mm BLS

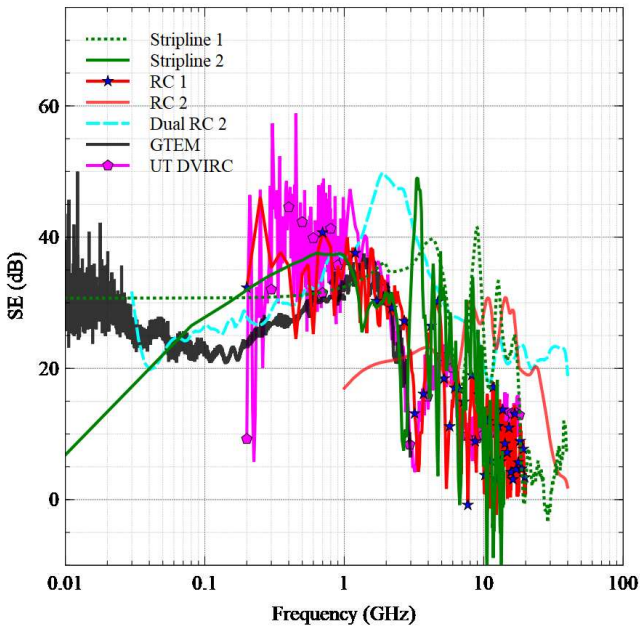

Fig. 23. Sample 6 SE measured in the round-robin

Sample 6 is a two part shield of the same construction as Sample 2, but larger in size.

For this sample the measured SE values agree well over much of the frequency range for all the methods.

I. Sample 7 measured SE

Sample 7 is a very small shield and most of the labs were unable to measure it with their existing jigs.

Whilst the stripline 2 measurement shows a SE of about 35 dB over much of the frequency range, the GTEM and Dual VIRC show zero shielding, with negative excursions.

V. CONCLUSION

It should be noted that the different methods of measuring SE are not all measuring the same scenario so the same results for measured SE should not be expected. The stripline and reverberation chamber methods are the closest approximations

to the typical use case, and correlate well in some cases, though significant discrepancies can be seen in places. The principal difference between the two methods is that the stripline illuminates the shield with only one direction and polarisation, whereas the RC illuminates with a large number of directions and polarisations which are averaged to give the overall SE value. Some differences should be expected. The dual RC, VIRC and GTEM methods measure the transmission through the shield mounted in a wall between two chambers, which is quite different from the typical on-PCB use case. However, all the methods indicate the leakage due to imperfections in the shield such as holes, seams and joints.

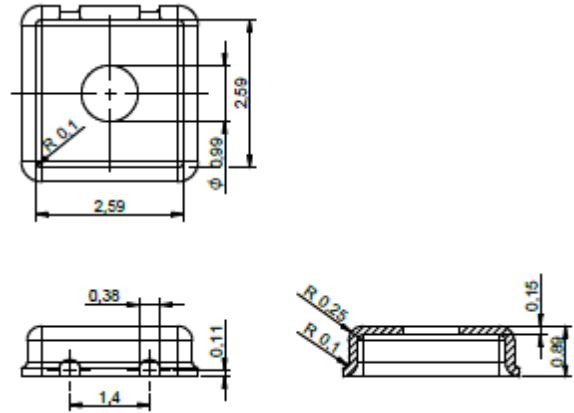

Fig. 24. Sample 7, 2.6mm x 2.6mm x 0.9mm

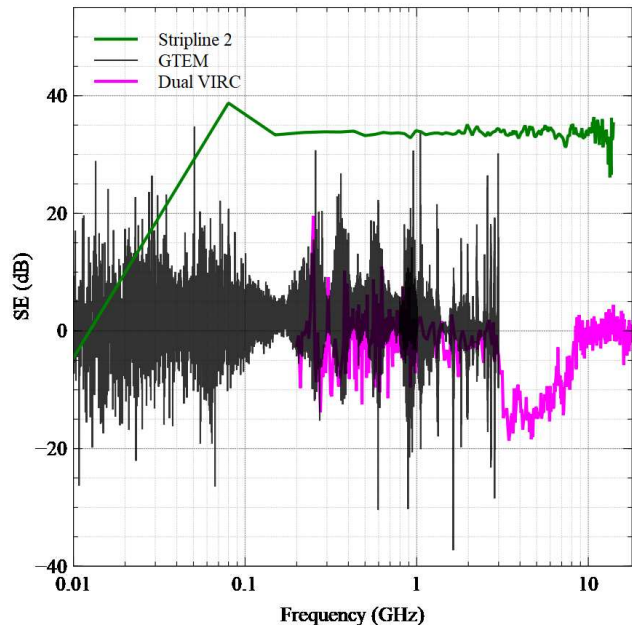

Fig. 25. Sample 7 SE measured in the round-robin

A significant challenge with all these measurements is the attachment of the shield to the jig. The shield can be soldered to the jig, and this gives a good performance, but is extremely difficult to remove the shield once soldered and also to remove the solder sufficiently well that another shield can be soldered in place without distortion. Also, solder may partially fill castellations on the mounting surface, which alters the SE. Simply clamping the shield to the jig seems an attractive

alternative, but as the shields are mostly thin metal structures, it is difficult to ensure that the shield is not distorted, and that good contact is made with the jig [15]. Distortion of the shield can open, or close joints and seams, and also open up gaps in the mounting edge, all of which affect the SE. The use of silver conductive paint has been shown to be an effective solution for jig re-use [16], but again care is needed not to fill holes with the paint and the joint is easily fractured when handling. The use of a gasket on the base may be an alternative solution but has not been tested in our work. For the methods where the shield is mounted on a printed circuit board, leakage through the vias connecting the top and bottom board planes around the edge of the shield and around the connectors may also be sources of leakage [17].

IV. ACKNOWLEDGMENT

The Authors would like to thank all those who contributed to the IEEE P2716 Board level shielding project and in particular: Dominic Haerke, David Inman, Frank Leferink, Valter Mariani Primiani, Franco Moglie, Cornelia Reschka, Brian She, Adrian Suarez Zapata, David Inman, Heyno Garbe, Robert Vogt-Ardatje, Vasiliki Gkatsi, Hans Schipper, and Haiyan Xie, who took part in the measurement round robin and provided material which is incorporated in this article. Also to Laird, and Wurth Elektronik, who provided sample BLS.

REFERENCES

- [1] 'IEEE Approved Draft Guide for the Characterization of the Effectiveness of Printed Circuit Board Level Shielding', IEEE P2716/D2, April 2022, pp. 1–46, Dec. 2022. [Online]. Available: <https://ieeexplore.ieee.org/document/9913397>
- [2] 'MIL-STD-285 - Military standard attenuation measurements for enclosures, electromagnetic shielding, for electronic test purposes', Jun. 1956 [Online]. Available: <http://www.tscm.com/reference.html>
- [3] 'IEEE standard method for measuring the effectiveness of electromagnetic shielding enclosures', IEEE Std 299-2006 (Revision of IEEE Std 299-1997), pp. 1–52, 2007, doi: 10.1109/IEEESTD.2007.323387.
- [4] IEEE standard method for measuring the shielding effectiveness of enclosures and boxes having all dimensions between 0.1 m and 2 m', IEEE Std 299.1-2013, pp. 1–96, Jan. 2014, doi: 10.1109/IEEESTD.2014.6712029.
- [5] IEC 61132-8: "Integrated Circuits – measurements of electromagnetic immunity – part 8: measurement of radiated immunity – IC stripline method"
- [6] IEC 61967-8: "Integrated Circuits – measurements of electromagnetic emissions – part 8: measurement of radiated emissions – IC stripline method"
- [7] SAE, ARP6248: "Stripline Test Method to Characterize the Shielding Effectiveness of Conductive EMI Gaskets up to 40 GHz", 2022
- [8] Corona, P.; Ladbury, J. & Latmiral, G. , "Reverberation-chamber research-then and now: a review of early work and comparison with current understanding" , IEEE Transactions on Electromagnetic Compatibility , vol. 44, no. 1 , 87-94 , Feb. , 2002 , DOI: 10.1109/15.990714
- [9] Holloway, C.; Hill, D.; Sandroni, M.; Ladbury, J.; Coder, J.; Koepke, G.; Marvin, A. & He, Y. , "Use of Reverberation Chambers to Determine the Shielding Effectiveness of Physically Small, Electrically Large Enclosures and Cavities", Electromagnetic Compatibility, IEEE Transactions on , vol. 50, no. 4 , 770-782 , Nov, 2008 , DOI: 10.1109/TEMC.2008.2004580C.
- [10] Marvin, A.; Dawson, J.; Dawson, L.; Xie, H. & Venkateshaiah, A. , "An Experimental Study of the Variability of the Shielding Effectiveness of Circuit Board Shields", 2020 International Symposium on Electromagnetic Compatibility - EMC EUROPE , 2020 , Available: <https://eprints.whiterose.ac.uk/160135/>
- [11] A. K. Fall et al., 'Design and Experimental Validation of a Mode-Stirred Reverberation Chamber at Millimeter Waves', IEEE Transactions on Electromagnetic Compatibility, vol. 57, no. 1, pp. 12–21, Feb. 2015 DOI: 10.1109/TEMC.2014.2356712
- [12] Holloway, L., D. A. Hill, J. Ladbury, G. Koepke, and R. Garzia, "Shielding effectiveness measurements of materials using nested reverberation chambers," IEEE Transactions on Electromagnetic Compatibility, vol. 45, no. 2, pp. 350–356, May 2003, <http://dx.doi.org/10.1109/TEMC.2003.809117> .
- [13] Dawson, J. F., A. C. Marvin, M. Robinson, and I. D. Flintoft, "On the Meaning of Enclosure Shielding Effectiveness", 2018 International Symposium on Electromagnetic Compatibility - EMC EUROPE, 746–751, 27–30 August, 2018, , Available: <https://eprints.whiterose.ac.uk/130815/>
- [14] C. Groh, J. P. Karst, M. Koch, and H. Garbe, 'TEM waveguides for EMC measurements', IEEE Transactions on Electromagnetic Compatibility, vol. 41, no. 4, pp. 440–445, Nov. 1999, doi: 10.1109/15.809846
- [15] S. van de Beek, R. Vogt-Ardatjew, H. Schipper, and F. Leferink, 'Vibrating intrinsic reverberation chambers for shielding effectiveness measurements', in International symposium on electromagnetic compatibility - EMC EUROPE, Sep. 2012, pp. 1–6. doi: 10.1109/EMCEurope.2012.6396655
- [16] A. C. Marvin and J. F. Dawson, 'Efficient Measurement Techniques and Modelling of Printed Circuit Board Shields', in 2022 international symposium on electromagnetic compatibility - EMC EUROPE, 2022, p. 6. Available: <https://eprints.whiterose.ac.uk/186818/>
- [17] P. Radhakrishnan, T. Claeys, J. Catrysse, and D. Pissoot, 'Impact of the Bonding Design Parameters on the Shielding Effectiveness of Board-Level Shields at Microwave frequencies', in 2022 International Symposium on Electromagnetic Compatibility – EMC Europe, Sep. 2022, pp. 53–58. doi: 10.1109/EMCEurope51680.2022.9901088.



John F Dawson (Member, IEEE) received his BSc and DPhil degrees in Electronics from the University of York in 1982 and 1989, respectively. He is currently a Senior Lecturer at the University of York. His research interests include, reverberation chamber techniques, shielding, numerical modelling, EMC for circuits and systems.



Andy C Marvin (Life Fellow, IEEE) took his B.Eng, M.Eng, and PhD degrees at the University of Sheffield between 1969 and 1977. He joined the University of York in 1979 and was promoted to full Professor in 1995. He is co-inventor of the Bilog EMC measurement antenna, widely sold and copied by EMC equipment suppliers. He was appointed as the Technical Director of York EMC Services Ltd in 1995. He retired from both these roles in 2017 and was made Professor Emeritus at the University of York in 2018. Since then he has continued his research in Shielding measurement techniques and in thermal noise effects in reverberation chambers.



Yoeri Ariën was born in 1973. He received the M.S. degrees in electrical engineering from Hogeschool Limburg, Hasselt, Belgium, in 1996. From September 1996 to June 1998, he was an electrical design engineer at the Department of Physics, University of Antwerp. From July 1998 to June 1999, he worked as consultant at EBM Philips Hasselt. From July 1999

to May 2012, he was a Microwave engineer specialized in microwave absorbing materials at Emerson & Cuming Microwave products. From May 2012 to March 2017, he was a scientist specialized in EMI suppressing materials at Laird Technologies. Since 2017 he is Microwave Product and R&D Manager at Schlegel Electronic materials. His current research interests include the electromagnetic modeling and characterization of absorbers and EMI suppressing materials.



Johan Catrysse (Life Senior Member, IEEE) received the M.S. degree in electrical engineering from the University of Ghent, Ghent, Belgium, in 1971, and the Ph.D. degree in electrical engineering from the University of Leeds, U.K., in 2005. He was a Full Professor with the Catholic University College of Bruges-Ostend, Ostend, Belgium, and the Founder of the Flanders Mechatronic Engineering Centre (FMEC). Although officially retired, still he is currently an Associated Professor with KU Leuven Campus Bruges, Belgium. His research interests include electromagnetic compatibility (EMC) and reliability of electronic devices. He received the IEEE “Hall of Fame” Award in 2014 for his research on the characterization of

shielding materials. Prof. Catrysse is a Co-Founder of the EMC Europe Symposia, where he is still a member of the international steering committee.



Davy Pissoort (M09, SM13) was born in 1978. He received the M.S. and Ph.D. degrees in electrical engineering from Ghent University, Ghent, Belgium, in 2001 and 2005, respectively. From October 2005 to October 2006, he was a Postdoctoral Researcher at Ghent University. From November 2006 to July 2009, he was a Research Engineer in the Eesof-EDA Department, Agilent Technologies, Belgium. Since 2009, he is a professor at KU Leuven Bruges Campus, where he is the head of the Mechatronics Group. His current research interests include the development of fast and efficient electromagnetic modeling methods for EMC, SI, and PI, the development of characterization methods for shielding materials and gaskets, EM Resilience, dependability of autonomous systems as well as the analysis and testing of the mechanical and thermal reliability of electronic modules.