



Deposited via The University of Leeds.

White Rose Research Online URL for this paper:

<https://eprints.whiterose.ac.uk/id/eprint/1869/>

---

**Book Section:**

Apel, Th., Berzins, M., Jimack, P.K. et al. (2000) Mesh shape and anisotropic elements : theory and practice. In: Whiteman, J.R., (ed.) The Mathematics of Finite Elements and Applications X : Proceedings of the Tenth Conference on The Mathematics of Finite Elements and Applications (MAFELAP 1999), Middlesex, UK, 22-25 June 1999. Elsevier, Oxford, pp. 367-376. ISBN: 0080435688.

---

**Reuse**

Items deposited in White Rose Research Online are protected by copyright, with all rights reserved unless indicated otherwise. They may be downloaded and/or printed for private study, or other acts as permitted by national copyright laws. The publisher or other rights holders may allow further reproduction and re-use of the full text version. This is indicated by the licence information on the White Rose Research Online record for the item.

**Takedown**

If you consider content in White Rose Research Online to be in breach of UK law, please notify us by emailing [eprints@whiterose.ac.uk](mailto:eprints@whiterose.ac.uk) including the URL of the record and the reason for the withdrawal request.



**White Rose**  
university consortium  
Universities of Leeds, Sheffield & York

## **White Rose Consortium ePrints Repository**

<http://eprints.whiterose.ac.uk/>

This is an author produced version of a chapter published in **The Mathematics of Finite Elements and Applications X : Proceedings of the Tenth Conference on The Mathematics of Finite Elements and Applications (MAFELAP 1999), Middlesex, UK, 22-25 June 1999.**

White Rose Repository URL for this paper:  
<http://eprints.whiterose.ac.uk/1869/>

---

### **Published paper**

Apel, Th., Berzins, M., Jimack, P.K., Kunert, G., Plaks, A., Tsukerman, I. and Walkley, M. (2000) *Mesh shape and anisotropic elements : theory and practice*. In: The Mathematics of Finite Elements and Applications X : Proceedings of the Tenth Conference on The Mathematics of Finite Elements and Applications (MAFELAP 1999), Middlesex, UK, 22-25 June 1999. Elsevier, Oxford, pp. 367-376. ISBN 0080435688

---

# 1 MESH SHAPE AND ANISOTROPIC ELEMENTS: THEORY AND PRACTICE

Th. Apel<sup>a</sup>, M. Berzins<sup>b</sup>, P.K. Jimack<sup>b</sup>, G. Kunert<sup>a</sup>, A. Plaks<sup>c</sup>, I. Tsukerman<sup>c</sup>,  
M. Walkley<sup>b</sup>

<sup>a</sup>Fak. Mathematik, TU Chemnitz, D-09107 Chemnitz, Germany.

<sup>b</sup>CPDE Unit, Computer Studies, Univ. of Leeds, LS2 9JT, UK.

<sup>c</sup>Electrical Eng Dept, The University of Akron, OH 44325-3904, USA.

## ABSTRACT

The relationship between the shape of finite elements in unstructured meshes and the error that results in the numerical solution is of increasing importance as finite elements are used to solve problems with highly anisotropic and, often, very complex solutions. This issue is explored in terms of *a priori* and *a posteriori* error estimates, and through consideration of the practical issues associated with assessing element shape quality and implementing an adaptive finite element solver.

**Key words.** anisotropic finite elements, *a priori* estimates, *a posteriori* estimates, element shape, maximum angle condition

## 1.1 INTRODUCTION

The solutions of many important partial differential equations (PDEs) possess features whose accurate resolution using finite element (FE) trial functions requires local refinement of the underlying computational mesh. Frequently however these solution features are strongly directional, with the principal length scale in one direction being significantly smaller than in others. Examples of such features include boundary layers, shocks and edge singularities. The most efficient FE trial spaces for representing these solutions are defined by the use of anisotropic meshes whose elements have an orientation and geometry which reflect the nature of the solution itself. In this paper we present a brief overview of some of our work towards better understanding the practical issues associated with using such anisotropic meshes. This begins by considering how one might define anisotropic

elements in 2D and 3D and the observation that, in order to realize improved *a priori* estimates using such elements, interpolation error estimates which make explicit use of anisotropy need to be derived. This is discussed in §1.2, which also shows how improved *a priori* estimates may be made for certain model problems when an appropriate sequence of anisotropic meshes is considered. Section 1.3 of the paper then considers *a posteriori* error estimates on anisotropic meshes. It is observed that conventional *a posteriori* estimates are not generally appropriate for anisotropic elements and a number of modified estimators are considered for two different types of PDE.

Having introduced a fundamental theory which is applicable to appropriately aligned anisotropic meshes in §§1.2 and 1.3, the final parts of the paper discuss some of the algorithmic issues associated with mesh shape and anisotropic mesh adaptivity respectively. In §1.4 a practical means of quantifying the quality of the shape of a tetrahedron is introduced and its use in estimating interpolation error is illustrated. This is followed by a brief comparison with some other known element quality indicators. Finally, in §1.5 the adaptive solution of a 3D hyperbolic test problem is considered. It is demonstrated that the use of anisotropic elements can improve the solution process through the addition of a very simple “*r*-refinement” strategy to a conventional isotropic “*h*-refinement” algorithm.

## 1.2 A PRIORI ERROR ESTIMATION

Classical finite element theory assumes that the aspect ratio of the finite elements is bounded. In contrast to this, the aspect ratio of anisotropic finite elements is large, and may even be unbounded in the limit. If we wish to use such elements we must be aware that the whole finite element theory has then to be reassessed. In order to convince ourselves of the necessity of anisotropic mesh refinement consider the following two examples.

**Example 1** Consider the Poisson equation,  $-\Delta u = f$  in  $\Omega$ , with Dirichlet boundary conditions,  $u = g$  on  $\partial\Omega$ , in a polyhedral domain  $\Omega \subset \mathbb{R}^3$ . It is well known that the solution  $u$  has singularities of  $r^\lambda$  type near edges with interior angle  $\omega$ , with  $\lambda = \pi/\omega < 1$  for  $\omega > \pi$ . Since  $r$  is here the distance to the edge and the solution is more regular in the direction of the edge, the solution behaves anisotropically.

As a result of this singularity, the finite element method with piecewise linear shape functions on a quasi-uniform family of tetrahedral meshes converges with order  $h^\lambda$  in the energy norm. To recover the optimal convergence order  $h$ , an anisotropically refined finite element mesh is suggested, see Figure 1.1 for an example mesh in the neighbourhood of an edge. Such meshes have been described, and the optimal convergence order has been proved by Apel *et al.* [1, 2, 5] under different assumptions on the data and also for higher order shape functions. Several refinement strategies are compared in [4].

**Example 2** The solution of the singularly perturbed reaction-diffusion problem  $-\varepsilon^2 \Delta u + cu = f$  in  $\Omega = (0, 1)^2$ ,  $u = 0$  on  $\partial\Omega$ , behaves like  $1 - e^{-r/\varepsilon}$ ,  $r$  being here the distance to  $\partial\Omega$ . Therefore the  $\ell$ th derivative in the normal direction grows with  $\varepsilon^{-\ell}$  in a boundary layer of width  $\mathcal{O}(\varepsilon |\ln \varepsilon|)$ , while derivatives in the tangential direction are not affected by  $\varepsilon \ll 1$ .

Consequently, the finite element method with trial functions of degree  $k$  converges

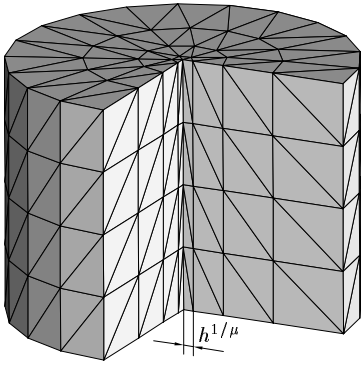

Figure 1.1: Anisotropic mesh near edge.

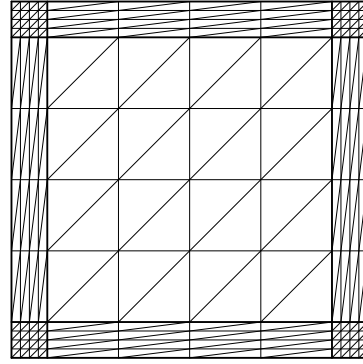

Figure 1.2: Anisotropic mesh in a boundary layer.

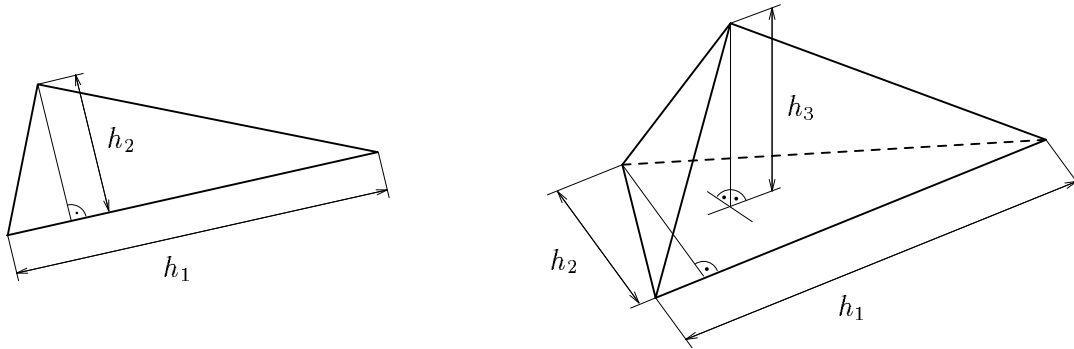

Figure 1.3: Illustration of the definition of the element sizes.

in the energy norm like  $\| \| u - u_h \| \| \leq Ch^k \varepsilon^{1/2-k}$  on a family of quasi-uniform meshes. Anisotropic refinement in the boundary layer, as shown in Figure 1.2, leads to the optimal error estimate  $\| \| u - u_h \| \| \leq Ch^k (\varepsilon^{1/2-\delta} + h)$  [1, 3],  $\delta > 0$  arbitrarily small. We note that the number of unknowns is of the order  $h^{-d}$ ,  $d$  being the space dimension, in both examples. Moreover, an optimal error estimate that is uniform in the perturbation parameter  $\varepsilon$ , cannot be obtained with isotropic mesh refinement.

One of the basic tasks in finite element theory is to estimate the local interpolation error. Such error estimates are needed for *a priori* estimates of the finite element error, for the theory of error estimators, and in the multilevel theory for the solution of the resulting systems of equations. For simplicity, let us focus here on Lagrange interpolation with linear trial functions on simplicial elements as one of the simplest interpolation operators, though this operator is not suited for interpolating functions with low regularity.

Classical finite element theory leads to the estimate

$$|u - I_h u|_{1,p,K} \leq Cah |u|_{2,p,K},$$

where we denote by  $a$  the aspect ratio of the element  $K$  and by  $|\cdot|_{m,p,K}$  the usual seminorm in  $W^{m,p}(K)$ . The dependence on the aspect ratio was removed in the fifties ([17]) and seventies ([6, 10]), but the resulting error estimate was still not satisfactory because only the diameter  $h$  of the element appears in the estimate.

In order to compensate large norms of certain directional derivatives of the solution  $u$  by a small element size in this direction, we need sharper estimates, like

$$|u - I_h u|_{1,p,K} \leq C \sum_{i=1}^d h_i \left| \frac{\partial u}{\partial x_i} \right|_{1,p,K}, \quad (1.1)$$

where  $h_i$  are suitably defined element sizes (see Figure 1.3 for a possible definition). We emphasize that a refined estimate on the reference element is necessary for the proof of such estimates, see [1, Example 2.1]. Moreover, the geometry of the elements is restricted by a maximal angle condition (see also §1.4 below). Anisotropic local interpolation error estimates may now be derived. Indeed, such estimates have been proved by Apel *et al.* for several element types (triangles, quadrilaterals, tetrahedra, triangular prisms, hexahedra, including some subparametric and non-conforming elements), for trial functions of arbitrary order, and under various smoothness assumptions on the function to be interpolated (including functions from weighted Sobolev spaces) [1, 2].

We stress that anisotropic elements must be treated carefully. For example, estimate (1.1) is valid for simplicial elements and linear trial functions under the following assumptions on  $p$ . In the 2D case (1.1) is valid for the whole range of  $p$ ,  $p \in [1, \infty]$ . However, in the 3D case the estimate is valid for  $p \in (3/2, \infty]$  for isotropic elements but only for  $p \in (2, \infty]$  for anisotropic elements. There is a counterexample for  $p \leq 2$ , see [2]. For the interpolation of less regular functions one can use modified Scott–Zhang interpolants [1].

### 1.3 A POSTERIORI ERROR ESTIMATION

The fundamental requirements of an adaptive algorithm that is able to exploit the use of anisotropic elements are that information on the *stretching direction* of the anisotropic elements, the *stretching ratio* (or *aspect ratio*) of the elements and the *size* of the elements should be utilized. None of these issues have yet been fully understood however. For example, the stretching direction and ratio are often determined (heuristically) by investigation of the Hessian matrix, but other approaches may equally well be employed (see § 1.5 for example). The question of the appropriate element size is closely related to *a posteriori error estimation*.

Research into error estimators for anisotropic meshes has been intensified in recent years. So far, many applications of anisotropic elements utilize heuristic arguments and lack rigorously analyzed error estimators. Some strictly mathematically-based estimators have appeared recently however, due to Siebert [16], Kunert [13, 14], Kunert and Verfürth [15] and Dobrowolski *et al.* [9]. Before discussing these estimators in more detail, let us comment on an important feature that seems to be inherent in anisotropic error estimators. The theory of these estimators is not as complete as for isotropic elements since, at this time, no error estimator is known that bounds the error reliably from *above and below*, independently of the mesh  $\mathcal{T}_h$  and the solutions  $u$  and  $u_h$ . In other words, the effectivity index cannot be guaranteed to be  $\mathcal{O}(1)$ . This rather unsatisfactory situation can be interpreted in two ways.

- If the error is to be bounded from above and below *without further assumptions* on  $u, u_h, \mathcal{T}_h$ , then the two error bounds have to contain different terms. Hence *two*

error estimators would be required, one for each bound.

- If a *single error estimator* is to give upper and lower error bounds, then the mesh  $\mathcal{T}_h$  and the solutions  $u, u_h$  have to correspond in some way. For example, the anisotropy of  $\mathcal{T}_h$  may have to be aligned with the anisotropy of  $u$  to result in an effectivity index  $\mathcal{O}(1)$ . Such assumptions on  $u, u_h, \mathcal{T}_h$  can be seen in the aforementioned work, and are briefly discussed below.

In the following paragraphs we briefly describe existing approaches to anisotropic *a posteriori* error estimation. Rather than giving detailed formulae we attempt to present the main ideas and results for each of the estimators. We begin by investigating the Poisson problem (see e.g. Example 1 of the previous section).

Siebert [16] considers anisotropic *rectangular, cuboidal or prismatic* meshes and derives a *residual error estimator* by measuring and weighting the residuals (i.e. gradient jumps and element residual). Two specific assumptions on  $u, u_h, \mathcal{T}_h$  guarantee a global upper and a local lower error bound in the energy norm.

In Kunert [14], a *residual error estimator* for *tetrahedral or triangular* meshes is presented, thus giving a greater geometrical flexibility. Moreover, it improves Siebert's estimator by means of better weights of the gradient jumps. Hence one of Siebert's assumptions is superfluous. The remaining assumption on  $u, u_h, \mathcal{T}_h$  is expressed by a so-called *matching function*  $m_1(v, \mathcal{T}_h)$  which measures how well an anisotropic mesh  $\mathcal{T}_h$  is aligned with an anisotropic function  $v$  (see [13] for details). The matching function  $m_1(u - u_h, \mathcal{T}_h)$  enters the upper bound of the error: the better the mesh  $\mathcal{T}_h$  is suited to the problem, the sharper the error bound will be. Note that although  $m_1(u - u_h, \mathcal{T}_h)$  cannot be calculated exactly, it can be approximated numerically ([13]). In Kunert and Verfürth [15] a modification of the previous *residual error estimator* is analyzed. The difference being that the gradient jumps alone suffice to define the estimator, i.e. the element residuals are omitted. All conclusions and results remain valid. Kunert has also derived a recent *error estimator* based on the solution of a *local problem* which is given for tetrahedral meshes. The appropriate choice of local problem appears to be more critical than for the isotropic case, leading to a result very similar to that obtained for the residual error estimation.

Zienkiewicz–Zhu (ZZ) type error estimators utilize a postprocessing procedure (like an averaged gradient) to estimate the error. On anisotropic meshes, such estimators are much less developed. Furthermore, on these meshes the analysis is hindered by an apparent lack of superconvergence. Nevertheless some initial promising attempts of ZZ estimators are presented in Kunert [13]. There, the equivalence to the residual error estimator of [15] is proven for specific meshes. Also in [13], Kunert derives and analyzes an  $L_2$  *residual error estimator* for tetrahedral meshes that bounds the error (in the  $L_2$  norm) from above and below. Additionally, the face residuals (i.e. the gradient jumps) alone suffice to define this estimator, see Kunert and Verfürth [15] for further details.

Dobrowolski *et al.* [9] also investigate the Poisson problem on *triangular* meshes. Applying the methodology of Bank and Weiser, they derive a *global error estimator* by solving a *global* problem. The (global) error bound relies on a saturation assumption that again requires a suitable anisotropic mesh. Note that no *local* error bound is obtained.

We summarize by noting that recent and ongoing research is ensuring that anisotropic *a posteriori* error estimators are becoming increasingly well understood. As well as for

Poisson's equation discussed here it should also be noted that other problems are also currently under investigation. These include singularly perturbed reaction–(convection)–diffusion problems which lend themselves naturally to anisotropic boundary or interior layers. A model equation  $-\varepsilon\Delta u + u = f$  is investigated by Kunert [13, 15] on tetrahedral meshes (see also Example 2 of the previous section). A *residual error estimator* is derived that bounds the error (in the  $\varepsilon$  dependent energy norm) locally from below and globally from above. Note that the upper error bound contains exactly the same matching function  $m_1(u - u_h, \mathcal{T}_h)$  as in the Poisson case. Despite this recent progress however it is clear that the incorporation of these, and possible future estimators, into practical adaptive anisotropic strategies is still a significant challenge. Some of the issues associated with this challenge are discussed in the remainder of this paper.

## 1.4 INTERPOLATION ERRORS AND ELEMENT SHAPE

Nedelec-Raviart-Thomas edge and face elements play an increasingly important role in computational electromagnetism, incompressible flow problems, and other areas. This section presents, as a somewhat unexpected application of edge elements, a new  $H^1$ -interpolation error bound for first order tetrahedra. This estimate is in terms of the minimum singular value of a particular rectangular matrix. The derivation (see [19]) is based on the well known fact ([8]) that the standard Lagrange  $P^1$ -interpolation (with operator  $\Pi_{P^1}$ ) of a scalar field  $u$  on a tetrahedral mesh  $M$  is equivalent to the edge element interpolation  $\Pi_{edge}$  of the respective conservative field  $v = \nabla u$ . ( $\Pi_{edge}$  preserves edge circulations, so that  $\int_{edge} (\Pi_{edge} v) \cdot dl = \int_{edge} v \cdot dl$  over each tetrahedral edge.)

### 1.4.1 The Minimum Singular Value Condition for Tetrahedra

The shape of a tetrahedron can be characterized by six unit vectors  $e_1, \dots, e_6$  directed along the edges (in either of two possible directions). The element '**edge shape matrix**'  $E$  [19] is a  $3 \times 6$  matrix whose columns are the (Cartesian) vectors  $e_i$ . The  $E^T$ -matrix governs the transformation between the Cartesian and edge components of an arbitrary vector  $\xi$  in  $R^3$ :  $\xi_{edge} = E^T \xi_{cart}$ , where  $\xi_{edge} \in R^6$  and  $\xi_{cart} \in R^3$ .

A key role in our analysis is played by the singular value decomposition  $E = P\Sigma Q^T$  of the edge shape matrix. In particular, the *minimum singular value*<sup>1</sup>  $\sigma_{\min}(E) = \lambda_{\min}^{1/2}(EE^T)$  characterizes, algebraically, the level of linear independence of the unit edge vectors  $e_i$ , or, geometrically, their proximity to one plane. More precisely ([19]),

$$\sigma_{\min}(E) = \min_{\|\xi_{cart}\|=1} \|\xi_{edge}\|_{R^6} = \min_{\|\xi_{cart}\|=1} \|E^T \xi_{cart}\|_{R^6}, \quad (1.2)$$

with minimization achieved when  $\xi_{cart}$  is the eigenvector  $\xi_{\min}$  corresponding to  $\lambda_{\min}(EE^T)$ . Note that  $\sigma_{\min}(E) = 0$  if and only if all six edge vectors lie in one plane (perpendicular to  $\xi_{\min}$ ), i.e. the tetrahedron is degenerate. Moreover, the following error bound ([19]) shows that  $\sigma_{\min}(E)$  may be considered as a governing factor for interpolation errors:

$$\|\Pi_{P^1} u - u\|_{H^1(\Omega)}^2 = \|\Pi_{edge} v - v\|_{(L_2(\Omega))^3}^2 \leq C(v) \cdot \sum_{K_i \in M} h_i^2 (\sigma_{\min}^{-2}(E(K_i)) V_i). \quad (1.3)$$

---

<sup>1</sup>Which is obviously independent of the choice of the Cartesian system in  $R^3$ .

Here  $v = \nabla u$  is a (sufficiently smooth) conservative field,  $K_i$  is a tetrahedral element,  $h_i = \text{diam}(K_i)$ ,  $V_i = \text{meas}(K_i)$ . This is a global estimate, but each term in the sum represents the square of the element-wise interpolation error.

### 1.4.2 Links with Maximum Angle, Křížek and Jamet Conditions

In the illustrative case of a triangular element with angles  $\phi_1, \phi_2, \phi_3$  the minimum singular value of the  $2 \times 3$  edge shape matrix

$$E = \begin{bmatrix} 1 & \cos \phi_1 & -\cos \phi_2 \\ 0 & \sin \phi_1 & \sin \phi_2 \end{bmatrix} \quad (1.4)$$

can be explicitly evaluated via the trace of  $(EE^T)^{-1}$ , which ultimately yields

$$\frac{1}{3}(\sin^2 \phi_1 + \sin^2 \phi_2 + \sin^2 \phi_3) \leq \sigma_{\min}^2(E) \leq \frac{2}{3}(\sin^2 \phi_1 + \sin^2 \phi_2 + \sin^2 \phi_3). \quad (1.5)$$

This is equivalent to the maximum angle condition [17, 6] as, in (1.5),  $\sigma_{\min}$  may only tend to zero on a sequence of elements if one angle tends to  $\pi$  and the other two to zero.

Possibly the most common geometric characteristic of a *tetrahedral* element is the ratio of radius  $r$  of the inscribed sphere to the maximum element edge length  $h$ . Tsukerman [19] shows that the singular value criterion is less stringent than the  $r/h$  ratio.

Křížek [12] introduced a sufficient convergence condition requiring that all dihedral angles, as well as all face angles, be bounded away from  $\pi$ . A rather simple lower bound of  $\sigma_{\min}$  in terms of the dihedral and face angles can be given and will be presented elsewhere. The minimum singular value and Křížek conditions are equivalent as asymptotic criteria of convergence of piecewise-linear interpolation on a family of tetrahedral meshes.

Jamet [10] has obtained interpolation error bounds under quite general assumptions. For tetrahedral elements, the governing factor  $\cos \theta$  in Jamet's estimate can be obtained from the rightmost expression in (1.2) for  $\sigma_{\min}$  by simply replacing the 2-norm in  $R^6$  with the  $\infty$ -norm.

## 1.5 A CASE STUDY OF 3D ANISOTROPIC REFINEMENT

We conclude this paper with a simple example which demonstrates the practical use of anisotropic adaptation using an *hr*-refinement scheme in which the nodes are moved according to an edge-based error indicator and comparing against standard *h*-refinement results. The test problem considered is the steady 3D hyperbolic equation  $\mathbf{a} \cdot \nabla u = 0$ , and a standard SUPG finite element method [11] is used, based on an unstructured tetrahedral mesh with linear basis functions  $\phi_i(\mathbf{x})$  and test functions  $\psi_i(\mathbf{x})\phi_i + \tau \mathbf{a} \cdot \nabla \phi_i$  defined at each of the  $N_P$  nodes  $\mathbf{x}_i$ . The parameter  $\tau$  is defined as an element quantity,  $\tau^K = \alpha h^K / |\mathbf{a}|$  for some measure of the element length  $h^K$ , taken here to be the minimum element height, and the resulting linear system is solved using the ILU preconditioned GMRES method.

In order to compare the two adaptive algorithms being considered, standard finite element ***h*-refinement** is driven by solving a problem with a known solution and using the  $L^1$  norm of the *exact* error  $e(\mathbf{x})$  on each element. The total  $L^1$  error,  $e$ , may then be split into its contributions  $e^K$  from each of the  $N_E$  elements. To achieve a final  $L^1$  error

of  $\epsilon^*$  the error in each cell is reduced to below  $\epsilon^*/N_E$  using nested isotropic  $h$ -refinement of an initial unstructured tetrahedral base mesh.

As well as using local mesh refinement, the **hr-refinement** algorithm makes use of a simple node movement scheme designed to steer nodes towards regions of sharp variation in the solution. This is motivated by recent work of Berzins, [7], in which the interpolation error is estimated by assuming that the exact solution can be approximated in a locally quadratic form on each tetrahedral element and then considering the difference between this quadratic function and the linear finite element interpolant:

$$\int_K e_{lin}^2 d\Omega = \frac{6}{4} V^K \frac{2}{7!} \left( \left( \sum_{s=1}^6 d_s \right)^2 - d_1 d_4 - d_2 d_5 - d_3 d_6 + \sum_{s=1}^6 d_s^2 \right) \quad (1.6)$$

where  $V^K$  is the volume of element  $K$ . Here,  $d_s$  denotes the directed edge second derivative for an edge  $s = s(\mathbf{x}_i, \mathbf{x}_j)$  that connects the nodes  $\mathbf{x}_i$  and  $\mathbf{x}_j$ . It is given by

$$d_s := \left( \nabla u(\mathbf{x}_i) - \nabla u(\mathbf{x}_j) \right) \cdot (\mathbf{x}_i - \mathbf{x}_j) \cdot L_{ij}^{-2} \quad \text{with} \quad L_{ij} := \|\mathbf{x}_i - \mathbf{x}_j\|. \quad (1.7)$$

A node movement scheme is then developed by using the edge second derivatives (1.7) as weights in the following weighted average expression for the node position,

$$\mathbf{x}_i^{av} = \frac{\sum_j L_{ij} |d_s| \mathbf{x}_j}{\sum_j L_{ij} |d_s|} \quad \text{with} \quad s = s(\mathbf{x}_i, \mathbf{x}_j). \quad (1.8)$$

The nodal position is updated by  $\mathbf{x}_i \rightarrow (1 - \gamma_i)\mathbf{x}_i + \gamma_i \mathbf{x}_i^{av}$  where  $\gamma_i$  is a safety factor at each node  $\mathbf{x}_i$  that prevents the mesh from becoming tangled. Several such iterations are performed at each  $r$ -refinement stage (which is undertaken prior to  $h$ -refinement).

Further details of the test problem are shown in Figure 1.4 (a 2D form of the problem is also included to aid comprehension). At the inflow boundary, where  $\mathbf{a} \cdot \mathbf{n} < 0$ , the imposed solution is defined to have a thin vertical layer across which  $u$  varies linearly from 1 to 0. The solution within the domain is therefore defined by the convection of this layer in the direction  $\mathbf{a}$ , as illustrated. Here,  $\mathbf{a} = (2, 1, 1)$  and the layer has thickness 0.025 on a unit cube domain.

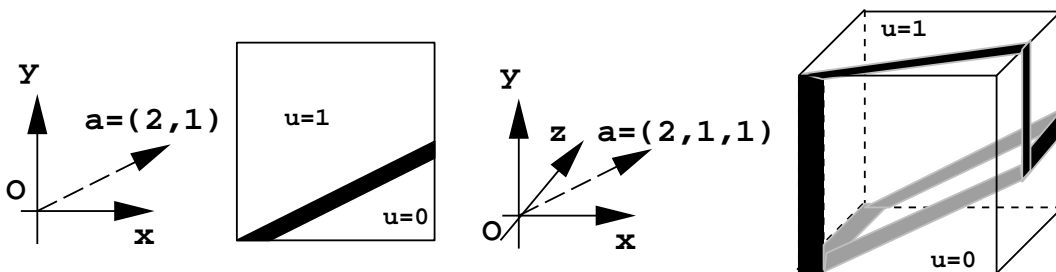

Figure 1.4: Model steady solution of the 3D convection equation

The initial mesh is a uniform  $11^3$  discretisation of the unit cube, with each sub-cube divided into six similar tetrahedra. Figure 1.5 compares the total error for the  $h$ - and  $hr$ -refinement schemes. The  $hr$ -refinement scheme significantly reduces the error on a given

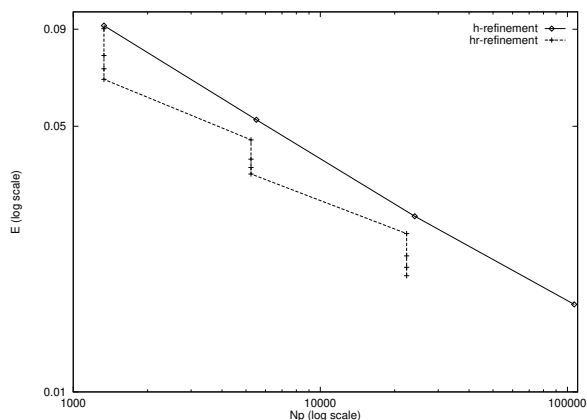

Figure 1.5: Errors on the adapted grid sequences for  $h$ - and  $hr$ -refinement

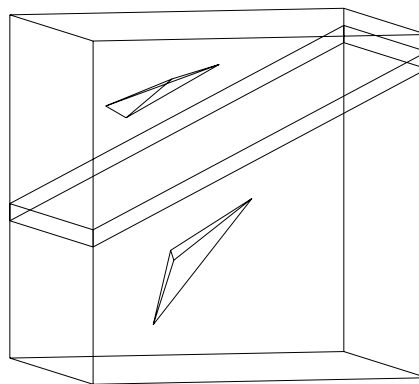

Figure 1.6: Zoom of the  $hr$ -refined tetrahedra near the layer

grid, leading a similar level of error with approximately 20000 nodes to that requiring over 100000 nodes using isotropic  $h$ -refinement. Figure 1.6 shows two tetrahedra from the final  $hr$ -refined mesh in the region  $(x, y, z) \in [0.3, 0.4] \times [0.7, 0.8] \times [0.1, 0.2]$ . It is seen that the upper tetrahedron is aligned with the layer, although large internal angles have been produced. In contrast, the lower tetrahedron is less well-aligned.

## 1.6 DISCUSSION

This paper reflects the main topics presented at the Minisymposium on Anisotropic Finite Elements at the 1999 MAFELAP conference. Whilst it is impossible to cover all aspects relating to element shape and anisotropy in such a brief exposition, we have attempted to present an overview of what we believe to be some of the most important issues: *a priori* and *a posteriori* error estimation, mesh quality, and mesh adaptivity.

## ACKNOWLEDGEMENTS

Collaboration between the groups at Chemnitz and Leeds has been supported by the DAAD and British Council under the ARC programme. The work of TA and GK (§§2 and 3) was partially supported by the DFG (SFB 393). The work of IT and AP (§4) was supported in part by the NSF. The work of MW (§5) was supported by the EPSRC.

## REFERENCES

- [1] Th. Apel (1999). *Anisotropic finite elements: Local estimates and applications*. Advances in Numerical Mathematics. Teubner, Stuttgart.
- [2] Th. Apel and M. Dobrowolski (1992). Anisotropic interpolation with applications to the finite element method. *Computing*, 47:277–193.

- [3] Th. Apel and G. Lube (1998). Anisotropic mesh refinement for a singularly perturbed reaction diffusion model problem. *Appl. Numer. Math.*, 26:415–433.
- [4] Th. Apel and F. Milde (1996). Comparison of several mesh refinement strategies near edges. *Comm. Numer. Methods Engrg.*, 12:373–381.
- [5] Th. Apel and S. Nicaise (1998). The finite element method with anisotropic mesh grading for elliptic problems in domains with corners and edges. *Math. Methods Appl. Sci.*, 21:519–549.
- [6] I. Babuška and A.K. Aziz (1976). On the angle condition in the finite element method. *SIAM J. Numer. Anal.*, 13:214–126.
- [7] M. Berzins (1998). A solution-based triangular and tetrahedral mesh quality indicator. *SIAM J. Sci. Comp.*, 19:2051–1060.
- [8] A. Bossavit (1988). A rationale for 'edge elements' in 3-D fields computations. *IEEE Trans. Magn.*, 24:74–79.
- [9] M. Dobrowolski, S. Gräf and C. Pflaum (1999). On a posteriori error estimators in the finite element method on anisotropic meshes. *Elec. Trans. Numer. Anal.*, 8:36–45.
- [10] P. Jamet (1976). Estimations de l'erreur pour des éléments finis droits presque dégénérés. *Rairo Anal. Numer.*, 10:43–60.
- [11] C. Johnson (1987). *Numerical solution of partial differential equations by the finite element method*. Cambridge University Press.
- [12] M. Křížek (1992). On the maximum angle condition for linear tetrahedral elements. *SIAM J. Numer. Anal.*, 29:513–520.
- [13] G. Kunert (1999). *A posteriori error estimation for anisotropic tetrahedral and triangular finite element meshes*. Ph.D. Thesis, TU Chemnitz (<http://www.tu-chemnitz.de/pub/1999/0012/index.html>).
- [14] G. Kunert (1999). An a posteriori residual error estimator for the finite element method on anisotropic tetrahedral meshes. To appear in *Numer. Math.*
- [15] G. Kunert and R. Verfürth (1999). Edge residuals dominate a posteriori error estimates for linear finite element methods on anisotropic triangular and tetrahedral meshes. To appear in *Numer. Math.*
- [16] K.G. Siebert (1996). An a posteriori error estimator for anisotropic refinement. *Numer. Math.*, 73:373–398.
- [17] J.L. Synge (1957). *The hypercircle in mathematical physics; a method for the approximate solution of boundary value problems*. Cambridge University Press.
- [18] I.A. Tsukerman (1998). A general accuracy criterion for finite element approximation. *IEEE Trans. Magn.*, 34:2425–1428.
- [19] I.A. Tsukerman (1998). Approximation of conservative fields and the element 'edge shape matrix'. *IEEE Trans. Magn.*, 34:3248–3251.