



This is a repository copy of *Downstream of the HOX genes: explaining conflicting tumour suppressor and oncogenic functions in cancer*.

White Rose Research Online URL for this paper:

<https://eprints.whiterose.ac.uk/184002/>

Version: Published Version

Article:

Morgan, R., Hunter, K. orcid.org/0000-0002-7873-0877 and Pandha, H.S. (2022) Downstream of the HOX genes: explaining conflicting tumour suppressor and oncogenic functions in cancer. *International Journal of Cancer*, 150 (12). pp. 1919-1932. ISSN 0020-7136

<https://doi.org/10.1002/ijc.33949>

Reuse

This article is distributed under the terms of the Creative Commons Attribution (CC BY) licence. This licence allows you to distribute, remix, tweak, and build upon the work, even commercially, as long as you credit the authors for the original work. More information and the full terms of the licence here:

<https://creativecommons.org/licenses/>

Takedown

If you consider content in White Rose Research Online to be in breach of UK law, please notify us by emailing eprints@whiterose.ac.uk including the URL of the record and the reason for the withdrawal request.



eprints@whiterose.ac.uk
<https://eprints.whiterose.ac.uk/>

REVIEW

Downstream of the HOX genes: Explaining conflicting tumour suppressor and oncogenic functions in cancer

Richard Morgan¹  | Keith Hunter² | Hardev S. Pandha³

¹School of Biomedical Sciences, University of West London, London, UK

²Unit of Oral and Maxillofacial Pathology, School of Clinical Dentistry, University of Sheffield, Sheffield, UK

³Faculty of Health and Medical Sciences, University of Surrey, Guildford, UK

Correspondence

Richard Morgan, School of Biomedical Sciences, University of West London, London W5 5RF, UK.

Email: richard.morgan@uwl.ac.uk

Abstract

The HOX genes are a highly conserved group of transcription factors that have key roles in early development, but which are also highly expressed in most cancers. Many studies have found strong associative relationships between the expression of individual HOX genes in tumours and clinical parameters including survival. For the majority of HOX genes, high tumour expression levels seem to be associated with a worse outcome for patients, and in some cases, this has been shown to result from the activation of pro-oncogenic genes and pathways. However, there are also many studies that indicate a tumour suppressor role for some HOX genes, sometimes with conclusions that contradict earlier work. In this review, we have attempted to clarify the role of HOX genes in cancer by focusing on their downstream targets as identified in studies that provide experimental evidence for their activation or repression. On this basis, the majority of HOX genes would appear to have a pro-oncogenic function, with the notable exception of HOXD10, which acts exclusively as a tumour suppressor. HOX proteins regulate a wide range of target genes involved in metastasis, cell death, proliferation and angiogenesis, and activate key cell signalling pathways. Furthermore, for some functionally related targets, this regulation is achieved by a relatively small subgroup of HOX genes.

KEYWORDS

HOX, oncogene, PBX, tumour suppressor

1 | INTRODUCTION

The HOX genes are a family of transcription factors first characterised for their role in the early development of insects, and subsequently

found to have close homologues in vertebrates with strikingly conserved functions, including the determination of cell and tissue identity.^{1,2} In *Drosophila*, there is a single chromosomal cluster of HOX genes, the members of which are expressed along the anterior to

Abbreviations: DAPK1, death-associated protein kinase 1; EGFR, epidermal growth factor receptor; EMT, epithelial to mesenchymal transition; ER, oestrogen receptor; HNSCC, head and neck squamous cell carcinoma; IGFBP-3, insulin-like growth factor binding protein-3; ITGA2, gene encoding integrin A2; I κ B α , inhibitor of NF- κ B alpha; lncRNA, long noncoding RNA; MEIS, myeloid ecotropic viral integration site 1 homolog; MMP, matrix metalloproteinase; NEP, neutral endopeptidase; PBX, pre-B-cell leukaemia homeobox; PDEF, prostate-derived Ets factor; PD-L2, programmed death protein ligand 2; PDPK1, 3-phosphoinositide-dependent protein kinase 1; RTK, receptor tyrosine kinase; SAMD9, sterile alpha motif domain-containing protein 9; TDO2, tryptophan 2,3-dioxygenase; VASP, vasodilator-stimulated phosphoprotein; VEGF, vascular endothelial growth factor; VEGFR, vascular endothelial growth factor receptor.

This is an open access article under the terms of the Creative Commons Attribution License, which permits use, distribution and reproduction in any medium, provided the original work is properly cited.

© 2022 The Authors. *International Journal of Cancer* published by John Wiley & Sons Ltd on behalf of UICC.

posterior embryonic axis in the same order, both spatially and temporally, as they are in the cluster, with the most 3' member expressed first and most anteriorly. This cluster has been duplicated twice in the course of evolution, such that mammals have four clusters, the members of which are also expressed in the same order along the anterior to posterior axis, with the 3' member expressed first, reflecting a closely conserved regulation of HOX genes between invertebrates and vertebrates.³

In humans, the four clusters of HOX genes are named A, B, C and D, and are located on chromosomes 7, 17, 12 and 2, respectively. The individual genes within each cluster are numbered consecutively from the 3' end, so, for example, the first gene in the HOXB complex is named HOXB1. The genes in the equivalent position in each of the other complexes are paralogous, having descended from the same ancestral HOX genes, thus HOXA4, HOXC4 and HOXD4 are paralogous of HOXB4. In general, proteins encoded by genes within the same paralogue group have similar sequences, and often have similar functions,^{2,3} although a notable exception, HOXC10 and HOXD10, is described later in this review. A number of HOX genes have been lost during evolution, meaning that in total the four HOX clusters contain 39 genes.³ In mammals, HOX genes are expressed in overlapping patterns along the main anterior to posterior axis during development, with for example HOXB1 expressed in the developing hindbrain and HOXB9 in the posterior half of the spinal cord. Likewise, similar nested sequences of expression occur in other structures, including the limbs and many of the organs.¹⁻³

HOX transcription factors contain a highly conserved DNA binding domain, the homeodomain that facilitates binding to a 4-base pair sequence. Increased binding affinity and specificity is conferred by various co-factors which are themselves transcription factors, including members of the pre-B-cell leukaemia homeobox (PBX) and myeloid ecotropic viral integration site 1 homolog (MEIS) families.⁴ This facilitates both activation and repression of gene transcription in a context-dependent manner. In addition, HOX proteins have roles in the cytoplasm, although these are less well studied. A notable example is the binding of HOXA10 to p38 MAPK leading to its dephosphorylation and hence attenuation of p38 MAPK/STAT3 signalling.⁵ Thus, the cellular location of HOX proteins is important in determining their function, and is in turn influenced by posttranslational modifications that regulate cofactor binding.⁶ For example, acetylation of a lysine residue in HOXB9 (AcK27-HOXB9) causes it to become localised to the cytoplasm, preventing it from transcriptionally regulating its target genes.⁷

In addition to their role in development, it is now well established that HOX genes are strongly expressed in most types of cancer, including prostate,⁸ breast,⁹ lung,¹⁰ renal,¹¹ head and neck¹² and ovarian¹³ cancer, as well as mesothelioma.¹⁴ Although the expression of certain HOX genes is often reported as being characteristic of specific cancers, for example, HOXC4 and HOXC6 in prostate cancer,⁸ generally the majority of the 39 HOX genes are significantly upregulated. There have been numerous studies on the role of HOX genes in cancer, which can be divided broadly into associative studies (establishing a statistically significant relationship between HOX gene expression and key clinical parameters such as disease-free survival), and

mechanistic studies, in which for example the downstream target genes of HOX proteins are identified with experimental evidence for a role in cancer development or progression, using molecular and cell biology approaches such as gene knock out, reduction of expression using short interfering RNAs, or gain of function experiments through the forced expression of a HOX gene. There are many more associative studies than mechanistic ones, although many mechanistic studies also include associative data.

To date, the overall picture that emerges from these studies is rather ambiguous—while some indicate that a particular HOX gene has a tumour suppressor function, others have ascribed it a pro-oncogenic function in the same cancer. In this review, we have focused on mechanistic studies in which molecular and cellular evidence is provided to support a tumour suppressor vs oncogenic function for different HOX genes. On this basis, the majority of HOX genes actually have a pro-oncogenic function. Our analysis reveals that the HOX genes activate (or more rarely repress) a wide range of genes involved in metastasis, cell death, proliferation and angiogenesis, and also activate key cell signalling pathways. While some of these functionally distinct groups of target genes are regulated by many members of the HOX family, others are activated by just a few paralogue groups. HOX genes reported to have both tumour suppressor and pro-oncogenic activities might be context-dependent with respect to cancer type and background gene expression.

2 | ONCOGENIC vs TUMOUR SUPPRESSOR FUNCTIONS OF HOX GENES

It is now clear from the growing body of work across multiple cancer types that while the majority of HOX genes seem to be associated with oncogenesis, a significant minority instead have tumour suppressor functions. This has made it more difficult to come to a global understanding of HOX function in cancer, as for example, some HOX genes are reported to have oncogenic functions in around half of the published studies, but tumour suppressor functions in other studies. Excluding studies that are based only on associative studies (eg, the expression levels of a HOX gene compared to overall survival), and focusing instead on mechanistic studies where the function of the HOX gene in cancer is directly addressed, may help provide a clearer view (Table 1). First, based on mechanistic studies, it becomes apparent that the majority of HOX genes have an oncogenic function. Most HOX genes, including HOXB7,¹⁵⁻⁴⁷ HOXB8⁴⁸⁻⁵⁴ and HOXC10⁵⁵⁻⁷² are only reported to have oncogenic functions, while only two, HOXA5⁷³⁻⁸³ and HOXB13,⁸⁴⁻¹⁰⁸ are notable for having oncogenic functions reported in around 50% of publications, and tumour suppressor functions in the other 50%. Only one HOX gene, HOXD10, seems to act almost exclusively as a tumour suppressor, albeit with a notable exception in head and neck squamous cell carcinoma (HNSCC).¹⁰⁹⁻¹²¹

How can apparently conflicting functions of genes such as HOXA5 and HOXB13 be explained? For the former, oncogenic vs

TABLE 1 HOX genes as tumour suppressors or oncogenes in different cancers

Cancer	Tumour suppressor function	Oncogenic function
Ovarian	A4	A10, A13, B4 (Akt/PI3K upregulated), B9 (increased expression of EMT markers such as vimentin, MMP9 and Oct4), B13 (HOXB13 collaborates with activated ras/direct binding to the Slug promoter), C10 (promotes EMT via increased Slug expression)
Hepatic cellular carcinoma	D10 (represses ERK signalling)	A5, C4 (activates Snail and TGF- β signalling), C10 (upregulates metastasis-related genes, including PDPK1 and VASP), D3 (HOXD3 binds to promoter region of ITGA2 and up-regulates its expression, thus activating ERK1/2 signalling), D3 (HOXD3 can directly target the promoter region of VEGFR and increase VEGFR expression), D9 (HOXD9 can interact with the promoter region of ZEB1 and promotes ZEB1 expression—increased EMT)
Glioblastoma	A11, D10	A5, A9, B8 (activation of the PI3K/AKT pathway and expression of EMT-related genes, possibly through direct binding to the promoter of SAMD9), B13 (direct transcriptional upregulation of lncRNA HOXC-AS3), C6 (increases the phosphorylation of Jun amino-terminal kinase, ERK and P38, as well as the expression of MAPK signalling-related genes, including c-myc, c-jun and p53), C9 (suppresses Beclin1-mediated autophagy by directly inhibiting the transcription of DAPK1), C10 (increases PI3K/AKT signalling)
Oesophageal	D10 (suppresses the activation of the PI3K/AKT/mTOR signalling pathway)	A5 (wnt/ β cat), A13, B2 (activates NANOG and cMYC transcription), B5, B7, B13 (increased NF- κ B/p65 signalling), C6, C13 (direct repression of caspase 3)
Lung		A5, B2, B5 (increased wnt/ β -catenin signalling), B7 (TGF- β /SMAD3, VEGFA, MMP2), B9 (increased MMP9 expression and wnt/ β -catenin signalling), B13 (increased ABCG1, EZH2 and Slug expression), C8 (upregulation of TGF- β 1, downregulation of E-cadherin), C10 (enhanced phosphorylation of PI3K, increased expression of MMP2/9, VCAM-1, vimentin and E-cadherin; increased BET/MEK signalling), C13 (increased cyclin D1 and cyclin E1 expression—entry into G1), D3 (E-cadherin expression lost and plakoglobin strongly repressed, integrin alpha3 and beta3 up-regulated and N-cadherin and integrin alpha4 newly expressed)
Colorectal	A5 (inhibits wnt/ β -catenin signalling), D10 (inhibits AKT/MAPK signalling)	A6, B5 (elevated CXCR4 and integrin beta expression), B7 (increased DNA repair factor KU70/80 expression), B8 (increased wnt/ β -catenin signalling, increased expression of MMP2, c-Myc, CyclinD1, vimentin; STAT3, Vimentin, N-cadherin, Twist, Zeb1 and Zeb2, downregulation of E-cadherin), B9 (increased angptl2, CXCL1, IL8 and TGF- β 1 expression), B13 (increased NF- κ B/p65 signalling), C4, D3 (increased integrin β 3 expression and MAPK/AKT signalling)
Breast	A5 (increased p53 and caspase 2 and 8 expression), A9, B4 (direct binding to StAR-related lipid transfer domain protein 13), D10 (reduced Akt signalling)	A7 (increased ER α expression), B3, B5 (increased EGFR signalling), B7 (increased EGFR signalling, direct protein binding to ER α to increase HER2 expression; increased TGF- β expression; direct binding and activation of EGFR promoter; loss of epithelial proteins, claudin 1 and claudin 7, mislocalization of claudin 4 and E-cadherin and the expression of mesenchymal proteins vimentin and alpha-smooth muscle actin), B9 (increased PI3K/AKT signalling; increased E2F1 expression), B13 (mediates tamoxifen resistance: suppresses ER α and induces IL-6 expression activating the mTOR pathway via STAT3), C8 (increased cadherin-11 expression), C10 (increased NF- κ B signalling, recruits homologous repair proteins), D3 (increased integrin α v and β 3 expression, integrin β 3-mediated wnt/ β -catenin signalling)
Clear cell renal cell carcinoma	A6 (reduced PI3K/Akt signalling), A11 (reduced wnt signalling), D1 (reduced TGF- β and wnt signalling)	
Pancreatic	D10 (reduced expression of survivin VEGF, MMP14 and N cadherin)	A10 (MMP3 expression via TGF- β 2-mediated activation of the p38 MAPK pathway), B5 (increased GSK3 β / β -catenin signalling), B7 (increased ERK signalling; reduced BAX and BAD expression), B9

(Continues)

TABLE 1 (Continued)

Cancer	Tumour suppressor function	Oncogenic function
Bladder	D10 (increased E-cadherin expression and reduced MMP14 expression)	A10 (increased FOSL1 and MMP3 expression)
Gastric	B9 (suppression of phosphorylated-Akt and NF- κ B-dependent Snail expression), D10 (direct transcriptional activation of IGFBP3 which in turn inhibits MMP14, uPA and uPAR; reduces RhoC-AKT signalling)	A10 (increased JAK1/STAT3 signalling and BCL2 expression), A13 (downregulation of Erk1/2; downregulation of DHRS2 leading to increased MDM2 expression; increased wnt/ β -catenin signalling), B5 (induces invasion and migration through direct transcriptional upregulation of β -catenin, as well as its downstream target genes cyclin D1 and c-Myc), B7 (activates EMT through the Src-FAK pathway; increased pAKT and pMAPKs levels; B7 knockdown downregulates pAkt and upregulates PTEN; increased PIK3R3/AKT signalling), B8 (increased EMT via elevated ZEB2 expression), C6 (increased MMP9 expression), C10 (increased ATM/NF- κ B and MAPK signalling; increased interleukin-6, TNF- α , TGF- β and EGF expression), D9 (increased expression of RUFY3)
Prostate	A10, B13 (inhibition of AR by direct binding to TCF4 -TCF4 target genes cmyc and cyclin D1 also inhibited), D13 (reduced SMAD1 expression)	B3 (increased CDCA3 expression), B9 (increased PI3K/AKT signalling), B13 (increased CCL2/CCR2 cytokine and integrin signalling; increased MAPK signalling, increased ZnT zinc output transporter expression leading to reduced intracellular zinc concentrations and activation of NF- κ B-mediated signalling), C4, C6 (increased NEP and IGFBP-3 expression, direct regulation of BMP7, GFR2, IGFBP3 and PDGFRA), C8 (increased expression of SRC-3, a member of the SRC/p160 steroid receptor cofactor family)
Osteosarcoma	B1 (reduced NF- κ B signalling)	B7 (increased expression of MMP2, MMP7, p-PI3K and p-Akt), B8 (increased wnt/ β -catenin signalling), C8 (increased MMP9 expression), C10 (increased expression of Bcl-2, MMP2 and MMP9, reduced expression of caspase 3 and E-cadherin)
Head and neck squamous cell carcinoma		B5 (HOXB5 directly binds to the promoter region of EGFR and consequently increases Akt/wnt/ β -catenin signalling), C6 (increases BCL2 expression by direct promoter binding), D10

Note: HOX genes are listed if there is experimental evidence for them having either a tumour suppressor or oncogenic function in cancer. The key target genes and/or signalling pathways regulated by each HOX gene are shown in brackets if they have been clearly identified in the literature.

Abbreviations: DAPK1, death-associated protein kinase 1; EMT, epithelial to mesenchymal transition; ER, oestrogen receptor; IGFBP-3, insulin-like growth factor binding protein-3; ITGA2, gene encoding integrin A2; lncRNA, long noncoding RNA; PDPK1, 3-phosphoinositide-dependent protein kinase 1; NEP, neutral endopeptidase; SAMD9, sterile alpha motif domain-containing protein 9; VASP, vasodilator-stimulated phosphoprotein; VEGFR, vascular endothelial growth factor receptor.

tumour suppressor activity seems to be dependent only on cancer type, as it is reportedly oncogenic in glioma⁷⁵ and oesophageal squamous cell cancer,⁸³ but acts as a tumour suppressor in colorectal⁷⁸ and breast cancer.^{73,81} This might reflect the relative dependency of different signalling pathways in different cancers that are activated or repressed by downstream targets of HOXA5, although the wnt/ β -catenin pathway for example is activated by HOXA5 in oesophageal squamous cell cancer (in which it acts as an oncogene),⁸³ but repressed by HOXA5 in colorectal cancer (in which it acts as a tumour suppressor),⁷⁸ indicating that the explanation may be more complex. Further analysis is made difficult by the relative scarcity of mechanistic studies on HOXA5. However, considerably more has been published on HOXB13. In studies where HOXB13 is identified as promoting oncogenesis, it is frequently because it has a role in driving metastasis. In prostate cancer, this is through increasing the expression of integrin subunits (ITGAV and ITGB1) specific to prostate cancer bone metastasis,⁹⁶ by preventing the expression of prostate-derived Ets factor (PDEF) which inhibits metastasis,⁹⁰ through

blocking the transport of zinc ions which in turn increases NF- κ B-mediated signalling by reducing inhibitor of NF- κ B alpha ($\text{I}\kappa\text{B}\alpha$) activity,⁹² and by promoting expression of the epithelial to mesenchymal transition (EMT)-inducing Slug transcription factor.¹⁰⁵ Conversely, tumour-suppressor functions of HOXB13 in prostate cancer seem to depend on its ability to block cell division through the downregulation of cyclin D1 through competition for TCF4 binding to its promoter,^{87,88} and androgen signalling through direct interaction with the androgen receptor.^{89,122} Taken together, it would seem that high levels of HOXB13 expression in tumours may drive initial tumour growth but suppress subsequent metastasis. It should be noted though that there are several studies that conflict with this. For example, the G84E mutation in HOXB13 is thought to promote prostate cancer initiation, but not progression and metastasis.¹²³ However, this mutation is thought to potentially weaken the interaction of HOXB13 with its MEIS cofactor, and the HOXB13/MEIS interaction in turn has been shown to reduce prostate cancer metastasis by blocking the expression of specific proteoglycans.¹⁰⁰

As discussed above, HOXD10 is exceptional amongst the HOX genes in acting solely as a tumour suppressor—there have been no functional studies of its mechanism published to our knowledge that do not report tumour suppressor activity, with the exception of HNSCC in which it seems to reduce cell invasion but increase cell proliferation.¹²⁴ It is noteworthy though that its paralog in the C cluster, HOXC10, is one of a small group of HOX genes for which only pro-oncogenic functions have been reported. Comparing the protein sequences of these two transcription factors using the BlastP application in PubMed (HOXC10—NP_059105 vs HOXD10—NP_002139) reveals that there is limited sequence identity outside of the homeodomain. This suggests that both proteins bind the same sequences in DNA, in which case the simplest explanation for their contrasting functions would be that they compete with each other to activate or repress target genes. However, comparing the target genes and pathways of HOXC10 and HOXD10 (Figure 1) suggests this may not be the case. Although there are a few common targets, mainly genes involved in the EMT^{55,66,70,71,115,117} and in PI3K/Akt signalling,^{58,68,70,119,120} the majority of targets do not overlap. Hence HOXC10 activates the expression of the pro-survival gene BCL2 and inhibits the pro-apoptotic genes Bax and caspase 3,^{71,125} while HOXD10 inhibits the expression of the anti-apoptotic gene survivin.¹¹¹ Likewise, HOXC10 activates genes involved in the NF- κ B pathway,⁷² while there is no evidence that HOXD10 has the opposite function. Thus, the opposing functions of HOXC10 and HOXD10 may not relate to a competition for binding to promoters and enhancers of the same target genes, but may instead represent largely independent mechanisms.

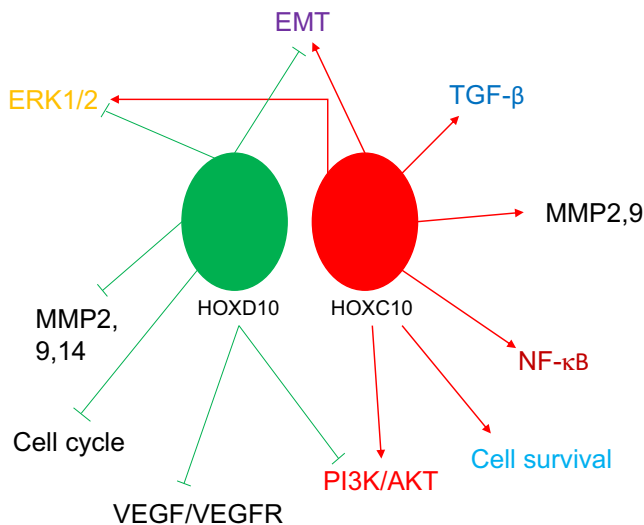

FIGURE 1 Target genes and pathways of HOXC10 and HOXD10. HOXC10 and its paralog HOXD10 have exclusively pro-oncogenic and tumour suppressor functions, respectively. With the exception of the ERK1/2 and PI3K/AKT signalling pathways and genes involved in the epithelial to mesenchymal transition (EMT), there is little overlap in target genes. Arrows indicate activation of target genes and lines ending with a bar indicate repression [Color figure can be viewed at wileyonlinelibrary.com]

3 | HOX GENES REGULATE DISCRETE FUNCTIONAL GROUPS OF GENES

From the currently available literature related to mechanistic studies of HOX genes in cancer, 13 distinct groups of targets can be identified that relate to specific functional subsets of genes (eg, EMT or apoptosis) or different signalling pathways (Figure 2). While some functions are mediated by HOX genes located throughout the clusters, others are restricted to smaller groups of paralog genes (Figure 3). For example, while HOX genes from across the whole cluster are involved in regulation of wnt/ β -catenin signalling,^{22,27,49,51,83,126-140} for other HOX target pathways regulation is by a far more restricted group of genes. The later include the matrix metalloproteinases (MMPs), one of the most common HOX targets, which are only regulated by HOX genes from paralogous groups 6 to 10,^{20,37,43,51,70,71,110,111,113,115,117,118,141-146} while integrins are regulated by paralog group genes 3 to 5,^{140,147-152} and targets related to the NF- κ B/p65 signalling pathway by groups 9 to 13.^{63,67,72,92,94,139}

The most commonly reported targets of HOX proteins are genes involved in the EMT (Figure 4). These include vimentin, an intermediate filament protein characteristic of epithelial cells, which is downregulated by HOXB9 in ovarian cancer,¹⁴⁴ HOXC10 in lung cancer,⁷⁰ HOXB8 in colorectal cancer^{51,53} and HOXB7 in breast cancer.⁴¹ E-cadherin, another transmembrane protein expressed in epithelial cells, is also downregulated by multiple HOX genes in different cancers,^{41,53,55,70,71,148,152-154} while its counterpart in mesenchymal cells, N-cadherin, is upregulated.^{53,55,111,148,155} Other HOX targets in EMT are the key transcription factors that promote this process—Snail, Slug and ZEB1/2. Notably, HOXB7 and HOXB8 are the most frequently linked to EMT—HOXB7 has been shown to regulate the expression of vimentin, claudin and E-cadherin,⁴¹ while HOXB8 regulates E-cadherin, N-cadherin, vimentin^{51,53} and ZEB1/2.^{48,53} The second largest sets of HOX targets, the MMPs, are also involved in the EMT through their ability to remodel the extracellular matrix. MMP9 is upregulated by HOXB9 in ovarian¹⁴⁴ and lung cancer,¹⁴⁵ and by HOXC6 in gastric cancer,¹⁴¹ while MMP2 is upregulated by HOXB7¹⁴⁶ and HOXC10⁷⁰ in lung cancer, HOXB8 in colorectal cancer⁵¹ and HOXC10 in osteosarcoma.⁷¹ Notably, in cases where HOX genes seem to have a tumour suppressor function involving MMPs, the target of regulation is often MMP14 rather than MMP2 or MMP9. MMP14 is repressed by HOXD10 in pancreatic cancer,¹¹¹ bladder cancer¹¹⁵ and glioma,¹¹³ while there is no evidence that it is activated by any of the other HOX proteins.

Other functional groupings of genes regulated by HOX proteins in cancer involve regulators of apoptosis, and in particular, caspase 3 that is repressed by HOXC13 in oesophageal cancer¹²⁵ and HOXC10 in osteosarcoma,⁷¹ Bax that is upregulated by HOXC10 in osteosarcoma⁷¹ and the anti-apoptotic gene BCL2 that is upregulated by HOXA10 in gastric cancer,¹⁵⁶ HOXC10 in osteosarcoma⁷¹ and HOXC6 in HNSCC.¹⁵⁷ In a similar finding as for the MMPs, the only reported tumour suppressor function for a HOX gene involving apoptosis acts on a different target; HOXD10 has been shown to block the expression of the anti-apoptotic gene survivin in pancreatic cancer.¹¹¹

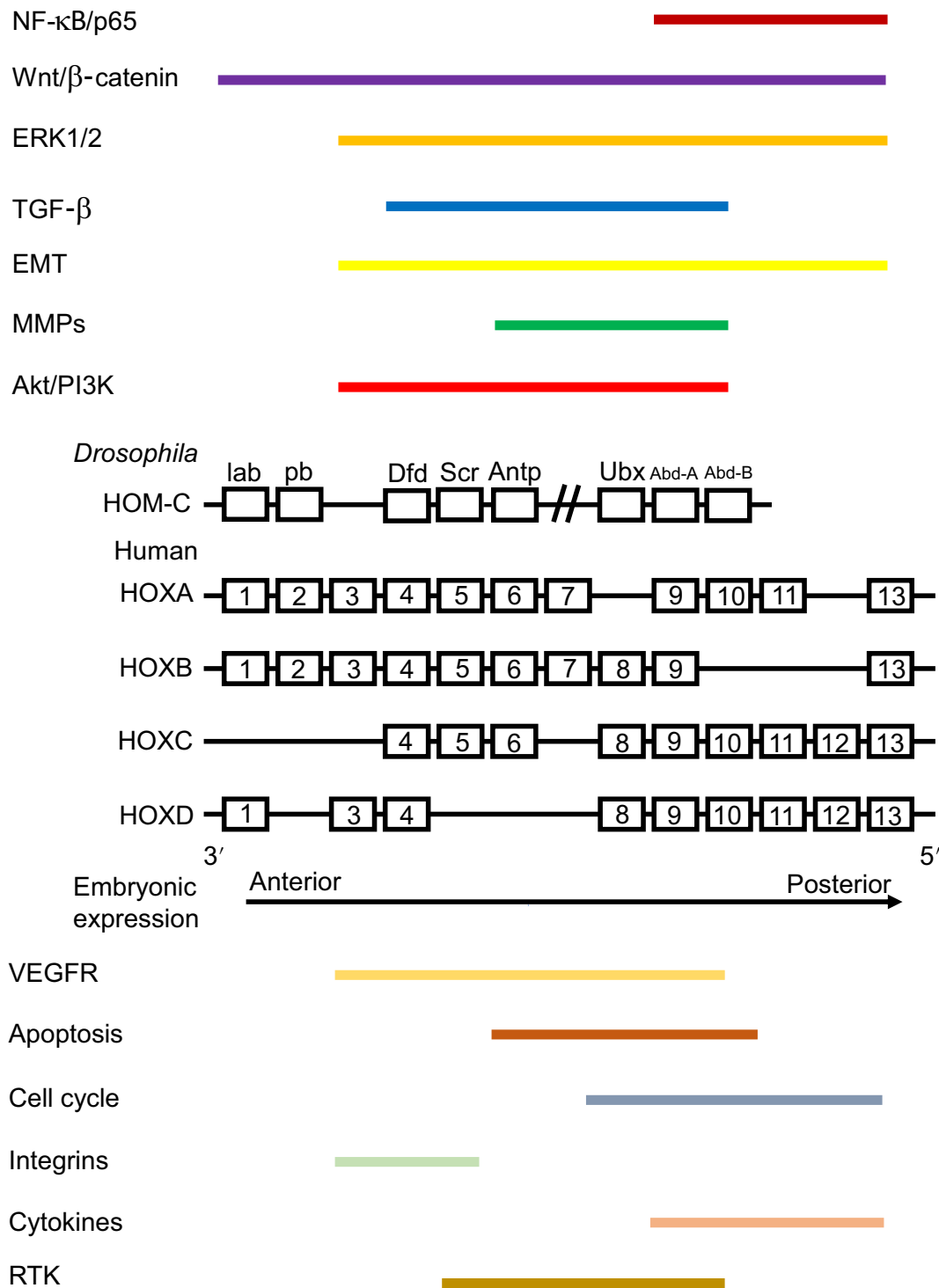
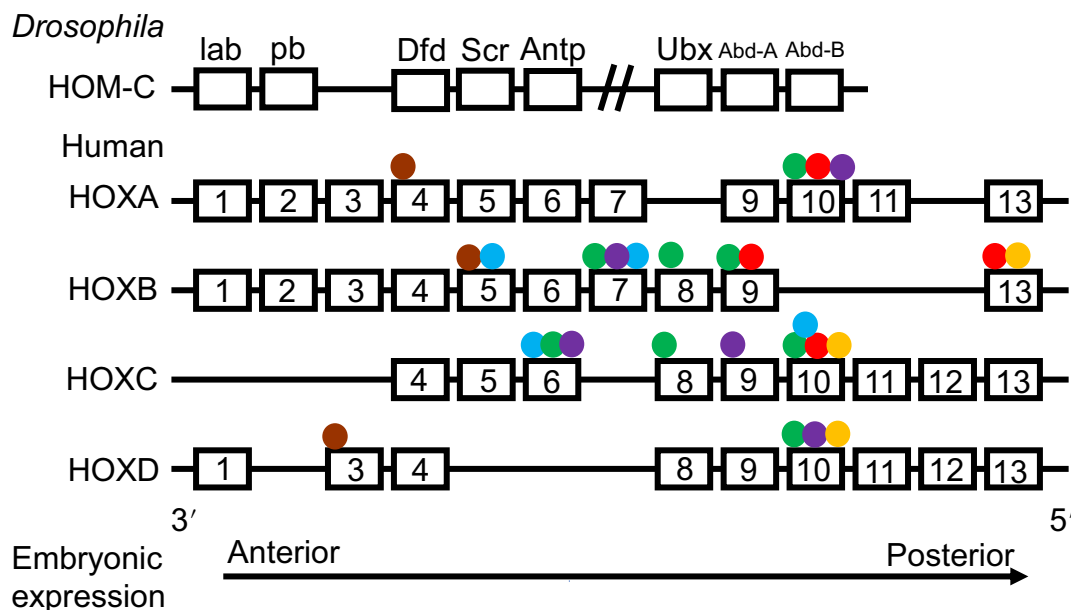

FIGURE 2 Mapping groups of functionally-related target genes to HOX genes within each cluster. While some functional groups, for example, genes involved in wnt/ β -catenin signalling, are regulated by HOX genes throughout the clusters, others such as integrins are regulated by a relatively small group of genes [Color figure can be viewed at wileyonlinelibrary.com]

The other functionally discrete sets of genes regulated by HOX genes in cancer are the integrins, cell cycle components, vascular endothelial growth factor (VEGF) and vascular endothelial growth factor receptor (VEGFR) (angiogenesis) and components of the TGF- β , wnt/ β -catenin, receptor tyrosine kinase (RTK), Akt/PI3K,

NF- κ B/p65 and cytokine (JAK/STAT) signalling pathways. Of these, the canonical wnt/ β -catenin pathway is the most common target of HOX regulation, being upregulated in lung cancer (HOXB5^{134,138} and HOXB9^{130,132}), colorectal cancer (HOXB8),⁵¹ breast cancer (HOXD3),¹⁴⁰ gastric cancer (HOXA13¹⁵⁸ and HOXB5¹²⁹), pancreatic



Integrins MMPs Cytokines EGFR Apoptosis NF- κ B

FIGURE 3 Mapping of HOX target genes that are involved in integrin function, cytokine/EGFR/NF- κ B signalling, or apoptosis, or which belong to the integrin or matrix metalloproteinase (MMP) families

cancer (HOXB5),¹⁵⁹ osteosarcoma (HOXB8)⁴⁹ and HNSCC (HOXB5).¹³¹ HOXB13 suppresses wnt/ β -catenin signalling in colon cancer, hence exhibiting a tumour suppressor function in this context, but does so through inhibiting transcription of the TCF4 gene (the product of which encodes a cofactor for β -catenin).¹⁰³

4 | DIRECT HOX TARGETS

Amongst the publications that report mechanistic studies for the role of HOX genes in cancer, 28 provide experimental evidence for direct regulation of target genes (ie, HOX protein binding to the promoter/enhancer regions that is required to activate or repress transcription). Notably, all of these identify a pro-oncogenic role for the HOX protein(s) being studied (Table 1). The directly regulated targets identified in these studies are summarised in Figure 5. With the exception of EGFR, which is upregulated by both HOXB5¹⁶⁰ and HOXB7,^{30,31} the HOX gene targets do not overlap but instead seem to be specific to individual HOX genes. However, there is a high degree of functional overlap mainly related to pro-oncogenic pathways, so for example, in addition to EGFR, other RTKs that are upregulated include HER2 and VEGFR, by HOXB7³⁰ and HOXD3,¹⁶¹ respectively.

A particularly notable finding is that HOXC10 can activate the transcription of two genes involved in immune suppression—Programmed Death Protein-Ligand 2 (PD-L2) and Tryptophan 2,3-Dioxygenase (TDO2)—by binding directly to their promoters.⁶⁴ PD-L2 can bind to the PD-1 receptor on T-cells to block their activation,¹⁶² and TDO2 converts tryptophan to kynurenine, which

also has an inhibitory effect on T-cells.¹⁶³ Elevated HOXC10 and TDO2 expression in glioma are both associated with immune suppression that supports tumour progression, indicating that HOX genes have functions in immunosuppression in addition to the other pro-oncogenic roles described above.⁶⁴

5 | IMPLICATIONS FOR CANCER TREATMENT

Individual HOX genes have been identified as possible therapeutic targets in cancer based on their pro-oncogenic function. However, there are a number of difficulties with this approach. One of these is the high degree of functional redundancy amongst HOX genes with respect to downstream target genes in cancer. Examples of these are discussed above but include genes involved in the EMT, where, with the possible exception of Claudin, target genes are regulated by two or more HOX proteins, and for E-cadherin by at least six HOX proteins. One approach to overcoming this is to target multiple HOX proteins through their interaction with PBX using an inhibitory peptide (HXR9) that acts as a competitive antagonist by mimicking the conserved hexapeptide region in HOX paralogue group proteins 1 to 10 that mediates PBX binding.¹⁶⁴ HXR9 has been shown to cause apoptosis in a range of cancers both in vitro and in vivo, including prostate,⁸ breast,⁹ lung,¹⁰ renal,¹¹ ovarian,¹⁶⁵ oral¹² and oesophageal cancer,¹⁶⁶ as well as mesothelioma,¹⁴ myeloma,¹⁶⁷ melanoma^{168,169} and acute myeloid leukaemia.¹⁷⁰ A potential difficulty with this approach though is the apparent tumour suppressor function of some

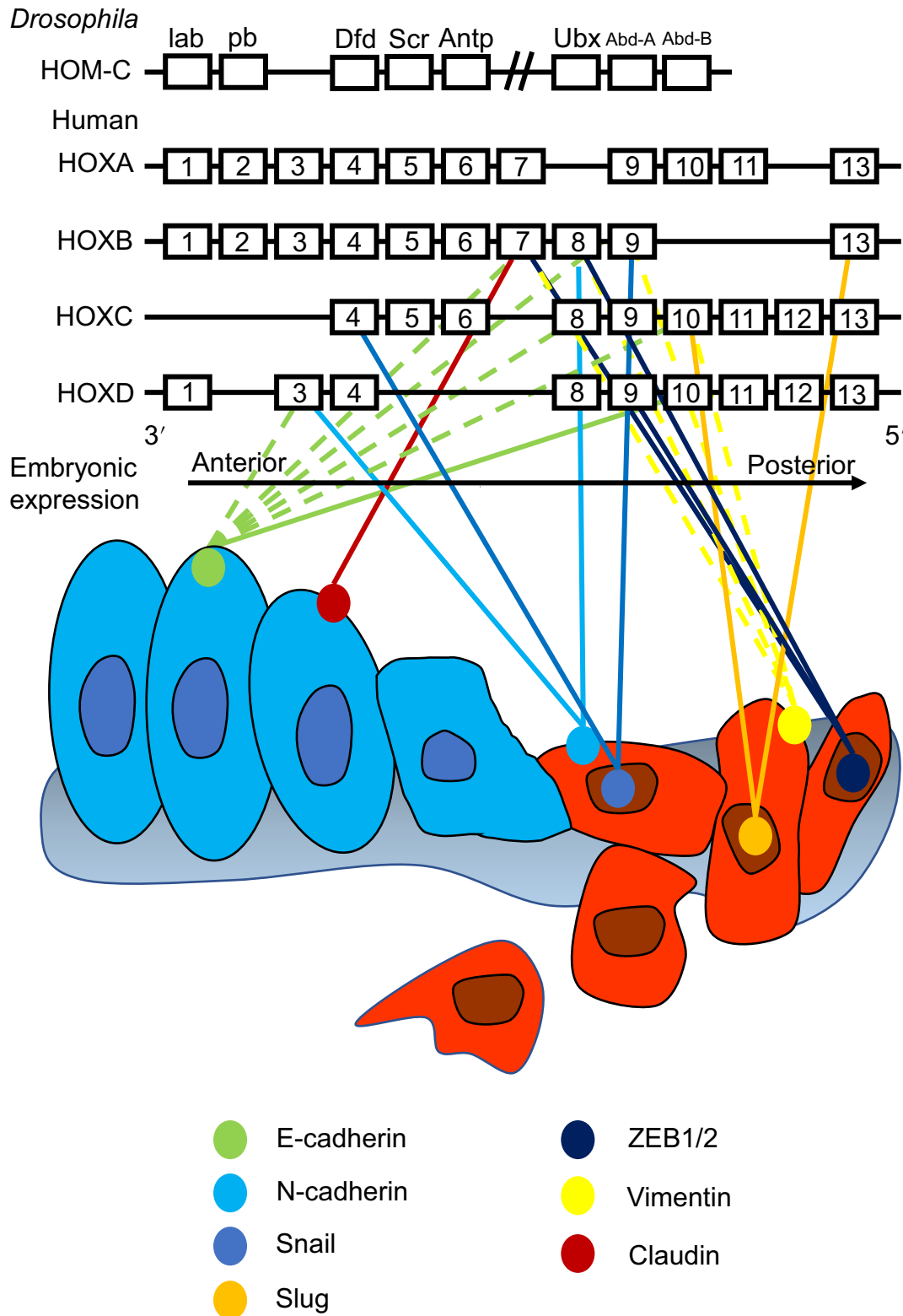

FIGURE 4 HOX target genes involved in the epithelial to mesenchymal transition (EMT). Solid lines indicate that the target gene is upregulated by the indicated HOX transcription factor while dashed lines denote repression. Vimentin, an intermediate filament protein characteristic of epithelial cells, is downregulated by HOXB9, HOXC10, HOXB8 and HOXB7. E-cadherin, another transmembrane protein expressed in epithelial cells is also downregulated by multiple HOX genes in different cancers, with the exception of HOXD10 that activates its transcription, while its counterpart in mesenchymal cells, N-cadherin, is upregulated by HOXD3 and HOXB8. Other upregulated HOX targets in EMT are the key transcription factors that promote this process—Snail (HOXB9 and HOXC4), Slug (HOXB13 and HOXC10) and ZEB1/2 (HOXB7, HOXB8 and HOXD9)

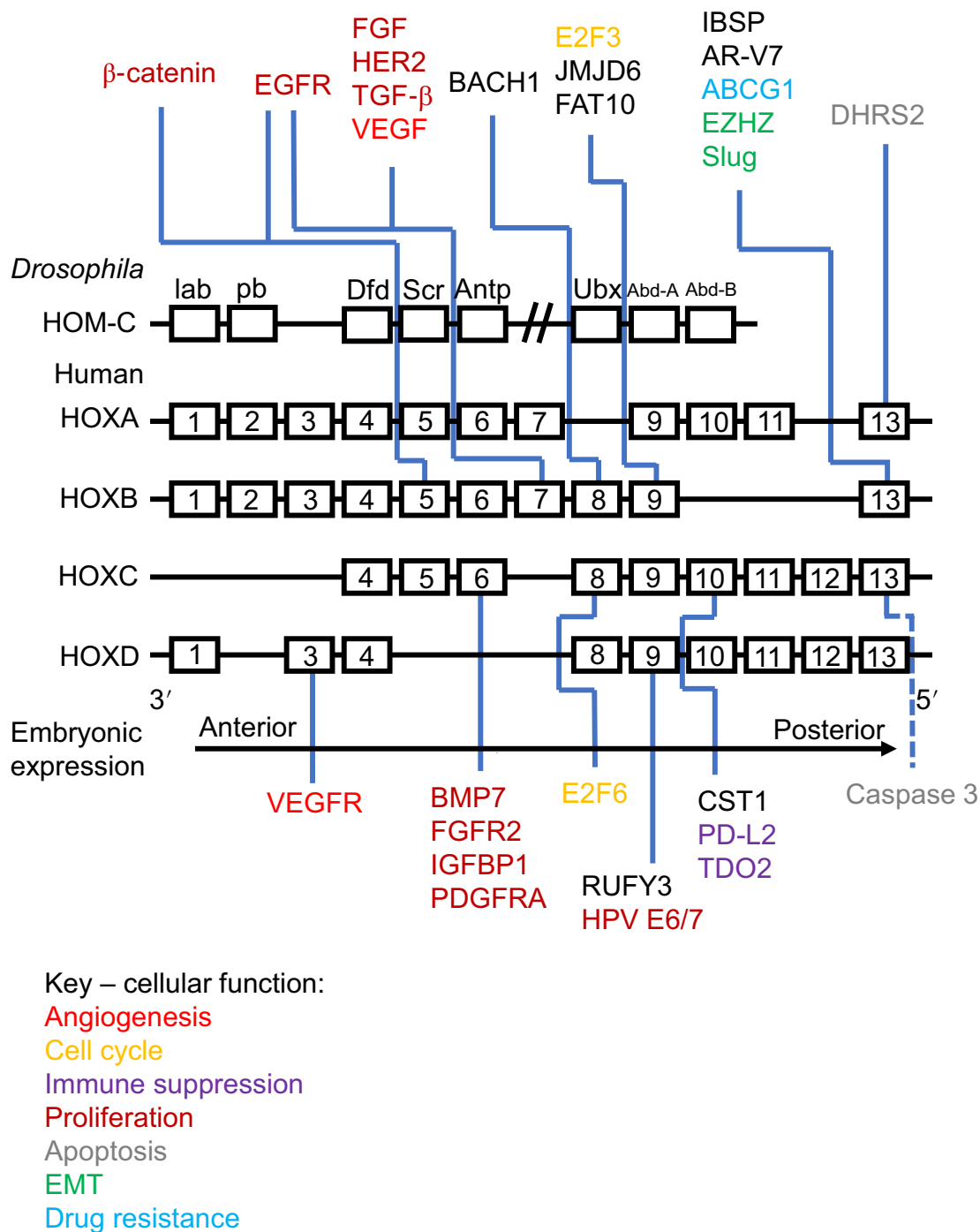

FIGURE 5 HOX target genes for which there is experimental evidence for HOX protein binding to the promoter/enhancer region, and a requirement for this binding for gene regulation. All the target genes are upregulated by HOX transcription factors, with the exception of caspase 3 which is repressed by HOXC13

HOX genes, although, as described above, this is mainly reported from associative rather than mechanistic studies, with evidence from the latter strongly indicating a primarily pro-oncogenic role for HOX genes.

An alternative would be a targeted approach using small-molecule inhibitors based on the HOX expression profile of individual tumours. Previous work has focused on developing in vitro, cell-based screens

for drugs that target dysregulated HOX expression, and identified the histone deacetylase inhibitor Entinostat as a selective agent for leukaemia cells expressing high levels of HOX genes together with their TALE transcription factors.¹⁷¹ Effective, direct targeting of HOX transcription factors by small molecules has so far proved elusive, which is due in part to the lack of structural data for the majority of HOX proteins, and the inherent difficulty of targeting transcription factors that

generally interact through large hydrophobic surfaces. However, the recent development of the AI-driven AlphaFold model for predicting protein structures¹⁷² together with proteasome-targeting technology may help facilitate this approach.¹⁷³

6 | CONCLUSIONS

The role of HOX genes in cancer has now been extensively studied, although this has resulted in a number of apparently contradictory findings, especially the conflicting roles of HOX genes as tumour suppressors vs promoters of oncogenesis. In order to better understand the mechanisms by which HOX genes act in cancer, we have considered only those studies that provide experimental evidence for HOX function, rather than associative studies restricted to the relationship between HOX expression and clinical outcomes. On this basis, it seems that the role of HOX genes in cancer is predominantly pro-oncogenic, with the exception only of HOXD10. Furthermore, when grouped together by function, many target genes are regulated by only a few HOX proteins. This indicates that while HOX proteins are potential therapeutic targets in cancer, this may ultimately depend on an approach rooted in personalised medicine that adapts to the HOX expression profiles of individual tumours.

CONFLICT OF INTEREST

The authors have no conflicts of interest to declare.

ORCID

Richard Morgan  <https://orcid.org/0000-0002-8721-4479>

REFERENCES

- Gehring WJ. Homeo boxes in the study of development. *Science*. 1987;236(4806):1245-1252.
- Mallo M, Wellik DM, Deschamps J. Hox genes and regional patterning of the vertebrate body plan. *Dev Biol*. 2010;344(1):7-15.
- Holland PW, Booth HA, Bruford EA. Classification and nomenclature of all human homeobox genes. *BMC Biol*. 2007;5:47.
- Longobardi E, Penkov D, Mateos D, De Florian G, Torres M, Blasi F. Biochemistry of the tale transcription factors PREP, MEIS, and PBX in vertebrates. *Dev Dyn*. 2014;243(1):59-75.
- Yang Q, Zhang Q, Zhang X, et al. HoxA10 facilitates SHP-1-catalyzed dephosphorylation of p38 MAPK/STAT3 to repress hepatitis B virus replication by a feedback regulatory mechanism. *J Virol*. 2019;93(7):e01607-18.
- Primon M, Hunter KD, Pandha HS, Morgan R. Kinase regulation of HOX transcription factors. *Cancers (Basel)*. 2019;11(4):508.
- Song J, Wang T, Xu W, et al. HOXB9 acetylation at K27 is responsible for its suppression of colon cancer progression. *Cancer Lett*. 2018;426:63-72.
- Morgan R, Boxall A, Harrington KJ, Simpson GR, Michael A, Pandha HS. Targeting HOX transcription factors in prostate cancer. *BMC Urol*. 2014;14:17.
- Morgan R, Boxall A, Harrington KJ, et al. Targeting the HOX/PBX dimer in breast cancer. *Breast Cancer Res Treat*. 2012;136(2):389-398.
- Plowright L, Harrington KJ, Pandha HS, Morgan R. HOX transcription factors are potential therapeutic targets in non-small-cell lung cancer (targeting HOX genes in lung cancer). *Br J Cancer*. 2009;100(3):470-475.
- Shears L, Plowright L, Harrington K, Pandha HS, Morgan R. Disrupting the interaction between HOX and PBX causes necrotic and apoptotic cell death in the renal cancer lines CaKi-2 and 769-P. *J Urol*. 2008;180(5):2196-2201.
- Platais C, Radhakrishnan R, Ebersberger SN, Morgan R, Lambert DW, Hunter KD. Targeting HOX-PBX interactions causes death in oral potentially malignant and squamous carcinoma cells but not normal oral keratinocytes. *BMC Cancer*. 2018;18(1):723.
- Morgan R, Plowright L, Harrington KJ, Michael A, Pandha HS. Targeting HOX and PBX transcription factors in ovarian cancer. *BMC Cancer*. 2010;10:89.
- Morgan R, Simpson G, Gray S, et al. HOX transcription factors are potential targets and markers in malignant mesothelioma. *BMC Cancer*. 2016;16:85.
- Braig S, Mueller DW, Rothhammer T, Bosserhoff AK. MicroRNA miR-196a is a central regulator of HOX-B7 and BMP4 expression in malignant melanoma. *Cell Mol Life Sci*. 2010;67(20):3535-3548.
- Care A, Felicetti F, Meccia E, et al. HOXB7: a key factor for tumor-associated angiogenic switch. *Cancer Res*. 2001;61(17):6532-6539.
- Care A, Silvani A, Meccia E, et al. HOXB7 constitutively activates basic fibroblast growth factor in melanomas. *Mol Cell Biol*. 1996;16(9):4842-4851.
- Chen Z, Mo J, Brosseau JP, et al. Spatiotemporal loss of NF1 in Schwann cell lineage leads to different types of cutaneous neurofibroma susceptible to modification by the hippo pathway. *Cancer Discov*. 2019;9(1):114-129.
- Chile T, Fortes MA, Correa-Giannella ML, et al. HOXB7 mRNA is overexpressed in pancreatic ductal adenocarcinomas and its knock-down induces cell cycle arrest and apoptosis. *BMC Cancer*. 2013;13:451.
- Dai L, Hu W, Yang Z, et al. Upregulated expression of HOXB7 in intrahepatic cholangiocarcinoma is associated with tumor cell metastasis and poor prognosis. *Lab Invest*. 2019;99(6):736-748.
- Fernandez LC, Errico MC, Bottero L, et al. Oncogenic HoxB7 requires TALE cofactors and is inactivated by a dominant-negative Pbx1 mutant in a cell-specific manner. *Cancer Lett*. 2008;266(2):144-155.
- Gao D, Chen HQ. Specific knockdown of HOXB7 inhibits cutaneous squamous cell carcinoma cell migration and invasion while inducing apoptosis via the Wnt/beta-catenin signaling pathway. *Am J Physiol Cell Physiol*. 2018;315(5):C675-C686.
- He X, Liu Z, Xia Y, et al. HOXB7 overexpression promotes cell proliferation and correlates with poor prognosis in gastric cancer patients by inducing expression of both AKT and MARKs. *Oncotarget*. 2017;8(1):1247-1261.
- Heinonen H, Lepikhova T, Sahu B, et al. Identification of several potential chromatin binding sites of HOXB7 and its downstream target genes in breast cancer. *Int J Cancer*. 2015;137(10):2374-2383.
- How C, Hui AB, Alajez NM, et al. MicroRNA-196b regulates the homeobox B7-vascular endothelial growth factor axis in cervical cancer. *PLoS One*. 2013;8(7):e67846.
- Huan HB, Yang DP, Wen XD, et al. HOXB7 accelerates the malignant progression of hepatocellular carcinoma by promoting stemness and epithelial-mesenchymal transition. *J Exp Clin Cancer Res*. 2017;36(1):86.
- Huo XY, Zhang XY, Yuan F, Zhao XY, You BA. HOXB7 promotes proliferation and metastasis of glioma by regulating the Wnt/beta-catenin pathway. *Eur Rev Med Pharmacol Sci*. 2019;23(6):2476-2485.
- Jin K, Kong X, Shah T, et al. The HOXB7 protein renders breast cancer cells resistant to tamoxifen through activation of the EGFR pathway. *Proc Natl Acad Sci USA*. 2012;109(8):2736-2741.

29. Jin K, Park S, Teo WW, et al. HOXB7 is an ERalpha cofactor in the activation of HER2 and multiple ER target genes leading to endocrine resistance. *Cancer Discov.* 2015;5(9):944-959.
30. Jin K, Sukumar S. A pivotal role for HOXB7 protein in endocrine resistant breast cancer. *Onco Targets Ther.* 2015;2(11):917-919.
31. Joo MK, Park JJ, Yoo HS, et al. The roles of HOXB7 in promoting migration, invasion, and anti-apoptosis in gastric cancer. *J Gastroenterol Hepatol.* 2016;31(10):1717-1726.
32. Liao WT, Jiang D, Yuan J, et al. HOXB7 as a prognostic factor and mediator of colorectal cancer progression. *Clin Cancer Res.* 2011;17(11):3569-3578.
33. Liu S, Jin K, Hui Y, et al. HOXB7 promotes malignant progression by activating the TGFbeta signaling pathway. *Cancer Res.* 2015;75(4):709-719.
34. Raval A, Tanner SM, Byrd JC, et al. Downregulation of death-associated protein kinase 1 (DAPK1) in chronic lymphocytic leukemia. *Cell.* 2007;129(5):879-890.
35. Rubin E, Wu X, Zhu T, et al. A role for the HOXB7 homeodomain protein in DNA repair. *Cancer Res.* 2007;67(4):1527-1535.
36. Soret C, Martin E, Duluc I, et al. Distinct mechanisms for opposite functions of homeoproteins Cdx2 and HoxB7 in double-strand break DNA repair in colon cancer cells. *Cancer Lett.* 2016;374(2):208-215.
37. Storti P, Donofrio G, Colla S, et al. HOXB7 expression by myeloma cells regulates their pro-angiogenic properties in multiple myeloma patients. *Leukemia.* 2011;25(3):527-537.
38. Tsuboi M, Taniuchi K, Shimizu T, Saito M, Saibara T. The transcription factor HOXB7 regulates ERK kinase activity and thereby stimulates the motility and invasiveness of pancreatic cancer cells. *J Biol Chem.* 2017;292(43):17681-17702.
39. Wang WM, Xu Y, Wang YH, et al. HOXB7 promotes tumor progression via bFGF-induced activation of MAPK/ERK pathway and indicated poor prognosis in hepatocellular carcinoma. *Oncotarget.* 2017;8(29):47121-47135.
40. Wu J, Long Z, Cai H, Yu S, Liu X. Homeobox B7 accelerates the cancer progression of gastric carcinoma cells by promoting epithelial-mesenchymal transition (EMT) and activating Src-FAK pathway. *Onco Targets Ther.* 2019;12:3743-3751.
41. Wu X, Chen H, Parker B, et al. HOXB7, a homeodomain protein, is overexpressed in breast cancer and confers epithelial-mesenchymal transition. *Cancer Res.* 2006;66(19):9527-9534.
42. Yang L, Xie F, Li S. Downregulation of homeobox B7 inhibits the tumorigenesis and progression of osteosarcoma. *Oncol Res.* 2017;25(7):1089-1095.
43. Yang Y, Chen J, Chen Q. Upregulation of HOXB7 promotes proliferation and metastasis of osteosarcoma cells. *Mol Med Rep.* 2017;16(3):2773-2778.
44. Yaron Y, McAdara JK, Lynch M, Hughes E, Gasson JC. Identification of novel functional regions important for the activity of HOXB7 in mammalian cells. *J Immunol.* 2001;166(8):5058-5067.
45. Yuan Z, Chen D, Chen X, Yang H, Wei Y. Overexpression of HOXB7 protein reduces sensitivity of oral cancer cells to chemo-radiotherapy. *Cancer Gene Ther.* 2016;23(12):419-424.
46. Zhong Y, Zhang Y, Ma D, Ren X, Xu C, Wan D. Inhibition of HOXB7 suppresses p27-mediated acute lymphoblastic leukemia by regulating basic fibroblast growth factor and ERK1/2. *Life Sci.* 2019;218:1-7.
47. Zhou T, Fu H, Dong B, et al. HOXB7 mediates cisplatin resistance in esophageal squamous cell carcinoma through involvement of DNA damage repair. *Thorac Cancer.* 2020;11(11):3071-3085.
48. Ding WJ, Zhou M, Chen MM, Qu CY. HOXB8 promotes tumor metastasis and the epithelial-mesenchymal transition via ZEB2 targets in gastric cancer. *J Cancer Res Clin Oncol.* 2017;143(3):385-397.
49. Guo J, Zhang T, Dou D. Knockdown of HOXB8 inhibits tumor growth and metastasis by the inactivation of Wnt/beta-catenin signaling pathway in osteosarcoma. *Eur J Pharmacol.* 2019;854:22-27.
50. Knoepfler PS, Sykes DB, Pasillas M, Kamps MP. HoxB8 requires its Pbx-interaction motif to block differentiation of primary myeloid progenitors and of most cell line models of myeloid differentiation. *Oncogene.* 2001;20(39):5440-5448.
51. Li X, Lin H, Jiang F, Lou Y, Ji L, Li S. Knock-down of HOXB8 prohibits proliferation and migration of colorectal cancer cells via Wnt/beta-catenin signaling pathway. *Med Sci Monit.* 2019;25:711-720.
52. Ma W, Jin H, Liu W, et al. Homeobox B8 targets sterile alpha motif domain-containing protein 9 and drives Glioma progression. *Neurosci Bull.* 2020;36(4):359-371.
53. Wang T, Lin F, Sun X, et al. HOXB8 enhances the proliferation and metastasis of colorectal cancer cells by promoting EMT via STAT3 activation. *Cancer Cell Int.* 2019;19:3.
54. Ying Y, Wang Y, Huang X, et al. Oncogenic HOXB8 is driven by MYC-regulated super-enhancer and potentiates colorectal cancer invasiveness via BACH1. *Oncogene.* 2020;39(5):1004-1017.
55. Dai BW, Yang ZM, Deng P, et al. HOXC10 promotes migration and invasion via the WNT-EMT signaling pathway in oral squamous cell carcinoma. *J Cancer.* 2019;10(19):4540-4551.
56. Dang Y, Chen J, Feng W, et al. Interleukin 1beta-mediated HOXC10 overexpression promotes hepatocellular carcinoma metastasis by upregulating PDPK1 and VASP. *Theranostics.* 2020;10(8):3833-3848.
57. Feng X, Li T, Liu Z, Shi Y, Peng Y. HOXC10 up-regulation contributes to human thyroid cancer and indicates poor survival outcome. *Mol Biosyst.* 2015;11(11):2946-2954.
58. Guan Y, He Y, Lv S, Hou X, Li L, Song J. Overexpression of HOXC10 promotes glioblastoma cell progression to a poor prognosis via the PI3K/AKT signalling pathway. *J Drug Target.* 2019;27(1):60-66.
59. Guerra SL, Maertens O, Kuzmickas R, et al. A deregulated HOX gene Axis confers an epigenetic vulnerability in KRAS-mutant lung cancers. *Cancer Cell.* 2020;37(5):705-19.e6.
60. Guo C, Hou J, Ao S, Deng X, Lyu G. HOXC10 up-regulation promotes gastric cancer cell proliferation and metastasis through MAPK pathway. *Chin J Cancer Res.* 2017;29(6):572-580.
61. He J, Ge Q, Lin Z, et al. MiR-129-5p induces cell cycle arrest through modulating HOXC10/Cyclin D1 to inhibit gastric cancer progression. *FASEB J.* 2020;34(6):8544-8557.
62. Kim J, Bae DH, Kim JH, Song KS, Kim YS, Kim SY. HOXC10 overexpression promotes cell proliferation and migration in gastric cancer. *Oncol Rep.* 2019;42(1):202-212.
63. Li J, Tong G, Huang C, et al. HOXC10 promotes cell migration, invasion, and tumor growth in gastric carcinoma cells through upregulating proinflammatory cytokines. *J Cell Physiol.* 2020;235(4):3579-3591.
64. Li S, Zhang W, Wu C, et al. HOXC10 promotes proliferation and invasion and induces immunosuppressive gene expression in glioma. *FEBS J.* 2018;285(12):2278-2291.
65. Miwa T, Kanda M, Umeda S, et al. Homeobox C10 influences on the malignant phenotype of gastric cancer cell lines and its elevated expression positively correlates with recurrence and poor survival. *Ann Surg Oncol.* 2019;26(5):1535-1543.
66. Peng Y, Li Y, Li Y, et al. HOXC10 promotes tumour metastasis by regulating the EMT-related gene Slug in ovarian cancer. *Aging (Albany NY).* 2020;12(19):19375-19398.
67. Sadik H, Korangath P, Nguyen NK, et al. HOXC10 expression supports the development of chemotherapy resistance by fine tuning DNA repair in breast cancer cells. *Cancer Res.* 2016;76(15):4443-4456.
68. Suo D, Wang Z, Li L, et al. HOXC10 upregulation confers resistance to chemoradiotherapy in ESCC tumor cells and predicts poor prognosis. *Oncogene.* 2020;39(32):5441-5454.
69. Tan Z, Chen K, Wu W, et al. Overexpression of HOXC10 promotes angiogenesis in human glioma via interaction with PRMT5 and upregulation of VEGFA expression. *Theranostics.* 2018;8(18):5143-5158.

70. Tang XL, Ding BX, Hua Y, et al. HOXC10 promotes the metastasis of human lung adenocarcinoma and indicates poor survival outcome. *Front Physiol.* 2017;8:557.
71. Xiong W, Zhou Q, Liu G, Liu XS, Li XY. Homeodomain-containing gene 10 inhibits cell apoptosis and promotes cell invasion and migration in osteosarcoma cell lines. *Tumour Biol.* 2017;39(5):1010428317697566.
72. Yao S, He L, Zhang Y, et al. HOXC10 promotes gastric cancer cell invasion and migration via regulation of the NF-kappaB pathway. *Biochem Biophys Res Commun.* 2018;501(3):628-635.
73. Chen H, Chung S, Sukumar S. HOXA5-induced apoptosis in breast cancer cells is mediated by caspases 2 and 8. *Mol Cell Biol.* 2004;24(2):924-935.
74. Chen H, Rubin E, Zhang H, et al. Identification of transcriptional targets of HOXA5. *J Biol Chem.* 2005;280(19):19373-19380.
75. Cimino PJ, Kim Y, Wu HJ, et al. Increased HOXA5 expression provides a selective advantage for gain of whole chromosome 7 in IDH wild-type glioblastoma. *Genes Dev.* 2018;32(7-8):512-523.
76. Gao F, Liu W, Guo Q, Bai Y, Yang H, Chen H. Physcion blocks cell cycle and induces apoptosis in human B cell precursor acute lymphoblastic leukemia cells by downregulating HOXA5. *Biomed Pharmacother.* 2017;94:850-857.
77. Liao Y, Wang C, Yang Z, et al. Dysregulated Sp1/miR-130b-3p/HOXA5 axis contributes to tumor angiogenesis and progression of hepatocellular carcinoma. *Theranostics.* 2020;10(12):5209-5224.
78. Ordonez-Moran P, Dafflon C, Imajo M, Nishida E, Huelsken J. HOXA5 counteracts stem cell traits by inhibiting Wnt signaling in colorectal cancer. *Cancer Cell.* 2015;28(6):815-829.
79. Raman V, Tamori A, Vali M, Zeller K, Korz D, Sukumar S. HOXA5 regulates expression of the progesterone receptor. *J Biol Chem.* 2000;275(34):26551-26555.
80. Saijo H, Hirohashi Y, Torigoe T, et al. Plasticity of lung cancer stem-like cells is regulated by the transcription factor HOXA5 that is induced by oxidative stress. *Oncotarget.* 2016;7(31):50043-50056.
81. Stasinopoulos IA, Mironchik Y, Raman A, Wildes F, Winnard P Jr, Raman V. HOXA5-twist interaction alters p53 homeostasis in breast cancer cells. *J Biol Chem.* 2005;280(3):2294-2299.
82. Yang Y, Zhong F, Huang X, et al. High expression of HOXA5 is associated with poor prognosis in acute myeloid leukemia. *Curr Probl Cancer.* 2020;45:100673.
83. Zhang H, Zhao JH, Suo ZM. Knockdown of HOXA5 inhibits the tumorigenesis in esophageal squamous cell cancer. *Biomed Pharmacother.* 2017;86:149-154.
84. Baietti MF, Zhao P, Crowther J, et al. Loss of 9p21 regulatory hub promotes kidney cancer progression by upregulating HOXB13. *Mol Cancer Res.* 2021;19:979-990.
85. Berger A, Brady NJ, Bareja R, et al. N-Myc-mediated epigenetic reprogramming drives lineage plasticity in advanced prostate cancer. *J Clin Invest.* 2019;129(9):3924-3940.
86. Chen Z, Wu D, Thomas-Ahner JM, et al. Diverse AR-V7 cistromes in castration-resistant prostate cancer are governed by HoxB13. *Proc Natl Acad Sci USA.* 2018;115(26):6810-6815.
87. Hamid SM, Cicek S, Karamil S, et al. HOXB13 contributes to G1/S and G2/M checkpoint controls in prostate. *Mol Cell Endocrinol.* 2014;383(1-2):38-47.
88. Jung C, Kim RS, Lee SJ, Wang C, Jeng MH. HOXB13 homeodomain protein suppresses the growth of prostate cancer cells by the negative regulation of T-cell factor 4. *Cancer Res.* 2004;64(9):3046-3051.
89. Jung C, Kim RS, Zhang HJ, Lee SJ, Jeng MH. HOXB13 induces growth suppression of prostate cancer cells as a repressor of hormone-activated androgen receptor signaling. *Cancer Res.* 2004;64(24):9185-9192.
90. Kim IJ, Kang TW, Jeong T, Kim YR, Jung C. HOXB13 regulates the prostate-derived Ets factor: implications for prostate cancer cell invasion. *Int J Oncol.* 2014;45(2):869-876.
91. Kim YR, Kang TW, To PK, et al. HOXB13-mediated suppression of p21WAF1/CIP1 regulates JNK/c-Jun signaling in prostate cancer cells. *Oncol Rep.* 2016;35(4):2011-2016.
92. Kim YR, Kim IJ, Kang TW, et al. HOXB13 downregulates intracellular zinc and increases NF-kappaB signaling to promote prostate cancer metastasis. *Oncogene.* 2014;33(37):4558-4567.
93. Kim YR, Oh KJ, Park RY, et al. HOXB13 promotes androgen independent growth of LNCaP prostate cancer cells by the activation of E2F signaling. *Mol Cancer.* 2010;9:124.
94. Li RC, Ke S, Meng FK, et al. CiRS-7 promotes growth and metastasis of esophageal squamous cell carcinoma via regulation of miR-7/HOXB13. *Cell Death Dis.* 2018;9(8):838.
95. Miao J, Wang Z, Provencher H, et al. HOXB13 promotes ovarian cancer progression. *Proc Natl Acad Sci USA.* 2007;104(43):17093-17098.
96. Misawa A, Kondo Y, Takei H, Takizawa T. Long noncoding RNA HOXA11-AS and transcription factor HOXB13 modulate the expression of bone metastasis-related genes in prostate cancer. *Genes (Basel).* 2021;12(2):182.
97. Pomerantz MM, Qiu X, Zhu Y, et al. Prostate cancer reactivates developmental epigenomic programs during metastatic progression. *Nat Genet.* 2020;52(8):790-799.
98. Shah N, Jin K, Cruz LA, et al. HOXB13 mediates tamoxifen resistance and invasiveness in human breast cancer by suppressing ERalpha and inducing IL-6 expression. *Cancer Res.* 2013;73(17):5449-5458.
99. Sipeky C, Gao P, Zhang Q, et al. Synergistic interaction of HOXB13 and CIP2A predisposes to aggressive prostate cancer. *Clin Cancer Res.* 2018;24(24):6265-6276.
100. VanOpstall C, Perike S, Brechka H, et al. MEIS-mediated suppression of human prostate cancer growth and metastasis through HOXB13-dependent regulation of proteoglycans. *Elife.* 2020;9:e53600.
101. Wang X, Sun Y, Xu T, et al. HOXB13 promotes proliferation, migration, and invasion of glioblastoma through transcriptional upregulation of lncRNA HOXC-AS3. *J Cell Biochem.* 2019;120(9):15527-15537.
102. Wei J, Shi Z, Na R, et al. Germline HOXB13 G84E mutation carriers and risk to twenty common types of cancer: results from the UKbiobank. *Br J Cancer.* 2020;123(9):1356-1359.
103. Xie B, Bai B, Xu Y, et al. Tumor-suppressive function and mechanism of HOXB13 in right-sided colon cancer. *Signal Transduct Target Ther.* 2019;4:51.
104. Yao J, Chen Y, Nguyen DT, et al. The Homeobox gene, HOXB13, regulates a mitotic protein-kinase interaction network in metastatic prostate cancers. *Sci Rep.* 2019;9(1):9715.
105. Yuan H, Kajiyama H, Ito S, et al. HOXB13 and ALX4 induce SLUG expression for the promotion of EMT and cell invasion in ovarian cancer cells. *Oncotarget.* 2015;6(15):13359-13370.
106. Zhan J, Wang P, Li S, et al. HOXB13 networking with ABCG1/EZH2/Slug mediates metastasis and confers resistance to cisplatin in lung adenocarcinoma patients. *Theranostics.* 2019;9(7):2084-2099.
107. Zhang E, Han L, Yin D, et al. H3K27 acetylation activated-long non-coding RNA CCAT1 affects cell proliferation and migration by regulating SPRY4 and HOXB13 expression in esophageal squamous cell carcinoma. *Nucleic Acids Res.* 2017;45(6):3086-3101.
108. Zhang L, Wan Y, Zhang Z, et al. FTO demethylates m6A modifications in HOXB13 mRNA and promotes endometrial cancer metastasis by activating the WNT signalling pathway. *RNA Biol.* 2020;18(9):1265-1278.
109. Guo Y, Peng Y, Gao D, et al. Silencing HOXD10 by promoter region hypermethylation activates ERK signaling in hepatocellular carcinoma. *Clin Epigenetics.* 2017;9:116.
110. Li Q, Ding C, Chen C, et al. miR-224 promotion of cell migration and invasion by targeting Homeobox D 10 gene in human hepatocellular carcinoma. *J Gastroenterol Hepatol.* 2014;29(4):835-842.

111. Lin Z, Hu Y, Lin R, Ye H. The effect of overexpression of the HOXD10 gene on the malignant proliferation, invasion, and tumor formation of pancreatic cancer cell PANC-1. *Gland Surg.* 2020;9(2):385-391.
112. Reddy SD, Ohshiro K, Rayala SK, Kumar R. MicroRNA-7, a homeobox D10 target, inhibits p21-activated kinase 1 and regulates its functions. *Cancer Res.* 2008;68(20):8195-8200.
113. Sun L, Yan W, Wang Y, et al. MicroRNA-10b induces glioma cell invasion by modulating MMP-14 and uPAR expression via HOXD10. *Brain Res.* 2011;1389:9-18.
114. Wang Y, Li Z, Zhao X, Zuo X, Peng Z. miR-10b promotes invasion by targeting HOXD10 in colorectal cancer. *Oncol Lett.* 2016;12(1):488-494.
115. Xiao H, Li H, Yu G, et al. MicroRNA-10b promotes migration and invasion through KLF4 and HOXD10 in human bladder cancer. *Oncol Rep.* 2014;31(4):1832-1838.
116. Xue M, Fang Y, Sun G, et al. IGFBP3, a transcriptional target of homeobox D10, is correlated with the prognosis of gastric cancer. *PLoS One.* 2013;8(12):e81423.
117. Yachi K, Tsuda M, Kohsaka S, et al. miR-23a promotes invasion of glioblastoma via HOXD10-regulated glial-mesenchymal transition. *Signal Transduct Target Ther.* 2018;3:33.
118. Yang H, Zhou J, Mi J, et al. HOXD10 acts as a tumor-suppressive factor via inhibition of the RHOC/AKT/MAPK pathway in human cholangiocellular carcinoma. *Oncol Rep.* 2015;34(4):1681-1691.
119. Yuan YH, Wang HY, Lai Y, et al. Epigenetic inactivation of HOXD10 is associated with human colon cancer via inhibiting the RHOC/AKT/MAPK signaling pathway. *Cell Commun Signal.* 2019;17(1):9.
120. Zhang J, Liu S, Zhang D, Ma Z, Sun L. Homeobox D10, a tumor suppressor, inhibits the proliferation and migration of esophageal squamous cell carcinoma. *J Cell Biochem.* 2019;120(8):13717-13725.
121. Zhou Y, Wang C, Liu X, Wu C, Yin H. Long non-coding RNA HOTAIR enhances radioresistance in MDA-MB231 breast cancer cells. *Oncol Lett.* 2017;13(3):1143-1148.
122. Kim SD, Park RY, Kim YR, et al. HOXB13 is co-localized with androgen receptor to suppress androgen-stimulated prostate-specific antigen expression. *Anat Cell Biol.* 2010;43(4):284-293.
123. Brechka H, Bhanvadia RR, VanOpstall C, Vander Griend DJ. HOXB13 mutations and binding partners in prostate development and cancer: function, clinical significance, and future directions. *Genes Dis.* 2017;4(2):75-87.
124. Hakami F, Darda L, Stafford P, Woll P, Lambert DW, Hunter KD. The roles of HOXD10 in the development and progression of head and neck squamous cell carcinoma (HNSCC). *Br J Cancer.* 2014;111(4):807-816.
125. Luo J, Wang Z, Huang J, et al. HOXC13 promotes proliferation of esophageal squamous cell carcinoma via repressing transcription of CASP3. *Cancer Sci.* 2018;109(2):317-329.
126. Cui Y, Zhang C, Li Y, Ma S, Cao W, Guan F. HOXD1 functions as a novel tumor suppressor in kidney renal clear cell carcinoma. *Cell Biol Int.* 2021;45(6):1246-1259.
127. Duan R, Han L, Wang Q, et al. HOXA13 is a potential GBM diagnostic marker and promotes glioma invasion by activating the Wnt and TGF-beta pathways. *Oncotarget.* 2015;6(29):27778-27793.
128. Gu Y, Gu J, Shen K, et al. HOXA13 promotes colon cancer progression through beta-catenin-dependent WNT pathway. *Exp Cell Res.* 2020;395(2):112238.
129. Hong CS, Jeong O, Piao Z, et al. HOXB5 induces invasion and migration through direct transcriptional up-regulation of beta-catenin in human gastric carcinoma. *Biochem J.* 2015;472(3):393-403.
130. Kwon OS, Oh E, Park JR, et al. GalNAc-T14 promotes metastasis through Wnt dependent HOXB9 expression in lung adenocarcinoma. *Oncotarget.* 2015;6(39):41916-41928.
131. Lee K, Chang JW, Oh C, et al. HOXB5 acts as an oncogenic driver in head and neck squamous cell carcinoma via EGFR/Akt/Wnt/beta-catenin signaling axis. *Eur J Surg Oncol.* 2020;46(6):1066-1073.
132. Nguyen DX, Chiang AC, Zhang XH, et al. WNT/TCF signaling through LEF1 and HOXB9 mediates lung adenocarcinoma metastasis. *Cell.* 2009;138(1):51-62.
133. Qi L, Chen J, Zhou B, et al. HomeoboxC6 promotes metastasis by orchestrating the DKK1/Wnt/beta-catenin axis in right-sided colon cancer. *Cell Death Dis.* 2021;12(4):337.
134. Tan X, Jiang L, Wu X, Feng W, Lin Q. MicroRNA-625 inhibits the progression of nonsmall cell lung cancer by directly targeting HOXB5 and deactivating the Wnt/beta-catenin pathway. *Int J Mol Med.* 2019;44(1):346-356.
135. Wang L, Cui Y, Sheng J, et al. Epigenetic inactivation of HOXA11, a novel functional tumor suppressor for renal cell carcinoma, is associated with RCC TNM classification. *Oncotarget.* 2017;8(13):21861-21870.
136. Xiong H, Xiao H, Luo C, et al. GRP78 activates the Wnt/HOXB9 pathway to promote invasion and metastasis of hepatocellular carcinoma by chaperoning LRP6. *Exp Cell Res.* 2019;383(1):111493.
137. Yu H, Neale G, Zhang H, et al. Downregulation of Prdm16 mRNA is a specific antileukemic mechanism during HOXB4-mediated HSC expansion in vivo. *Blood.* 2014;124(11):1737-1747.
138. Zhang B, Li N, Zhang H. Knockdown of homeobox B5 (HOXB5) inhibits cell proliferation, migration, and invasion in non-small cell lung cancer cells through inactivation of the Wnt/beta-catenin pathway. *Oncol Res.* 2018;26(1):37-44.
139. Zhang L, Wu Q, He C, et al. HOXB9 inhibits proliferation in gastric carcinoma cells via suppression of phosphorylated-Akt and NF-kappaB-dependent snail expression. *Dig Liver Dis.* 2019;51(1):157-165.
140. Zhang Y, Zhang Q, Cao Z, Huang Y, Cheng S, Pang D. HOXD3 plays a critical role in breast cancer stemness and drug resistance. *Cell Physiol Biochem.* 2018;46(4):1737-1747.
141. Chen SW, Zhang Q, Xu ZF, et al. HOXC6 promotes gastric cancer cell invasion by upregulating the expression of MMP9. *Mol Med Rep.* 2016;14(4):3261-3268.
142. Cheng L, Wei X, Zhao K, et al. The predictive potential and oncogenic effects of HOXC8 expression on osteosarcoma. *Tumour Biol.* 2016;37(11):14961-14967.
143. Cui XP, Qin CK, Zhang ZH, et al. HOXA10 promotes cell invasion and MMP-3 expression via TGFbeta2-mediated activation of the p38 MAPK pathway in pancreatic cancer cells. *Dig Dis Sci.* 2014;59(7):1442-1451.
144. Kim M, Suh DH, Choi JY, et al. Mutually exclusive antiproliferative effect of cell line-specific HOX inhibition in epithelial ovarian cancer cell lines: SKOV-3 vs RMUG-S. *J Cell Mol Med.* 2020;24(5):3246-3251.
145. Zheng H, Li C, Li Z, et al. HOXB9 enhances the ability of lung cancer cells to penetrate the blood-brain barrier. *Aging (Albany NY).* 2020;12:4999-5019.
146. Zhuang L, Li WH, Li K, Mao Y, Gao CL, Zhang C. HoxB7 promotes growth and metastasis of lung adenocarcinoma cells through regulation of the TGF-beta/SMAD3 signaling. *J Biol Regul Homeost Agents.* 2015;29(3):601-608.
147. Feng W, Huang W, Chen J, et al. CXCL12-mediated HOXB5 overexpression facilitates colorectal cancer metastasis through transactivating CXCR4 and ITGB3. *Theranostics.* 2021;11(6):2612-2633.
148. Hamada J, Omatsu T, Okada F, et al. Overexpression of homeobox gene HOXD3 induces coordinate expression of metastasis-related genes in human lung cancer cells. *Int J Cancer.* 2001;93(4):516-525.
149. Klausen C, Leung PC, Auersperg N. Cell motility and spreading are suppressed by HOXA4 in ovarian cancer cells: possible involvement of beta1 integrin. *Mol Cancer Res.* 2009;7(9):1425-1437.

150. Liao SJ, Zhou YH, Yuan Y, et al. Triggering of toll-like receptor 4 on metastatic breast cancer cells promotes alphavbeta3-mediated adhesion and invasive migration. *Breast Cancer Res Treat.* 2012; 133(3):853-863.
151. Luo BP, Luo J, Hu YB, Yao XW, Wu FH. Cyclin D1b splice variant promotes alphavbeta3-mediated EMT induced by LPS in breast cancer cells. *Curr Med Sci.* 2018;38(3):467-472.
152. Ohta H, Hamada J, Tada M, et al. HOXD3-overexpression increases integrin alpha v beta 3 expression and deprives E-cadherin while it enhances cell motility in A549 cells. *Clin Exp Metastasis.* 2006; 23(7-8):381-390.
153. Zhan J, Niu M, Wang P, et al. Elevated HOXB9 expression promotes differentiation and predicts a favourable outcome in colon adenocarcinoma patients. *Br J Cancer.* 2014;111(5):883-893.
154. Zhang J, Yang M, Li D, et al. Homeobox C8 is a transcriptional repressor of E-cadherin gene expression in non-small cell lung cancer. *Int J Biochem Cell Biol.* 2019;114:105557.
155. Taniguchi Y, Tanaka O, Sekiguchi M, et al. Enforced expression of the transcription factor HOXD3 under the control of the Wnt1 regulatory element modulates cell adhesion properties in the developing mouse neural tube. *J Anat.* 2011;219(5):589-600.
156. Song C, Han Y, Luo H, et al. HOXA10 induces BCL2 expression, inhibits apoptosis, and promotes cell proliferation in gastric cancer. *Cancer Med.* 2019;8(12):5651-5661.
157. Moon SM, Kim SA, Yoon JH, Ahn SG. HOXC6 is deregulated in human head and neck squamous cell carcinoma and modulates Bcl-2 expression. *J Biol Chem.* 2012;287(42):35678-35688.
158. Qu LP, Zhong YM, Zheng Z, Zhao RX. CDH17 is a downstream effector of HOXA13 in modulating the Wnt/beta-catenin signaling pathway in gastric cancer. *Eur Rev Med Pharmacol Sci.* 2017;21(6): 1234-1241.
159. Gao Y, Fei X, Kong L, Tan X. HOXB5 promotes proliferation, migration, and invasion of pancreatic cancer cell through the activation of the GSK3beta/beta-catenin pathway. *Anticancer Drugs.* 2020;31(8): 828-835.
160. Lee JY, Hur H, Yun HJ, et al. HOXB5 promotes the proliferation and invasion of breast cancer cells. *Int J Biol Sci.* 2015;11(6):701-711.
161. Wang L, Tong D, Guo Q, et al. HOXD3 targeted by miR-203a suppresses cell metastasis and angiogenesis through VEGFR in human hepatocellular carcinoma cells. *Sci Rep.* 2018;8(1):2431.
162. Jacobs JF, Idema AJ, Bol KF, et al. Regulatory T cells and the PD-L1/PD-1 pathway mediate immune suppression in malignant human brain tumors. *Neuro Oncol.* 2009;11(4):394-402.
163. Adams S, Teo C, McDonald KL, et al. Involvement of the kynurenine pathway in human glioma pathophysiology. *PLoS One.* 2014;9(11): e112945.
164. Morgan R, El-Tanani M, Hunter KD, Harrington KJ, Pandha HS. Targeting HOX/PBX dimers in cancer. *Oncotarget.* 2017;8:32322-32331.
165. Kelly Z, Moller-Levet C, McGrath S, et al. The prognostic significance of specific HOX gene expression patterns in ovarian cancer. *Int J Cancer.* 2016;139(7):1608-1617.
166. Shen LY, Zhou T, Du YB, Shi Q, Chen KN. Targeting HOX/PBX dimer formation as a potential therapeutic option in esophageal squamous cell carcinoma. *Cancer Sci.* 2019;110(5):1735-1745.
167. Ando H, Natsume A, Senga T, et al. Peptide-based inhibition of the HOXA9/PBX interaction retards the growth of human meningioma. *Cancer Chemother Pharmacol.* 2014;73(1):53-60.
168. Errico MC, Felicetti F, Bottero L, et al. The abrogation of the HOXB7/PBX2 complex induces apoptosis in melanoma through the miR-221&222-c-FOS pathway. *Int J Cancer.* 2013;133(4):879-892.
169. Morgan R, Pirard PM, Shears L, Sohal J, Pettengell R, Pandha HS. Antagonism of HOX/PBX dimer formation blocks the in vivo proliferation of melanoma. *Cancer Res.* 2007;67(12):5806-5813.
170. Alharbi RA, Pandha HS, Simpson GR, et al. Inhibition of HOX/PBX dimer formation leads to necroptosis in acute myeloid leukemia cells. *Oncotarget.* 2017;8(52):89566-89579.
171. Kettyle LM, Liberante FG, Thompson A. Rational drug repurposing using sscMap analysis in a HOX-TALE model of leukemia. *Methods Mol Biol.* 2014;1196:349-370.
172. Tunyasuvunakool K, Adler J, Wu Z, et al. Highly accurate protein structure prediction for the human proteome. *Nature.* 2021;596: 590-596.
173. Watt GF, Scott-Stevens P, Gaohua L. Targeted protein degradation in vivo with proteolysis targeting chimeras: current status and future considerations. *Drug Discov Today Technol.* 2019;31:69-80.

How to cite this article: Morgan R, Hunter K, Pandha HS. Downstream of the HOX genes: Explaining conflicting tumour suppressor and oncogenic functions in cancer. *Int. J. Cancer.* 2022;1-14. doi:10.1002/ijc.33949