



Deposited via The University of Sheffield.

White Rose Research Online URL for this paper:

<https://eprints.whiterose.ac.uk/id/eprint/177467/>

Version: Accepted Version

---

**Article:**

Long, T., Ozger, M., Cetinkaya, O. et al. (2018) Energy neutral internet of drones. IEEE Communications Magazine, 56 (1). pp. 22-28. ISSN: 0163-6804

<https://doi.org/10.1109/mcom.2017.1700454>

---

© 2018 IEEE. Personal use of this material is permitted. Permission from IEEE must be obtained for all other users, including reprinting/ republishing this material for advertising or promotional purposes, creating new collective works for resale or redistribution to servers or lists, or reuse of any copyrighted components of this work in other works. Reproduced in accordance with the publisher's self-archiving policy.

**Reuse**

Items deposited in White Rose Research Online are protected by copyright, with all rights reserved unless indicated otherwise. They may be downloaded and/or printed for private study, or other acts as permitted by national copyright laws. The publisher or other rights holders may allow further reproduction and re-use of the full text version. This is indicated by the licence information on the White Rose Research Online record for the item.

**Takedown**

If you consider content in White Rose Research Online to be in breach of UK law, please notify us by emailing [eprints@whiterose.ac.uk](mailto:eprints@whiterose.ac.uk) including the URL of the record and the reason for the withdrawal request.

# Energy Neutral Internet of Drones

Teng Long, *Member, IEEE*, Mustafa Ozger, *Student Member, IEEE*,  
Oktay Cetinkaya, *Student Member, IEEE*, Ozgur B. Akan, *Fellow, IEEE*

**Abstract**—Extensive use of amateur drones (ADrs) poses threat to the public safety for their possible misuse. Hence, surveillance drones (SDrs) are utilized to detect and eliminate potential threats. However, limited battery, and lack of efficient communication and networking solutions degrade the quality of surveillance. To this end, we conceptualize Energy Neutral Internet of Drones (*enIoD*) to enable enhanced connectivity between drones by overcoming energy limitations for autonomous and continuous operation. Power provisioning with recharging stations is introduced by wireless power transfer (WPT) to energize the drones. Renewable energy harvesting (EH) is utilized to realize energy neutrality, which is minimization of deficit in harvested and consumed energy in *enIoD*. Communication and networking architectures and protocols for realization of multi-dimensional objectives are presented. Finally, possible application areas are explained with a case study to show how *enIoD* operates.

**Index Terms**—Internet of Drones, Drone Surveillance, Wireless Power Transfer, Energy Harvesting, Energy Neutrality.

## I. INTRODUCTION

USAGE of drones, also known as unmanned aerial vehicles (UAVs), is expected to rise at unprecedented rates owing to growing interest from researchers, hobbyist and investors. The use of free sky without constraints from physical roads offers drones superior abilities over their ground alternatives due to their great potentials in applications such as surveillance, logistics, and signal coverage.

Their utilization poses important threats to public safety since they can be used to carry explosives and agents to attack people, governmental and historical sites. Hence, the surveillance of this type of drones is very important to avoid such attacks beforehand. Amateur drone (ADr) surveillance solutions require deployment of surveillance drones (SDrs) to jam or hunt the ADr.

For reliable and efficient surveillance over an area by SDrs, they need to communicate in a seamless manner to target and track the ADr. Internet of Drones (IoD) [1] can be utilized in this type of surveillance applications due to its Internet connectivity. Each drone can be accessible via the Internet to target ADr drones and operate in a collaborative manner. However, they pose challenges such as highly dynamic flight routes due to their 3-dimensional (3D) movement, intermittent

connectivity, and dynamic geography. Furthermore, their limited on-board energy storage restricts flight time. Since ADr may attack at any time, continuous surveillance of ADr is vital.

To overcome these challenges for surveillance of ADr, we introduce a new networking paradigm, i.e., *Energy Neutral Internet of Drones (enIoD)*. In this paradigm, deployment of Energy Harvesting (EH) capable recharging stations on ground gives SDrs ability to recharge their batteries via Wireless Power Transfer (WPT), which increases their flight time and provides autonomous operation. Consecutive energy provision during the flight can address this issue. The recharging should be fast and autonomous without necessity of human intervention. The key feature of *enIoD* is minimization of deficit between gained energy by EH and consumed energy by SDrs in principle. The main instrument to realize energy neutrality is EH from renewable resources. Furthermore, we envision that special drones, i.e., master/backbone drones, can harvest energy and have the ability to carry energy, data and packet due to their multi-modality objective space. The Internet connectivity of drones may be via direct communication with recharging stations, via multiple hops through drones to access the ground stations or via satellite links as shown in Fig. 1 depending on communication architecture.

*enIoD* enables continuous and autonomous operation with extended lifetime. Hence, they can be efficiently utilized in intruder detection, localization, tracking and jamming of ADr. The paper is organized as follows. Section II outlines the power provisioning for *enIoD*. Section III investigates physical and link layers, and networking of the SDrs to support multi-dimensional objective of *enIoD*. Possible applications with a case study are explained in Section IV. Finally, the paper is concluded.

## II. POWER PROVISIONING FOR ENERGY NEUTRAL INTERNET OF DRONES

### A. Barrier of Energy Storage On-board

Conventional drive-trains use Internal Combustion Engines (ICEs) to rotate propellers by burning fossil fuels (normally petrol) stored in the fuel tank. Compared to electrically powered drones, ICEs have higher operating costs, higher noise, higher vibration, emissions and slower control dynamics. Although higher energy density of petrol overcomes lower efficiency of ICEs to offer longer flight time, refueling petrol requires human intervention so the autonomy of operation is limited. Electrical drive-trains are advantageous because electric motors exhibit higher power density, simple structure, zero-emission and lower operation cost. However, low gravitational energy density of batteries (Wh/kg) remains the major challenge for electrically-powered drones.

T. Long is with Internet of Everything (IoE) Group and Electronics, Power and Energy Conversion (EPEC) Group, Electrical Engineering Division, Department of Engineering, University of Cambridge, CB3 0FA Cambridge, UK (e-mail: TL322@cam.ac.uk).

M. Ozger and O. Cetinkaya are with Next-generation and Wireless Communications Laboratory (NWCL), Department of Electrical and Electronics Engineering, Koc University, Istanbul, 34450, Turkey (e-mail: {mozger, okcetinkaya13}@ku.edu.tr).

Ozgur B. Akan is with Internet of Everything (IoE) Group, Electrical Engineering Division, Department of Engineering, University of Cambridge, CB3 0FA Cambridge, UK (e-mail: OBA21@cam.ac.uk).

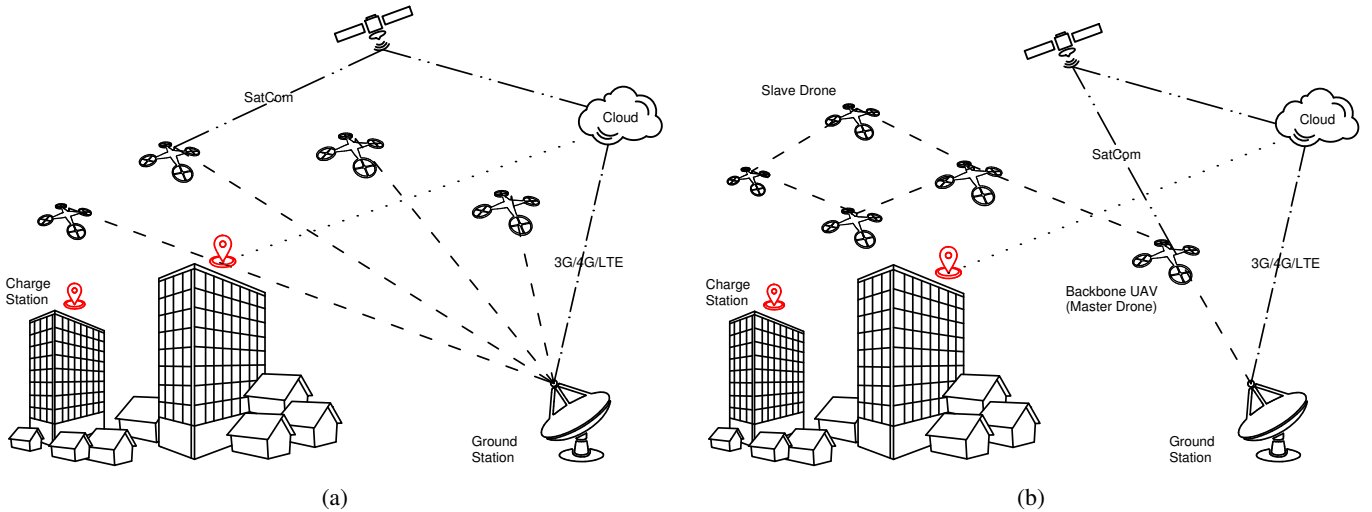

Fig. 1: (a) Centralized *enIoD* network architecture; (b) Distributed *enIoD* network architecture.

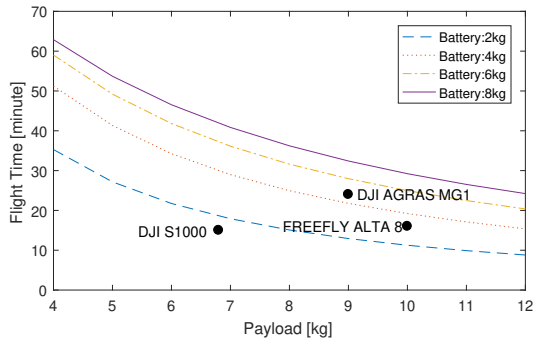

Fig. 2: Relation between payload and flight time. Equivalent rotor diameter: 3 m, LiPo battery with 220 Wh/kg energy density, drone weight (excluding battery): 5 kg.

Lithium-ion-polymer (LiPo) technology has been commonly used as on-board batteries offering up to 220 Wh/kg energy density, only 2% of petrol. The relation between the payload and flight time under different size of LiPo batteries can be derived by applying aerodynamic analysis as illustrated in Fig. 2. Some commercially available heavy lifting drones, shown in Table I, indicate that no electrically powered drones is capable of flying more than 30 minutes with no less than 4 kilogram payload.

TABLE I: Selected heavy lifting commercial drones.

	DJI AGRAS MG-1	FREEFLY ALTA 8	DJI S1000
<b>Max Payload</b>	9 kg	10 kg	6.8 kg
<b>Flight Time</b>	24 min	16 min	15 min
<b>Battery Capacity</b>	533 Wh	444 Wh	222 Wh
<b>Weight (ex. battery)</b>	8.8 kg	6.2 kg	4.4 kg

Without foreseeable revolutionary breakthroughs of batteries, automatic battery charging is a feasible approach to increase the flight time without compromising the payload [2]. A refueling scheme to accommodate a number of SDRs at the same time without human intervention is proposed in this article, which is essential for enabling the concept of *enIoD*.

### B. WPT-based Opportunity Charging for SDRs

Opportunity charging (OC) concept has been raised to extend the range of electric vehicles (EVs) with reduced on-board energy storage and dwell time of charging. To date, public transportation such as buses has pioneered OC schemes due to their fixed routes. Demonstration projects have been reported worldwide and outcomes have illustrated benefits [3].

However, the physical roads limit the potential of OC due to accession to the recharging points. As shown in Fig. 3(a), from point S to T, only recharging point A can be adopted as no road to access, resulting in a waste of charging opportunity. The drone, by contrast, does not need physical roads to facilitate their movement so the route of each drone can be adjusted freely and dynamically, as shown in Fig. 3(b). The adoption of recharging point is solely determined by the status of the on-board battery. As shown in Fig. 3(c) to (e), hub-based centralized network for ground EVs becomes a community-based distributed network with an exceptional increase in the number of routes for drones. The use of both horizontal and vertical space means a 3D arrangement of recharging locations for drones, offering more flexibilities and higher transportation density. Thus, the advantage of using the free sky offers a greatly enhanced OC scheme for SDRs to increase both the endurance and payload with flexible networking approaches.

### C. Design of WPT Systems for SDRs

The OC needs to be fast, reliable, efficient and unmanned to support *enIoD* concept. Both contact (wired) and contact-less (wireless) charging approaches can be used. For the contact approach, precise landing of drones is mandatory for making contact of terminals, requiring complex and expensive control and sensing systems. The exposure of electrical outlets for physical contact is prone to hazards and vulnerable to dusts, corrosion and mechanical vibrations. WPT without electrical plugging, by contrast, can overcome the aforementioned issues because of some tolerance to misalignment when charging and the galvanic isolation to the electrical outlets [4]. Although WPT systems used in automotive applications have been

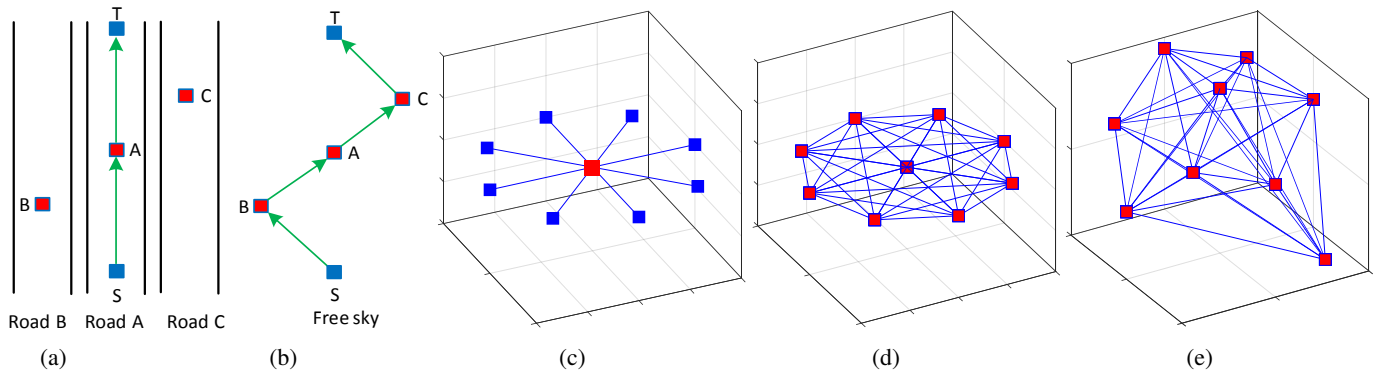

Fig. 3: (a) Limited charging opportunity on the ground; (b) Flexible charging opportunity in the sky; (c) Limited opportunity charging at 2D; (d) Flexible charging opportunity at 2D; (e) Flexible charging opportunity at 3D.

intensively investigated in recent years [5], OC for drones exhibits different characteristics and requirements. In this article, holistic design paradigm of WPT for drones is proposed to conceptualize the idea and call for future validation. We selectively present some key characteristics of the system, highlight research challenges and aspire to stimulate research and development of such technologies.

The inductive power transfer (IPT) method can be selected for WPT. The system comprises an on-land transmitter and an on-board receiver. The alternating magnetic flux generated by the transmitter is picked up by the receiver through the air gap between the transmitter and receiver. Recent progress on electromagnetic coil (EMC) design has improved coupling between two coils at each side. As shown in Fig. 4(a) to (d), polarized single-sided time-varying flux needs to alternating between two coils at high frequency (80-to-100kHz) to achieve high efficiency of WPT [6]. The geometry and structure of the winding and core in the coil need to be specially designed to have tolerance to misalignment at both the lateral and horizontal directions, offering easiness of landing for recharging.

IPT systems at radio frequency (RF) have been commercialized for charging consumer electronics (less than 10W). The advantage of RF IPT is the increased distance for power transfer so uninterrupted energy can be directly provided to ultra-lightweight drones by using IPT instead of using on-board batteries. It is also possible to concurrently transfer energy and communication signal to drones by using integrated receiver and transmitter, thus compactness and utilization of the system will be enhanced [7]. However, high frequency is not suitable for high power rating IPT for charging heavy lifting drones because of EMC and losses from power electronic circuits.

The air gap (distance) between the transmitter and receiver should be designed as small as possible to achieve high efficient WPT. For drones, the receiver coil can form the landing skid and directly attach to the transmitter coil when landing, reducing much of the air gap created by ground clearance required by ground vehicles as shown in Fig. 4(b), benefiting the efficiency of power transfer. The receiver coil in this arrangement must have a solid structure with high toughness and robustness to tolerate shock caused by landing, and the IPT receiver coil must be lightweight.

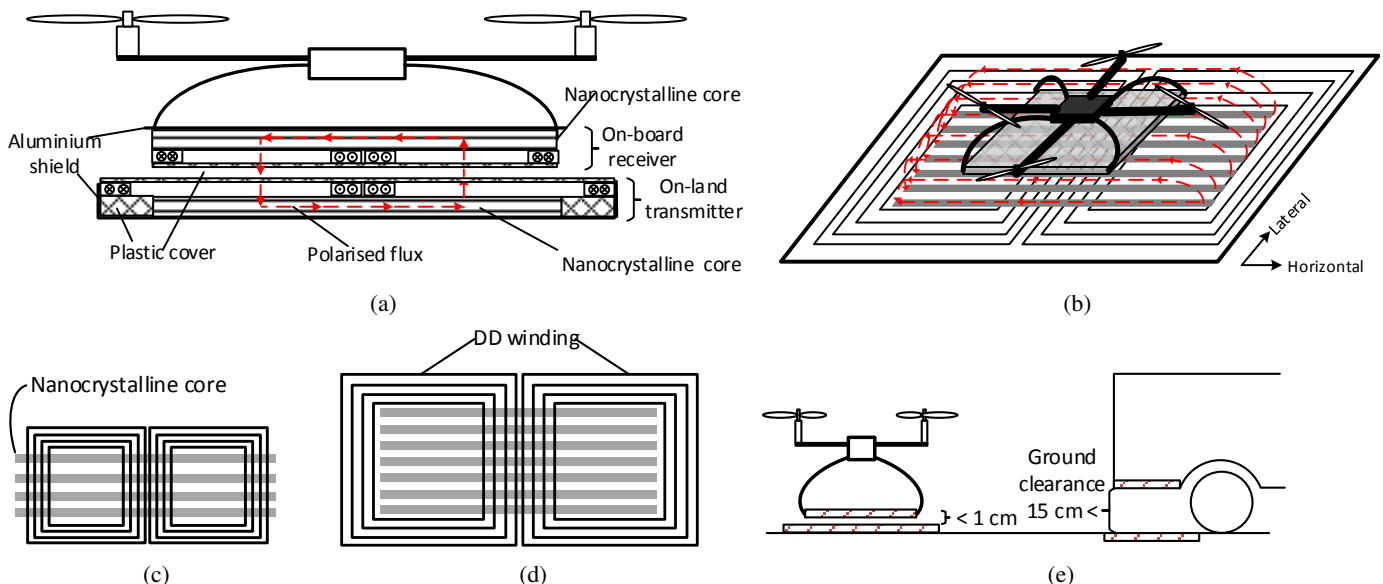

Fig. 4: (a) IPT couplers in drones; (b) Coupling between transmitter and receiver; (c) On board receiver coil; (d) On-land transmitter coil; (e) Air gap comparison between drones and cars.

Power electronic converters must be used in IPT systems to generate and receive high frequency magnetic fields. By virtue of high compactness and efficiency from increased switching frequencies and low operating losses, emerging wide band gap power semiconductors such as Silicon Carbide and Gallium Nitride suit for IPT applications for drones particularly at the on-board DC/AC and DC/DC converters [8]. Facilitated by state-of-the-art embedded controllers, control and modulation schemes need to be specifically designed to work with EMCs and compensation circuit to maintain high efficiency and power density at various alignment and loads. Due to high interdependency between power electronic circuit, compensation circuit, EMC and control schemes, multi-objective optimization design is required.

The use of local renewable energy and energy storage at the charging station can enable an energy neutral OC system for the IoD. Distributed small wind turbines and solar panels have power output range from 5-to-50 kW, which are suitable to energize multiple charging places at one station at one time because the charging rating for each drone is normally less than 3 kW. The capacity of on-board battery for drones should be less than 1 kWh due to the weight limit and energy density of batteries, and the desirable charging time should be controlled to couple of minutes. Current off-the-shelf domestic energy storages with a capacity range from 1-to-20 kWh can be employed at each charging station to accommodate the intermittent renewable energy output and buffer potential disturbance to the grid. A common DC bus can be used to interface power supplies, storage and charging loads with improved efficiency and controllability as shown in Fig. 5. It is worth noting that hardware used in integrating renewable energy into the charging station is technically mature thanks to recent progress in power electronics and renewable energy.

Misalignment and increasing power transfer rating are two main challenges for using IPT charging EVs; however, they are not hurdles for using IPT charging drones because of reduced air gap and more freedom of alignment. However, some new challenges will emerge, namely:

- The on-board IPT receiver is more sensitive to the weight

compared to EVs. The additional IPT receiver should not trade payload off but only sacrifice the capacity of the on-board battery. Investigation should be conducted on finding out the optimized allocation of weight between the battery and the IPT receiver. Faster charging comes from higher power rating of the IPT so high gravimetric power density as kW/kg is a critical design requirement of IPT receiver. The sacrificed battery needs to carry adequate energy for drones to maneuver between charging stations in the network and properly placed charging stations are critical to ensure continuous and autonomous operation.

- Ferrite as a ceramic compound has been commonly used for magnetic cores of most of current high power rating IPT coils. However, Ferrite cores are vulnerable to shock from landing due to its fragile structure. To address this issue, this article proposes the use of Nanocrystalline alloy instead of Ferrite for the cores which exhibits increased ductility than Ferrite. Additionally, Nanocrystalline alloy also shows higher permeability, higher flux density saturation and lower narrower hysteresis losses, making the coil a higher power density [9]. Progress in mass production of Nanocrystalline alloy in recent years also promises a continuous cost down.
- The magnetic field can present a hazard when an object is placed on the charging coil thus the system must have a reliable foreign-object identification approach to avoid incidental turning-on when an obstruction on the charging coil.

### III. COMMUNICATION IN ENERGY NEUTRAL INTERNET OF DRONES

*enIoD* is a highly dynamic network due to random nature of harvestable resources, minimization of energy gap between harvested and consumed energy for energy neutrality, 3D movement of drones, WPT-based OC, and multi-dimensional objective space of SDrs. Hence, we overview possible communication architectures, physical and link layers, and networking challenges and solutions for multi-dimensional objectives of *enIoD* with related open issues.

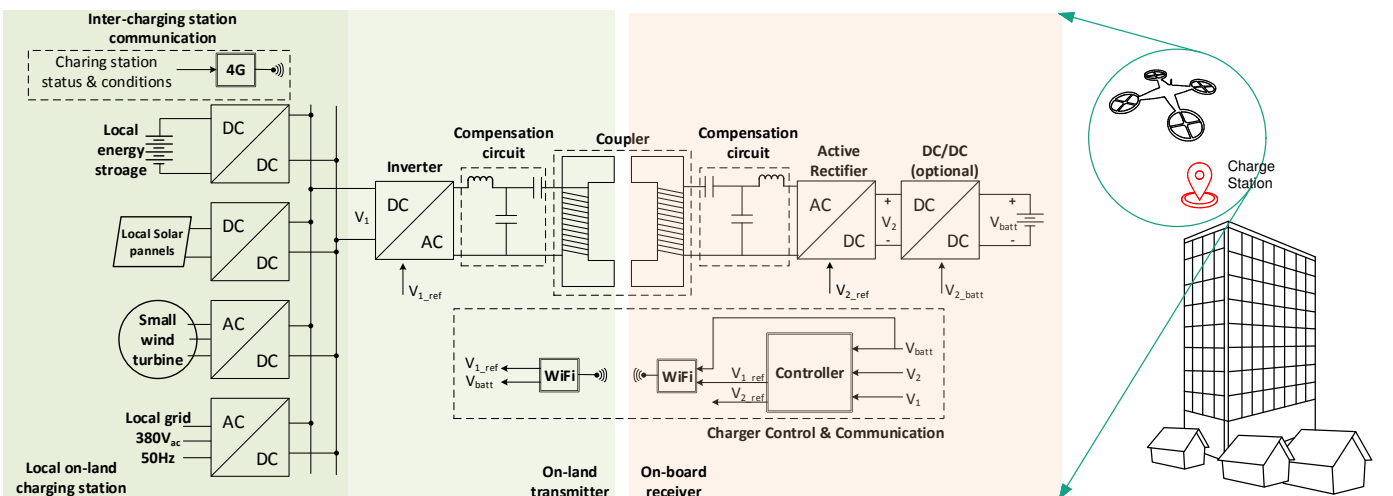

Fig. 5: Energy management of WPT systems used in *enIoD*.

### A. Communication Architectures of *enIoD*

SDrs may form a centralized or an ad-hoc network. In the centralized, the drones are controlled by ground/recharging stations or satellites without any direct communication between the drones as in Fig 1(a). In such a dynamic network, centralized communication architecture is not practical for *enIoD* since it imposes every message to traverse ground/recharging stations that causes inefficiency and delay.

As in Fig 1(b), communication among drones is performed in a distributed manner [10]. There are three types of ad-hoc networks, which are regular, multi-group and multilayer ad-hoc networks. In regular ad-hoc networks, the drones communicate among themselves without any infrastructure. In multi-group networks, some of the drones form an ad-hoc network in which the connection to the ground/recharging stations is provided via a backbone, i.e., master, drone. Multilayer network consists of multi-group networks. They connect via their backbone drones, which form an upper layer of the network on top of the ad-hoc network. They can be considered as cluster-heads in wireless ad-hoc networks.

Without any need for infrastructure, ad-hoc communication architecture is a better option for *enIoD*. However, adoption of ad-hoc architecture results in following issues:

- Hierarchical network architecture is more preferable than homogeneous one since more capable drones can regulate the communication between the drones.
- Ad-hoc networks may consist of master and slave drones, where master drones have EH capability and send energy to slave drones with WPT.
- Master drones may have direct Internet connection thanks to their modules and act as a gateway to the Internet for slave drones.
- Master-slave drone architecture results in highly dynamic association/disassociation procedures from clusters formed by master drones in *enIoD* due to high mobility.

### B. Physical and Link Layers in *enIoD*

There are two communication schemes in *enIoD*, which are the communication among the drones, and the communication between the drones and cloud services via the ground/recharging stations or satellites. Drone-to-drone (D2D) communication is modeled as a signal received by the receiver drone, which is dominated by the line-of-sight (LoS) component due to small effects of ground reflections [11]. However, due to the high mobility of SDrs, it experiences Doppler effect.

The other communication scheme is between the drones and the ground/recharging stations or satellites. It is important to send instructions to drones and to execute difficult tasks by cloud computing services on the ground. However, it may be distorted due to obstacles depending on the geographical properties of the operation region. The communication is modeled either as a two-ray model or a Ricean channel due to the dominant LoS component in the received signal. The drones may also communicate with the cloud services via satellites. The drone-to-satellite link is established when there is no coverage from the ground stations. However, it poses two challenges, which are limited bandwidth and costly data

transfer [12]. *enIoD* can be deployed in different regions especially in urban areas due to its extensive surveillance applications. Hence, physical layer solutions must consider inherent challenges and diverse application areas of *enIoD*.

The control of SDrs requires excessive signaling, hence access to the channel should be performed efficiently to avoid collisions and loose connectivity. The intermittent connectivity of the drones due to highly mobile network causes degradation in the Internet connection. The Internet access can be provided via direct communication link if the drone is close to ground/recharging station. Furthermore, master drones may be equipped with 3G/4G/LTE-capable communication modules. They divide the space into Internet-enabled zones for the other drones. According to the flight of the Internet-capable drones, the Internet connectivity of the slave drones fluctuates.

Another connection scheme for the Internet is over the satellite. In case of no cellular coverage over the operation region, the drones can communicate with the cloud services via the satellite communication (SatCom) link to access the Internet as in Fig. 1.

Highly mobile drones due to 3D movement and energy neutrality by EH yield numerous open research issues:

- A realistic 3D channel modeling must be studied. In urban areas, the blockages and intervention must be modeled especially for D2D communications.
- Energy-efficient D2D communication schemes must be designed. Since LoS component is dominant in this type of communication, the effects of the utilization of millimeter-wave and terahertz bands should be investigated to provide high data rate communications, which may be suitable for video surveillance.
- Power control mechanisms must be developed by considering the gained power by WPT since it affects the connectivity between SDrs.
- Physical layer solutions should consider harsh power constraints of SDrs. Hence, they should be extremely energy-efficient by decreasing energy consumption to foster energy neutrality.
- According to network architecture of the *enIoD*, new communication protocols for medium access and routing packets between SDrs must be proposed by considering the *enIoD* challenges.
- Simulation platforms must be developed to test the proposed physical layer solutions. These platforms must consider the unique constraints of the *enIoD*.

### C. Networking for Multi-dimensional Objectives of *enIoD*

*enIoD* has multi-dimensional objective space. They have missions such as flying through regions for physical packet delivery, sending data to the remote areas, and carrying energy from one end to another. These complex missions require effective networking solutions with consideration of *enIoD*-specific challenges such as energy neutrality and limited capabilities of SDrs. We will investigate these missions in terms of networking aspects in *enIoD*.

1) *Carrying physical packets*: The first objective is to carry physical packets in diverse ADr surveillance applications. To

this end, flight path determination is the main consideration since the most of on-board energy is consumed during flight. There are many constraints in determining the flight path. The most important one is the energy availability of the drones. In addition, the length of the path is highly crucial, which depends not only on Euclidian distance but also obstacles in the operating region such as buildings, hills and no-fly-zones.

If a drone does not have sufficient energy to complete its flight, it can change the path to stop-by a recharging station to obtain sufficient energy to reach its final destination. The scheduling at the recharging station and its energy level are also important for WPT during the flight determination. Hence, the flight determination is also affected by the possibility of reaching an available recharging station. Meanwhile, optimized placement of recharging stations can provide useful opportunities for drones but still keep the cost of infrastructure acceptable. An overall system design is required with consideration of future expansion.

Furthermore, depending on the application, flight time may be critical. For instance, a drone may have to fly to a location for delivering its package within a certain time interval. However, if the drone cannot complete its flight in time, it may offload its mission to an available drone on the path. A new flight is again determined according to the time constraint to fulfill the task. During the flight determination, the collision with other SDRs must be avoided. Hence, this constraint requires online information about the paths of other drones, which makes it a challenging operation due to its complexity. Hence, to fulfill the mission of carrying packets, efficient networking applications should be proposed to regulate the communication and flight determination of SDRs.

2) *Carrying energy*: The main constraint of *enIoD* is the energy neutrality, which is achieved by EH. Due to random nature of EH resources and dynamic energy consumption of drones, there may be fluctuations in the balance. However, *enIoD* has the ultimate goal to balance them in principle. Energy consumed by drones comes from harvested renewable energy resulting in zero energy consumption of conventional energy resources and zero emission. The harvested energy may be from the environment using solar energy, wind power, vibrations, etc. in a hybrid manner [13].

Master drones may be designed to be more capable and even with EH ability. They may also carry energy from one recharging station with higher energy to another with less energy. The WPT system also needs to be capable of bi-directional power transfer to enable drone-to-grid and D2D energy flow. Furthermore, recharging stations can be mobile and reach to the region with energy-hunger drones. These features of *enIoD* require novel networking schemes for optimal placement of recharging stations to enable energy neutrality.

3) *Carrying information*: This objective is to fulfill overall surveillance mission of SDRs with jointly optimizing the gathered data in the cloud for machine learning and data mining. Hence, the drones send their data to the Internet for processing and taking action for the ADr surveillance. However, apart from powering flight, sensing and data delivery also consume considerable amount of energy because of additional demands on control, communication and computing.

Sensed data (e.g., high quality image or video) needs to be effectively processed to increase the quality of surveillance. However, typical drones with limited storage and processing capabilities beside battery constraints cannot cope with high energy requiring computation overhead. An SDR simply relays its data to the cloud services via the Internet, which reduces the energy consumption and processing time more than 100 times compared to on-board calculations [14]. The SDR can carry information by flying to a gateway drone or a ground station to access the Internet. It may also relay its data via multi-hopping through intermediate drones. This requires efficient routing algorithms.

Realization of multi-modality objectives of *enIoD* yields many open research issues:

- A registration protocol for drones and recharging stations needs to be designed for increasing the compatibility of using drones and charging stations from different ownerships. An intelligent control mechanism needs to be designed to dynamically operate a number of drones and recharging stations, and synchronize the transportation and energy flow in the system. Emergency control strategies to cope with faults and natural disasters need to be included to improve reliability and resiliency.
- To overcome the limited energy challenge and to foster the energy neutrality, efficient flight determination algorithms must be proposed since most of the energy is consumed during the flight.
- Hybrid EH schemes must be developed to increase the harvested energy at the recharging stations and to support energy neutrality. It will also contribute to continuity of EH as different EH techniques are combined.
- During the flight of SDRs, the number of available Internet-enabled drone may change. Hence, handover mechanisms must be developed to track the changes in members of the master drones.
- With the goal of autonomous and continuous operation of SDRs, new routing management and traffic control arise in accordance with optimal placement of recharging stations.
- A reliable real-time networking solution is critical because information of each drone such as duty, position, on-board energy as well as on-land recharging stations' status such as availability and distance need to be dynamically exchanged among SDRs.
- Taking into account of the ability to recuperate energy from a nearby recharging station and the condition of that station, an intelligent control algorithm needs to assign and adjust the route of each drone in the network to ensure reliable and efficient operation.

#### IV. POSSIBLE APPLICATIONS AND A CASE STUDY

Thanks to versatility and high mobility of drones, they are extensively used in diverse domains to provide outperforming solutions in civilian, commercial and governmental services. Air, land and water quality, wildlife, forest and agricultural fields monitoring, disaster relief, search/rescue operations and surveillance are some of leading drone applications [15].

Drones serve the purpose of homeland security such as patrolling borders for trespassing, drug and/or weapon smuggling, and terrorist infiltrations. They are also pervasively used in crowd surveillance during protests, sports events, parades, and concerts to recognize criminals, and detect malicious acts.

As a result of rapid development of ADr technology, they have become easily accessible. However, some ADRs may have harmful intentions. In order to cope with potential threats posed by ADRs, SDR utilization becomes important for surveillance, hunting and jamming of intruder ADRs. SDRs can detect, track and localize the malicious ADRs to take preclusive reactions and/or combat with them to reduce the number of casualties. Hence, SDRs offer huge potential to shorten reaction time, eliminate human-factor, and reduce the number of security staff employed to reconnaissance of ADRs. However, the current drone systems lack of autonomous and intervention-free operation. Hence, *enIoD* stands as a perfect candidate for ADR surveillance applications.

The most notable drawbacks of SDRs are energy storage, computation and connectivity constraints. Mostly due to small form and cost factors, SDRs do not have high-power condensed batteries and high processing capable processors. Among all constraints, energy bottleneck can be placed on the top. The flight time of the SDRs is highly limited due to their incapable batteries. Extension of the energy budget is therefore becomes crucial to better support ADR surveillance applications.

In an ADR surveillance case study, *enIoD* may consist of master and slave (MD/SD) drones operating in a hierarchy. When an SD has enough energy, it flies freely and performs its task without any intervention. However, if the energy level of it decreases below a predetermined threshold, an MD (e.g., recharging drone), the most convenient one in terms of distance to the SD of interest and on-board energy, tries to engage the low-battery SD to replenish its batteries. The MD is expected to enable precise SD landing by using certain technologies like GPS tracking and image processing. Once connected, the MD starts transferring energy, which is gathered by EH, to the SD with WPT. During WPT, the MD moves along the SD's track. In other words, the SD continues fulfilling its tasks while its batteries are being recharged by the MD, which resolves SD failures. Furthermore, as the time consumed on recharging is eliminated, potential data losses due to recharge process is also prevented. This architecture offers uninterrupted operation for mission-critical ADR surveillance thanks to EH and WPT.

In another approach, the operation time of the *enIoD* is extended by enabling the drones to receive energy from recharging stations deployed on buildings. Multiple recharging stations in the network form an OC scheme for drones to have consecutive provision of energy. An intelligent routing algorithm equipped with low energy consuming communication and computing devices is used to achieve maximum utilization of recharging stations, extension of flight time and reduced cost of infrastructure. These fixed stations extract energy from multiple sources, and replenish drone batteries by transferring the harvested energy via WPT. In some cases, a drone may land on an energy-rich station, wirelessly receive power and convey this energy to an energy-poor station to

keep the network alive.

*enIoD* actively inspects the area of interest, relays the acquired data, and rapidly actuates against ADRs. Hence, the discussed approaches have great importance to extensively contribute today's drone-assisted services, and to considerably change the operation of existing surveillance applications in the very near future.

## V. CONCLUSION

The use of drones shows great potentials in ADRs surveillance, but the challenges in energy provision, connectivity and operation need to be overcome to use SDRs at a large scale. In this article, *enIoD* is conceptualized to autonomously operate a large number of drones without concerns of aforementioned issues. A WPT-based OC scheme is proposed to offer extension of flight range by providing energy from EH to the drones. The energy used in the system is originally harvested from the renewable resources to minimize the gap between harvested and consumed energy in principle. Possible communication and networking solutions are presented to realize multi-dimensional objectives of *enIoD*. Aside from conceptualization of *enIoD*, this article also highlights open research challenges in this topic and aspires future research to validate the concept and technology.

## REFERENCES

- [1] M. Gharibi, R. Boutaba, and S. L. Waslander, "Internet of Drones," *IEEE Access*, vol. 4, pp. 1148-1162, Mar. 2016.
- [2] T. Campi, F. Dionisi, S. Cruciani, V. De Santis, M. Feliziani, and F. Maradei, "Magnetic field levels in drones equipped with Wireless Power Transfer technology," in *Proc. Asia-Pacific Int. Symp. Electromagn. Compat.*, vol. 1, pp. 544547, May 2016.
- [3] A. Brecher and D. Arthur, "Review and Evaluation of Wireless Power Transfer (WPT) for Electric Transit Applications," *FTA Rep. No. 0060, Fed. Transit Adm. U.S. Dep. Transp.*, no. 60, pp. 161, Aug. 2014.
- [4] S. Lukic and Z. Pantic, "Cutting the Cord: Static and Dynamic Inductive Wireless Charging of Electric Vehicles," *IEEE Electr. Mag.*, vol. 1, no. 1, pp. 57-64, Sep. 2013.
- [5] R. Bosshard and J. W. Kolar, "Inductive power transfer for electric vehicle charging: Technical challenges and tradeoffs," *IEEE Power Electron. Mag.*, vol. 3, no. 3, pp. 22-30, Sep. 2016.
- [6] G. A. Covic and J. T. Boys, "Inductive Power Transfer," in *Proc. IEEE*, vol. 101, no. 6, pp. 1276-1289, Jun. 2013.
- [7] R. G. Cid-Fuentes, M. Y. Naderi, S. Basagni, K. R. Chowdhury, A. Cabellos-Aparicio and E. Alarcon, "On signaling power: Communications over wireless energy," in *Proc. IEEE INFOCOM*, pp. 1-9, Apr. 2016.
- [8] R. Bosshard and J. W. Kolar, "Multi-Objective Optimization of 50 kW/85 kHz IPT System for Public Transport," *IEEE J. Emerg. Sel. Top. Power Electron.*, vol. 4, no. 4, pp. 1370-1382, Dec. 2016.
- [9] Wei Shen, Fei Wang, D. Boroyevich, and C. W. Tipton, "Loss Characterization and Calculation of Nanocrystalline Cores for High-Frequency Magnetics Applications," *IEEE Trans. Power Electron.*, vol. 23, no. 1, pp. 475-484, Jan. 2008.
- [10] J. Li, Y. Zhou, and L. Lamont, "Communication architectures and protocols for networking unmanned aerial vehicles," in *Proc. IEEE Globecom Workshops*, 2013, pp. 1415-1420.
- [11] Y. Zeng, R. Zhang, and T. J. Lim, "Wireless Communications with Unmanned Aerial Vehicles: Opportunities and Challenges," *IEEE Communications Magazine*, vol. 54, no. 5, pp. 36-42, May 2016.
- [12] H. Skinnemoen, "UAV & satellite communications live mission critical visual data," in *Proc. IEEE Int. Conf. Aerosp. Electron. Remote Sens. Technol. (ICARES)*, 2014, pp. 12-19.
- [13] O. B. Akan, O. Cetinkaya, C. Koca, and M. Ozger, "Internet of Hybrid Energy Harvesting Things," *IEEE Internet of Things Journal*, vol. 4, no. 6, Nov. 2017.
- [14] N. H. Motlagh, M. Bagaa, and T. Taleb, "UAV-Based IoT Platform: A Crowd Surveillance Use Case," *IEEE Communications Magazine*, vol. 55, no. 2, pp. 128-134, Feb. 2017.

- [15] N. H. Motlagh, T. Taleb, and O. Arouk, "Low-Altitude Aerial Vehicles-Based Internet of Things Services: Comprehensive Survey and Future Perspectives," *IEEE Internet of Things Journal*, vol. 3, no. 6, pp. 899-922, Dec. 2016

**Teng Long** (S'10-M'13) received the B.Eng degree from the Huazhong University and Science and Technology, China and B.Eng (1st Honor) degree from the University of Birmingham, UK, in 2009. He received his Ph.D degree in electrical engineering from the University of Cambridge, UK, in 2013. He is currently with the Electrical Engineering Division, Department of Engineering, University of Cambridge. His research interests include power electronics applications, wireless power transfer, DC power systems and electric vehicles.

**Mustafa Ozger** (S'12) received the BSc degree in electrical and electronics engineering from Middle East Technical University, Ankara, Turkey, in 2011, the MSc degree in electrical and electronics engineering from Koc University, Istanbul, Turkey, in 2013, and is currently working toward the PhD degree in the Electrical and Electronics Engineering Department, Koc University, Istanbul, Turkey. He is currently a research assistant in the Next-generation and Wireless Communication Laboratory. His current research interests include cognitive radio and sensor networks.

**Oktay Cetinkaya** (S'13) received his B.Sc. degree with double major in Electrical Engineering, and Electronics and Communication Engineering from Yildiz Technical University, Istanbul, Turkey, in June 2013 and January 2014, respectively. He is currently a research assistant at Next-generation and Wireless Communications Laboratory (NWCL) and pursuing his Ph.D. degree at the Electrical and Electronics Engineering Department, Koc University. His current research interests include energy harvesting communications in smart environments with advanced energy management, monitoring and control systems.

**Ozgur B. Akan** (M'00-SM'07-F'16) received his Ph.D. degree in electrical and computer engineering from the Broadband and Wireless Networking Laboratory, School of Electrical and Computer Engineering, Georgia Institute of Technology, Atlanta, GA, USA, in 2004. He is currently with the Electrical Engineering Division, Department of Engineering, University of Cambridge, UK. His research interests include wireless, nano, molecular communications, and Internet of everything.