

This is a repository copy of *Overview of the P2716~WG - IEEE Guide for the Characterization of the shielding effectiveness of printed circuit board level shielding : Single Reverb Room.*

White Rose Research Online URL for this paper:

<https://eprints.whiterose.ac.uk/176773/>

Proceedings Paper:

Dawson, John F orcid.org/0000-0003-4537-9977, Marvin, Andy C orcid.org/0000-0003-2590-5335 and She, Brian (Accepted: 2021) Overview of the P2716~WG - IEEE Guide for the Characterization of the shielding effectiveness of printed circuit board level shielding : Single Reverb Room. In: Proceedings of the 2021 Joint IEEE International Symposium on Electromagnetic Compatibility, Signal & Power Integrity and EMC Europe. 2021 Joint IEEE International Symposium on Electromagnetic Compatibility, Signal & Power Integrity and EMC Europe, 26 Jul - 20 Aug 2021 IEEE . (In Press)

Reuse

This article is distributed under the terms of the Creative Commons Attribution-ShareAlike (CC BY-SA) licence. This licence allows you to remix, tweak, and build upon the work even for commercial purposes, as long as you credit the authors and license your new creations under the identical terms. All new works based on this article must carry the same licence, so any derivatives will also allow commercial use. More information and the full terms of the licence here: <https://creativecommons.org/licenses/>

Takedown

If you consider content in White Rose Research Online to be in breach of UK law, please notify us by emailing eprints@whiterose.ac.uk including the URL of the record and the reason for the withdrawal request.



2021 JOINT IEEE INTERNATIONAL SYMPOSIUM
ON ELECTROMAGNETIC COMPATIBILITY,
SIGNAL & POWER INTEGRITY & EMC EUROPE

www.emc2021.org • #IEEE_ESP21



IEEE STANDARDS ASSOCIATION

IEEE P2716: IEEE Guide for the characterization of the effectiveness of printed circuit board level shielding



Single Reverb Room

John Dawson, Andy Marvin (University of York) and Brian She (Laird)



2021 JOINT IEEE INTERNATIONAL SYMPOSIUM ON ELECTROMAGNETIC COMPATIBILITY, SIGNAL & POWER INTEGRITY & EMC EUROPE

www.emc2021.org



[#IEEE_ESP21](https://twitter.com/IEEE_ESP21)



Laird Measurement setup

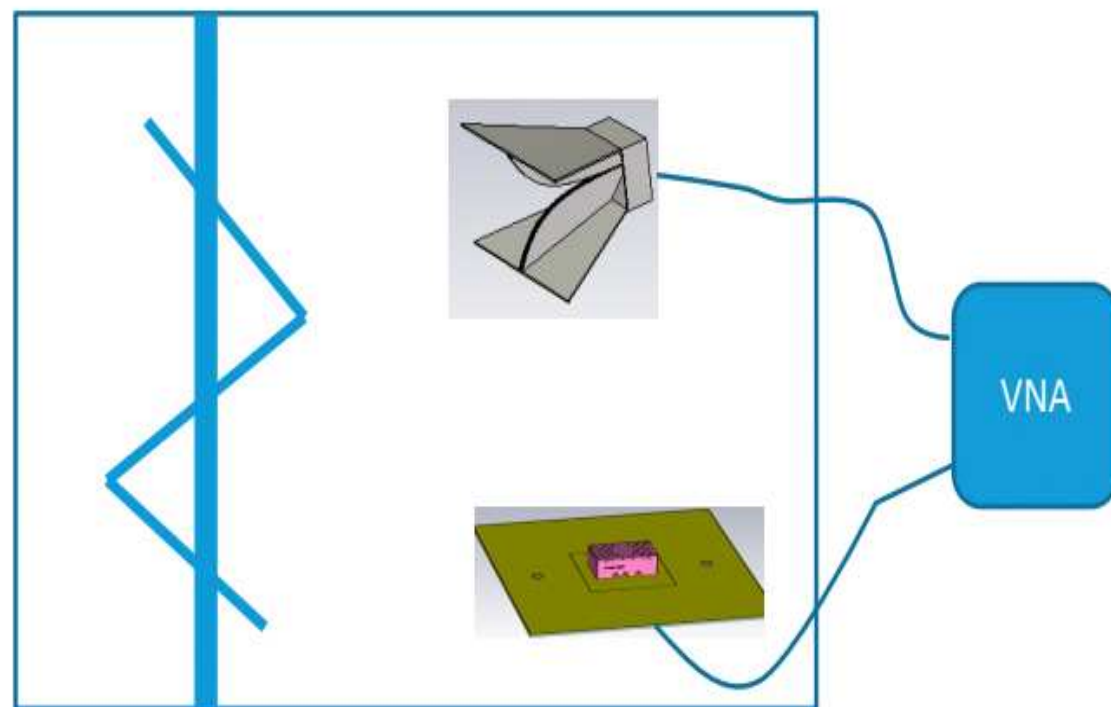



Sample test jig

Laird SE test jig - open



Laird SE test jig – with shield

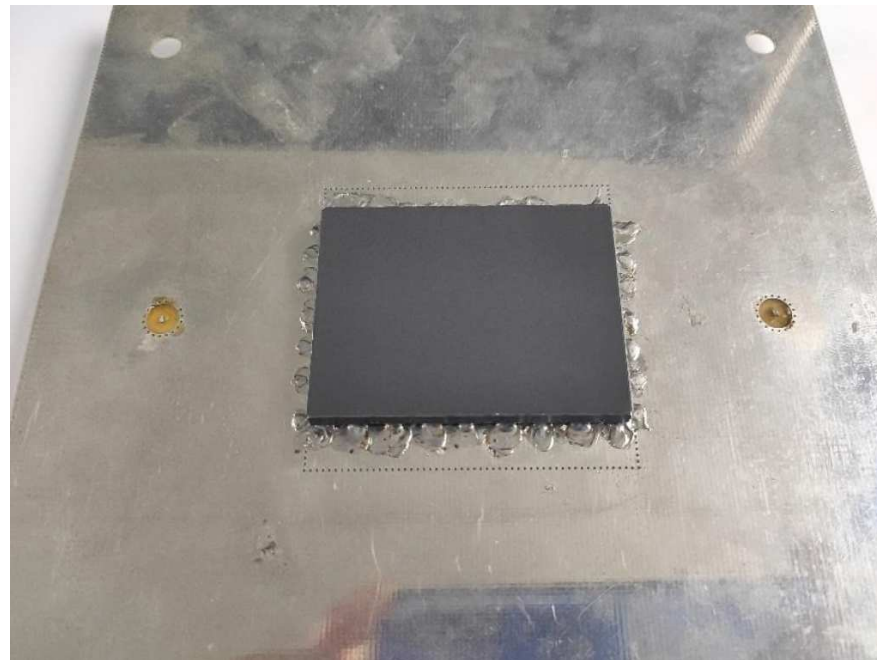



UoY Measurement setup

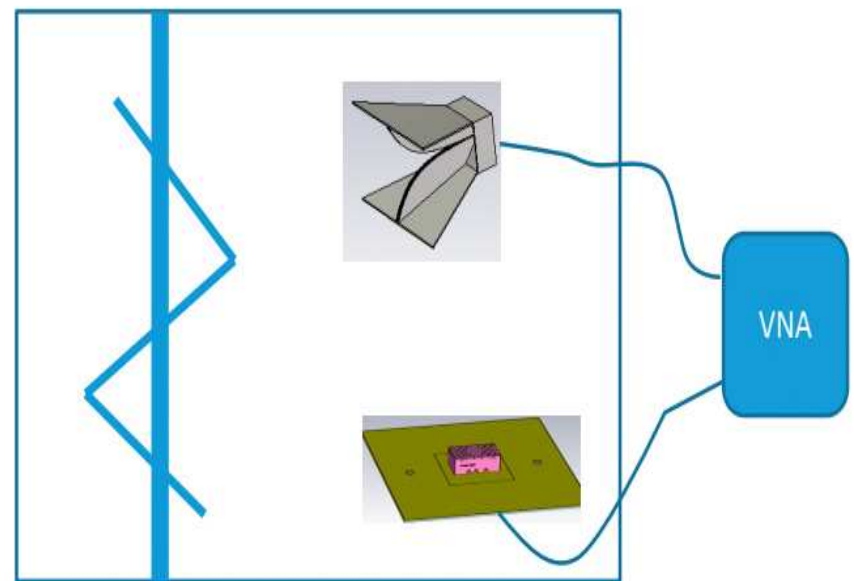
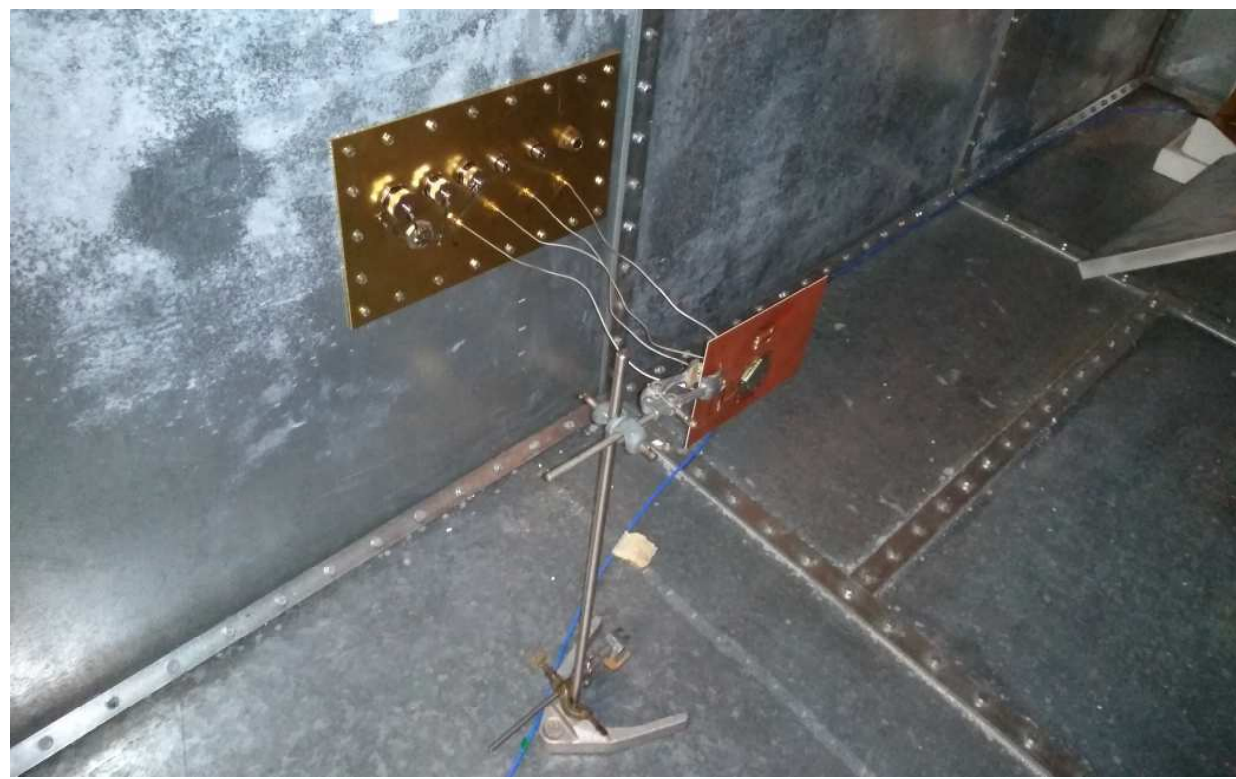



UoY Sample test jig 1

Top view - no shield

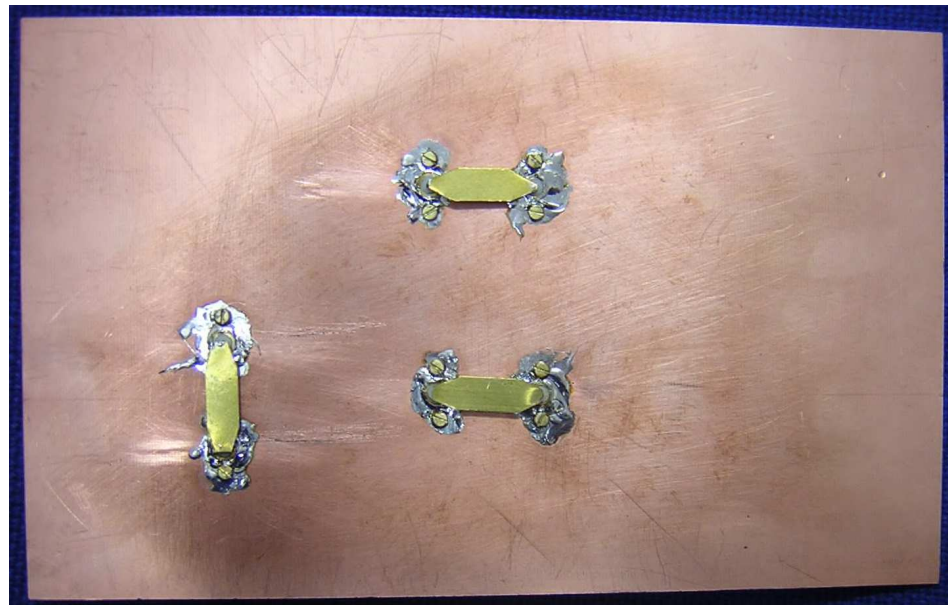

Side view- no shield



Sample test jig

UoY SE test jig 1 – with shield

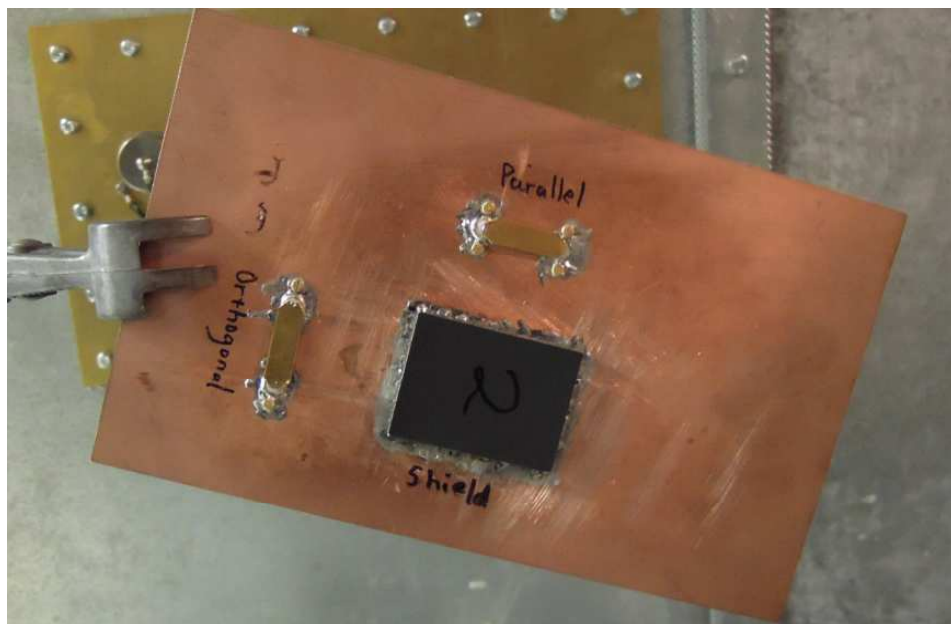

UoY SE test jig 2 – with shield

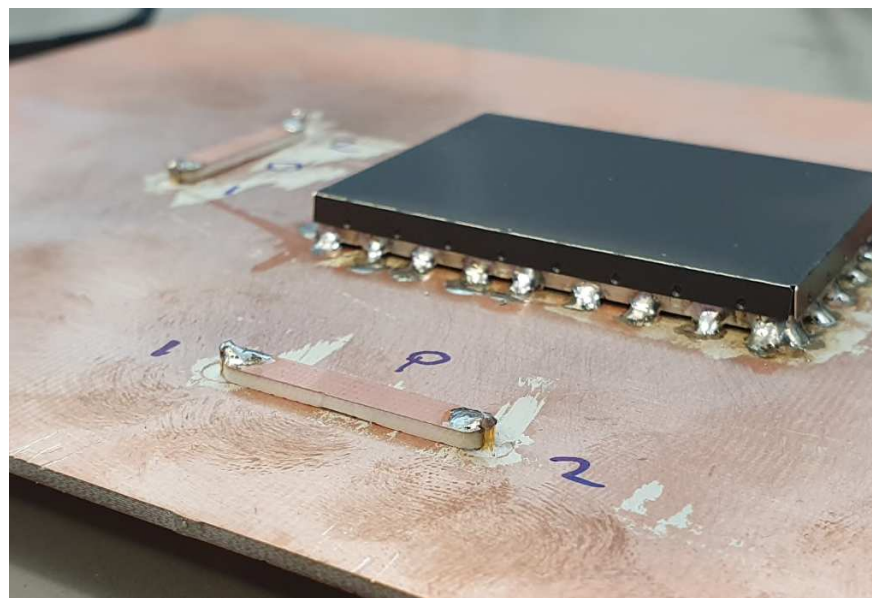



Definitions of SE

- IEEE 299
 - **shielding effectiveness (SE):** The ratio of the signal received (from a transmitter) without the shield, to the signal received inside the shield; the insertion loss when the shield is placed between the transmitting antenna and the receiving antenna.
- IEC 6100-4-21 standard gives a definition:
 - $SE = \frac{\langle P_u \rangle}{\langle P_s \rangle}$ or in decibels $SE = 10 \log_{10} \left(\frac{\langle P_u \rangle}{\langle P_s \rangle} \right)$ dB
 - Where P_u is the power coupled to a measurement antenna in the absence of a shield (unshielded) and P_s is the power coupled to a measurement antenna inside a shield (shielded) and $\langle x \rangle$ indicates that x is averaged over a number of measurements with different boundary conditions (stirrer positions, antenna positions, frequencies etc.).



Dynamic range

Laird Dynamic range test

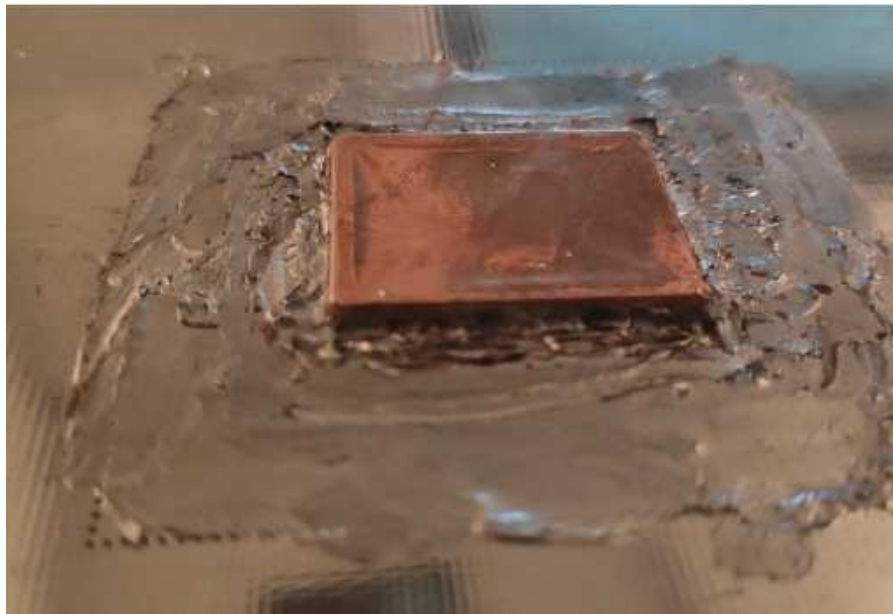

Dynamic range – Measure SE with:

- Laird
 - Solid copper shield over track
- UoY
 - Disconnect jig and terminate cable with matched load
 - Antenna remains connected



Dynamic range for Reverb method

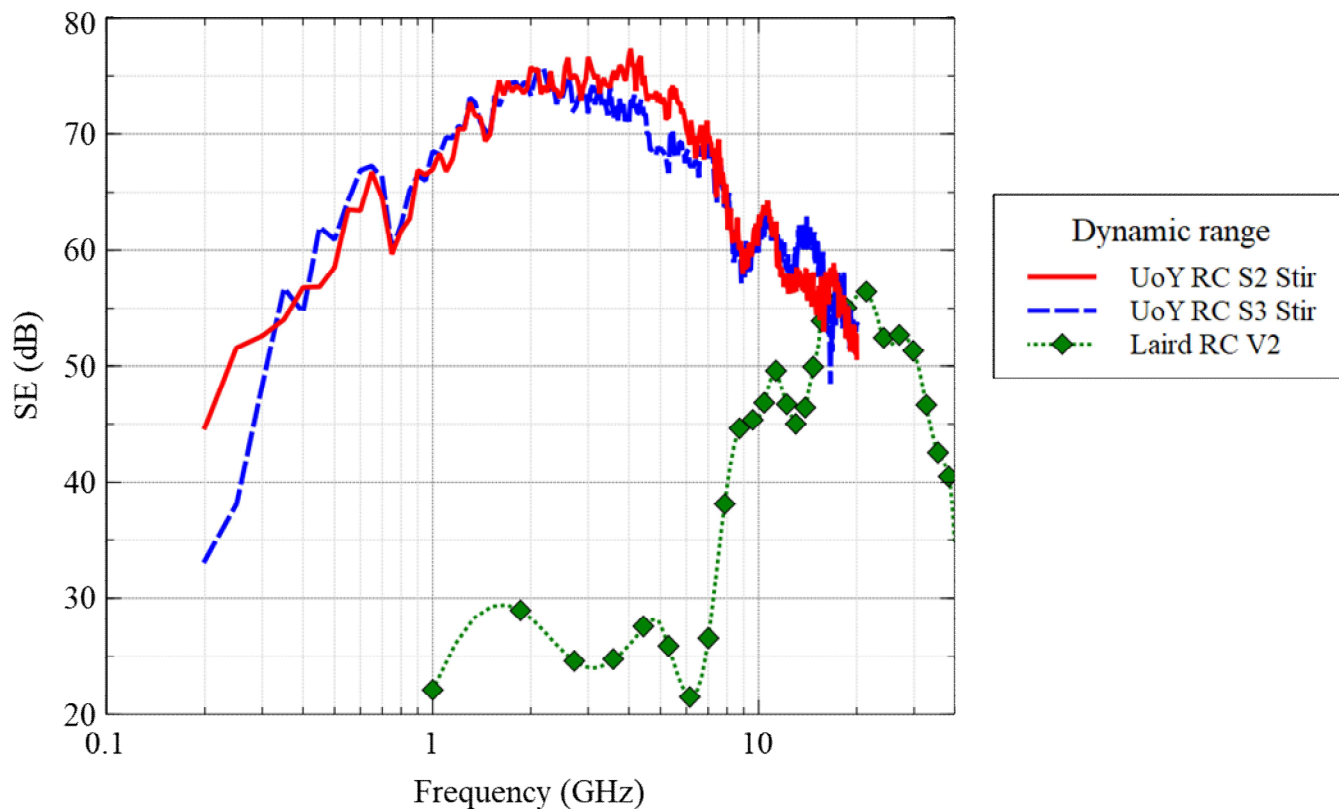

UoY :
 4.7m×3.0m×2.37m (*L × W × H*)
 100 Stirrer positions

Laird:
 2.5m×2.5m×2.5m

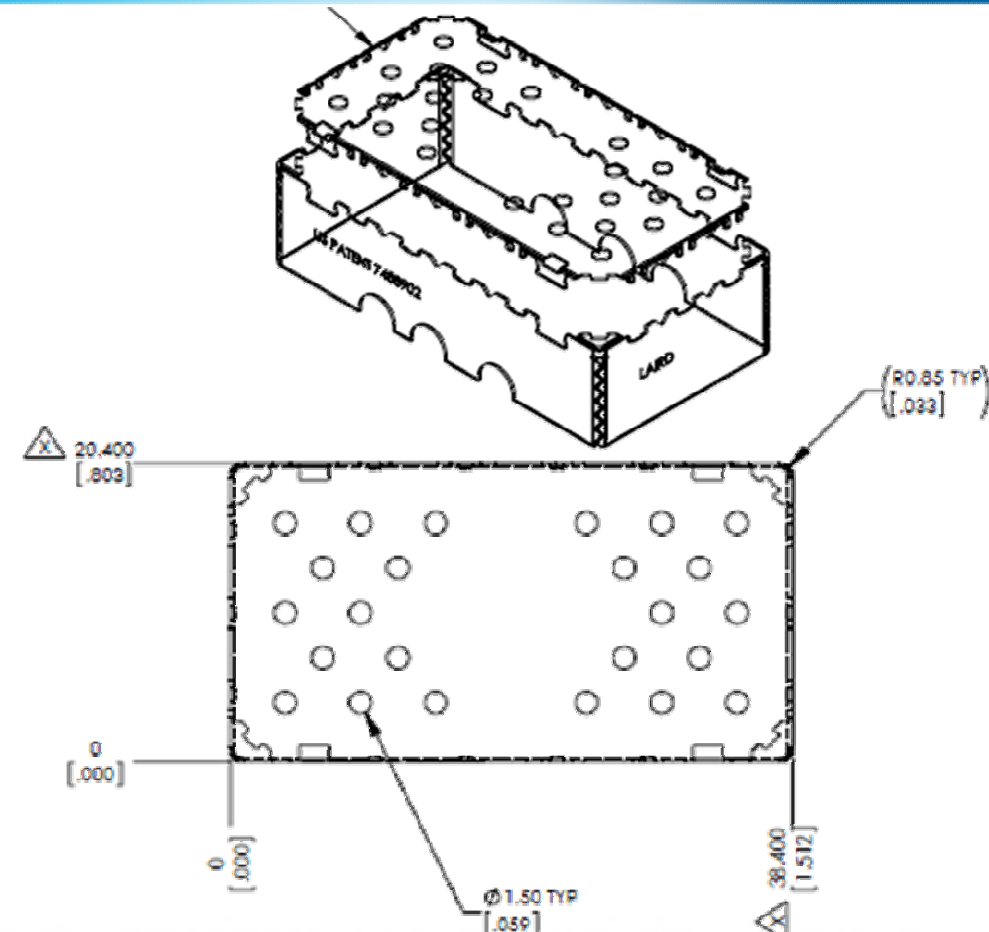
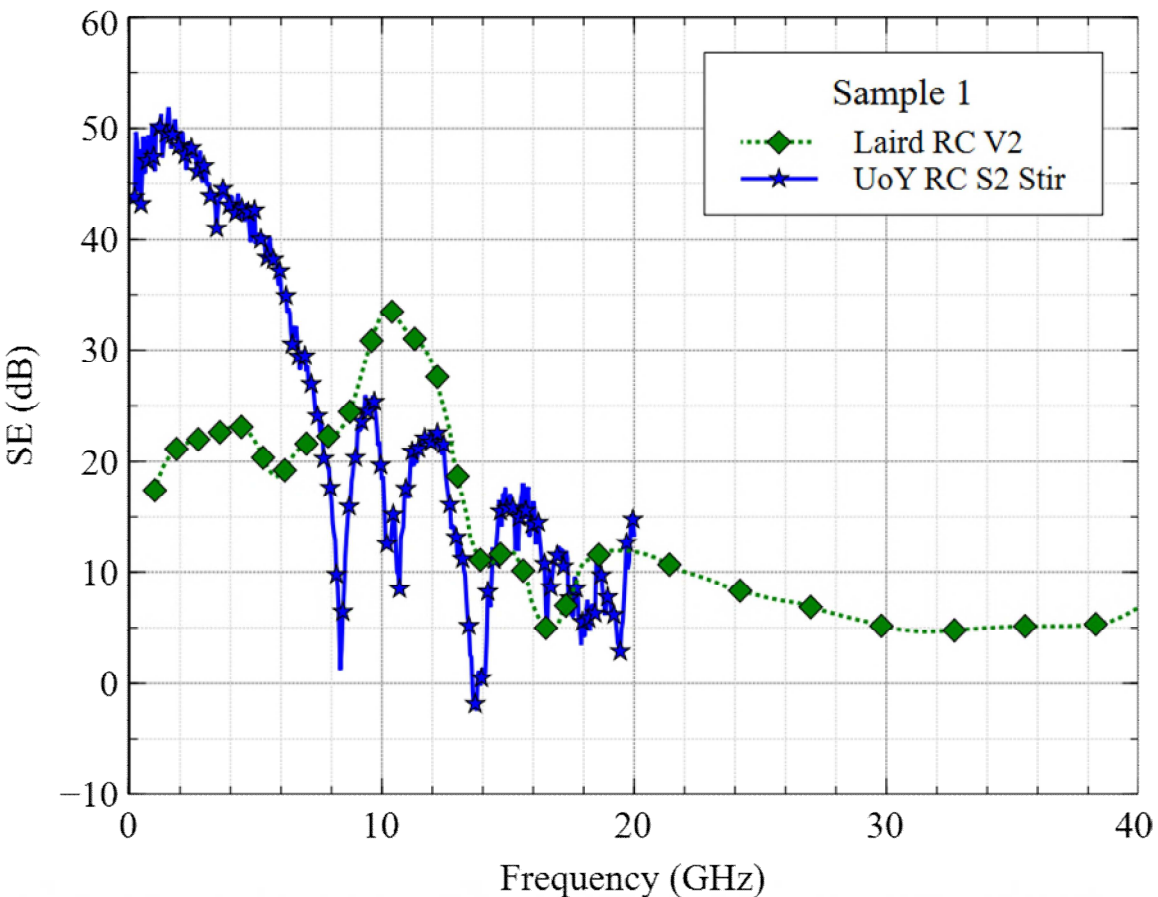



Initial measurements of Sample 2

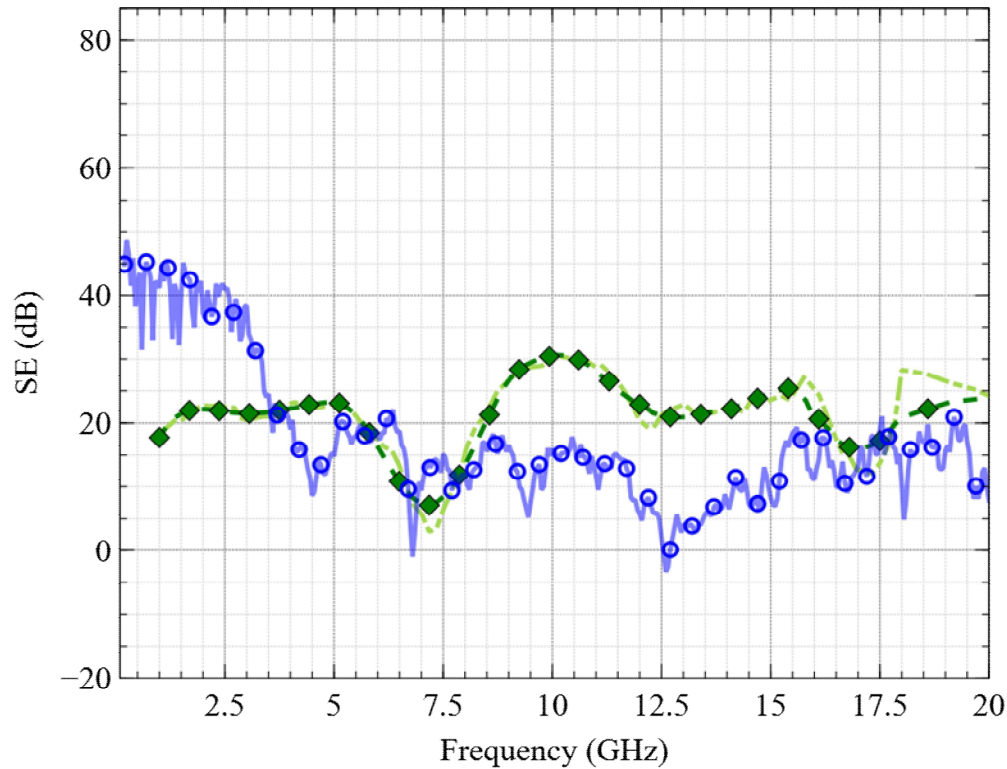

Sample 2

- UoY S2 RC Ant tot
- Laird V2 tot
- Laird V1 tot

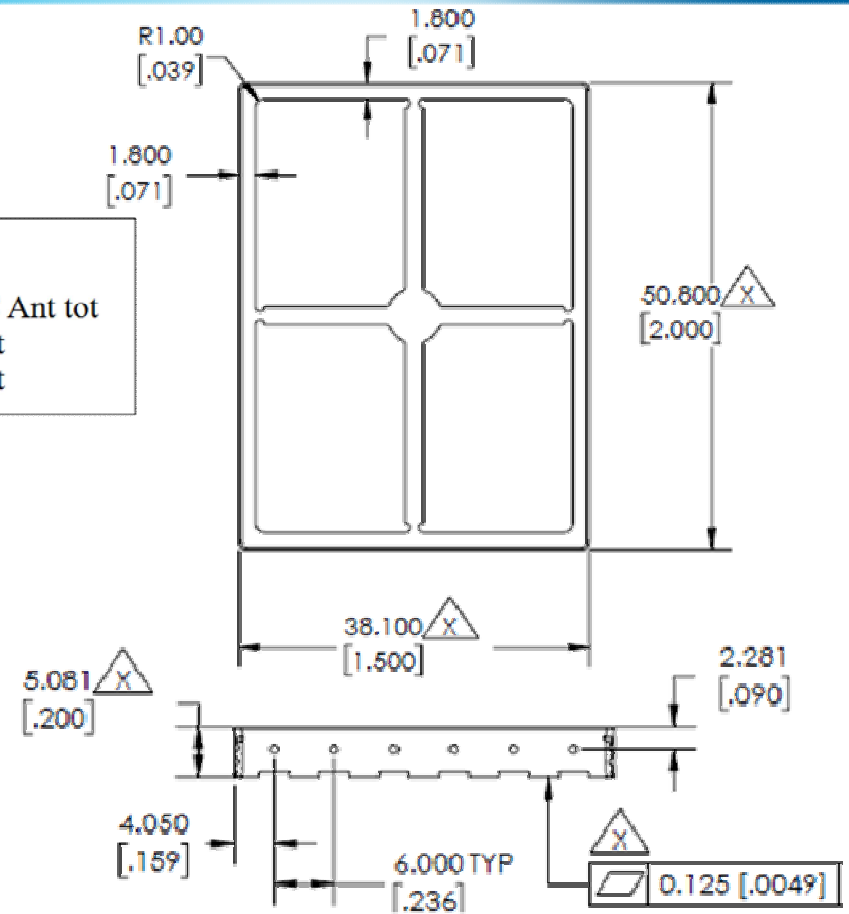



Adding UoY S3 measurement of Sample 2

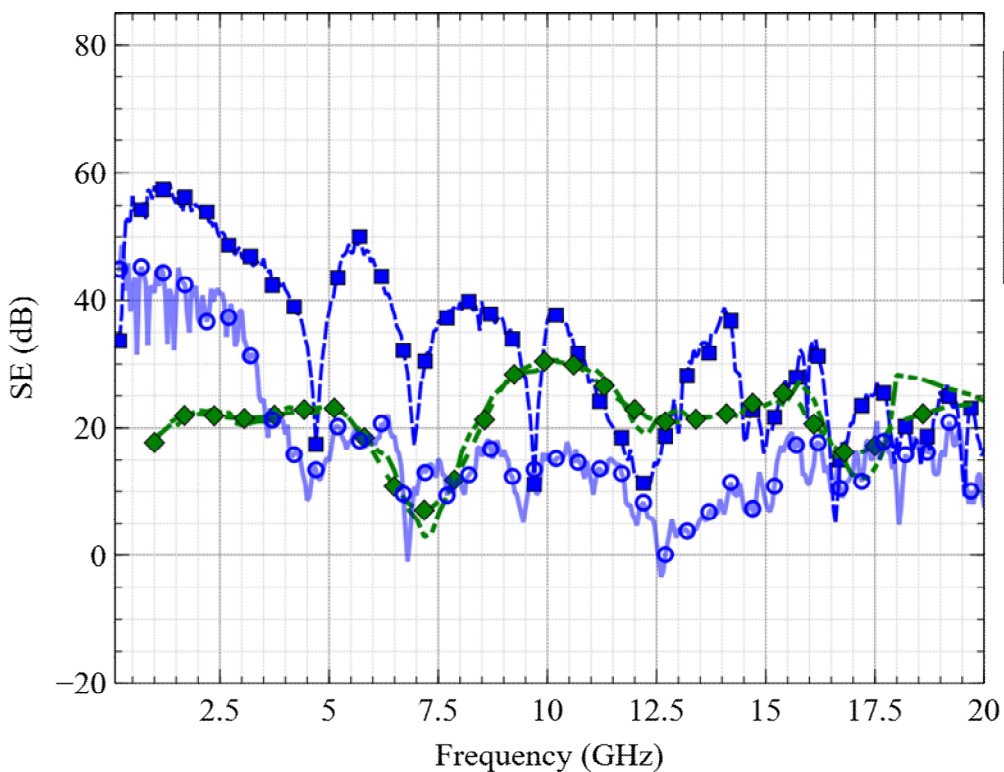

- Sample 2
- UoY S2 RC Ant tot
 - ◇— Laird V2 tot
 - — — Laird V1 tot
 - UoY S3 RC Ant2 tot

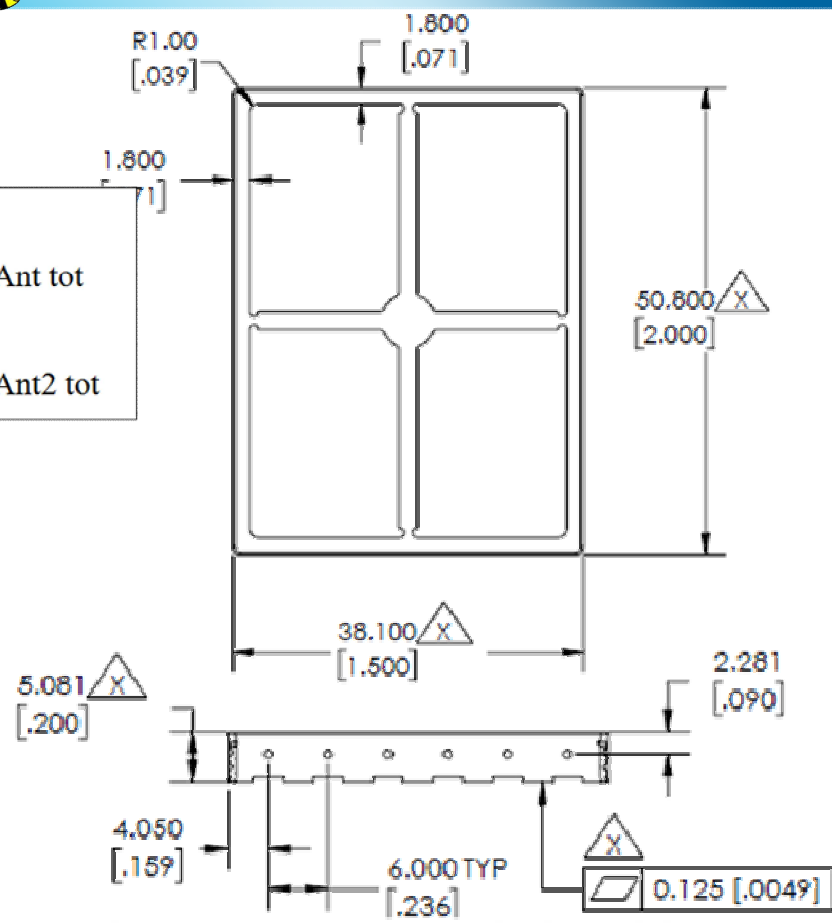



Now add UoY and Laird CST Models of Sample 2

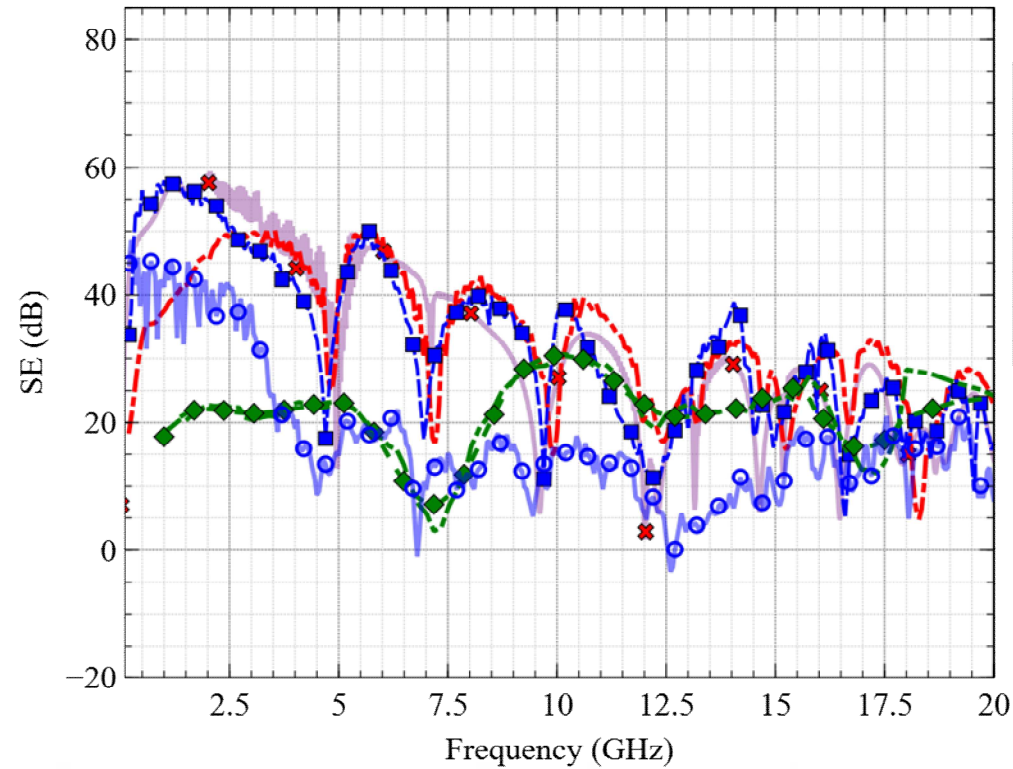

- Sample 2
- UoY S2 RC Ant tot
 - Laird V2 tot
 - Laird V1 tot
 - UoY S3 RC Ant2 tot
 - UoY S3 CST tot
 - Laird V3 CST Laird

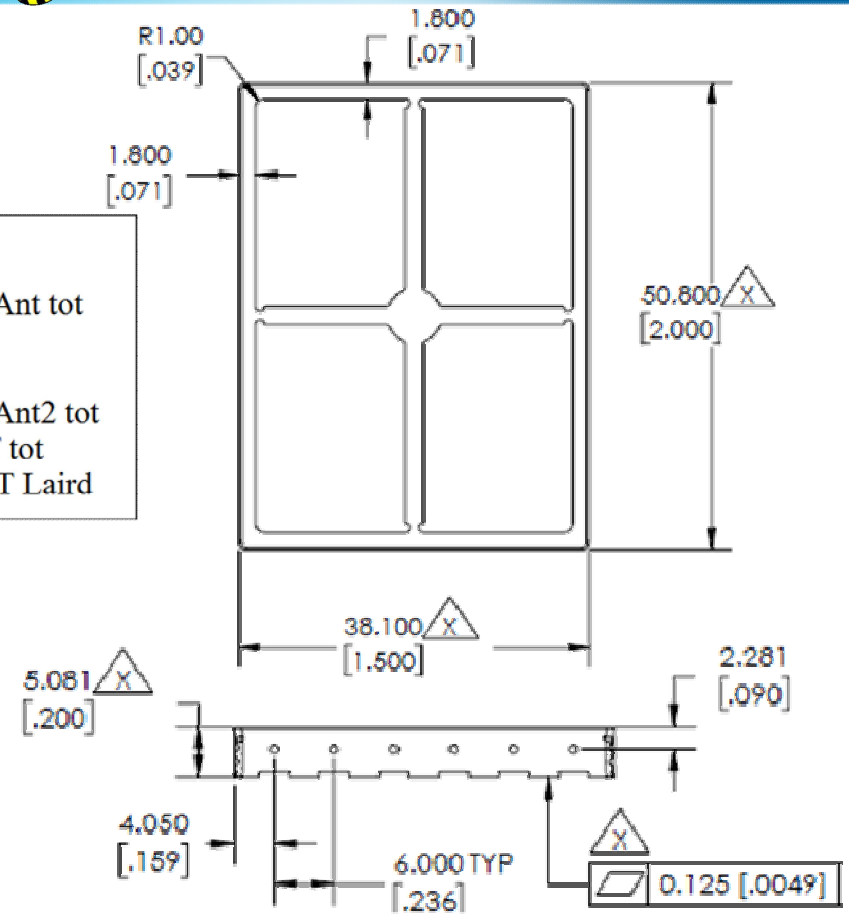



And finally Laird's V3 measurement of Sample 2

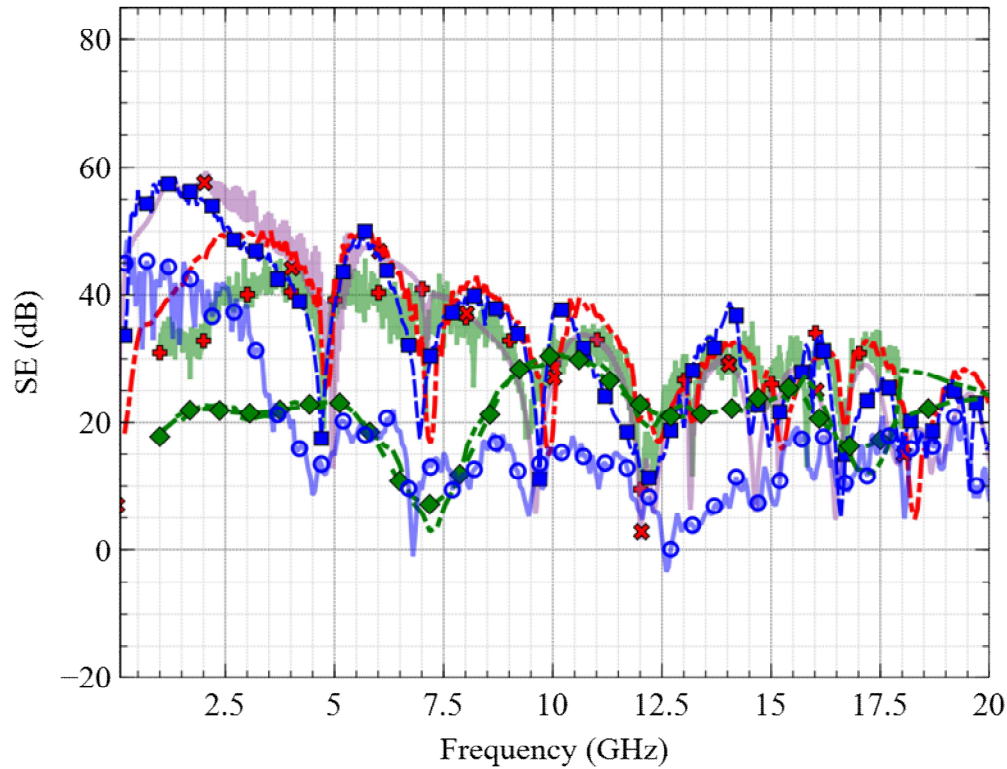

- Sample 2
- UoY S2 RC Ant tot
 - Laird V2 tot
 - Laird V1 tot
 - UoY S3 RC Ant2 tot
 - UoY S3 CST tot
 - Laird V3 CST Laird
 - Laird V3 RC Tot

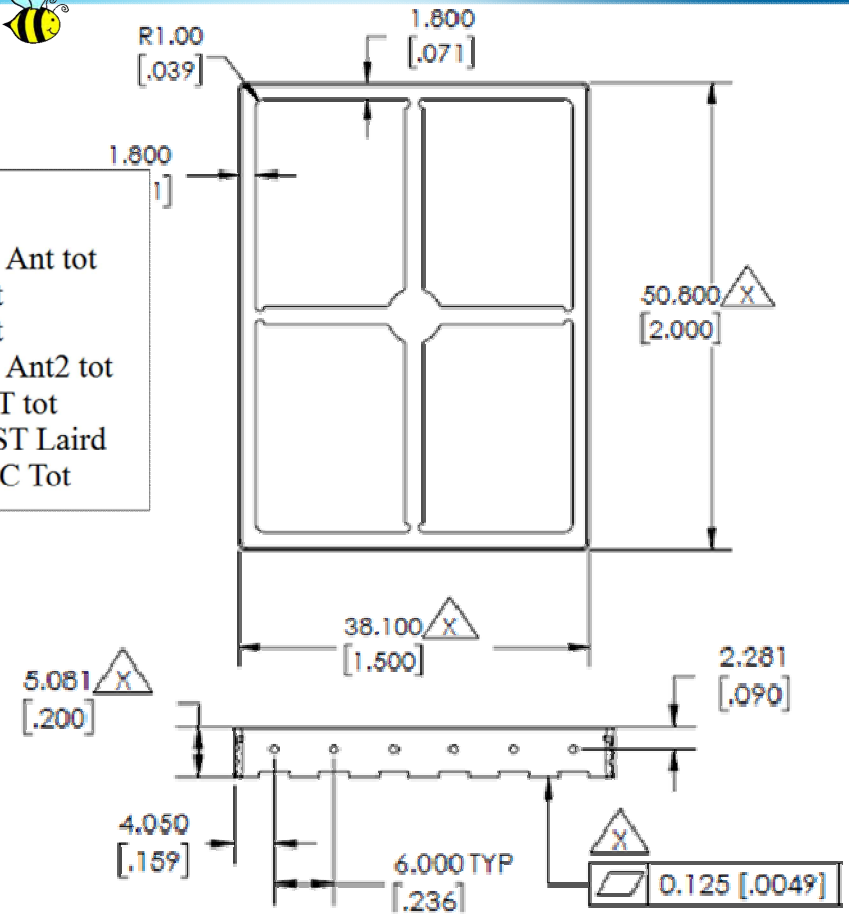

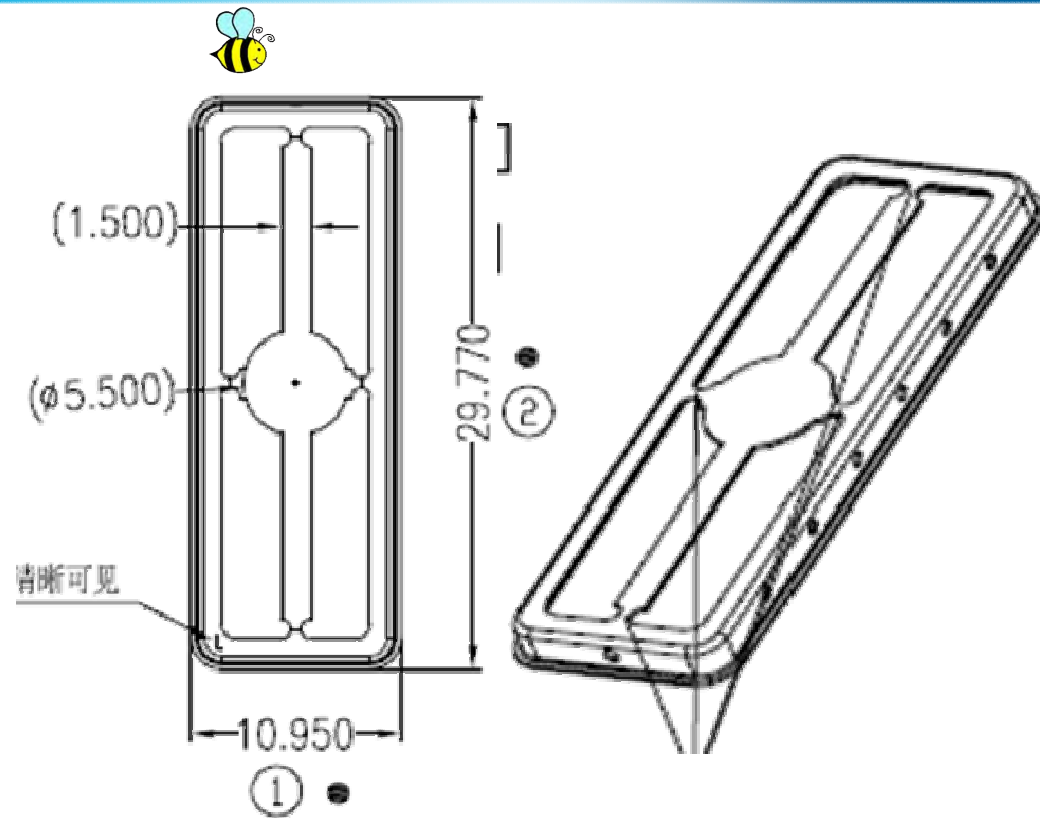
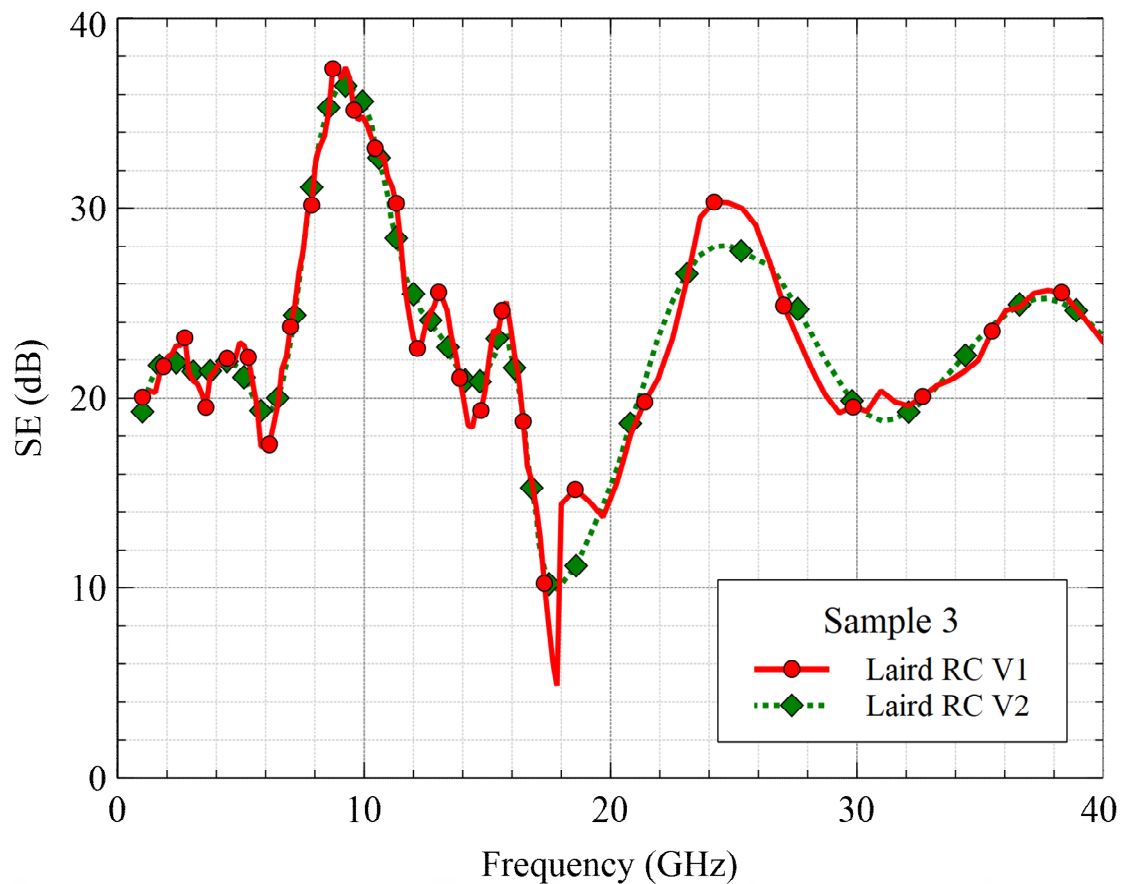

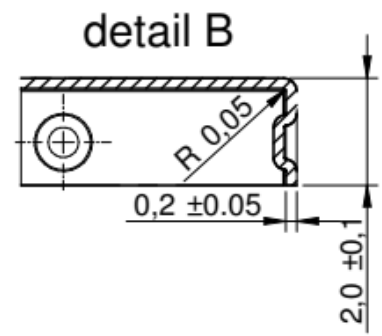
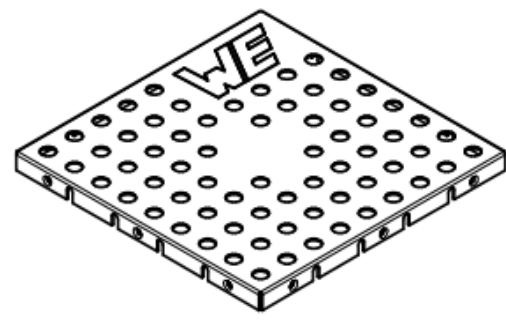
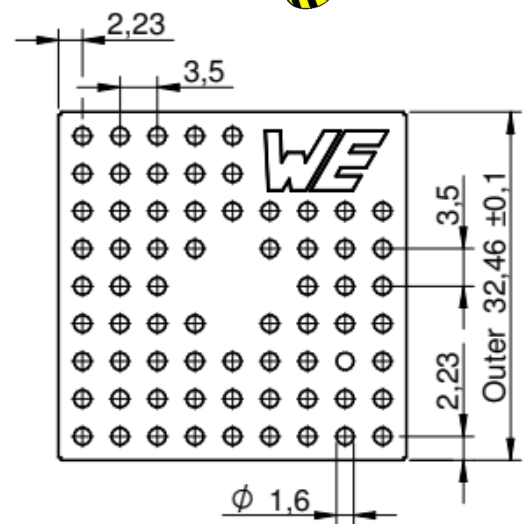
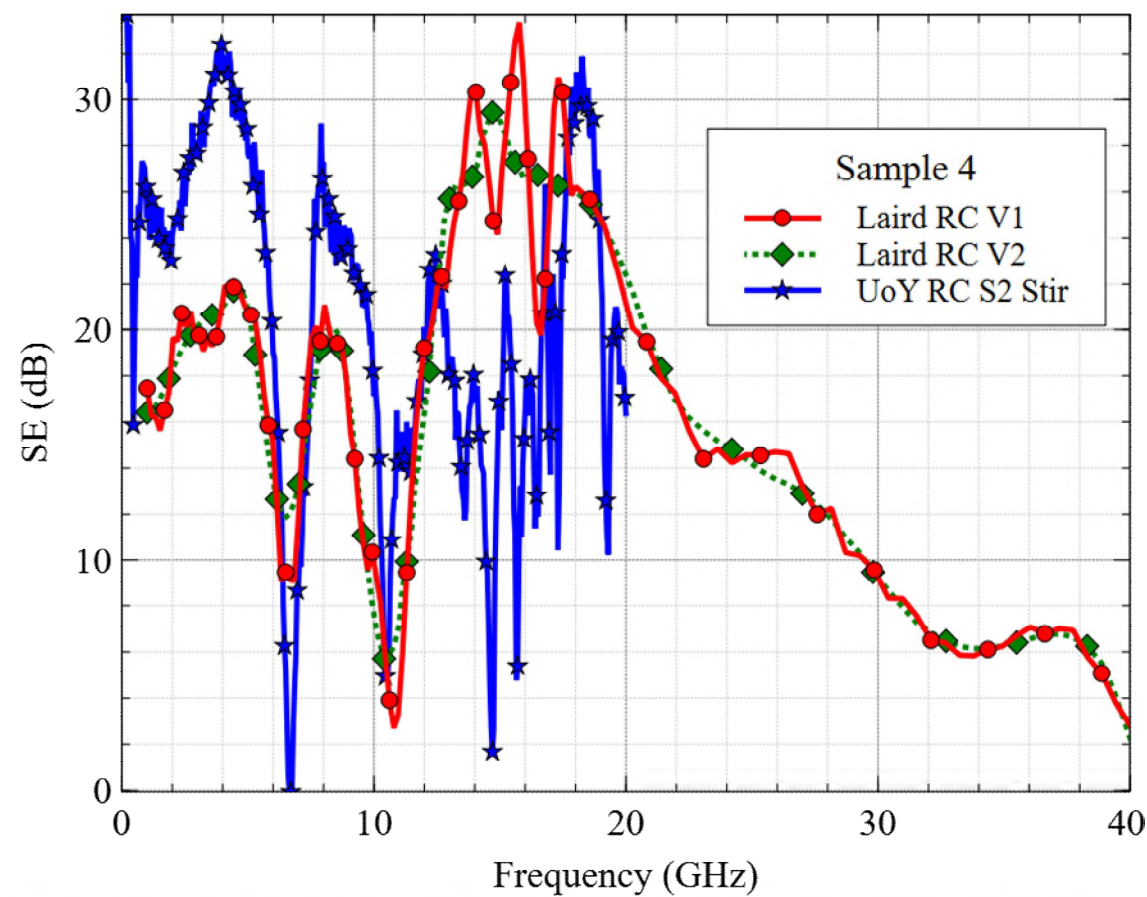

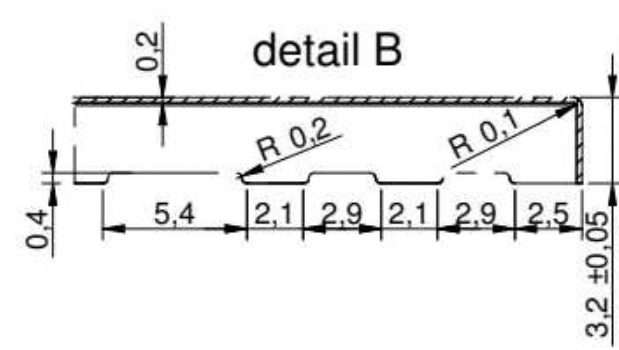
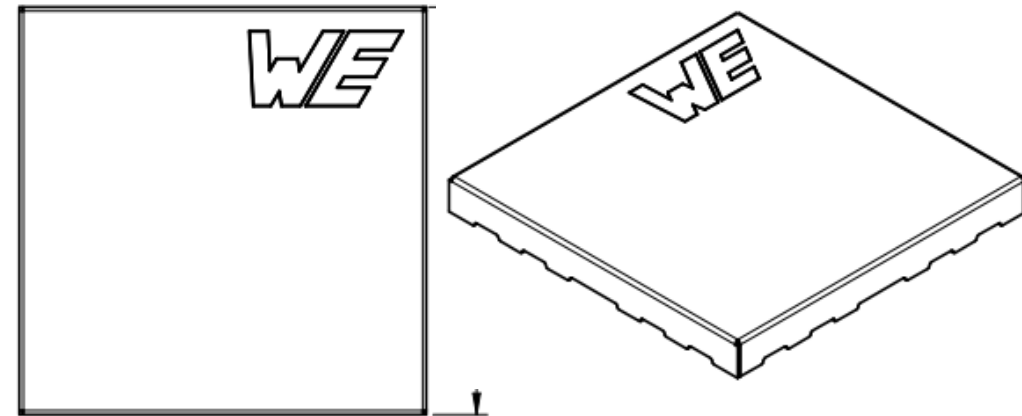
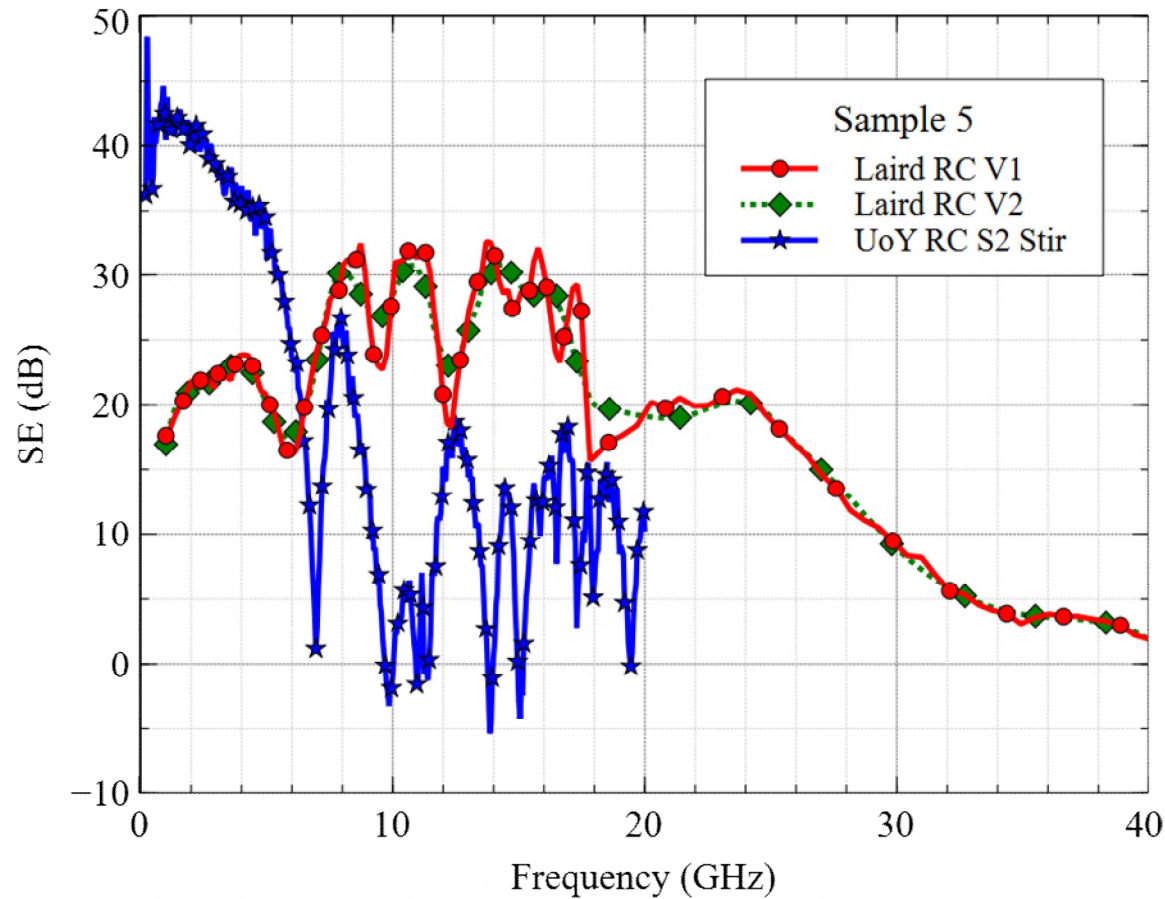

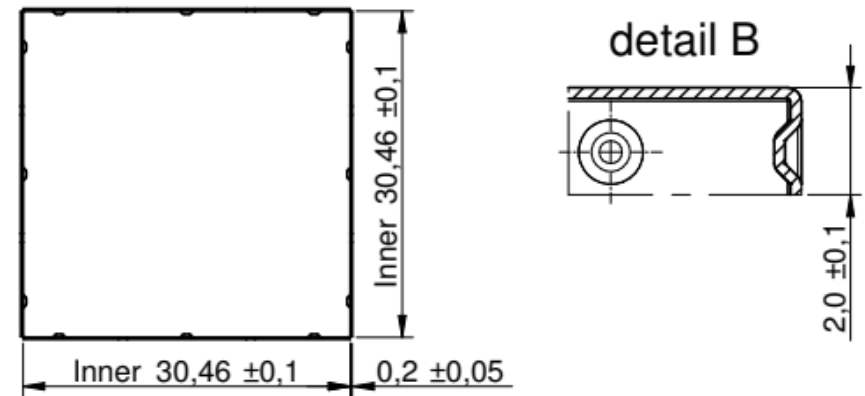
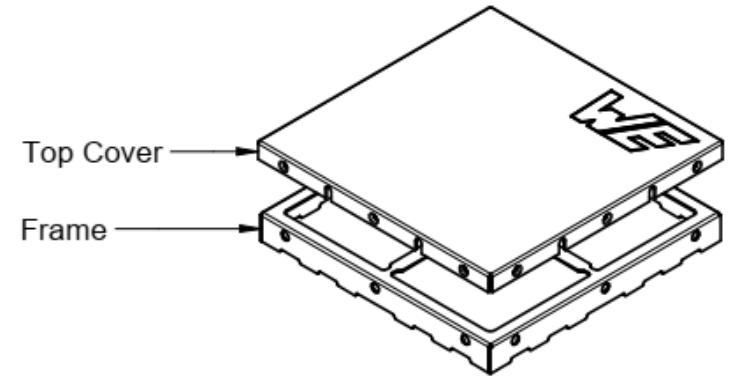
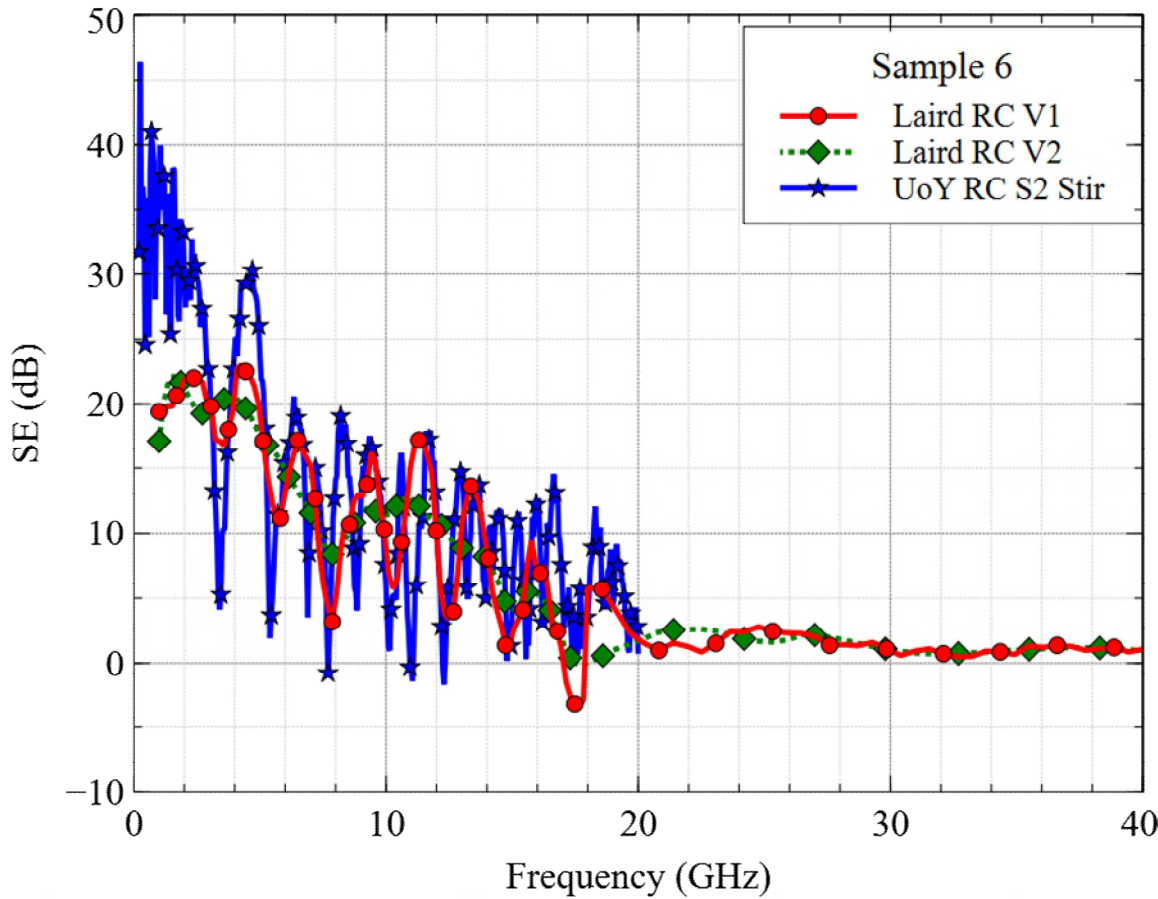

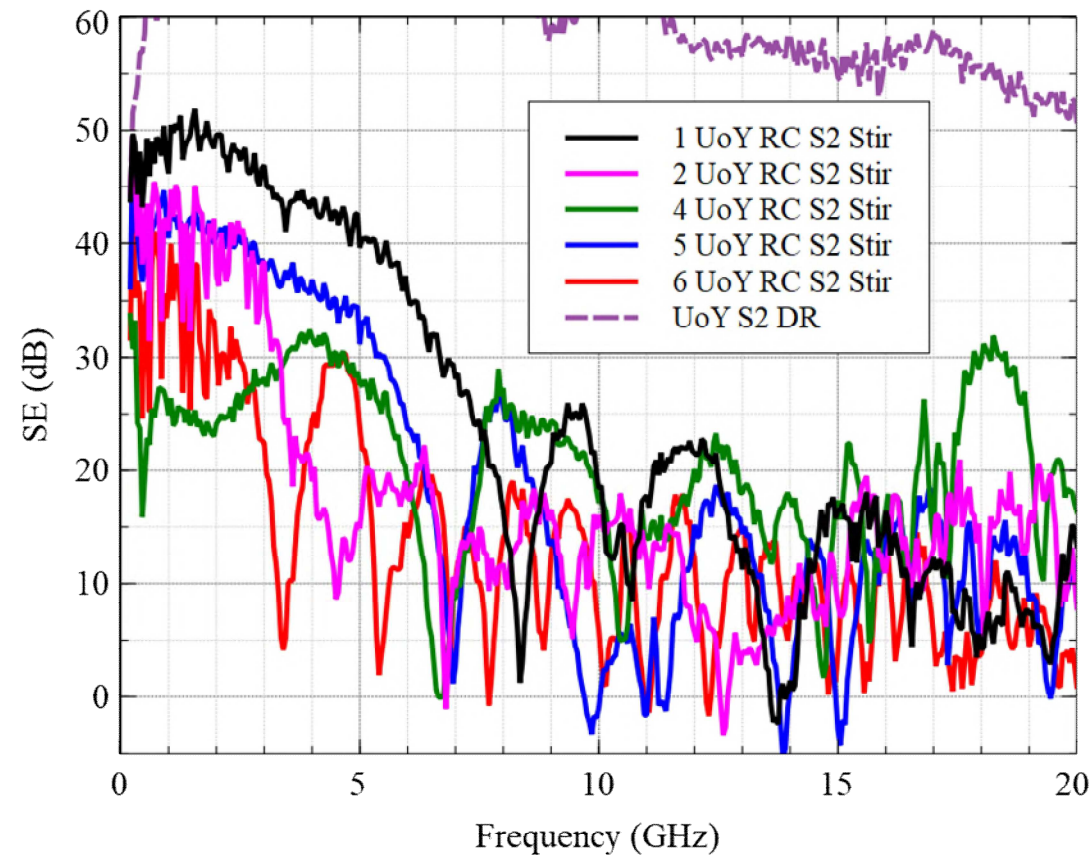
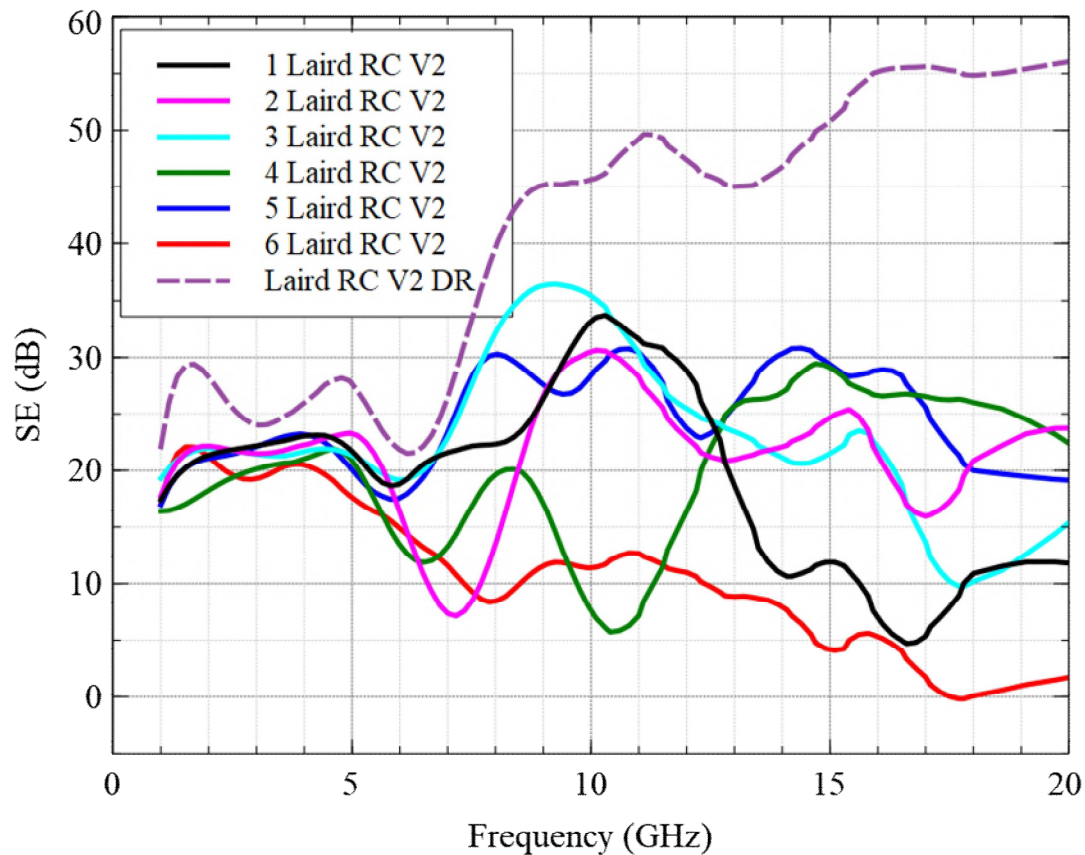



Statistics of SE

Usual definition of SE taking average of received power.

$$SE_{tot} = 10 \log_{10} \left(\frac{\langle |S_{21u}|^2 \rangle}{\langle |S_{21s}|^2 \rangle} \right) \text{ dB}$$

The *Point SE* is the SE of the shield at each stirrer position with both direct and scattered energy included. This shows the range of variability of the SE that may be encountered in a range of external environments.

$$SE_{point(mean \text{ dB})} = \left\langle 10 \log_{10} \left| \frac{S_{21u}}{S_{21s}} \right|^2 \right\rangle \text{ dB}$$



Shielding at 500 MHz, mean: 54.1 dB, std: 8.2 dB

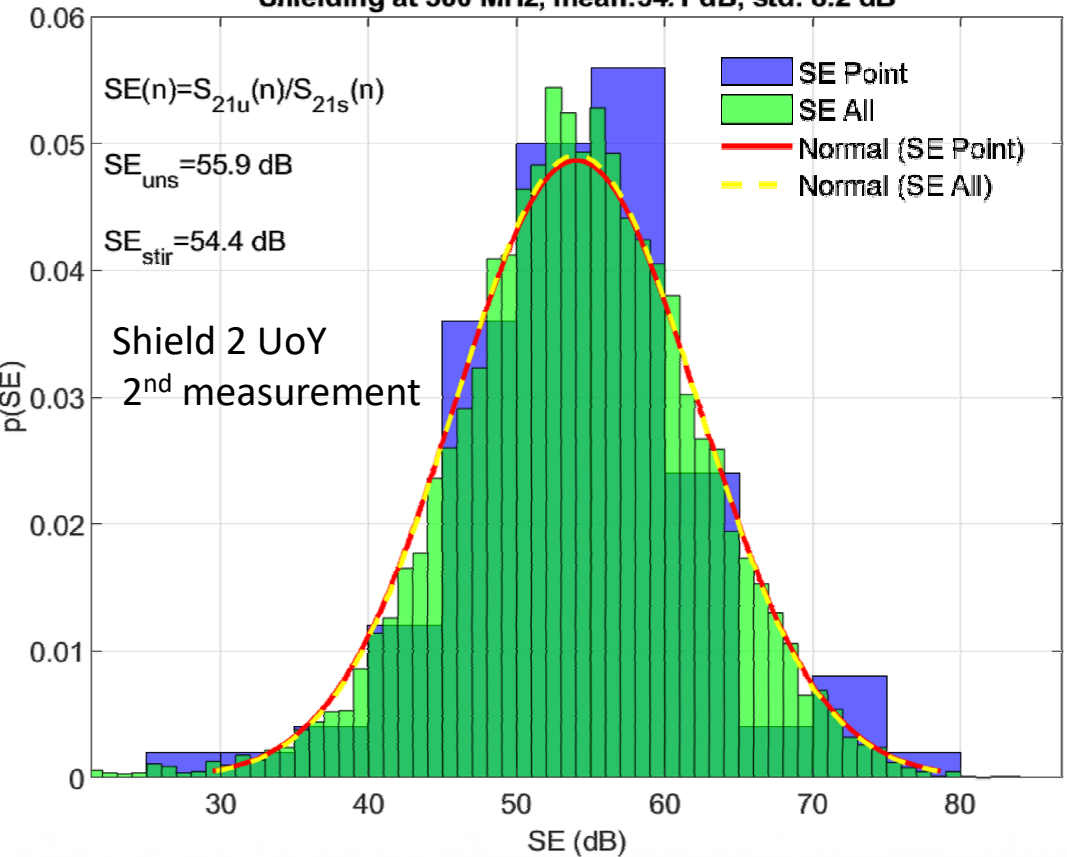

Shielding at 2000 MHz, mean: 56.0 dB, std: 7.4 dB

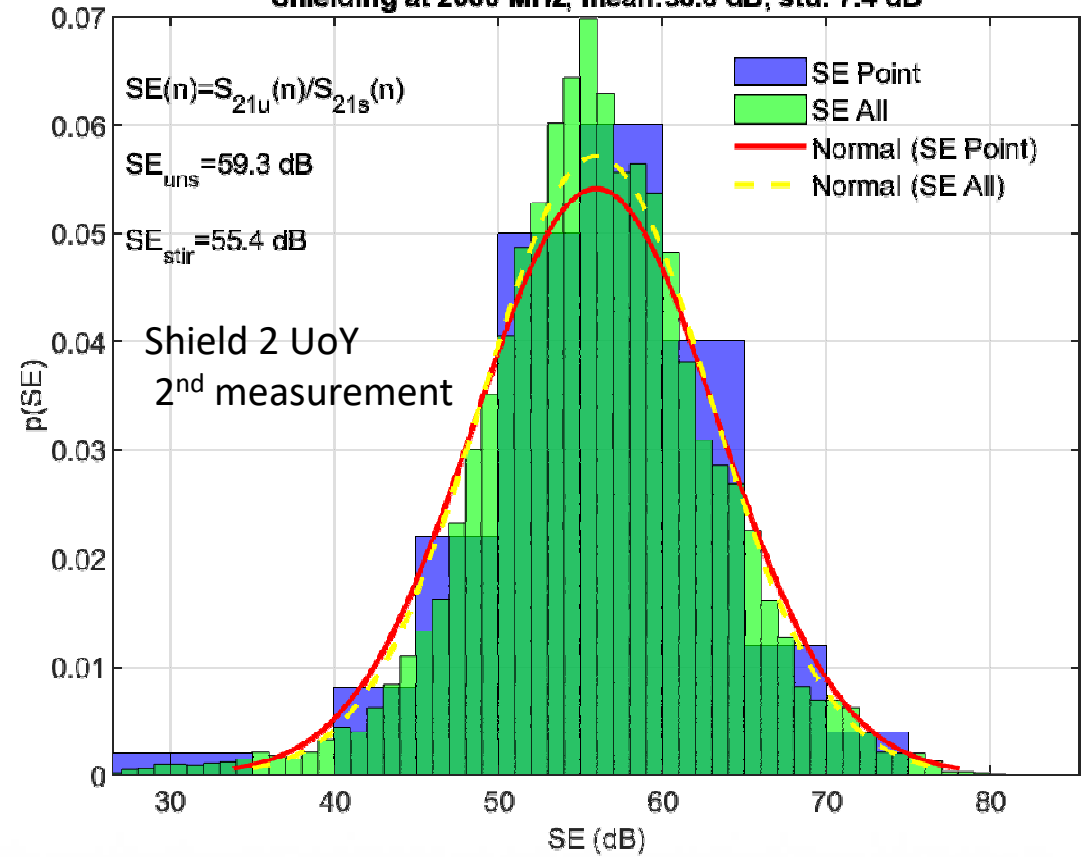

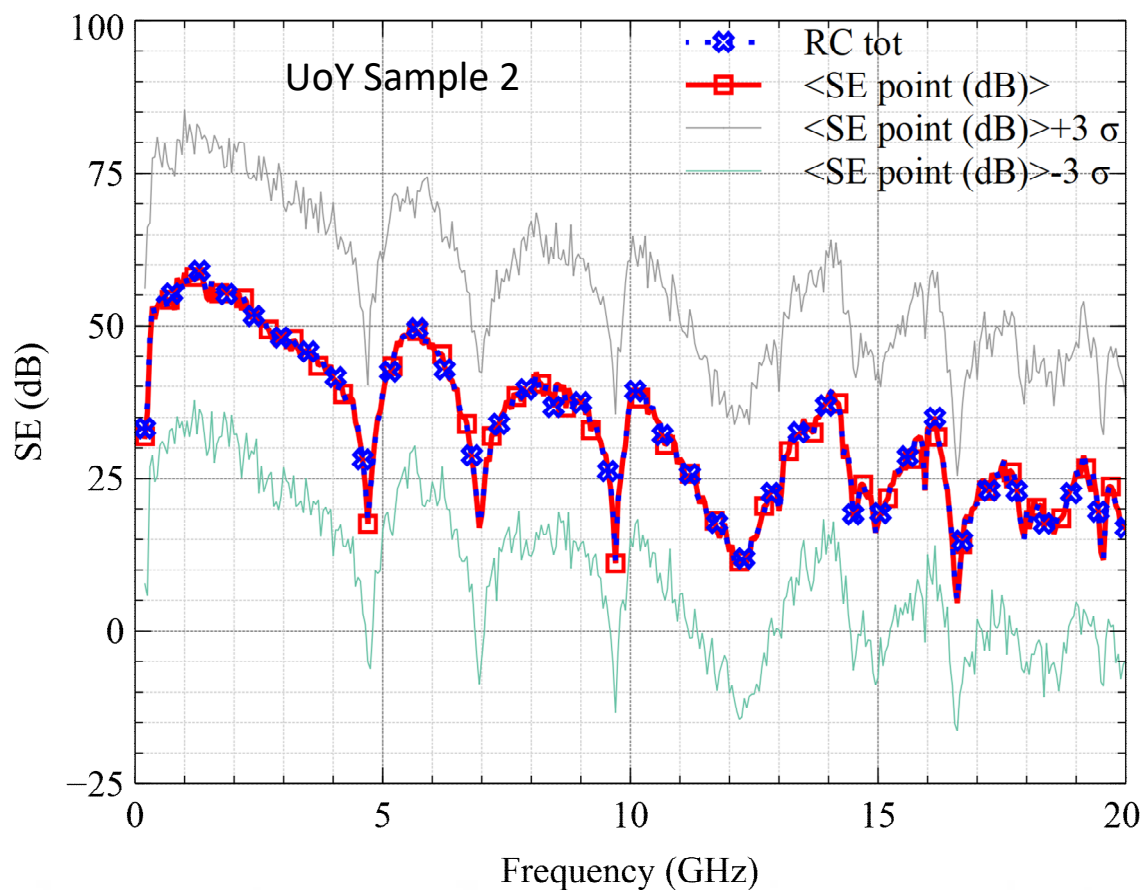

- $SE_{point}(\text{mean dB})$ close to Std SE
- Standard deviation $\sigma \approx 8dB$
- So limits of SE variation
 - $\pm 3\sigma \approx \pm 24dB$
- In taking a mean we sometimes lose sight of reality....
- See also
 - 10.1109/EMCEUROPE48519.2020.9245741
 - and
 - "Experimental Verification of Board Level Shielding Variability at Microwave Frequencies"

Final Remarks

- Single reverb method is closest to real use
 - BUT contents still not the same as in real use which may affect result
- Measurements to date show significant difference between slightly different jigs
- Is this jig geometry or measurement/jig fault ?
 - Re-test and modelling of shield 2
 - Modelling suggests jig/measurement problem with initial measurements
 - Repeat measurements and modelling correspond more closely
- Further investigation ongoing