

A 1.3 GHz, High Voltage Mesoband Dipole Antenna for IEMI Testing

John F. Dawson¹, Tim Rees², Barney Petit², Richard Hoad², Simon Bale¹, Mark Hough¹, Linda Dawson¹, Martin Robinson¹, Andy Marvin¹, Iain Will¹, and S J Porter¹

¹Department of Electronic Engineering, University of York, York, UK, email: john.dawson@york.ac.uk

²QinetiQ, Farnborough, UK, email: BJPETIT@qinetiq.com

Abstract— A resonant dipole antenna for testing immunity of equipment to intentional electromagnetic interference (IEMI) is described, along with simulated and measured test results which are in good agreement and demonstrate the high voltage operation.

I. INTRODUCTION

In this paper we present the design simulation and measurement of a high voltage dipole antenna which provides a damped sinusoidal pulsed fields working with a pulsed source. The antenna is intended to work with a single pulse generator [1] having a double exponential waveform with a rise-time of 90 ps a FWHH of 2.5 ns and an output amplitude of up to 34 kV.

II. ANTENNA DESIGN

Optimisation of the antenna was carried out using the CST Microwave studio time domain solver.

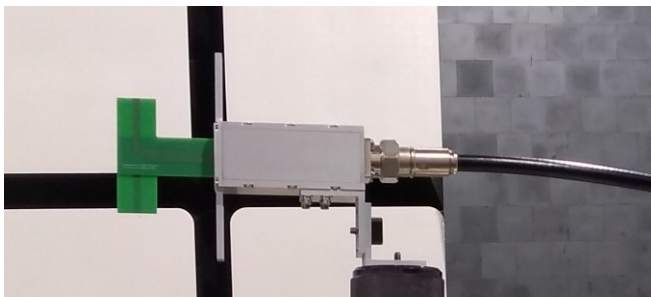

Fig. 1. 1.3 GHz dipole under test in QinetiQ's anechoic chamber

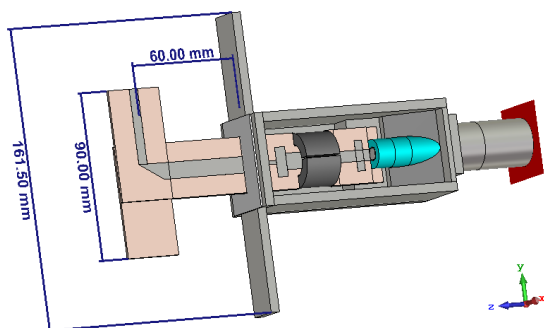

Fig. 2. View of simulation CAD model with enclosure lid removed

As the case size was comparable to the dipole it was decided to use a reflector to control the interaction of the case and antenna (Fig. 1). A compact transition from the modified high voltage 7-16 connector was manufactured using a polypropylene insulator and an aluminium taper to feed a FR4 circuit board based matching network, ferrite bead balun, low-pass filter, and antenna (Fig. 2).

III. RESULTS AND CONCLUSIONS

Measurements of the antenna performance were carried out in QinetiQ's Anechoic chamber using both a Vector network analyser (VNA) and a high voltage pulse source with D-dot sensor and 20 Gsample/s sampling oscilloscope.

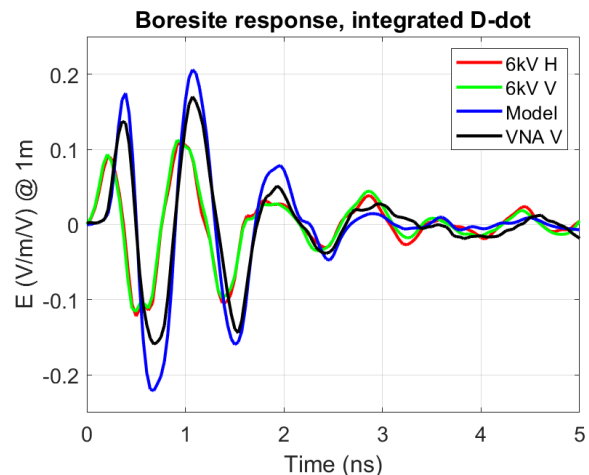

Fig. 3. Comparing Hyperband antenna numerical model results with VNA and pulse measurement

Fig. 3 shows the received pulse scaled to 1 V excitation and 1 m distance. For the frequency domain measurement (VNA V) with a VNA the pulse response is obtained from the inverse FFT of the transmission measurement convolved with the expected source pulse. Two measurements are shown with the pulse generator set to 6 kV with the antenna in vertical and horizontal polarisations. In all cases the measurements are adjusted for D-dot sensor cable and cable losses, the pulses are offset in time to allow the initial peak to be clearly seen. The lower amplitude of measured with the pulse generator may be due to the pulse shape and amplitude differing from the ideal assumed in the model and VNA results.

Overall the antenna performs as predicted during the design phase with slightly reduce field levels. The reflector provides increased field level compared with a simple dipole.

Take-Home Messages:

- A high voltage pulse driven 1.3G Hz Mesoband dipole
- Robust simple to build antenna for IEMI testing
- Operates from external Broadband pulse generator
- Simple high voltage balun and low pass filter
- Computational model matches measured results

REFERENCES

- [1] R. Hoad, L. Chatt, B. Petit, T. Rees, and G. Eastwood, "Mesoband and Hyperband Immunity Test Generator and Standards," in *AMEREM*, 2018.