



UNIVERSITY OF LEEDS

This is a repository copy of *A Novel Comprehensive SOC-Voltage Control Scheme for Lithium-ion Battery Equalization*.

White Rose Research Online URL for this paper:
<http://eprints.whiterose.ac.uk/172062/>

Version: Accepted Version

Proceedings Paper:

Lu, M, Fan, Y and Chong, B (2021) A Novel Comprehensive SOC-Voltage Control Scheme for Lithium-ion Battery Equalization. In: 2020 International Conference on Power, Instrumentation, Control and Computing (PICC). 2020 International Conference on Power, Instrumentation, Control and Computing (PICC), 17-19 Dec 2020, Thrissur, India. IEEE , pp. 1-6. ISBN 978-1-7281-7591-1

<https://doi.org/10.1109/PICC51425.2020.9362458>

© 2020 IEEE. Personal use of this material is permitted. Permission from IEEE must be obtained for all other uses, in any current or future media, including reprinting/republishing this material for advertising or promotional purposes, creating new collective works, for resale or redistribution to servers or lists, or reuse of any copyrighted component of this work in other works.

Reuse

Items deposited in White Rose Research Online are protected by copyright, with all rights reserved unless indicated otherwise. They may be downloaded and/or printed for private study, or other acts as permitted by national copyright laws. The publisher or other rights holders may allow further reproduction and re-use of the full text version. This is indicated by the licence information on the White Rose Research Online record for the item.

Takedown

If you consider content in White Rose Research Online to be in breach of UK law, please notify us by emailing eprints@whiterose.ac.uk including the URL of the record and the reason for the withdrawal request.



eprints@whiterose.ac.uk
<https://eprints.whiterose.ac.uk/>

A Novel Comprehensive SOC-Voltage Control Scheme for Lithium-ion Battery Equalization

Mowei Lu, Yejing Fan, Benjamin Chong
School of Electronic and Electrical Engineering
University of Leeds
Leeds, United Kingdom
el17ml@leeds.ac.uk, el17yf@leeds.ac.uk, B.Chong@leeds.ac.uk

Abstract—This paper proposes a novel comprehensive state of charge (SOC) and voltage control scheme for battery equalization. For the circuit topology, the equalizers contain balancing circuits based on buck-boost converter topology, which can guarantee bi-directional power flow between battery cells, and each cell is corresponding to one balancing circuit. For the control scheme, real time SOC of each cell is measured to determine the switching state of each balancing circuit so that equalization path can be changed accordingly. Real time voltage is also measured to minimize the load voltage ripple. PI controller is then applied to regulate both SOC and voltages across the battery cells through the adjustment of the switching duty ratios, thus making a trade-off between equalization speed and battery voltage fluctuations. The circuit topology is constructed in SIMULINK while the control algorithm is implemented in MATLAB. Simulation results of SOC, voltage and current are obtained to validate the control design.

Keywords— *buck-boost converter, PI controller, equalizing speed, voltage fluctuation, lithium-ion battery*

I. INTRODUCTION

Lithium-ion battery is the fastest growing and most promising battery chemistry for its long life cycle and little pollution [1]. It can be applied in many areas ranging from portable electronic devices such as mobiles and laptops to larger energy storage fields such as uninterruptible power supply and electric vehicle. Battery string needs to be formed by several battery cells to meet the requirement of applications since single cell can only provide limited energy [2][3]. However, due to the inconsistencies of battery internal resistance, battery capacity and operating temperature, the imbalance of state of charge and voltage in battery cell becomes a common problem. This problem may accelerate the degradation, thus reducing the efficiency and lifetime of battery pack. And it may even cause some severe safety problems such as fire and explosion. Therefore, it is necessary to develop battery equalization technique.

The balancing topologies can be divided into passive and active balancing [4]. The passive balancing circuits apply fixed or switched shunting resistor to consume the excess charge of overcharged battery, thus reaching equalization after a period of time. This method is simple and easy to control. However, it has low efficiency as it wastes some useful energy, which transfers as heat dissipation [5]. The active balancing circuits are based on the principle that excess charge can be shuffled from one cell to another through energy storage elements such as inductors and capacitors. In this way, energy is not wasted but used to re-charge other cells. Converter-based topology is a promising choice of active balancing circuits because converters can be controlled to be bidirectional for both charging and discharging through the whole balancing process [6].

Apart from the balancing topologies, appropriate control algorithm is also important, which are mainly divided into two types: voltage-based and state of charge (SOC)-based control scheme [7]. Voltage-based control is widely used in industry for its simplicity. Cells charge and discharge according to the direct voltage measurement. However, sometimes cell imbalance comes from the internal chemistry kinetics difference. In this case, voltage difference is just an indicator but not the underlying cause [8]. The voltage cannot reflect the real characteristics of batteries. Managing to balance the voltage directly may bring about other problems. Research [9] has shown that the voltage-based balancing control might lead a battery string to be even more unbalanced than without it. SOC-based control is more reasonable because SOC is the root cause of the voltage difference. When cells are balanced to the same SOC, their voltage will be balanced at the end.

Research [10] provides a balancing strategy of lithium-ion batteries based on change rate of SOC. In order to minimize power loss, this method limits the current flowing in and out of the batteries during the balancing process. However, it focuses on ideal unloaded situation without considering load current as well as load ripple. In [11], the authors propose a duty cycle adjusting method to cope with decreasing balancing speed. However, this algorithm is highly sensitive to voltage value. A little voltage ripple will lead to unstable response in duty ratio. In [12], the authors suggest a layered buck-boost converter balancing topology, which is modular and easy to control. However, that method is voltage-based and applies fixed duty ratio. It may not achieve real balance in SOC or take a long time to achieve it.

This paper proposes a novel PI control scheme, which takes SOC as the dominant factor while voltage as a detuning parameter. It achieves both fast balancing speed and small voltage fluctuation. Based on the battery cells' SOC, the operation mode can change whereby certain converters are activated automatically and transfer charge at an adaptive rate. The buck-boost converter operation principles are discussed in section II. Several sub control algorithms are explained in section III and the whole system design is presented in section IV. Simulation and results are given in section V. The section VI gives the conclusion of all work.

II. CIRCUIT TOPOLOGY & OPERATION

A. Single balancing circuit

Fig. 1 shows a single balancing circuit for two batteries system. This balancing circuit is derived from traditional buck-boost converter. The inductor is used to transfer energy between batteries. One diode and one controllable transistor-based switch (i.e. D_2 and S_1) form a balancing path. Two sets of them provide two balancing paths ensuring the bidirectional energy flow for both charging and discharging.

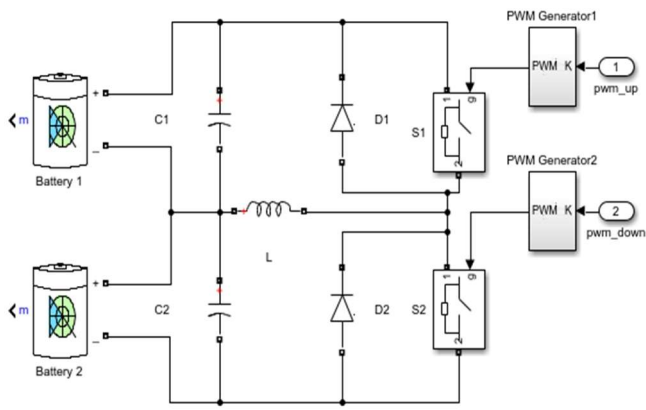

Fig. 1. Single bidirectional buck-boost converter

One case study where battery 1 is overcharged and battery 2 is undercharged is presented in Fig. 2 and Fig. 3 where respectively represent the turn-on and turn-off state of the switch. In this situation, S_1 is turned on for T_1 interval and off for T_2 interval by the PWM control signal of a certain duty ratio, and D_1 is reverse-biased; S_2 is fully turned off and D_2 is forward-biased to maintain the current flow. The switch control strategies will be discussed in section III and IV.

T_1 interval: the current flows from battery 1 to inductor L through S_1 as shown in Fig. 2. The energy is stored in inductor temporarily.

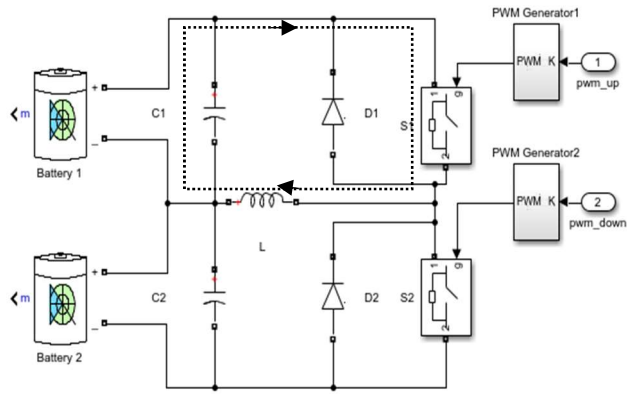

Fig. 2. battery 1 discharges inductor

T_2 interval: the current of L keeps the previous direction, as shown in Fig. 3 which forms a loop; $L \rightarrow$ battery 2 $\rightarrow D_2 \rightarrow L$. So the excess charge successfully transfers from overcharged battery 1 to the undercharged battery 2 at the end of T_2 .

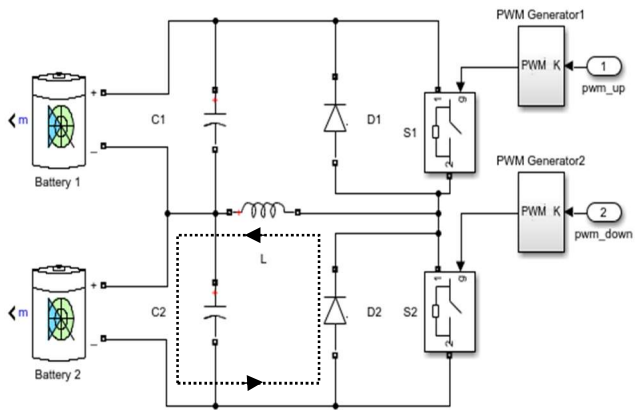

Fig. 3. inductor charges battery 2

Capacitor is used for temporary storage to suppress the high frequency fluctuation in current due to the fast switching of the converter. Its capacitance is chosen to be sufficiently large to achieve this objective but not too large to affect the battery response.

B. Four batteries system

The control scheme and system circuit topology can be applied to multi-battery system. For simplicity, only four batteries are presented here. Each battery is connected to one converter as discussed above. The operation of converters follows the proposed algorithms.

Take battery 1 as the upper end battery and battery 4 as the lower end battery. Given that two switches of the same converter cannot be turned on simultaneously, each converter has three operation modes:

Mode 0 : Both upper and lower switches are turned off. In this case, the converter is fully turned off and not used.

Mode 1 : Upper switch is turned on with a given duty ratio while lower switch is turned off. In this case, excess charge transfers from upper batteries to lower batteries.

Mode 2 : Upper switch is turned off while lower switch is turned on with a given duty ratio. In this case, excess charge transfers from lower batteries to upper batteries.

Fig. 4 and Fig. 5 shows the current flow in 'on' state and 'off' state when converter 1 and converter 4 are both in **Mode 1**.

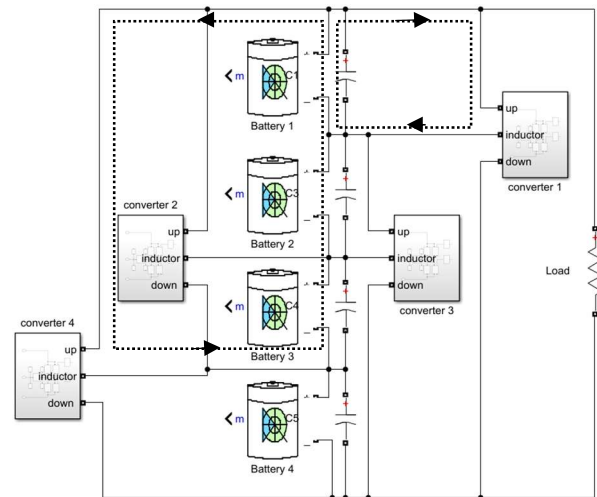

Fig. 4. 'on' state

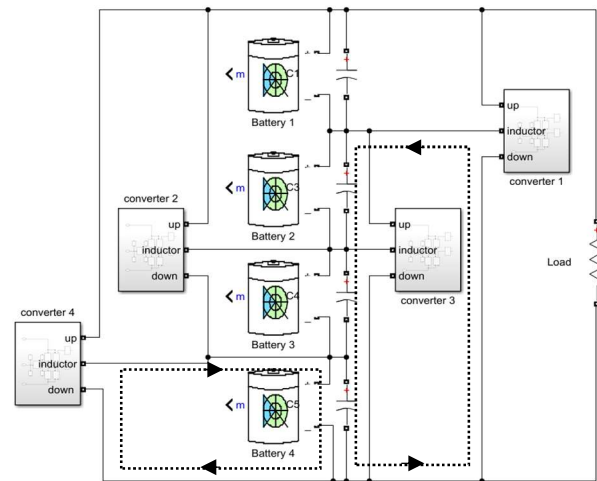

Fig. 5. 'off' state

If converter 1 is in **Mode 1**, upper switch turns on and off with a given duty ratio and lower switch is turned off all the time. In this case, battery 1 charges inductor at 'on' state of switch. And inductor then discharges to battery 2, battery 3 and battery 4 at 'off' state. In such a period, energy transfers from battery 1 to other batteries. At the same time, if converter 4 is in **Mode 1**, energy transfers from battery 1, battery 2 and battery 3 to battery 4. In this example, battery 1 only discharges so energy is removed to other batteries. And battery 4 is only charged by other batteries so it receives the most quantity of energy. Battery 2 and battery 3 experience both charge and discharge so they are balanced simultaneously.

III. CONTROL SCHEME

A. Switch selection algorithm

To switch between three modes described above, a selection algorithm is proposed. To achieve that, the SOC of all batteries are measured firstly. The SOC is measured by the current integration method:

$$SOC = SOC_0 + \frac{\int i dt}{Q_n} \quad (1)$$

Where SOC_0 is the initial SOC value of battery, and i is the current of the battery, and Q_n is the rated capacity of battery [13]. The real time SOC value is obtained by summation of the ratio of current integration to the battery capacity. Though this paper only considers this straightforward method while focusing mainly on the regulation of the converters' operations and the control on the voltage, more comprehensive SOC measurement methods like Combined Coulomb Counting and Fuzzy Logic Method [14] can be applied in practice.

The average SOC is calculated from the initial SOC of all batteries, which is only calculated once during the whole process. Every time when real time SOC of all batteries are updated, the ones having the maximum and minimum SOC are noted. According to this information, their corresponding converters (i.e. those across the most overcharged and undercharged batteries) are turned on while the others are not used. The flow chart for selection algorithm of n batteries system is given in Fig. 6.

$SOC = \{soc_1, soc_2, \dots, soc_n\}$ denotes a set of SOC of all batteries; $\mathbf{Y} = \{y_1, y_2, \dots, y_n\}$ denotes a set of state of all converters, which will be initialized to $\{0, 0, \dots, 0\}$ at the beginning; n is the number of batteries. The error value will be explained further in PWM duty ratio adjusting algorithm.

This algorithm divides the battery string into two parts, namely upper set and lower set. For batteries in upper set, **Mode 1** is the state when upper batteries charge lower batteries. And **Mode 2** is the state when batteries in lower set charge batteries in upper set. For batteries in lower set, **Mode 2** is the state when upper batteries charge lower batteries. And **Mode 1** is the state when lower batteries charge upper batteries. For both groups, **Mode 0** means converters are fully turned off.

To clarify that in four batteries system, '1001' means battery 1 is the most overcharged one while battery 4 is the most undercharged one. And the balancing circuits work as depicted in Fig. 4 and Fig. 5.

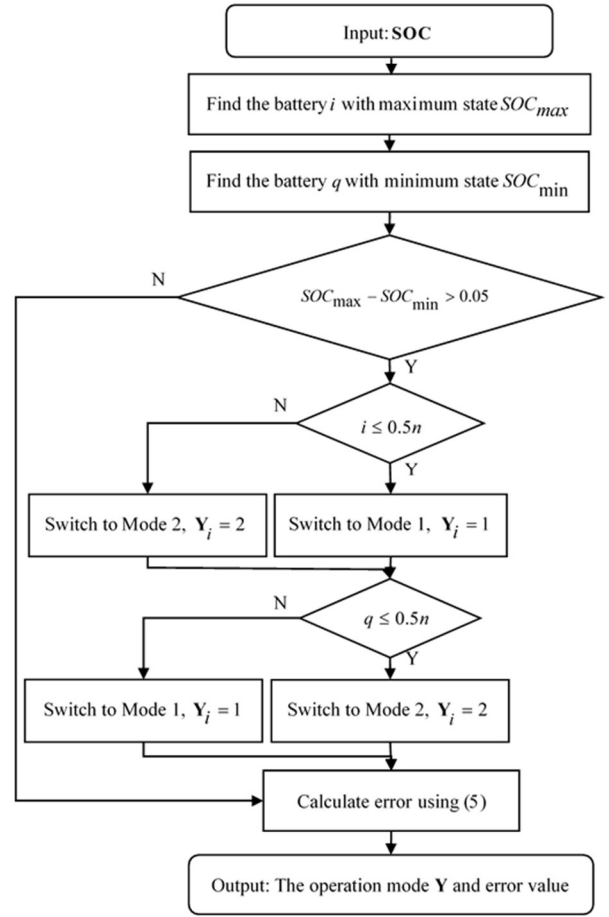

Fig. 6. Switch selection algorithm flow chart

B. PWM duty ratio adjusting algorithm

When the inductor is charged, the voltage is given as:

$$v = L \frac{di}{dt} \quad (2)$$

To guarantee the discontinuous mode, which means all the energy stored in inductor is transferred to battery, the current should decrease to zero [12]. So the duty ratio is obtained:

$$\frac{v_1}{L} \cdot \frac{D}{f_s} < \frac{v_2}{L} \cdot \frac{1-D}{f_s} \quad (3)$$

$$D < \frac{v_2}{v_1 + v_2} \quad (4)$$

In (3), v_1 is the voltage of charging battery and v_2 is the voltage of discharging battery. D is the duty ratio. During the dynamic process, the voltage of batteries fluctuate all the time. Duty ratio cannot be determined solely from this equation. Even if duty ratio is set to a certain value, such fixed value does not meet fast equalizing requirement. Hence PI controller is used to adjust the real time duty ratio. Voltage of battery is not continuously increasing or decreasing because it is affected by many factors such as ripple and load current. Because of its unpredictable responses, the voltage itself cannot be used by the PI controller for duty ratio adjustment.

SOC, as the root cause of cell imbalance, will increase when battery charges and decrease when battery discharges. It is then a suitable parameter as input to the above PI-based control system. For the purpose of SOC balancing, the reference is average value of SOC and the input is the minimum value of SOC. So the SOC error is calculated as:

$$SOC_{error} = \overline{SOC} - SOC_{min} \quad (5)$$

The duty ratio is the output of PI controller. If SOC serves as the input, the duty ratio will keep on increasing to speed up the balancing process. However, due to the integral operation of PI controller, the duty ratio will rise to a relatively high value and maintain such value until balancing process stops. Under such high duty ratio, the operating points of the battery voltages will move far away from their nominal levels.

To prevent this side effect, voltage difference is taken as the detuning parameter to slow down the increasing speed of duty ratio. The instant voltage of all batteries are measured and the maximum value and minimum value are found. The voltage difference is defined as:

$$v_{diff} = v_{max} - v_{min} \quad (6)$$

The voltage difference is multiplied by a detuning factor and is used to re-adjust the final input of PI controller.

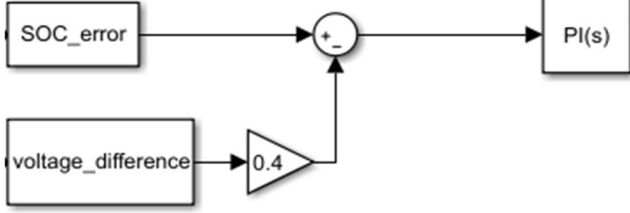

Fig. 7. PI controller

Therefore, the input to the PI controller can be obtained as

$$u(t) = i(t) + p(t) \quad (7)$$

where

$$p(t) = K_p \cdot (SOC_{error} - K_v \cdot v_{diff}) \quad (8)$$

and

$$i(t) = K_i \cdot \int_0^t (SOC_{error} - K_v \cdot v_{diff}) \cdot dt \quad (9)$$

K_p is the overall proportional gain, K_v is the detuning factor (set to 0.4 here), and K_i is the integral gain. The output of the PI controller is the converter's duty ratio adjusted considering the need for SOC balancing and minimisation in battery voltage fluctuation, and this duty ratio information is transferred as an input to the switch controlling algorithm as described below.

C. Switch controlling algorithm

This algorithm generates two values for PWM input of one converter; respectively to its upper and lower switches. Referring to Fig. 1, the upper switch is supplied with `pwm_up` port signal while the lower switch by `pwm_down` port.

Algorithm3 The Switch controlling Algorithm

1. **Input:** state, D
2. **Output:** PWM_1 , PWM_2
3. Initialize PWM_1 and PWM_2
4. **if** state = 0
5. $PWM_1 = 0$, $PWM_2 = 0$
6. **elseif** state = 1
7. $PWM_2 = 0$, $PWM_1 = D$
8. **elseif** state = 2
9. $PWM_2 = D$, $PWM_1 = 0$
10. **end if**

IV. SYSTEM DESIGN

A. System control algorithm

This is the overall system algorithm, which combines all the control algorithms in section III. The duty ratio of converter can be updated continuously until all batteries achieve SOC balancing. $SOC = \{soc_1, soc_2, \dots, soc_n\}$ and $V = \{v_1, v_2, \dots, v_n\}$ denote a set of real time state and voltage of all batteries respectively. The control loop continues until the range of SOC is less than a given threshold.

Algorithm4 The SOC-voltage Control Algorithm

1. Measure the set of **SOC** and the set of voltage **V**
2. Initialize all converters to **Mode 0**
3. **While** $SOC_{max} - SOC_{min} > 0.05$ do
4. Compute SOC error using (5)
5. Compute voltage difference using (6)
6. Obtain duty ratio from PI controller
7. Call Switch Selection Algorithm to obtain switch state
8. Call Control Switch Algorithm to obtain input of PWM generator
9. Update PWM duty ratio of converter
10. **end while**

The system control model can be constructed in Simulink. Fig. 8 considers converter 1 as an example. It displays all the associated control schemes of converter 1 while other ports are to be connected to other converters.

It is worth mentioning that an ZOH is placed between mode output (i.e. $y_1 \sim y_4$) and state input. This is because that converter detects change of state once a given period rather than continuously. ZOH block can help keep the previous state until next change occurs. This reflects on the actual operation setup in hardware design where such detection scheme can save power consumption by a microcontroller and avoids the continuous execution of the switch selection algorithm. In addition, saturation block can limit the duty ratio between 0 and the upper operating limit of a buck-boost converter.

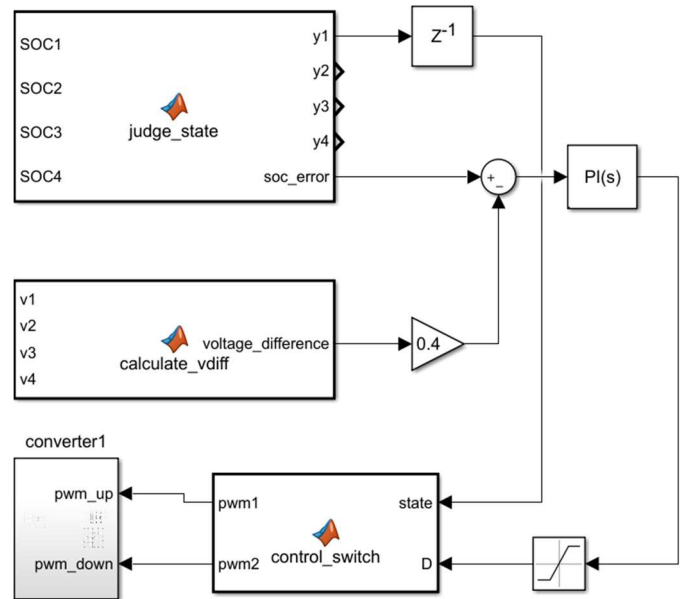

Fig. 8. system model

V. SIMULATION & DISCUSSION

A. Settings

Four batteries have the same capacities and nominal voltages but different SOC. For the sake of simulation time, the difference between SOC is selected to be small and so are their capacities. The load resistance is large so that only a small amount of current is drawn continuously by the load from the batteries.

TABLE 1
SIMULATION PARAMETERS

Simulation Parameters	Values
SOC_1	65%
SOC_2	64.8%
SOC_3	64.6%
SOC_4	64.4%
capacity	0.54Ah
Nominal voltage	7.2V
Inductor (L)	1mH
Capacitor ($C_1 C_2 C_3 C_4$)	10uF
Load (R)	1k Ω

B. Simulation results

The simulation results compare two different methods: the proposed SOC-voltage control method and control scheme with only SOC. The only difference between them is that the latter one does not introduce voltage as detuning parameter.

Fig. 9 shows that before equalization, the balancing rate of each SOC line changes all the time following the duty ratio adjusting algorithm. At $t = 27s$, the SOC of four batteries achieve approximately the same (with the range less than 0.05%). It can be seen from the graph that when battery 4 has surpassed battery 3 in SOC, the switch selection algorithm can readjust the duty ratio and switching state by assuming battery 3 as the most undercharged one.

However, Fig. 10 shows that in a same simulation time, the control scheme with only SOC cannot regulate SOC efficiently. It will take more time for batteries to achieve equalization.

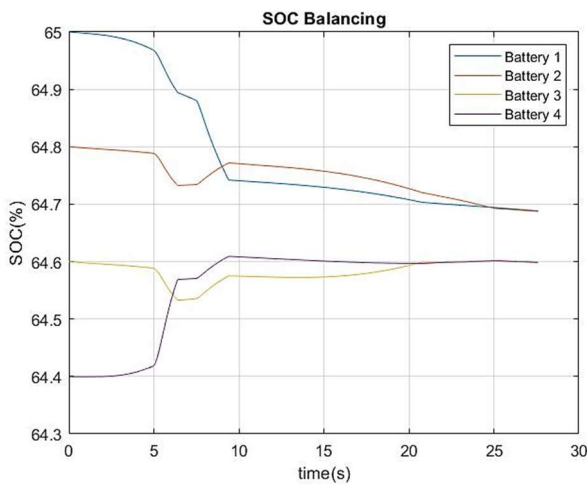

Fig. 9. SOC response using the proposed SOC-voltage control method

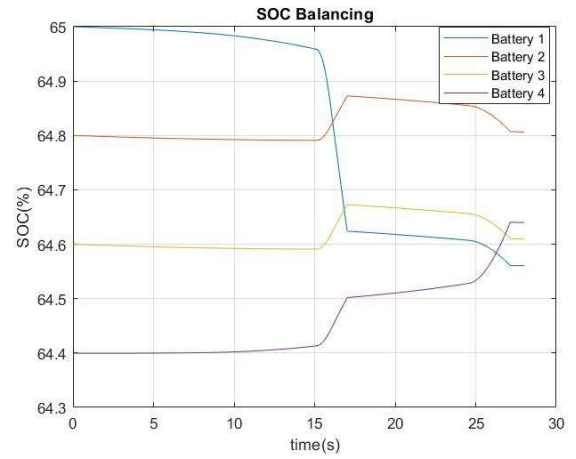

Fig. 10. SOC response using only SOC control method

Fig. 11 shows the voltage change of four batteries under proposed control scheme. As balancing process begins, the voltage range becomes larger. But due to the voltage difference compensation in PI controller, the voltage range will become smaller as time goes on. Unlike voltage-based balancing method, this soc-based method focuses on the final state of battery system. At the end, the voltage of all batteries will achieve the same because their SOC have equalized. Fluctuations may occur during the balancing process but they are tolerable because the control scheme minimizes them. However, if only SOC is considered in the duty ratio adjusting algorithm, the voltage fluctuation will be very large as shown in Fig. 12, especially during 15~17s.

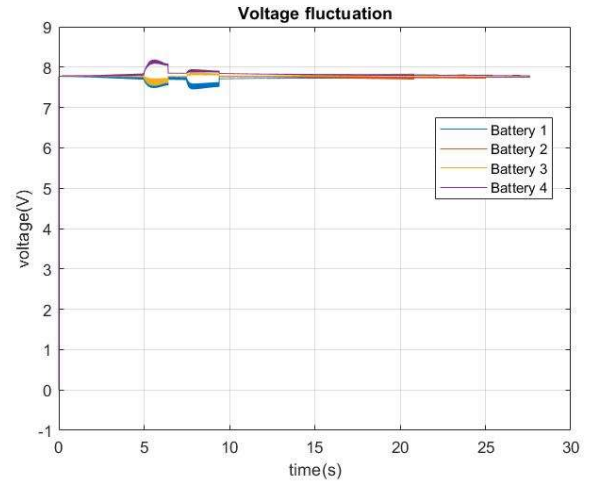

Fig. 11. Battery voltage response using the proposed SOC-voltage control method

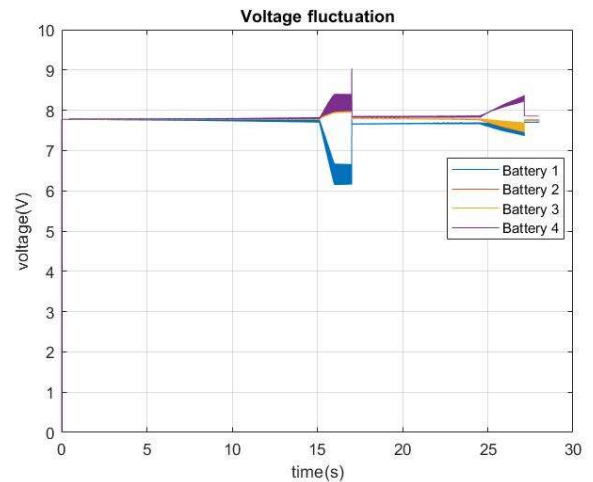

Fig. 12. Battery voltage response using only SOC control method

VI. CONCLUSION

The fixed duty ratio method is not considered here because it is impossible to find the best duty ratio by adjusting the value manually, especially for multi-battery system. However, choosing a value randomly will cause many problems. There will be either too much voltage fluctuation or too long balancing time. Even worse, battery may suffer from overbalance or underbalance. This control scheme ensures that the system has both fast balancing speed and small voltage fluctuation by adjusting the duty ratio automatically.

Fig. 13 and Fig. 14 explain it in further. During the balancing process, the largest load voltage ripple for proposed method is less than 3%. After balancing, the load becomes stable. However, the control scheme with only SOC suffers up to 15% load voltage ripple. There is also an instant spike at $t = 17s$, which may even do harm to the output electrical equipment. Therefore, this comparison also shows that the proposed method has advantages in reducing load ripple.

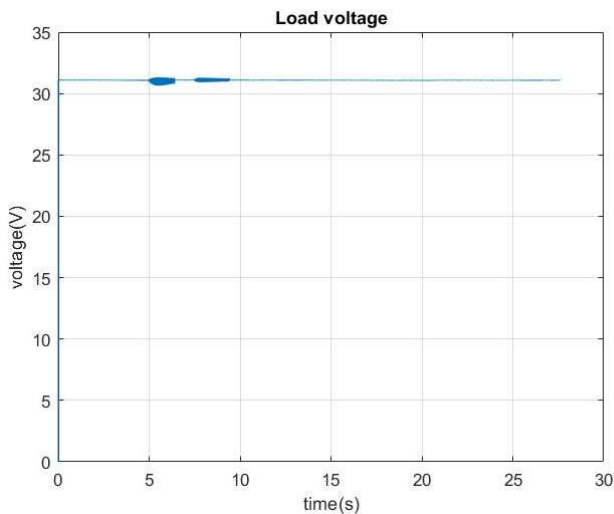

Fig. 13. Load voltage response using the proposed SOC-voltage control method

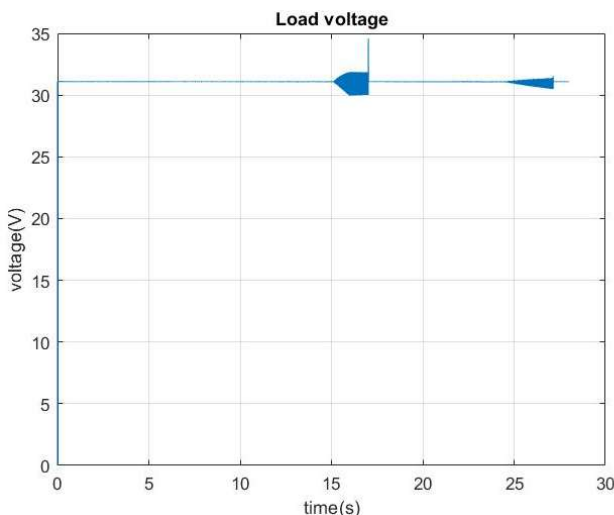

Fig. 14. Load voltage response using only SOC control method

This paper applies buck-boost converter for equalizer. The principle of single balancing circuit as well as system equalizer is presented. The proposed control scheme is composed of switch selection algorithm, PWM duty ratio adjusting algorithm and switch controlling algorithm. And the key feature of this scheme is the combined SOC and voltage regulation for a single goal in achieving battery equalisation. Simulation results have shown that batteries can achieve equalization both in SOC and voltages. The control of the former remains the main loop of the scheme while the fluctuation of the latter is minimized through a detuning loop. The overall balancing is achieved, and as expected it has delivered faster response with less voltage disturbance as compared to the scheme with only SOC control. The power transferred to the load is hardly affected. This control method has the potential to be extended for systems with multiple lithium-ion batteries so that SOC of all batteries will converge at the end..

REFERENCES

- [1] Lawder M, Suthar B, Northrop P, et al. Battery Energy Storage System (BESS) and Battery Management System (BMS) for Grid-Scale Application[J]. *Proceedings of the IEEE*, 2014, 102(6): 1014-1030.
- [2] Guo, X. Study on State of Charge Estimation and Equalization Technique of Electric Vehicle Battery. Ph.D. Thesis, South China University of Technology (SCUT), Guangzhou, China, 2016.
- [3] Tan, X. Battery Management Systems on Power Batteries: Applied Technology and Advanced Theories; Zhongshan University Press: Guangzhou, China, 2014; pp. 79–108.
- [4] M. Daowd, N. Omar, P. Van Den Bossche and J. Van Mierlo, "Passive and active battery balancing comparison based on MATLAB simulation," 2011 IEEE Vehicle Power and Propulsion Conference, Chicago, IL, 2011, pp. 1-7.
- [5] K. Vitols, "Redesign of passive balancing battery management system to active balancing with integrated charger converter," 2014 14th Biennial Baltic Electronic Conference (BEC), Tallinn, 2014, pp. 241-244, doi: 10.1109/BEC.2014.7320601.
- [6] W. Hong, K. Ng, J. Hu and C. Moo, "Charge equalization of battery power modules in series," The 2010 International Power Electronics Conference - ECCE ASIA -, Sapporo, 2010, pp. 1568-1572.
- [7] J. V. Barreras, C. Pinto, R. de Castro, E. Schartz, S. J. Andreasen and R. E. Araujo, "Multi-Objective Control of Balancing Systems for Li-Ion Battery Packs: A Paradigm Shift?," 2014 IEEE Vehicle Power and Propulsion Conference (VPPC), Coimbra, 2014, pp. 1-7.
- [8] Y. Barsukov, "Battery cell balancing: What to balance and how," Texas Instruments.
- [9] B. Yevgen and J. Q., Cell-balancing techniques: theory and implementation. *Battery Power Management for Portable Devices*, Norwood, MA, Artech House, 1 May 2013, pp. 111-138.
- [10] Y. Yang, Z. Zhang, D. Gu and X. Cheng, "Balancing strategy of lithium-ion batteries based on change rate of SOC," 2017 IEEE Applied Power Electronics Conference and Exposition (APEC), Tampa, FL, 2017, pp. 3223-3228.
- [11] H. Pai, K. Ho, G. Chen, P. Liao, S. Wang and Y. Liu, "An SOC-based Active Equalizer for Fast Charge Balance of Series-Connected Battery Pack," 2020 IEEE 29th International Symposium on Industrial Electronics (ISIE), Delft, Netherlands, 2020, pp. 655-659.
- [12] Shubiao Wang, Longyun Kang, Xiangwei Guo, Zefeng Wang and Ming Liu, Novel Layered Bidirectional Equalizer Based on a Buck-Boost Converter for Series-Connected Battery Strings, *Energies*, July.2017.
- [13] X. Liu, Z. Gao, X. Huang and Y. Zou, "Large Equalization Current Control Strategy for Series Connected Battery Packs Based on Buck-Boost Converter," 2018 International Power Electronics Conference (IPEC-Niigata 2018 -ECCE Asia), Niigata, 2018, pp. 3455-3459.
- [14] D. Saji, P. S. Babu and K. Ilango, "SoC Estimation of Lithium Ion Battery Using Combined Coulomb Counting and Fuzzy Logic Method," 2019 4th International Conference on Recent Trends on Electronics, Information, Communication & Technology (RTEICT), Bangalore, India, 2019, pp. 948-952.