



Deposited via The University of Sheffield.

White Rose Research Online URL for this paper:

<https://eprints.whiterose.ac.uk/id/eprint/167402/>

Article:

Mou, X., Gladwin, D.T., Zhao, R. et al. (2020) Coil design for wireless vehicle-to-vehicle charging systems. IEEE Access, 8. pp. 172723-172733. ISSN: 2169-3536

<https://doi.org/10.1109/access.2020.3025787>

Reuse

This article is distributed under the terms of the Creative Commons Attribution (CC BY) licence. This licence allows you to distribute, remix, tweak, and build upon the work, even commercially, as long as you credit the authors for the original work. More information and the full terms of the licence here:

<https://creativecommons.org/licenses/>

Takedown

If you consider content in White Rose Research Online to be in breach of UK law, please notify us by emailing eprints@whiterose.ac.uk including the URL of the record and the reason for the withdrawal request.

Received August 17, 2020, accepted August 27, 2020, date of publication September 22, 2020, date of current version October 1, 2020.

Digital Object Identifier 10.1109/ACCESS.2020.3025787

Coil Design for Wireless Vehicle-to-Vehicle Charging Systems

XIAOLIN MOU¹, (Member, IEEE), DANIEL T. GLADWIN¹, (Senior Member, IEEE),
RUI ZHAO¹, HONGJIAN SUN², (Senior Member, IEEE), AND ZHILE YANG³, (Member, IEEE)

¹Department of Electronic and Electrical Engineering, The University of Sheffield, Sheffield S1 3JD, U.K.

²School of Engineering, Durham University, Durham DH1 3DE, U.K.

³Shenzhen Institutes of Advanced Technology, Chinese Academy of Sciences, Shenzhen 518000, China

Corresponding author: Zhile Yang (zl.yang@siat.ac.cn)

This work was supported in part by the National Natural Science Foundation of China under Grant 52077213, Grant 62003332, and Grant 61673256; in part by the National Natural Science Foundation of Guangdong under Grant 2018A030310671; and in part by the Outstanding Young Researcher Innovation Fund of Shenzhen Institute of Advanced Technology, Chinese Academy of Sciences, under Grant 201822.

ABSTRACT Electric Vehicles (EVs) are seeing increasing worldwide adoption, largely due to their reduced greenhouse gas emissions and reliance on hydrocarbons. Slow advances in battery technology are one of major factors restricting the development of EVs. Many customers worry that their EV may run out of power during a journey, especially in colder climates. This paper proposes a vehicle-to-vehicle (V2V) charging system that works together with charging plug-in EVs, or operates independently. The new V2V charging technology helps to address problems due to a limited number of plug-in stations, as well as to reduce the risk of an EV running out of power during a journey. A novel transmitter coil structure is proposed for wireless V2V charging, to address issues caused by angular offset between the transmitting and receiving EV. Simulation results show that the novel transmitter coil structure is able to generate a stronger magnetic field than benchmark transmitter coils. An experimental prototype has been built for evaluation. Compared with the benchmark transmitter coil constructed from the same amount of materials, the novel transmitter coil structure offers more than 10 percent of efficiency improvement, which demonstrated by the 90% efficiency prototype.

INDEX TERMS Vehicle to vehicle (V2V) charging, wireless charging, angular offset, power transfer efficiency.

I. INTRODUCTION

Interest in renewable energy generation and electric vehicles (EVs) has increased in recent years due to growing concerns over climate change, air pollution, and energy security [1]. Automotive manufacturers have developed various types of EVs, such as pure battery EVs and hybrid EVs. The slow rate of progress in electrical energy storage technology is a key issue that is restricting EV development. The design of electrical energy storage systems for EVs is complex due to the EV's need for high energy density, low cost, a long lifetime, and many other requirements [1].

Currently, there are two methods used to charge EVs: plug-in charging, and wireless charging, with most EVs currently relying on the former. Plug-in charging can provide high charging efficiency. However, there are various

downsides to plug-in charging, such as the charging cables presenting a potential trip hazard, the inconvenience of having to physically insert and remove the charger, and degradation of the charger cables over time, potentially creating a hazard to the user [2]. Wireless charging can help to address these problems and it also can work together with monitoring systems [3]–[5]. A regulatory and consumer-led insistence on greater levels of safety and convenience has prompted an ever-growing demand for wireless power transfer (WPT). In 2014, Plugless Power began offering WPT kits for the Chevy Volt, Nissan LEAF, and Cadillac ELR. The power levels can achieve: 3.7kW (WPT 1), 7.7kW (WPT 2), 11kW (WPT 3). In recent years, Plugless has expanded its offering to include the BMW i3, Mercedes S550e, and Tesla Model S [6], [7].

Although governments, such as the UK, have created various incentives to encourage EV adoption, e.g. through tax breaks on the purchase of EVs and the Charging

The associate editor coordinating the review of this manuscript and approving it for publication was Bin Zhou ¹.

Infrastructure Investment Fund [8], many consumers are still reluctant to purchase pure battery EVs. There are a number of causes for this trepidation, key amongst them being anxiety over the potential need to recharge the vehicle during a journey. The number of plug-in charging stations is limited and may not be conveniently located relative to a user's route, especially when compared to the ease of locating a petrol station. A further issue may then arise where the user has located a charging station, only to find that all charging slots are already occupied. Vehicle-to-Vehicle (V2V) charging technology can provide a good solution to the above problems.

A number of works propose to investigate V2V charging strategies [9]–[18]. Liu *et al.* [11] mentions a framework for V2V charging. When EVs are connected to the power grid for charging and/or discharging, they become gradable EVs (GEVs). This paper researches the relationship between the EVs as GEVs in V2V and smart grid. Zhang *et al.* [12] present a flexible energy management protocol for cooperative EV-to-EV charging, which can help the EVs achieve improved charging/discharging behaviors. Even taking the potential cost (e.g., the battery lifetime loss) into consideration, there is still a profit margin for EVs as energy providers to achieve cooperative V2V charging based energy trading with their stored low-cost surplus power. Abdolmaleki *et al.* [14] proposed an energy trading method based on dynamic programming solution methodology to analysis the impact of adopting wireless V2V technology in terms of system-wide energy savings, charging infrastructure requirements, and travel times, and investigate the possibility of reducing battery capacity in EVs. Li *et al.* [13] proposed an intelligent vehicle-to-vehicle charging navigation for mobile electric vehicles via VANET-Based Communication. Sousa *et al.* [16] present a direct on-board DC V2V method, using only two conversions (DC-DC, DC-DC), potentially increasing the overall efficiency of power transfer between EVs and reducing the weight of devices in V2V.

Magnetic resonant coupling WPT technology is well suited for use in wireless EV charging due to this technology's safety and high power transfer efficiency (PTE) over a long transmit distance [3], [19], [20]. Conventional wireless EV charging systems include a transmitter coil, which is embedded in the floor of the charging area, and a receiver coil, which is embedded in the vehicle's chassis. The transmitter coil connects to the power supply (grid or storage), and the receiver coil connects to the vehicle's battery. In this case, the key factors affecting PTE are the distance between the lateral misalignment, and the angular misalignment is ignored [21], [22]. Another potential misalignment is the introduction of an angular offset, which is especially relevant in wireless V2V charging due to the positioning of the resonant coils in the front and rear of the vehicle. Some analysis of angular offset has been undertaken in previous research. Angular offset significant reduces PTE in wireless charging systems [23]–[25]. J. Chow *et al.* present a structure that comprises two windings located in an orthogonal arrangement,

lessening variation of the coupling coefficient due to coil lateral and angular misalignment [26]. Another issue in wireless EV charging is the choice of resonant coil size. Kavitha [27] show that increasing the receiver coil size can reduce magnetic flux leakage, thereby increasing PTE. W. Zhang *et al.* show that a larger receiver coil can improve the coupling coefficient when two resonant coils have misalignment [28].

Compared with internal combustion engine vehicles, the limited driving range and the long charging time of electric and plug-in hybrid vehicles cause 'range anxiety' among existing owners while posing barriers to market adoption by potential new owners [29]. Lee presented that journeys over 300 miles will require at least one charging station, using Tesla Supercharger to completely 300 miles would take about 45 minutes. Further, in areas with charging station congestion or stations where customers typically leave their car to charge while they do something else (shopping for example), there may be an additional delay waiting for a space to open up [30]. Utilizing the proposed wireless V2V charging system, multi vehicles can be charged from a single wireless V2V charging system, which addresses the availability issues from the limited numbers of plug-in charging stations. furthermore, a car equipped with wireless V2V charging technology could be used a rescue vehicle hence perform auxiliary charging in urgency scenario. Besides, compared with typical wireless magnetic resonant coupling EV charging technology, angular offset is a more significant problem in V2V applications, due to the positioning of the resonant coils in the front and rear of the vehicle. Considering the rounded shape of the front of a typical car, this article proposes a triangular transmitter design capable of improving charging efficiency when the resonant coils are operating at an angular offset.

The summary contributions of this paper are as follows:

- 1) We proposed the detail framework and scenarios of wireless V2V charging technology which can effective sole the 'range anxiety' among existing owners. Expansion of the EVs market, especially potential consumers. The proposed wireless V2V charging system is not only an implementation of engineering technology but also a new energy and electricity market transaction. The EVs users can earn revenue through this energy trading.
- 2) Both wireless charging and wired charging can be realised in a V2V charging system. Considering the convenience of EVs consumers, this paper focuses on wireless V2V charging technology. We proposed a new triangular transmitter coil structure in the wireless V2V charging system.
- 3) Angular misalignment is ignore in traditional wireless EVs charging due to the resonant coil position in the car's chassis, however, it can not be ignored in the wireless V2V charging system. This paper gave an analysis of angular misalignment and provide a triangle-shaped transmitter coil to solve the angular misalignment thus improve the power transfer efficiency.

Section II introduces the framework of this wireless V2V charging system. Section III provides a theoretical analysis of a multi-turn coil with an angular offset in a WPT system. Section IV presents the structure of the proposed transmitter and an existing benchmark transmitter, both are compared using a CST *H*-field simulation and a hardware implementation.

II. WIRELESS V2V CHARGING SYSTEM FRAMEWORK

The framework of V2V charging system, as shown in Fig. 1. There are two scenarios of V2V charging system: Plug-in with wireless V2V charging system and Vehicle assistant wireless charging system.

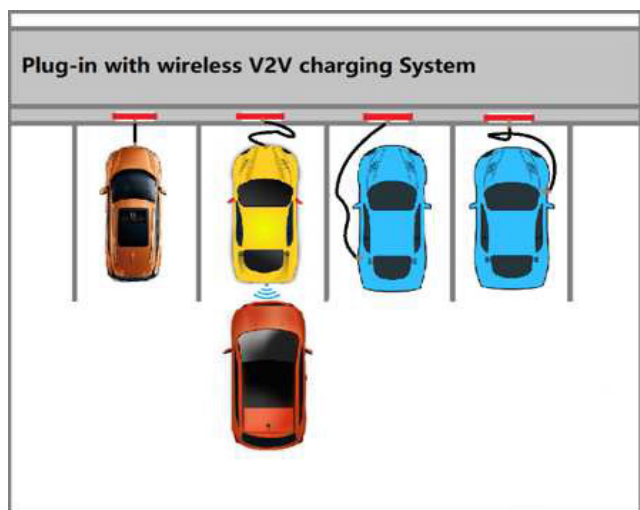

(a) Plug-in with wireless V2V charging system

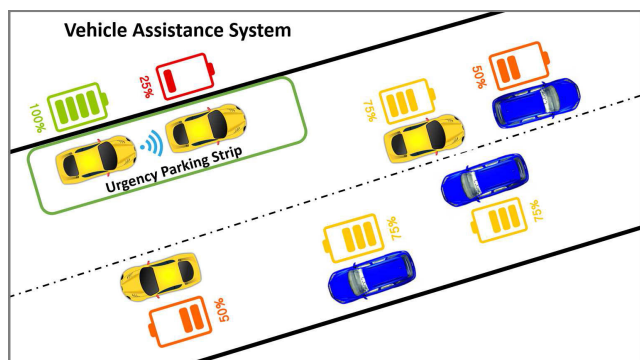

(b) Vehicle assistance wireless V2V charging system

FIGURE 1. Framework of Wireless V2V charging system.

A. PLUG-IN WITH WIRELESS V2V CHARGING SYSTEM

Fig. 1a shows the structure of the combined plug-in and wireless V2V charging system. The transmitter and the receiver coils are embedded in the front and rear of the car respectively. If there are insufficient charging points the first car can automatically wirelessly charge the car behind it. This is useful, as with increasing numbers of EVs the biggest drawback of plug-in charging systems is the limited number

of charging stations. Addressing this by simply increasing the quantity of charging points requires greater investment, and increases maintenance costs. The proposed combined plug-in and wireless V2V charging system can improve utilization of plug-in charging points, and reduces the difficulty of charging when all chargers are found to be occupied. This technology can effectively solve the first EVs that are fully charged but later EVs need to wait for the charging station to open up. The charging agreement communication between the two EVs drivers is necessary which can through drivers’ smartphone APP. The both parties to the transaction must agree to some information sharing, *e.g.* charging time, battery capacity *etc.* In addition, the application is suitable for scenarios of large parking stations and side street parking stations. There is no parking area that will be blocked because this application can not be completed if no parking area.

B. VEHICLE ASSISTANCE WIRELESS CHARGING SYSTEM

Fig. 1b shows the vehicle assistance wireless charging system. When a vehicle’s battery runs low, the driver can request the help of other EVs on the road to wirelessly charge the vehicle. In this process, there are several auxiliary technologies, such as vehicle-to-vehicle communication, GPS, and battery state of charge detection *etc.* The driver can find suitable power supply vehicles using an application on their smart device that indicates available donor vehicle energy, pricing, distance, and other metrics.

This concept can help to alleviate a potential EV purchaser’s concerns around range anxiety. In addition, the supplier EVs have enough electrical energy that can arrive at the destination, and under this premise, the supplier EVs owners can earn revenue through energy arbitrage from every kWh of electricity that is discharged from their vehicle’s ESS to the other vehicle.

III. ANALYSIS OF MULTI-TURN COILS WITH AN ANGULAR OFFSET

A. POWER TRANSFER EFFICIENCY

The power transfer efficiency (PTE) η of a wireless EV charging system can be defined as [21]

$$\eta = \frac{\sqrt{1 + \frac{k^2}{L_T L_R}} - 1}{\sqrt{1 + \frac{k^2}{L_T L_R}} + 1} \tag{1}$$

where L_T and L_R represent the inductance of the transmitter and receiver coils respectively. $k = \frac{M\omega}{2\sqrt{L_T L_R}}$ represents the coupling coefficient between the two resonant coils, ω the resonant frequency, and M the mutual inductance of the transmitter and receiver. There are two important parameters in PTE calculation: the inductance of coil (L) and the mutual inductance between coils (M).

B. INDUCTANCE CALCULATION OF MULTI-TURN COIL

The total inductance L of the coil is equal to the sum of the self-inductance L_S of each straight conductor plus the sum

of the mutual inductances L_M between these conductors. The mutual inductance between the straight conductors L_M can be divided into positive mutual inductance L_{M+} and negative mutual inductance L_{M-} . Positive mutual inductance is the mutual inductance between conductors that have the same current direction. Negative mutual inductance is the mutual inductance between conductors that have opposing current directions. The total inductance L of the coil can be defined as [17], [31]:

$$L = L_S + L_{M+} - L_{M-} \quad (2)$$

The self-inductance of a straight conductor L_{S_i} [32]:

$$L_{S_i} = 0.002 \cdot l_i \cdot \left\{ \ln\left(\frac{l_i}{r}\right) + 0.50049 + \frac{2r}{3l_i} \right\} \quad (3)$$

where l_i denotes the length of the conductor in centimeters (each straight segment of the coil, i denote the number of straight segment), and r the diameter of the conductor in centimeters. As shown in Fig. 2a-A, the total self-inductance of the coil is $L_S = L_{S1} + L_{S2} + L_{S3} + \dots + L_{S16}$.

The mutual inductance of the straight conductors L_{M_i} [33]:

$$L_{M_i} = 2 \cdot l_i \cdot F_i \quad (4)$$

where F_i the mutual inductance parameter calculated as [33]:

$$F_i = \ln\left\{\left(\frac{l_i}{d}\right) + \left[1 + \left(\frac{l_i}{d}\right)^2\right]^{\frac{1}{2}}\right\} - \left[1 + \left(\frac{l_i}{d}\right)^2\right]^{\frac{1}{2}} + \left(\frac{d}{l_i}\right) \quad (5)$$

where d is the distance between two conductors. The diagram of the mutual inductance between two conductors is shown in Fig. 2a-B, where g and h specify particular conductors, and p and q denote the difference in length between the two conductors.

$$M_{g,h} = \frac{1}{2} \{ (M_{h+p} + M_{h+q}) - (M_p + M_q) \} \quad (6)$$

The mutual inductance of two conductors is maximized if the two conductors are in parallel, and is minimized if they are arranged orthogonally, so for the four-turn spiral coil positive mutual inductance is defined as

$$\begin{aligned} L_{M+} = & 2(L_{M_{1,5}} + L_{M_{1,9}} + L_{M_{1,13}}) \\ & + 2(L_{M_{5,9}} + L_{M_{5,13}}) + 2(L_{M_{9,13}}) \\ & + 2(L_{M_{3,7}} + L_{M_{3,11}} + L_{M_{3,15}}) \\ & + 2(L_{M_{7,11}} + L_{M_{7,15}}) + 2(L_{M_{11,15}}) \\ & + 2(L_{M_{2,6}} + L_{M_{2,10}} + L_{M_{2,14}}) \\ & + 2(L_{M_{6,10}} + L_{M_{6,14}}) + 2(L_{M_{10,14}}) \\ & + 2(L_{M_{4,8}} + L_{M_{4,12}} + L_{M_{4,16}}) \\ & + 2(L_{M_{8,12}} + L_{M_{8,16}}) + 2(L_{M_{12,16}}) \end{aligned} \quad (7)$$

and negative mutual inductance is defined as

$$\begin{aligned} L_{M-} = & 2(L_{M_{1,3}} + L_{M_{1,7}} + L_{M_{1,11}} + L_{M_{1,15}}) \\ & + 2(L_{M_{5,3}} + L_{M_{5,7}} + L_{M_{5,11}} + L_{M_{5,15}}) \\ & + 2(L_{M_{9,3}} + L_{M_{9,7}} + L_{M_{9,11}} + L_{M_{9,15}}) \\ & + 2(L_{M_{13,3}} + L_{M_{13,7}} + L_{M_{13,11}} + L_{M_{13,15}}) \end{aligned}$$

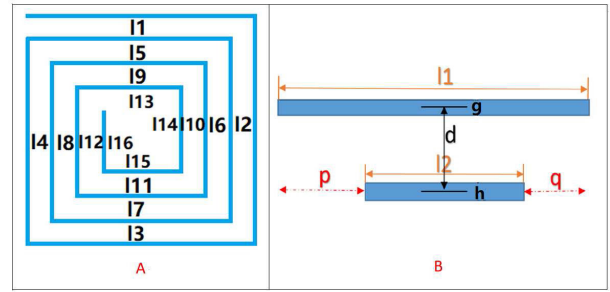

(a) Diagram of mutual inductance between two conductors

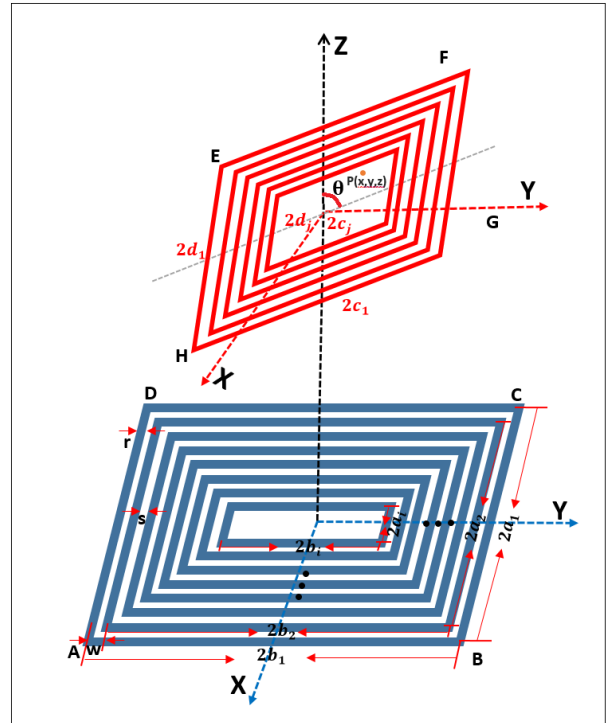

(b) Diagram of multi-turn coil with angular offset

FIGURE 2. Diagram of resonant coils with angular offset in WPT system.

$$\begin{aligned} & + 2(L_{M_{2,4}} + L_{M_{2,8}} + L_{M_{2,12}} + L_{M_{2,16}}) \\ & + 2(L_{M_{6,4}} + L_{M_{6,8}} + L_{M_{6,12}} + L_{M_{6,16}}) \\ & + 2(L_{M_{10,4}} + L_{M_{10,8}} + L_{M_{10,12}} + L_{M_{10,16}}) \\ & + 2(L_{M_{14,4}} + L_{M_{14,8}} + L_{M_{14,12}} + L_{M_{14,16}}) \end{aligned} \quad (8)$$

C. MUTUAL INDUCTANCE BETWEEN TRANSMITTER AND RECEIVER WITH AN ANGULAR OFFSET

Fig. 2b shows a diagram of two multi-turn resonant coils with an angular offset. ABCD denotes the multi-turn transmitter coil and EFGH the multi-turn receiver coil. a_i and b_i indicate the half-width and half-length of the transmitter coil respectively, and c_j and d_j indicate the half-length and the half-width of the receiver coil respectively. i and j denote the number of turns of each of the coils. r is the diameter of the conductor, s represents the space between two adjacent conductors, $w = s + r$ the distance of track centers between

two adjacent conductors, and a_i is equal to $a_1 - (i - 1)w$. θ represents the angular offset between the transmitter coil and the receiver coil. θ is $\pi/2$ when the two coils in parallel position. $P_{(x,y,z)}$ represents an arbitrary point in the receiver coil.

The magnetic flux ϕ can be calculated as [34]:

$$\begin{aligned} \phi_{X_{AB}} = & \frac{\cos(\theta)\mu_0}{2\pi} \\ & \cdot [\log(\sqrt{(a_i + c_j)^2 + z^2 + (b_i + d_j)^2 + (a_i + c_j)}) \\ & + \frac{b_i + d_j}{z} \cdot \arctan(\frac{(b_i + d_j) \cdot (a_i + c_j)}{z \cdot \sqrt{(a_i + c_j)^2 + z^2 + (b_i + d_j)^2}}) \\ & - \log(\sqrt{(a_i + c_j)^2 + z^2 + (b_i - d_j)^2 + (a_i + c_j)}) \\ & - \frac{b_i - d_j}{z} \cdot \arctan(\frac{(b_i - d_j) \cdot (a_i + c_j)}{z \cdot \sqrt{(a_i + c_j)^2 + z^2 + (b_i - d_j)^2}}) \\ & - \log(\sqrt{(a_i - c_j)^2 + z^2 + (b_i + d_j)^2 + (a_i - c_j)}) \\ & + \frac{b_i + d_j}{z} \cdot \arctan(\frac{(b_i + d_j) \cdot (a_i - c_j)}{z \cdot \sqrt{(a_i - c_j)^2 + z^2 + (b_i + d_j)^2}}) \\ & + \log(\sqrt{(a_i - c_j)^2 + z^2 + (b_i - d_j)^2 + (a_i - c_j)}) \\ & + \frac{b_i - d_j}{z} \cdot \arctan(\frac{(b_i - d_j) \cdot (a_i - c_j)}{z \cdot \sqrt{(a_i - c_j)^2 + z^2 + (b_i - d_j)^2}})] \end{aligned} \quad (9)$$

$$\begin{aligned} \phi_{Z_{AB}} = & \frac{\sin(\theta)\mu_0}{2\pi} \\ & \cdot [\sqrt{(a_i + c_j)^2 + z^2 + (b_i + d_j)^2} \\ & - (b_i + d_j) \cdot \arctan^{-1}(\frac{(b_i + d_j)}{\sqrt{(a_i + c_j)^2 + z^2 + (b_i + d_j)^2}}) \\ & - \sqrt{(a_i + c_j)^2 + z^2 + (b_i - d_j)^2} \\ & + (b_i - d_j) \cdot \arctan^{-1}(\frac{(b_i - d_j)}{\sqrt{(a_i + c_j)^2 + z^2 + (b_i - d_j)^2}}) \\ & - \sqrt{(a_i - c_j)^2 + z^2 + (b_i + d_j)^2} \\ & + (b_i + d_j) \cdot \arctan^{-1}(\frac{(b_i + d_j)}{\sqrt{(a_i - c_j)^2 + z^2 + (b_i + d_j)^2}}) \\ & + \sqrt{(a_i - c_j)^2 + z^2 + (b_i - d_j)^2} \\ & - (b_i - d_j) \cdot \arctan^{-1}(\frac{(b_i - d_j)}{\sqrt{(a_i - c_j)^2 + z^2 + (b_i - d_j)^2}})] \end{aligned} \quad (10)$$

where μ_0 represents the permeability of free space. The magnetic flux ϕ produced by the other three conductors BC, CD and DA can be calculated using the same method as for conductor AB. The total magnetic flux due to the i th coil with unit current is $\phi_{ij} = \phi_{X_{AB}} + \phi_{X_{CD}} + \phi_{Z_{AB}} + \phi_{Z_{BC}} + \phi_{Z_{CD}} + \phi_{Z_{DA}}$, and the mutual inductance between the i th coil with the j th

coil is defined as M_{ij} , where $M_{ij} = \phi_{ij}$. Defining the number of turns of the transmitter and receiver coils as $N1$ and $N2$ respectively, the total mutual inductance M is given by:

$$M = \sum_{i=1}^{N1} \sum_{j=1}^{N2} \phi_{ij} \quad (11)$$

Fig. 3 shows the theoretical calculation result between the mutual inductance M and misalignment angle (θ) according to the above equations (Maple Software). The transmitter coil is sized at 350 mm * 210 mm and contains 7 turns, while the receiver coil has the same amount of turns but sized at 510 mm * 210 mm. The distance between those two coils is 200 mm (generally, the transmission distance in traditional wireless EVs charging is less than 300 mm, so here it is assumed 200 mm). The calculation results show that the mutual inductance reaches its maximum point ($8 \mu_H$) when two coils in parallel position (θ is $\pi/2$). The mutual inductance is decreasing when two coils' angular misalignment increases.

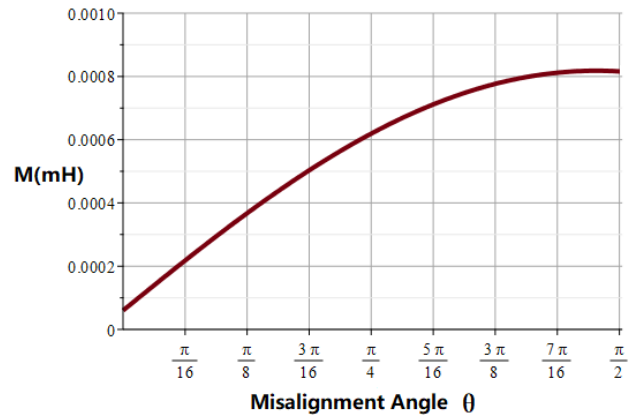

FIGURE 3. The mutual inductance calculation result.

IV. NOVEL COIL DESIGN IN WIRELESS V2V SYSTEM

To solve the angular offset problem in wireless V2V charging, a novel transmitter coil design is now proposed, as shown in Fig. 4. Considering the shape of the front bumper of an EV, a three-sided transmitter coil located at the front of the car is

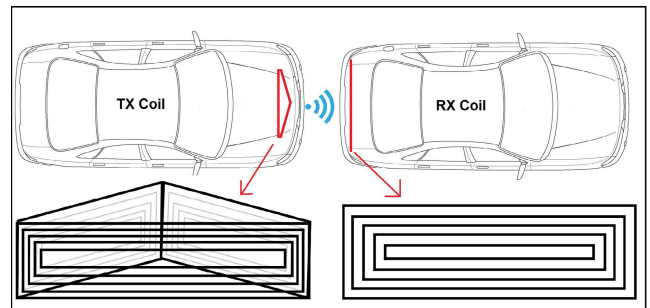

FIGURE 4. Novel coil structure of wireless V2V charging system.

proposed. The receiver coil is a rectangular coil located at the rear of the car, and is of a larger size than the transmitter. To make the coil size design more reasonable, we use the Nissan Leaf in the laboratory as an example model. Coil size design based on Nissan Leaf size and specifications [35]. The transmitting coil can be placed in the space behind the license number plate.

Unlike ordinary wireless EV charging, wireless V2V charging not only suffers from lateral misalignment, but can also have an angular offset. This novel three-sided transmitter coil is able to minimise the reduction in mutual inductance caused by this angular offset, thereby improving the PTE of the system.

As the transmitter and receiver coils are both symmetrical, analysis remains the same for either direction of angular offset. Here, we assume that the receiver coil is angled in a counter-clockwise direction. Fig. 5a shows the structure of the novel transmitter coil design. The top-profile of the transmitter coil forms an isosceles triangle shape, and is a three-sided, 7-turn coil with a base angle of 20° . The receiver coil is a rectangular 7-turn coil of dimensions 510 mm \times 210 mm. When the receiver coil is located on the left of the transmitting EV the left transmitter coil will be connected to the underside coil, otherwise, the right coil will be connected to the underside coil. If there is no angular offset, it is processed according to the first case (left). There is no case where two additional top coils are opened at the same time here. For comparison Fig. 5b shows a benchmark coil which is the flattened version of the novel coil, a three-coil with a parallel arrangement. The size of the benchmark transmitter coil is the same as the proposed novel transmitter coil. The gap between the transmitter coil and the receiver coil chosen as 200 mm. Fig. 5c shows a second benchmark coil with a 11-turn single coil structure designed as to maintain equivalent total inductance compared to the novel and first benchmark coil. This second benchmark coil has the same size as the bottom coil of the three-sided transmitter coil.

A. SOFTWARE SIMULATION

Fig. 6 shows simulated magnetic field strength H results from CST Studio. CST Studio is a 3D EM simulation software providing efficient computational solutions for electromagnetic design and analysis. The transmitter is added 10 A current, and the load at receiver size is 10 Ω . Magnetic flux density is given by $B = \mu_0 H$. Fig. 6 shows simulated H -field results when the receiver and transmitter are positioned at a 15° angular offset, in which colored arrows are used to denote H -field direction and magnitude. These results are taken from a horizontal cross-section of the H -field taken through the center of both coils, with a frequency of 85 kHz. This shows a red area around the receiver coil in the novel transmitter coil structure (Fig. 6c) that is larger than that for the other two structures. In addition, the three-sided transmitter coil structures (Fig. 6c and Fig. 6b) both exhibit stronger H -fields than the single transmitter coil (Fig. 6a).

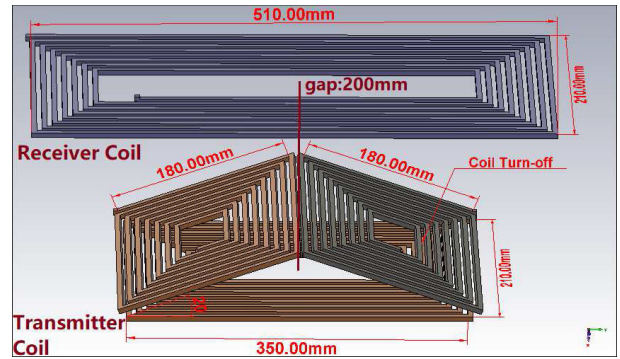

(a) Novel transmitter coil structure

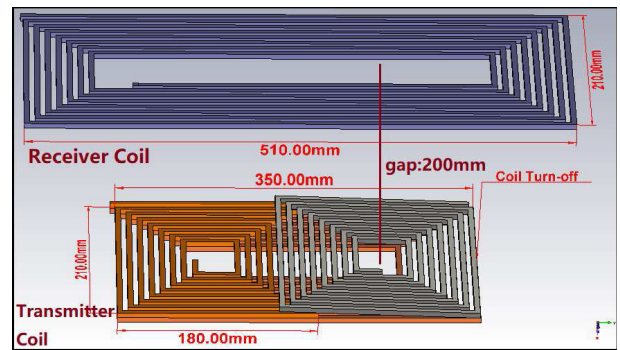

(b) Benchmark transmitter coil structure

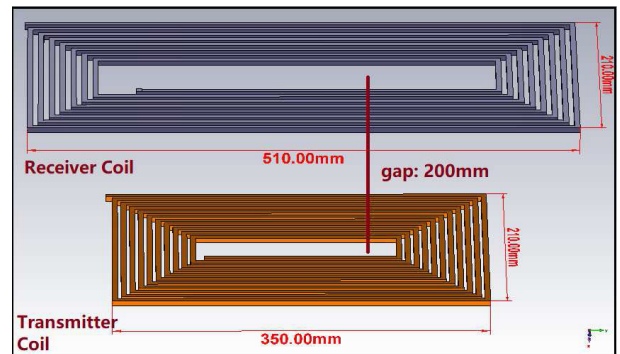

(c) Single transmitter coil structure

FIGURE 5. Structures of the coil design in wireless V2V system.

Fig. 7a shows H -Field values for the above transmitter coil designs over a range of angular offsets from 0° to 25° . In general, the H -field values of the novel transmitter coil structure are higher than the other two transmitter coil structures. The H -field values for the single transmitter coil structure are the worst of these three transmitter structures. In addition, the H -field values of the novel transmitter and the benchmark transmitter increase with larger offset angles, whereas the the H -field value of the single transmitter coil structure decreases for larger angles, due to the receiver's larger size compared to the transmitter.

Considering the safety of the devices, we add the aluminum shielding behind the transmitter coil. The size of the aluminum shielding is 600 mm \times 250 mm, the thickness is 3 mm, the distance between the bottom of the transmitter

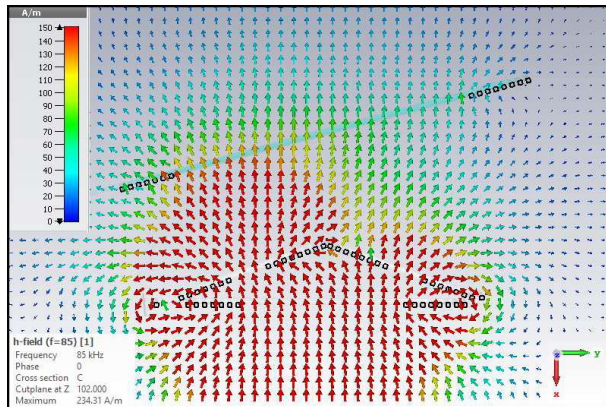

(a) Novel transmitter coil at 15 angular offset

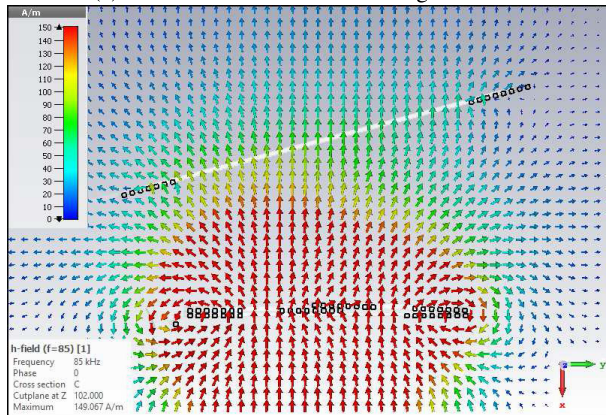

(b) Benchmark transmitter coil at 15 angular offset

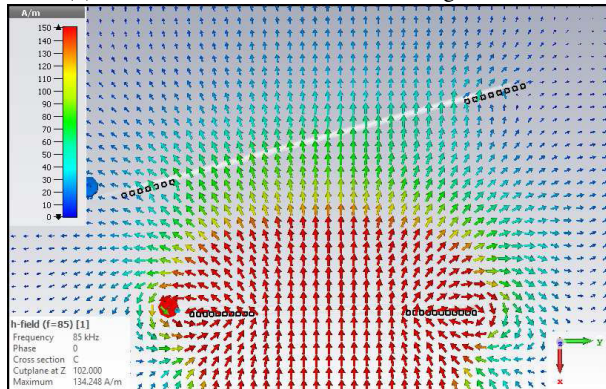

(c) Single transmitter coil at 15 angular offset

FIGURE 6. H-field scalar color mapping results.

coil and aluminum shielding is 40 mm. The simulation result displays the aluminum shielding can effectively reduce the leakage flux, and the H-field value around the coils is less than 20 A/m (blue colour), which equates to 25.1 μ T. According to the ICNIRP 2010 guideline, the magnetic field limit for 3 kHz to 100 kHz is 27 μ T for general-public exposure [36].

B. HARDWARE IMPLEMENTATION

A simulated vehicle-to-vehicle charging testbed has been built to evaluate the proposed coil design simulated in the

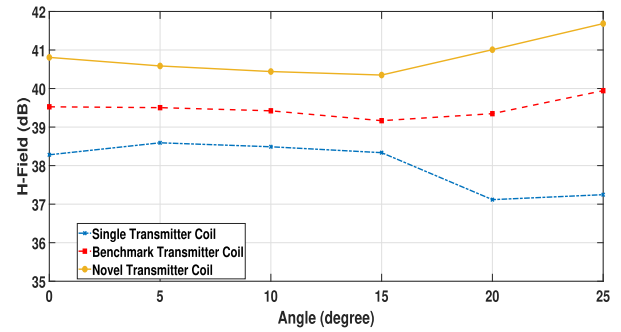

(a) H-field comparison at different angular offset

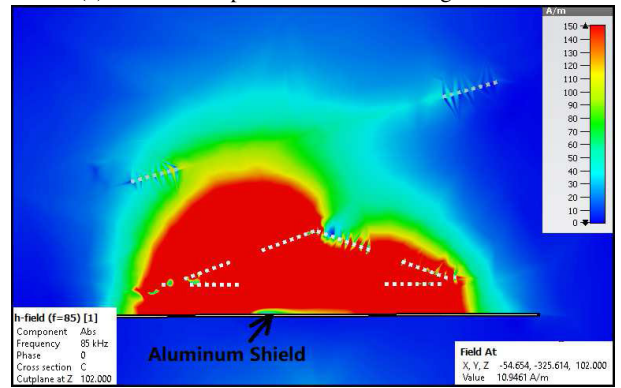

(b) Aluminum Shielding at 15 angular offset

FIGURE 7. Magnetic field comparison and shielding results.

previous section. An overview of the experimental setup is shown in Fig. 8a. The prototype is powered from a 60 V power supplier and a light bulb rated at 60 W is used as the receiver’s load. The proposed resonant system was evaluated with an RMS input voltage of 230 V. Vishay SiHG33N60E were used as power switches together with the converter control system deployed on an STM32F103VGT6 microcontroller. The output of the driving converter is connected to an LC resonant tank, where the transmitting coil serves as the resonant inductor (shown in Fig. 8b). Transmitter coils A, B, and C form the three-sided transmitter coil with parameters given in TABLE 1. A number of film capacitors form the resonant capacitor. On the receiver side, a simple LC resonant receiver consisting of the receiving coil and corresponded capacitor deliver the received energy into a resistive load.

TABLE 1. Parameters of coil and circuit.

Coil	Size mm	Inductance μ H	Capacitance nF
Receiver Coil	510 × 210	226.7	14.6
Transmitter Coil A/(B)	180 × 210	80	11
Transmitter Coil C	350 × 210	171.5	
Single Transmitter Coil	350 × 210	268	10.25
Resonant frequency	85 KHz		
Input Voltage	60 V		
Load	60 W		

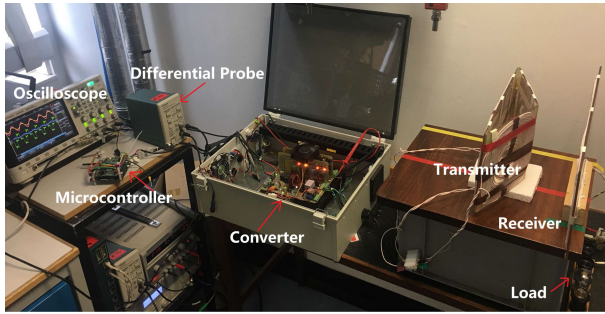

(a) Circuit connection

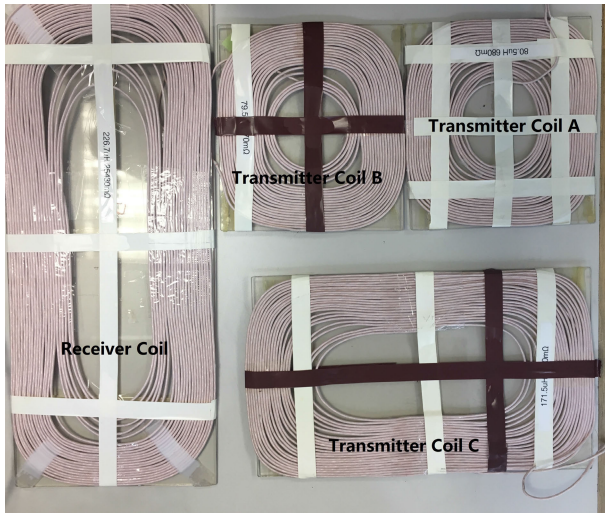

(b) Novel coil structure in hardware implementation

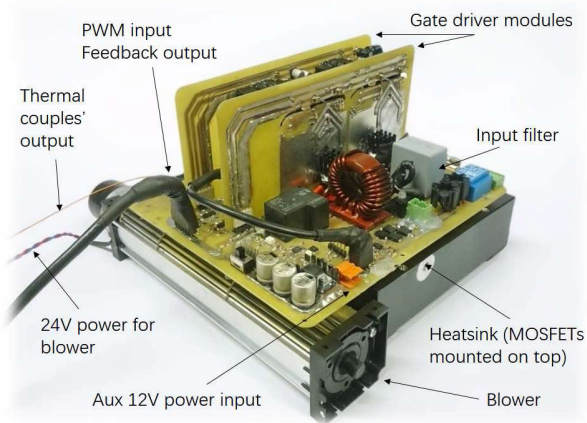

(c) A diagram of the matrix converter [38] [39]

FIGURE 8. Hardware implementation structure.

The transmitting coil is driven from a matrix converter as shown in Fig. 8c. The use of a direct converter allows the elimination of bulky passive energy storage components, reducing on-board weight and physical dimensions. A DC power source was used during this evaluation but a high power AC powered system will be demonstrated in future

publications. In order to evaluate the efficacy of the proposed design, a pre-built test platform was used. This test platform consisting of a universal matrix converter which able to utilising both DC and AC input power and drive the proposed LC tank. However, during the evaluation, DC power source was used with the purpose of stability and accuracy.

The focus of this article is proposing the wireless V2V charging technology, and we used a relatively simple experiment to verify the provided transmitter coil can solve the angular misalignment to improve the power transfer efficiency. However, there are more further engineering technology can be considered in future work as follows:

- 1) Use distance sensor to measure the distances between the receiver coil and the two edges of (left/right) transmitter coil, respectively, to confirm the position of receiver coil and switch the transmitter coil (left/right).
- 2) In addition to using the shielding behind the transmitter coil, we can use two shielding plates as a “door” in front of the car. It will be opened and stay at the left and right sides of the transmitter coil when the car is charging. This design not only plays a role of safety protection but also prevents the car’s front body from being exposed to the magnetic field of the charging coils.
- 3) In principle driver and passenger, need to left their car and keep a certain safe distance from the charging car, no matter whether it is wired or wireless charging. But there has a special case like animals stay between the charger and the car. In order to solve this problem, we can put power failure protection. When the car detected life (infrared sensor) between the car and charger, the charging will stop.

Fig. 9 shows the experimental results and the actual operating frequency is set to 83.75KHz due to tolerance in components. Fig. 9a is the experimental waveforms of resonant circuit when the transmitter coil and the receiver coil have no angular offset. *OUT_V* and *OUT_I* represent transmitter side voltage and current respectively, and *REC_V* and *REC_I* represent receiver side voltage and current respectively. As can be seen from the figure, the PTE of the resonant circuit is around 83%. The detailed system-level PTE of the three coils is shown in Fig. 9b. This measurement of PTE calculated from the power input to the converter and the power output of the receiver coil, which includes converter losses. The system PTE is about 78% when no angular offset happens in novel transmitter case. That means the converter loss is around 5%.

As can be seen from Fig. 9b, the PTE of the single transmitter coil is the worst of these three structures, but this does not significantly vary with angular offset. This is due to the larger size of receiver coil compared to the transmitter, and so the effective area among two coils remains the same. Up to 90% efficiency is demonstrated by the novel transmitter coil structure, while the benchmark transmitter coil structure reaches 80%. The efficiency of the novel transmitter coil increases significantly than the benchmark coil and larger increases in efficiency for larger angular offsets. Moreover,

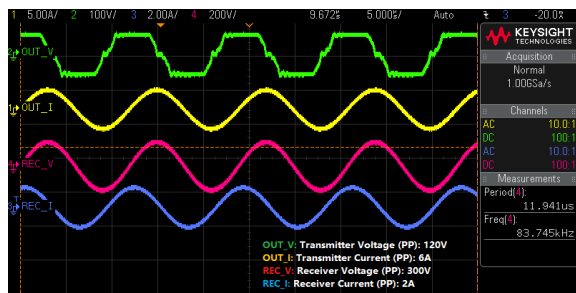

(a) Experimental waveforms of resonant circuit when angular offset is 0 in novel transmitter coil case

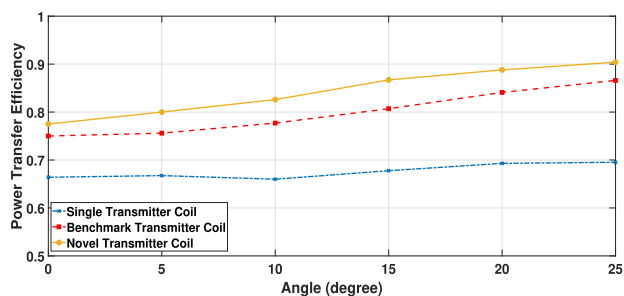

(b) Experimental system PTE (includes converter efficiency) over angular offset for the three considered transmitter coil structures

FIGURE 9. Hardware implementation results.

the novel transmitter coil efficiency seems to increase fastest when the angular offset less than 15° . From these results, it is clear that the novel transmitter coil yields improved efficiency when the resonant coils have an angular offset.

V. CONCLUSION

This paper has presented a V2V charging system that can work together with plug-in charging EVs, or operate independently. It can effectively address issues due to both the limited number of plug-in stations and the risk of an EV running out of power during a trip. Wireless power transfer technology has become a priority for V2V charging due to its convenience. A traditional wireless EV charging topology places the transmitter coil in the ground, and the receiver within the undercarriage of the vehicle. In a wireless V2V charging system the resonant coils are instead located at the front and rear of the vehicle, meaning an angular offset is often present. A triangular shaped transmitter coil structure is proposed in this paper that is able to effectively address this angular misalignment problem. This is compared with a benchmark three-coil (parallel) transmitter structure. The simulation results show that the H -field of the novel transmitter coil is higher than the benchmark transmitter coil structure when the resonant coils have an angular offset. Experimental results for a hardware implementation show that the novel transmitter coil improves the efficiency of the system compared to the benchmark structure. The proposed converter is designed to deliver up to 2 kW over-the-air power.

Hence, power losses became significant at low power conditions. This paper mainly focused on proposing the wireless V2V charging technology, and the analysis of the triangular transmitter coil design which can solve the angular offset in the system. There also have some areas for improvement in the future, e.g. the angular misalignment analysis under variable gaps, the variation of efficiency with different loads and power level analysis, the copper losses and other losses analysis. Moreover, a high power system that is suited to the practical wireless EV charging will be set up in the future.

REFERENCES

- [1] J. Traube, F. Lu, D. Maksimovic, J. Mossoba, M. Kromer, P. Faill, S. Katz, B. Borowy, S. Nichols, and L. Casey, "Mitigation of solar irradiance intermittency in photovoltaic power systems with integrated electric-vehicle charging functionality," *IEEE Trans. Power Electron.*, vol. 28, no. 6, pp. 3058–3067, Jun. 2013.
- [2] S. Li and C. C. Mi, "Wireless power transfer for electric vehicle applications," *IEEE J. Emerg. Sel. Topics Power Electron.*, vol. 3, no. 1, pp. 4–17, Mar. 2015.
- [3] A. Ahmad, M. S. Alam, and R. Chabaan, "A comprehensive review of wireless charging technologies for electric vehicles," *IEEE Trans. Transport. Electric.*, vol. 4, no. 1, pp. 38–63, Mar. 2018.
- [4] P. K. Joseph, E. Devaraj, and A. Gopal, "Overview of wireless charging and vehicle-to-grid integration of electric vehicles using renewable energy for sustainable transportation," *IET Power Electron.*, vol. 12, no. 4, pp. 627–638, Apr. 2019.
- [5] H. Fu, Z. S. Khodaei, and M. H. F. Aliabadi, "An event-triggered energy-efficient wireless structural health monitoring system for impact detection in composite airframes," *IEEE Internet Things J.*, vol. 6, no. 1, pp. 1183–1192, Feb. 2019.
- [6] *When Can We Expect Wireless Charging for Electric Vehicles?* Accessed: Aug. 2, 2017. [Online]. Available: <https://www.fleetcarma.com>
- [7] Society of Automotive Engineers. *SAE Standard j2954: Wireless Power Transfer for Light-Duty Plug-in/Electric Vehicles and Alignment Methodology*. Accessed: May 26, 2016. [Online]. Available: <https://www.sae.org/standards/content/j2954-201904/>
- [8] P. Minto. *Recent Policies From the UK Government Show Commitment to EVs*. Accessed: Aug. 6, 2018. [Online]. Available: <https://www.intelligenttransport.com/transport-articles/70303/uk-government-electric-vehicles/>
- [9] A.-M. Koufakis, E. S. Rigas, N. Bassiliades, and S. D. Ramchurn, "Offline and online electric vehicle charging scheduling with V2 V energy transfer," *IEEE Trans. Intell. Transport. Syst.*, vol. 21, no. 5, pp. 2128–2138, May 2020.
- [10] E. Bulut, M. C. Kisacikoglu, and K. Akkaya, "Spatio-temporal non-intrusive direct V2 V charge sharing coordination," *IEEE Trans. Veh. Technol.*, vol. 68, no. 10, pp. 9385–9398, Oct. 2019.
- [11] C. Liu, K. T. Chau, D. Wu, and S. Gao, "Opportunities and challenges of vehicle-to-home, vehicle-to-vehicle, and vehicle-to-grid technologies," *Proc. IEEE*, vol. 101, no. 11, pp. 2409–2427, Nov. 2013.
- [12] R. Zhang, X. Cheng, and L. Yang, "Flexible energy management protocol for cooperative EV-to-EV charging," *IEEE Trans. Intell. Transport. Syst.*, vol. 20, no. 1, pp. 172–184, Jan. 2019.
- [13] G. Li, Q. Sun, L. Boukhatem, J. Wu, and J. Yang, "Intelligent vehicle-to-vehicle charging navigation for mobile electric vehicles via VANET-based communication," *IEEE Access*, vol. 7, pp. 170888–170906, 2019.
- [14] M. Abdolmaleki, N. Masoud, and Y. Yin, "Vehicle-to-vehicle wireless power transfer: Paving the way toward an electrified transportation system," *Transp. Res. Part C, Emerg. Technol.*, vol. 103, pp. 261–280, Jun. 2019.
- [15] M. A. Masrur, A. G. Skowronska, J. Hancock, S. W. Kolhoff, D. Z. McGrew, J. C. Vandiver, and J. Gatherer, "Military-based vehicle-to-grid and vehicle-to-vehicle microgrid—System architecture and implementation," *IEEE Trans. Transport. Electric.*, vol. 4, no. 1, pp. 157–171, Mar. 2018.
- [16] T. J. C. Sousa, V. Monteiro, J. C. A. Fernandes, C. Couto, A. A. N. Melendez, and J. L. Afonso, "New perspectives for vehicle-to-vehicle (V2 V) power transfer," in *Proc. IECON-44th Annu. Conf. IEEE Ind. Electron. Soc.*, Oct. 2018, pp. 5183–5188.

- [17] X. Mou, R. Zhao, and D. T. Gladwin, "Vehicle to vehicle charging (V2V) bases on wireless power transfer technology," in *Proc. IECON-44th Annu. Conf. IEEE Ind. Electron. Soc.*, Oct. 2018, pp. 4862–4867.
- [18] X. Mou, R. Zhao, Y. Wang, and D. Gladwin, "Angular offset analysis in wireless vehicle to vehicle (V2V) charging system," in *Proc. IECON-45th Annu. Conf. IEEE Ind. Electron. Soc.*, vol. 1, Oct. 2019, pp. 4293–4297.
- [19] X. Mou, D. T. Gladwin, R. Zhao, and H. Sun, "Survey on magnetic resonant coupling wireless power transfer technology for electric vehicle charging," *IET Power Electron.*, vol. 12, no. 12, pp. 3005–3020, Oct. 2019.
- [20] D. Patil, M. K. McDonough, J. M. Miller, B. Fahimi, and P. T. Balsara, "Wireless power transfer for vehicular applications: Overview and challenges," *IEEE Trans. Transport. Electrific.*, vol. 4, no. 1, pp. 3–37, Mar. 2018.
- [21] X. Mou, O. Groling, and H. Sun, "Energy-efficient and adaptive design for wireless power transfer in electric vehicles," *IEEE Trans. Ind. Electron.*, vol. 64, no. 9, pp. 7250–7260, Sep. 2017.
- [22] L. Zhao, D. J. Thrimawithana, and U. K. Madawala, "Hybrid bidirectional wireless EV charging system tolerant to pad misalignment," *IEEE Trans. Ind. Electron.*, vol. 64, no. 9, pp. 7079–7086, Sep. 2017.
- [23] J. Wang, S. L. Ho, W. N. Fu, and M. Sun, "Analytical design study of a novel witrlicity charger with lateral and angular misalignments for efficient wireless energy transmission," *IEEE Trans. Magn.*, vol. 47, no. 10, pp. 2616–2619, Oct. 2011.
- [24] F. Liu, Y. Yang, D. Jiang, X. Ruan, and X. Chen, "Modeling and optimization of magnetically coupled resonant wireless power transfer system with varying spatial scales," *IEEE Trans. Power Electron.*, vol. 32, no. 4, pp. 3240–3250, Apr. 2017.
- [25] Y. M. Roshan and E. J. Park, "Design approach for a wireless power transfer system for wristband wearable devices," *IET Power Electron.*, vol. 10, no. 8, pp. 931–937, Jun. 2017.
- [26] J. P. W. Chow, N. Chen, H. S. H. Chung, and L. L. H. Chan, "An investigation into the use of orthogonal winding in loosely coupled link for improving power transfer efficiency under coil misalignment," *IEEE Trans. Power Electron.*, vol. 30, no. 10, pp. 5632–5649, Oct. 2015.
- [27] M. Kavitha, P. B. Bobba, and D. Prasad, "Effect of coil geometry and shielding on wireless power transfer system," in *Proc. IEEE 7th Power India Int. Conf. (PIICON)*, Nov. 2016, pp. 1–6.
- [28] W. Zhang, J. C. White, A. M. Abraham, and C. C. Mi, "Loosely coupled transformer structure and interoperability study for EV wireless charging systems," *IEEE Trans. Power Electron.*, vol. 30, no. 11, pp. 6356–6367, Nov. 2015.
- [29] Y. Liu, Y. Zhu, and Y. Cui, "Challenges and opportunities towards fast-charging battery materials," *Nature Energy*, vol. 4, no. 7, pp. 540–550, Jul. 2019.
- [30] H. Lee and A. Clark, "Charging the future: Challenges and opportunities for electric vehicle adoption," Harvard Kennedy School, Cambridge, MA, USA, Tech. Rep. HKS Work. Paper No. RWP18-026, 2018.
- [31] H. Greenhouse, "Design of planar rectangular microelectronic inductors," *IEEE Trans. Parts, Hybrids, Packag.*, vol. TPHP-10, no. 2, pp. 101–109, Jun. 1974.
- [32] F. Grover, *Inductance Calculations: Working Formulas and Tables* (Dover Books on Engineering and Engineering Physics). Research Triangle Park, NC, USA: ISA, 1982. [Online]. Available: <https://books.google.co.uk/books?id=rqceAQAAlAAJ>
- [33] Y. Lee. *Antenna Circuit Design For RFID Applications*. Accessed: May 28, 2010. [Online]. Available: <http://ww1.microchip.com/downloads/en/AppNotes/00710c.pdf>
- [34] Y. Cheng and Y. Shu, "A new analytical calculation of the mutual inductance of the coaxial spiral rectangular coils," *IEEE Trans. Magn.*, vol. 50, no. 4, pp. 1–6, Apr. 2014.
- [35] *Antenna Circuit Design For RFID Applications*. Accessed: May 28, 2010. [Online]. Available: <https://www.nissan.co.uk/vehicles/new-vehicles/leaf/dimensions-specifications.html>
- [36] M. Mohammad, J. Pries, O. Onar, V. P. Galigekere, G.-J. Su, S. Anwar, J. Wilkins, U. D. Kavimandan, and D. Patil, "Design of an EMF suppressing magnetic shield for a 100-kW DD-coil wireless charging system for electric vehicles," in *Proc. IEEE Appl. Power Electron. Conf. Expo. (APEC)*, Mar. 2019, pp. 1521–1527.
- [37] R. Zhao, D. T. Gladwin, and D. A. Stone, "Cost efficient matrix converter employing a conventional simple controller," in *Proc. PCIM Asia; Int. Exhib. Conf. Power Electron., Intell. Motion, Renew. Energy Energy Manage.*, Jun. 2015, pp. 1–8.
- [38] R. Zhao, D. T. Gladwin, and D. A. Stone, "Wireless power system applying a microcontroller dominated matrix converter," in *Proc. IECON-41st Annu. Conf. IEEE Ind. Electron. Soc.*, Nov. 2015, pp. 3405–3410.

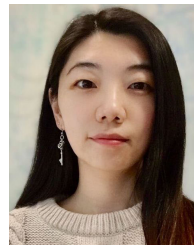

XIAOLIN MOU (Member, IEEE) received the B.Eng. degree (Hons.) in electronics engineering from Anglia Ruskin University, U.K., in 2012, the M.Sc. degree in satellite communication from the University of Sussex, U.K., in 2013, and the Ph.D. degree in electronics engineering from Durham University, U.K., in 2017.

She is currently working as a Postdoctoral Research Associate with the EMD Group, The University of Sheffield, U.K. Her research interests include wireless power transfer (WPT) technology for electric vehicle (EV) charging, particularly in magnetic resonant coupling WPT, dynamic wireless EV charging through renewable energy, vehicle to vehicle (V2V) wireless charging, energy storage, and wireless UAVs charging.



DANIEL T. GLADWIN (Senior Member, IEEE) received the M.Eng. degree (Hons.) in electronic engineering (computer architecture) and the Ph.D. degree in automated control structure design and optimization using evolutionary computing from The University of Sheffield, Sheffield, U.K., in 2004 and 2009, respectively. He was a Lecturer with The University of Sheffield, in 2012, a Senior Lecturer, in 2017, and a Professor, in 2020. He is currently a Founding Member and the Deputy Director of the Centre for Research into Electrical Energy Storage and Applications (CREESA), The University of Sheffield. His current research interests include energy storage and management, power electronics, optimization, and intelligent systems.

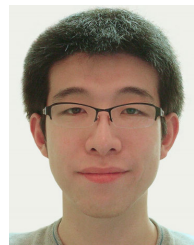

RUI ZHAO received the Ph.D. degree from the Electrical Machines and Drives Research Group, The University of Sheffield, where he developed novel converter topologies and controls for both conventional and contactless power systems suitable for applications in electric vehicles (EVs) and unmanned aerial vehicles (UAVs). From 2009 to 2012, he founded Cydra System, developing management units and power inverters for solar power applications. He is currently a Research Associate with the CREESA Group, The University of Sheffield, where he is working on high-energy power conversion and storage systems. His research interests include power electronics, energy conversion, and storage.



HONGJIAN SUN (Senior Member, IEEE) received the Ph.D. degree in electronic and electrical engineering from The University of Edinburgh, U.K., in 2011.

He held a postdoctoral position with King's College London, U.K., and Princeton University, USA. Since 2013, he has been a Reader in Smart Grid with the University of Durham, U.K. From 2013 to 2017, he was a Lecturer with the University of Durham. He has made contributions to and coauthored the IEEE 1900.6a-2014 Standard. He has authored or coauthored over 100 papers in refereed journals and international conferences, five book chapters, and edited two books: *IET book Smarter Energy: From Smart Metering to the Smart Grid*, and *CRC Book From Internet of Things to Smart Cities: Enabling Technologies*. His research interests include smart grid: communications and networking, smart grid: demand side management and demand response, and smart grid: renewable energy sources integration. He is the Editor-in-Chief of *IET Smart Grid journal* and an Editor of the *Journal of Communications and Network*. He also served as a Guest Editor for *IEEE Communication Magazine* for several feature topics, including Integrated Communications, Control, and Computing Technologies for Enabling Autonomous Smart Grid, 2016.



ZHILE YANG (Member, IEEE) received the B.Sc. degree in electrical engineering and the M.Sc. degree in control engineering from Shanghai University (SHU), in 2010 and 2013, respectively, and the Ph.D. degree from the School of Electrical, Electronics and Computer Science, Queen's University Belfast (QUB), U.K.

He worked as a Research Assistant with QUB. He was a Research Fellow with Cardiff University. He is currently an Associate Professor with the

Shenzhen Institutes of Advanced Technology, Chinese Academy of Sciences, Shenzhen, China. He is the author or coauthor of more than 100 papers in peer-reviewed international journals and conferences. His research interests include artificial intelligence methods and their applications on smart grid and advanced manufacturing. He is the Founding Chair of the IEEE QUB Student Branch and an Active Member of the IEEE PES, CIS, and SMC societies. He is an Active Reviewer for over 50 international journals.

• • •