



This is a repository copy of *Manufacturing data for the implementation of data-driven remanufacturing for the rechargeable energy storage system in electric vehicles*.

White Rose Research Online URL for this paper:  
<http://eprints.whiterose.ac.uk/142307/>

Version: Accepted Version

---

**Proceedings Paper:**

Okorie, O., Salonitis, K., Charnley, F. et al. (3 more authors) (2019) Manufacturing data for the implementation of data-driven remanufacturing for the rechargeable energy storage system in electric vehicles. In: Dao, D., Howlett, R., Setchi, R. and Vlacic, L., (eds.) Sustainable Design and Manufacturing 2018. 5th International Conference on Sustainable Design and Manufacturing (KES-SDM-18), 24-26 Jun 2018, Gold Coast, Australia. Smart Innovation, Systems and Technologies, 130 . Springer , pp. 277-289. ISBN 9783030042899

[https://doi.org/10.1007/978-3-030-04290-5\\_28](https://doi.org/10.1007/978-3-030-04290-5_28)

---

This is a post-peer-review, pre-copyedit version of a paper published in Dao et al (eds.), Sustainable Design and Manufacturing 2018, Springer, 2019. The final authenticated version is available online at: [https://doi.org/10.1007/978-3-030-04290-5\\_28](https://doi.org/10.1007/978-3-030-04290-5_28)

**Reuse**

Items deposited in White Rose Research Online are protected by copyright, with all rights reserved unless indicated otherwise. They may be downloaded and/or printed for private study, or other acts as permitted by national copyright laws. The publisher or other rights holders may allow further reproduction and re-use of the full text version. This is indicated by the licence information on the White Rose Research Online record for the item.

**Takedown**

If you consider content in White Rose Research Online to be in breach of UK law, please notify us by emailing [eprints@whiterose.ac.uk](mailto:eprints@whiterose.ac.uk) including the URL of the record and the reason for the withdrawal request.



[eprints@whiterose.ac.uk](mailto:eprints@whiterose.ac.uk)  
<https://eprints.whiterose.ac.uk/>

# Manufacturing Data for the Implementation of Data-Driven Remanufacturing for the Rechargeable Energy Storage System in Electric Vehicles.

\*Okechukwu Okorie<sup>1</sup>, K. Salonitis<sup>1</sup>, F. Charnley<sup>2</sup>, M. Moreno<sup>2</sup>, C. Turner<sup>3</sup> and A. Tiwari<sup>4</sup>

<sup>1</sup>Cranfield University, School of Aerospace, Transport and Manufacturing, Bedfordshire, United Kingdom

<sup>2</sup>Cranfield University, Centre for Competitive Design, School of Water, Energy and Environment, Bedfordshire, United Kingdom

<sup>3</sup>University of Surrey, Surrey Business School, Surrey, United Kingdom.

<sup>4</sup>University of Sheffield, Department of Automatic Control & Systems Engineering, Sheffield, United Kingdom.

Corresponding author: o.s.okorie@cranfield.ac.uk

**Abstract.** Manufacturing industries are experiencing a data-driven paradigm shift that is changing how technical operations are run and changing present business models. Leveraging on manufacturing data from industries and digital intelligence platforms have become important in creating new forms of value. While extending the life of a product through the circular economy 3 R's of reuse, remanufacturing and recycling remains a technical and resource challenge for practitioners, optimizing the increasing forms and volumes of data presents a complementary and necessary challenge to the circular economy. This research aims to explore how the manufacturing data can inform remanufacturing parameters for implementing remanufacturing on the Rechargeable Energy Storage System.

**Keywords:** Remanufacture, Rechargeable Energy Storage System, Circular Approach, Decision-Making, Internet of Things

## 1 Introduction

Research has shown that interest in End of Life (EoL) approaches within the academia and industry has experienced an increase, [1], with the focus on reuse, recycling and remanufacturing of materials. This increase is largely driven by legislative and environmental pressures from governments and policymakers, [2] external factors such as climate change, [3] and internally by businesses, as they seek new ways of increasing efficiency of materials and reducing waste.. Remanufacturing is defined as the process where used, damaged or discarded products are returned to a standard which is the same as or better than the original product, [3].

As one of the key strategies of the circular economy, research in remanufacturing has had a varied interest amongst academics. These include remanufacturing research

that concerns inventory and inventory control policies, [4], [5] and remanufacturing for reverse supply chains, [5][6], decision-support tools and decision-making in remanufacturing, [7], [8], [9] and design for remanufacture [10], [11],[2]. In addition, findings has shown that amongst the circular strategies of reuse, remanufacture and recycling, research on remanufacturing and digital technologies, ranks the lowest [1]. The advent of Industry 4.0 and with it, digital technologies and the Internet of Things presents new opportunities and challenges for circular economy and remanufacturing. As a recent PWC study indicated, [12], by 2020, more than 80% of companies in Europe would have digitalized their value chain with a projected 18% in higher productivity. Thus, data volume and digitization form a core part of Industry 4.0, as a mechanism and an enabler, [12]. However, digitization of remanufacturing processes is not as easily achievable and is still a growing area of research, as findings have shown, [1].

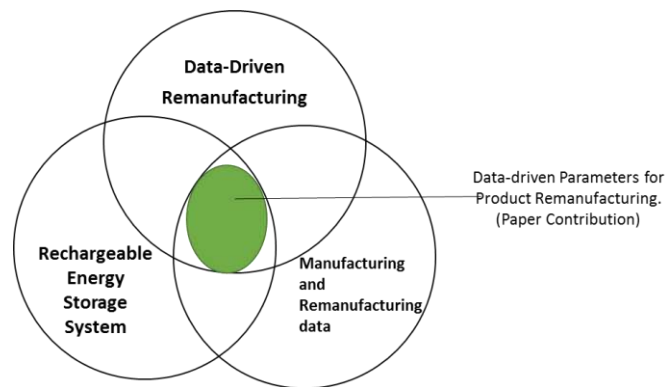

**Fig 1: Research Focus for Paper.**

Figure 1 shows the contribution of knowledge for this paper. The aim of this paper is to;

1. Explore the requirements of data for enabling the digitization of remanufacturing for the Rechargeable Energy Storage System
2. Identify the parameters required for enabling digitisation of remanufacturing
3. Develop a relationship between remanufacturing parameters and the rate and quality of remanufacturing.

. Also at the end of its useful life, the core must have sufficiently high value of labor, energy and capital embodied in it, enough to be recoverable. Findings in [14] show that 70% of all remanufacturing companies belong to the automotive sector. As remanufacturing of automotive products is an effective strategy for promoting sustainability in the automotive industry, it becomes essential to undertake research into hybrid and electric automobiles which are on an annual increase, globally [15]

## 2 State of the Art

### 2.1 Rechargeable Energy Storage System

The search for cleaner energy sources for transportation has led to a focus on Internal Combustion Engines (ICE) as this part of the automobile are the major contributors to toxic emissions to the atmosphere. A combustion chamber is used to convert chemical energy of fossil fuel into kinetic energy to run the vehicle, thus producing toxic gases [22]. These emissions contribute to climate change and air pollution, hence affecting the health of people, [23]. Hybrid Electric Vehicles (HEV) and Electric Vehicles (EV) thus were developed to introduce a sustainable solution to the challenges posed by the ICE. HEVs incorporate the ICE and electric motor, EM, as energy source while the EVs utilizes only electrical power for vehicle propulsion, [22]. Figure 3 below, adapted from [22] gives a schematic diagram of the power train of a Fuel Cell Hybrid Electric Vehicle which includes the Rechargeable Energy Storage System.

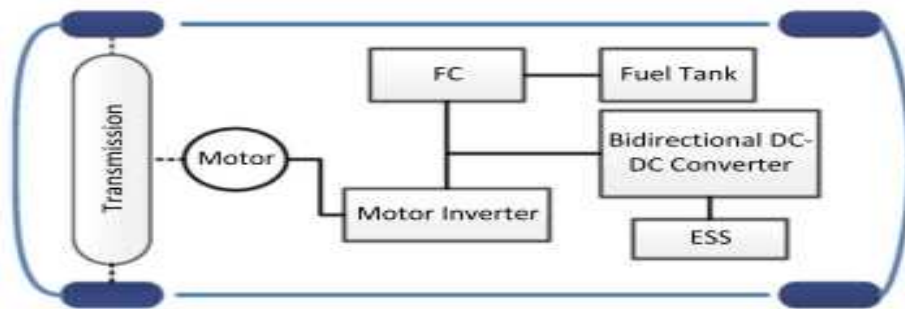

**Fig. 3.** Powertrain configuration of a FCHEV [26]

Rechargeable Energy Storage Systems (RESS) and Hybrid Energy Storage Systems (HESS) consists of fuel cells, supercapacitors and a battery component in one system, [24]. The entire EV/HEV is a sensor embedded product, SEP [25], containing implanted sensors at various points which monitors critical components while they are in use. The sensors in the automobile and around the RESS form part of the Battery Management System or BMS; this collects “degradability” data which can help predict component failures and provide information on their remaining useful life, [26]. Despite the benefits of these RESS – lightweight, high rate capability for fast charging/ discharging, –questions surrounding their end of life state are still unanswered by researchers, especially within the context of the Internet of Things and remanufacturing. Design for Remanufacture (DfRem) concept, for instance, informs that [27] parameters such as data, are important in improving the remanufacturing efficiency of a product. As the EV and the RESS utilizes a vast amount of data, sensors and related hardware, this poses an interesting challenge for remanufacturing.

## 2.2 Remanufacturing and the Internet of Things

IoT presents an interesting opportunity for remanufacturing and sustainability. IoT and smart manufacturing is the basic principle of Industry 4.0, where work in progress products, components and production machines will collect and share data in real time, [29]. SCOPUS search using the keywords, “Remanufacture\*” and “internet of thing\*” reveals only 12 results with the most papers being published in 2017. This is shown in Figure 4.

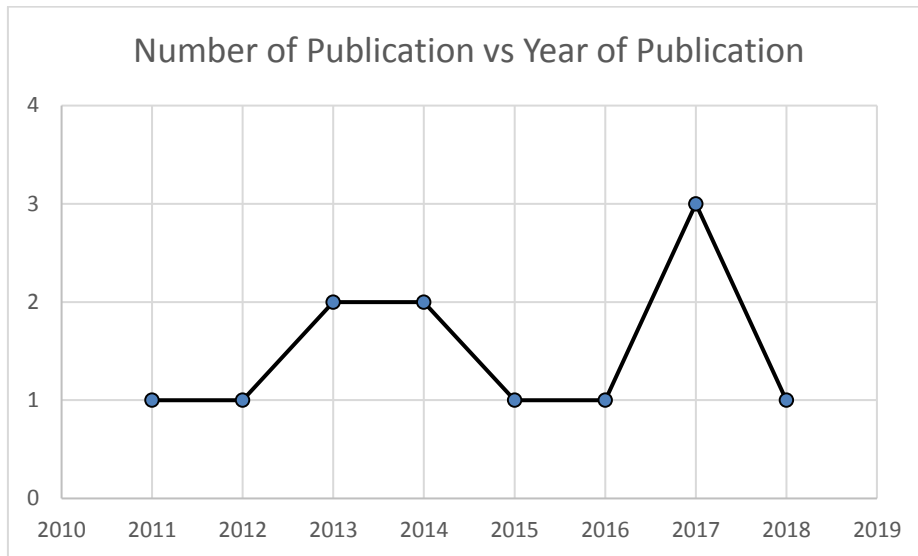

Fig. 4. Number of Research vs Year of Research on SCOPUS.

There are several potential benefits which the interaction with Remanufacturing and the Internet of Things may still well bring. Ondemir & Gupta in [25] argues that IoT with remanufacturing has the potential to mitigate the planning of remanufacturing operations by reducing or almost eliminating uncertainty through the use of Radio-Frequency Identification (RFID) tags. Active RFID tags with embedded sensors can provide useful information about the usage/ condition of every single object in a machine, [25]. Other smart sensors for product EoL recovery include, Electronic Data Log (EDL), [30], Autonomous Monitoring Device [31] and Life-cycle unit (LCU) [32]. IoT-enabled devices have the potential to affect the viability and profitability of remanufacturing, [28] by increasing or reducing the viability and profitability of the conditions of returned products.

## 2.3 Parameters for Remanufacturing

In order to understand which manufacturing data is needed to enable data-driven remanufacturing, it is important to understand the parameters required for product remanufacturing. Parameters required for end-of-life approaches are normally obtained from

an examination of the type of product and the function of the product during its useful life. Hatcher et al, [38] describes it as “characteristics for manufacturability”, [33] Condition-based maintenance, which recommends maintenance decisions based on information obtained through monitoring of the machine-product for instance [34], focuses on the behavior of the product during in-service. Thus the parameters for condition-based maintenance include variables such as temperature, vibration analysis data, oil analysis data, weather or environment data, etc, data which are acquired through sensors [34]. Parameters for product recycling are developed from an understanding of the material composition and their potential use, [35]. Not every product can be remanufactured. As stated earlier, a product being remanufactured must go through the broad processes of disassembly, inspection, cleaning, reprocessing, testing and reassembly. Thus the parameter for remanufacturing must first broadly begin with an assessment if the product is capable of “disassembly”. [41] proposes a robust method, “eDIM”, to calculate the disassembly time for remanufacturable products [36]. Availability of technology to restore the product, availability of standard interchangeable parts, cost of core being low relative to savings in product cost achieved through core reuse, concludes the parameters for remanufacture, [37].

It is expected that, like condition-based end of life maintenance, the use sensors within products which in turn will produce more data, will have an impact on the parameters for remanufacturing, increasing the number of parameters as remanufacturing becomes more data-driven. The sensors, for instance, will be able to detect more parameters and this will form part of new research into design for data-driven remanufacture.

### **3 Research design**

#### **3.1 Interviews**

Semi-structured interviews were utilized for this research. It is a type of data collection method which pursues its line of inquiry with a set of predetermined questions that administered based on the interviewer’s perception of what seems most appropriate, [38]. This was chosen over “focus group” which, as argued by Nigel King [44], fits this type of exploratory work, as it was difficult to bring the different respondents to one single table or platform, as required in focus groups[39]. Compared to fully structured or unstructured interviews, this system of data collection offers greater flexibility as it encourages a discussion between the interviewer and the respondent and hence can give important insights which may not have been captured by the pre-written questions.

For this research the developed questions were investigations into (i) the type of manufacturing data utilized in the manufacturing and remanufacturing process of the respondents (ii) the parameters for remanufacturing and (iii) if these manufacturing data had an impact on enabling or impeding these parameters. For the case study company involved in the manufacture of EVs, manufacturing data discussions were centered on manufacturing the powertrain and RESS component. Respondents selected for interview were all employees of the company at the management level, with different roles

and responsibilities. All respondents had an extensive experience in manufacturing, re-manufacturing, sustainability and the Circular Economy. An interview guide was developed to aid the interviews and this can be found in Appendix A.

### **3.2 Selection of manufacturing data to enable remanufacturing parameters for the RESS.**

Current discussions about data has centered on “*Big Data*”. This is data which is characterized by the three V’s of data; volume, velocity and variety of data, according to Gartner [40]. “Traditional forms” such as structured data (spreadsheets, relational databases, enterprise data warehouse, files stored in manufacturing PCs), real-time or semi-structured data (data from sensors, relays, RFID, XML, time series data structures) and unstructured data (operator shift reports, machine logs, error logs, texts, images, audio/video, manufacturing collaboration on social platforms), [41].

Remanufacturing companies selected for this research were selected from the database of remanufacturing companies of “European Remanufacturing Network”, (<http://www.remanufacturing.eu>). This is, as described, a “pan-European project to understand the shape of remanufacturing in the EU”. This database was found to hold remanufacturing-related case studies from a comprehensive list of companies involved in remanufacturing. Case studies include industries such as, aerospace, automotive, electrical and electronic, marine, furniture, etc; a total of 66 company’s case studies within 10 key industry sectors. Also include PSS, a Third Party Remanufacturer of automobile mechanical components, HSSMI, a research institution focusing on data-driven remanufacture of fuel cells. Three others participated and but proceeded on the basis of anonymity. They are described as Company C, Company D and Company E, involved in EVs manufacture, automotive remanufacture for electrical parts and an automotive remanufacturer (OEM), respectively. Information about these companies is presented in (Table 1). Table 2 gives an AS-IS and TO-BE analysis of various parameters and desired improvements per company.

Company	Type	Size	Number of Respondents	Circular Approach	Cus-tomers	Role of Re-spondent	Years of Experi-ence	Means of Interview
PSS	Automotive	55	1	Reman.	Global	Managing Director	33	On-site visit
HSSMI	Research	31	1	Reman, Re-use, Recycle	Global, Europe-focused	Manager of Circular Economy and Digital Manufacturing	6	Interviews/ visits
Company C	Automotive	24	2	(Reman. currently being discussed)	UK market	1. Systems and Sustainability Engineer.  2. Software & Systems Architect	1. 13  2. 27	On-site visit
Company D	Automotive (Electrical)	NA	1	Remanu-facture	UK market	Managing Director	32	Interviews
Company E (Third Party OEM)	Automotive (OEM)	NA	1	Remanu-facture, Recycle	Global.	Head, Re-manufacturing Development	NA	Email

**Table 1:** Information of companies involved in taxonomy of manufacturing data research



<b>Name of Company</b>	<b>Parameters Utilised for Remanufacture</b>	<b>Parameters desired for Remanufacture (Improvements)</b>
PSS	Can be disassembled, Proximity to OEM, Proximity to Suppliers	Can data inform if a product from the OEM can be remanufactured or not? CO <sub>2</sub> emissions data (CO <sub>2</sub> utilised during entire supply chain process of remanufacture)
HSSMI	Can be disassembled, Current, Voltage, Temperature, Vibration Data.	Manufacturing parameters for RESS and Fuel Cells at identified time/period.
Company C	Can be disassembled, Current, Voltage, Temperature, Vibration Data, Inlet Pressure, Distance from OEM to third party remanufacturer.	Manufacturing parameters for RESS and Fuel Cells at identified time/period, CO <sub>2</sub> emissions data (CO <sub>2</sub> utilised during entire supply chain process of remanufacture)
Company D	Can be disassembled, Proximity to OEM, Proximity to Suppliers	Can data inform if a product from the OEM can be remanufactured or not? CO <sub>2</sub> emissions data (CO <sub>2</sub> utilised during entire supply chain process of remanufacture), Temperature data for auto electrical components
Company E (Third Party OEM)	Profit margin from remanufacturing, proximity to third party remanufacturer	CO <sub>2</sub> emissions data (CO <sub>2</sub> utilised during entire supply chain process of remanufacture), Cost per product data.

**Table 2:** AS-IS Remanufacturing Parameters and TO BE Parameters and Improvements Sought per Company

## 4 Results

### 4.1 Manufacturing Data Types

The chart in Figure 5 below demonstrates the use of structured data, semi-structured data and unstructured data by the companies involved in the interview in Section 2 above.

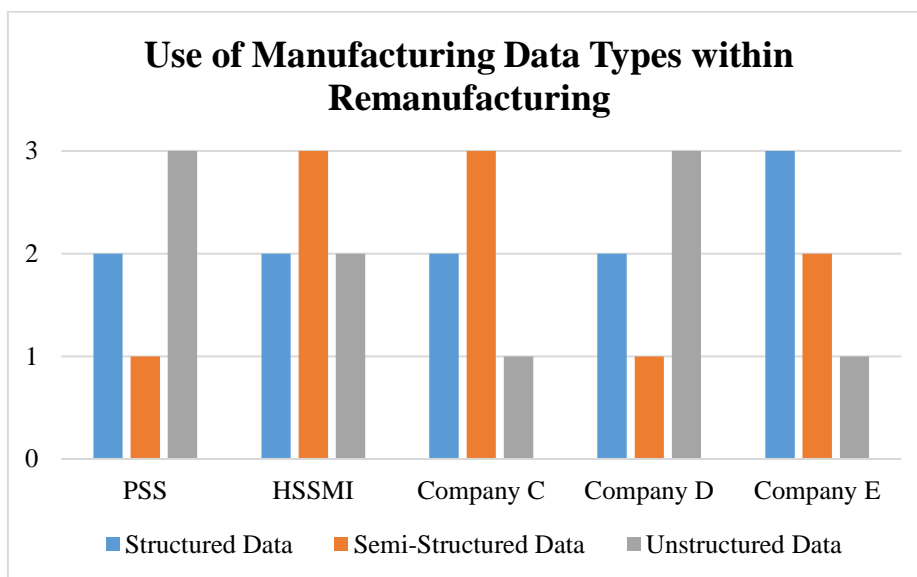

Fig 5: Manufacturing Data Types within Remanufacturing.

Respondents were asked to state the level of data type use in their organisations and the responses from the completed forms were tabulated and graphical representation was plotted. For the representations, point “3” (on the X axis) represents “high”, point “2” represents “medium” while point “1” represents low, in terms of volume of data type usage in each of the company. At first glance it is clear to see that HSSMI and Company C utilize more semi-structured data sets, unlike PSS, Company D and Company E, all companies engaged in traditional remanufacturing. As data changes, it is expected that the procedure for making use of it for internal decisions will change. [42] gives an example of this change through data-driven decision making framework for remanufacturing. Currently, PSS and Company D, both third party remanufacturers engage in remanufacturing of mechanical and electrical automobile remanufacturing employing unstructured manufacturing data sets such as data embedded in manufacturer’s manual, operations data of products in MS excel files.

## 4.2 Manufacturing Data and Remanufacturing Parameters.

Responses from the interviewees indicates that manufacturing data type are likely to have an impact on the parameters employed in remanufacturing and this was evident from the semi-structured interviews results. With traditional remanufacturing, remanufacturing parameters revolve around the broad process of remanufacturing and external influence on remanufacturing, such as distance between the OEM and the third party remanufacturer, distance between third party remanufacturer and suppliers, etc. For data-driven remanufacturing, where the product functions within an IoT system and framework, the amount of data created with every interactions from sensor capture, invariably increases the remanufacturing parameters. As captured from the semi-structured interview, the following are the broad remanufacturing parameters driven for data-driven remanufacturing for the RESS device;

- Battery temperature, (°C)
- Battery voltage (v)
- Battery current during run (A)
- Air flow (CFM)
- Vibration Data captured in the battery cage (Hz)
- Battery Inlet Pressure (PA)
- Distance from OEM to remanufacturer. (km)
- Distance of remanufacturers to spares supplier.(km)

The battery management system, or BMS captures these information from the RESS as operations data and this data is logged on the BMS. This data gives the degradability information of the RESS and can be used for end of life design and approaches, such as remanufacturing. Manufacturing data from sensors are also able to provide greater visibility on the entire reverse logistics supply chain which also improves on remanufacturing quality. Thus, the more the remanufacturing parameters, the greater the quality of remanufactured products, as proposed in Figure 6.

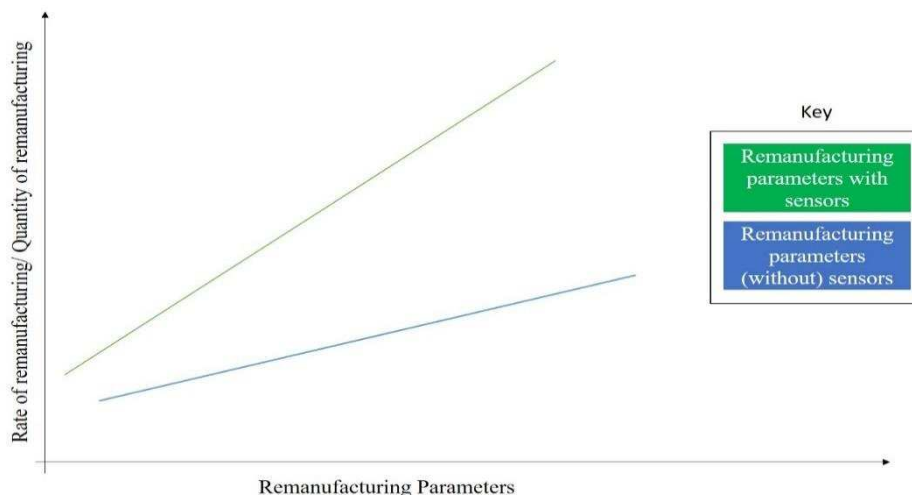

Figure 6: Relationship between rate and quality of remanufacturing and remanufacturing parameters

## 5 Discussions and Conclusions

This paper explains how manufacturing data acquired from embedded sensors enables remanufacturing parameters and remanufacturing. The object considered is the Rechargeable Energy Storage System or RESS, the battery system of supercapacitors utilized in Hybrid and Electric Vehicles. Manufacturing data utilized in remanufacturing operations were identified in semi-structured interviews with key stakeholders of 5 firms involved in remanufacturing and remanufacturing related research. The Battery Management System or BMS was deployed to capture data from the RESS device and data which was deemed useful for remanufacturing was noted as remanufacturing parameters.

From the interviews it was found that decision-making in remanufacturing today is largely driven by intuition and experience and less manufacturing data reliant. Persons involved in remanufacturing, from key decision makers to operators had developed knowledge on what were set routines for remanufacturing. However, this changes when the product remanufacturing has other possible functions –that is, not just being able to be assembled, cleaned and reassembled, but is able to utilize sensors on it for data capture. For decision-making, the process is faster and less wasteful. More importantly, these new manufacturing data from sensors are able to enable the remanufacturing process by identifying new and useful parameters to improve remanufacturability. Two conclusions from this research are found: adopting more remanufacturing parameters through the use of sensors is able to increase the rate of remanufacturing and is able to improve the quality of the remanufactured goods, as opposed to the traditional remanufacturing where traditional data analytics are performed on unstructured data sets/type. The result is similar to the end of life approach on machines known as condition-based maintenance, where data gathered from sensors have been seen to extend the life cycle of these machines in comparison to what was previously obtainable through unstructured data and knowledge by intuition and experience [34]. The graph in Figure 6 graph is plotted to show the relationship between the rate of remanufacturing and remanufacturing parameters. Also, parameters secured from sensors can contribute to understanding the CO<sub>2</sub> emissions consumed across the entire remanufacturing supply chain –that is from product supply from the OEM to the third party remanufacturer to the delivery of remanufactured component. This is important in understanding the entire sustainability of remanufacturing.

As identified in the interviews, there would be possible tradeoffs, for example between rate of remanufacturing returns and quality. Finding a balance within the concept of big data will be key. It should be noted that the interviews was conducted between 5 different firms involved, to varying degrees, with remanufacturing. Future studies on

this subject would require more participants for scientific validity and a scientific validation of results identified. Increasing the scope of the stakeholders contacted for the semi-structured interview is likely to add value to the discussion as well as holding, for instance, focus groups.

For a future study, it would be of interest to understand what particular requirements of Big Data support remanufacturing parameters –is it volume, variety, or velocity? Do they support these equally or with varying degrees? Are there any other characteristics of Big Data that have been overlooked by are equally important? How do these add to, for instance, the overall sustainability of the remanufacturing process where variable such as CO<sub>2</sub> emissions on the reverse logistics supply chain are considered? A question is, “does this result apply to other key components of the EVs, such as the fuel cells?” Future research will also involve collection of live data containing these parameters over a stated period of time and the development of models and frameworks, after data analysis, to support useful relationships.

## 6 Acknowledgements

This study has been supported by Connected Everything: Industrial Systems in the Digital Age, a UK EPSRC research partner. The work presented in this paper was carried out with the involvement of Riversimple, PSS and HSSMI and two other firms involved in remanufacturing who wishes to remain anonymous. Their support is most gratefully acknowledged.

## References:

1. O. Okorie, C. Turner, F. Charnley, M. Moreno AT. A review of data driven approaches for Circular Economy in manufacturing. 18th European Roundtable for Sustainable Consumption and Production, ERSCP. Skiathos Island, Greece: 18th European Roundtable for Sustainable Consumption and Production, ERSCP.; 2017. pp. 120–131.
2. Goodall P., Rosamond E., Harding J. A review of the state of the art in tools and techniques used to evaluate remanufacturing feasibility. *Journal of Cleaner Production*. 2014; 81: 1–15. Available at: DOI:10.1016/j.jclepro.2014.06.014
3. Ismail HN., Zwolinski P., Mandil G., Brissaud D. Decision Making System for Designing Products and Production Systems for Remanufacturing Activities. *Procedia CIRP*. 2017; 61: 212–217. Available at: DOI:10.1016/j.procir.2016.11.231
4. Nenes G., Panagiotidou S., Dekker R. Inventory control policies for inspection and remanufacturing of returns: A case study. *International Journal of Production Economics*. Elsevier; 2010; 125(2): 300–312. Available at: DOI:10.1016/j.ijpe.2010.02.008
5. Poles R. System Dynamics modelling of a production and inventory system for remanufacturing to evaluate system improvement strategies. *International Journal of Production Economics*. Elsevier; 2013; 144(1): 189–199. Available

- at: DOI:10.1016/j.ijpe.2013.02.003
6. Da Q SHZH. Simulation of remanufacturing in reverse supply chain based on system dynamics. 2008 International Conference on Service Systems and Service Management. 2008; : 1–6. Available at: DOI:10.1109/ICSSSM.2008.4598447
  7. Taticchi P., Garengo P., Nudurupati SS., Tonelli F., Pasqualino R. A review of decision-support tools and performance measurement and sustainable supply chain management. *International Journal of Production Research*. 2015; 53(21): 6473–6494. Available at: DOI:10.1080/00207543.2014.939239
  8. Abdulrahman MDA., Subramanian N., Liu C., Shu C. Viability of remanufacturing practice: A strategic decision making framework for Chinese auto-parts companies. *Journal of Cleaner Production*. Elsevier Ltd; 2015; 105: 311–323. Available at: DOI:10.1016/j.jclepro.2014.02.065
  9. Subramoniam R., Huisingh D., Chinnam RB., Subramoniam S. Remanufacturing Decision-Making Framework (RDMF): Research validation using the analytical hierarchical process. *Journal of Cleaner Production*. 2013; 40: 212–220. Available at: DOI:10.1016/j.jclepro.2011.09.004
  10. Ijomah WL. Addressing decision making for remanufacturing operations and design-for-remanufacture. *International Journal of Sustainable Engineering*. 2009; 2(2): 91–102. Available at: DOI:10.1080/19397030902953080
  11. Sundin E. Product and process design for successful remanufacturing. *Science And Technology*. 2004. 1-160 p.
  12. Koch V., Kuge S., Geissbauer R., Schrauf S. Industry 4.0 - Opportunities and challenges of the industrial internet. *strategy& Formerly Booz & Company, PwC*. 2014; 13: 1–51.
  13. Lund RT and BM. Remanufacturing: The experience of the United States and implications for developing countries. 1984; (31): 126. Available at: <http://documents.worldbank.org/curated/en/792491468142480141/Remanufacturing-the-experience-of-the-United-States-and-implications-for-developing-countries>
  14. Geissdoerfer M., Savaget P., Bocken NMP., Hultink EJ. Review: The Circular Economy – A new sustainability paradigm? *Journal of Cleaner Production*. 2017; 143(January): 757–768. Available at: DOI:10.1016/j.jclepro.2016.12.048.CITATION
  15. Enang W., Bannister C. Modelling and control of hybrid electric vehicles (A comprehensive review). *Renewable and Sustainable Energy Reviews*. Elsevier Ltd; 2017; 74(March): 1210–1239. Available at: DOI:10.1016/j.rser.2017.01.075
  16. Korhonen J., Honkasalo A., Seppälä J. Circular Economy: The Concept and its Limitations. *Ecological Economics*. 2018; 143: 37–46. Available at: DOI:10.1016/j.ecolecon.2017.06.041
  17. Santillo D. Reclaiming the Definition of Sustainability (7 pp). *Environmental Science and Pollution Research - International*. 2007; 14(1): 60–66. Available at: DOI:10.1065/espr2007.01.375
  18. Golinska P., Kuebler F. The method for assessment of the sustainability

- maturity in remanufacturing companies. *Procedia CIRP*. Elsevier B.V.; 2014; 15: 201–206. Available at: DOI:10.1016/j.procir.2014.06.018
19. Clark WC., Crutzen PJ., Schellnhuber HJ. *Science for Global Sustainability: Toward a New Paradigm*. CID Working Paper No.120. 2005. Available at: <http://www.cid.harvard.edu/cidwp/120.htm>
  20. Nasr N., Thurston M. *Remanufacturing : A Key Enabler to Sustainable Product Systems*. *Proceedings of LCE*. 2006; : 15–18.
  21. Ijomah WL., McMahon CA., Hammond GP., Newman ST. Development of design for remanufacturing guidelines to support sustainable manufacturing. *Robotics and Computer-Integrated Manufacturing*. 2007; 23(6): 712–719. Available at: DOI:10.1016/j.rcim.2007.02.017
  22. Das HS., Tan CW., Yatim AHM. Fuel cell hybrid electric vehicles: A review on power conditioning units and topologies. *Renewable and Sustainable Energy Reviews*. Elsevier Ltd; 2017; 76(January 2016): 268–291. Available at: DOI:10.1016/j.rser.2017.03.056
  23. Wilberforce T., El-Hassan Z., Khatib FN., Al Makky A., Baroutaji A., Carton JG., et al. Developments of electric cars and fuel cell hydrogen electric cars. *International Journal of Hydrogen Energy*. Elsevier Ltd; 2017; 42(40): 25695–25734. Available at: DOI:10.1016/j.ijhydene.2017.07.054
  24. Kouchachvili L., Yaïci W., Entchev E. Hybrid battery/supercapacitor energy storage system for the electric vehicles. *Journal of Power Sources*. 2018; 374(November 2017): 237–248. Available at: DOI:<https://doi.org/10.1016/j.jpowsour.2017.11.040>
  25. Oudemir O., Gupta SM. Computers in Industry Quality management in product recovery using the Internet of Things : An optimization approach. *Computers in Industry*. Elsevier B.V.; 2014; 65(3): 491–504. Available at: DOI:10.1016/j.compind.2013.11.006
  26. Ilgin MA., Gupta SM. Evaluating the impact of sensor-embedded products on the performance of an air conditioner disassembly line. *International Journal of Advanced Manufacturing Technology*. 2011; 53(9–12): 1199–1216. Available at: DOI:10.1007/s00170-010-2891-0
  27. Hatcher GD., Ijomah WL., Windmill JFC. Design for remanufacture: A literature review and future research needs. *Journal of Cleaner Production*. Elsevier Ltd; 2011; 19(17–18): 2004–2014. Available at: DOI:10.1016/j.jclepro.2011.06.019
  28. Fang H.C., Ong S., Nee AY. Use of Embedded Smart Sensors in Products to Facilitate Remanufacturing. In: Nee AY. (ed.) *Handbook of Manufacturing and Engineering Technology*. Springer-Verlag; 2015. pp. 3265–3290. Available at: [https://link.springer.com/referenceworkentry/10.1007%2F978-1-4471-4670-4\\_85](https://link.springer.com/referenceworkentry/10.1007%2F978-1-4471-4670-4_85)
  29. Shrouf F., Ordieres J., Miragliotta G. Smart factories in Industry 4.0: A review of the concept and of energy management approached in production based on the Internet of Things paradigm. 2014 IEEE International Conference on Industrial Engineering and Engineering Management. 2014; : 697–701. Available at: DOI:10.1109/IEEM.2014.7058728

30. M K., WM G., C H., A H. Sensor-based data recording of use conditions for product takeback. Proceedings of the 1998 I.E. international symposium on electronics and the environment. Chicago; 1998. pp. 138–143.
31. S C., M A., M P., van Oers LFCM. Sensor system selection for prognostics and health monitoring. Proceedings of the ASME 2008 international design engineering technical conferences & computers and information in engineering conference. Brooklyn; 2008. pp. 1383–1389.
32. G S., A B., U K. Enhanced product functionality with life cycle units. Proceedings of the Institution of Mechanical Engineers, Part B: Journal of Engineering Manufacture. 2003; 217(9): 1197–1202.
33. Hatcher GD., Ijomah WL., Windmill JFC. Integrating design for remanufacture into the design process: The operational factors. Journal of Cleaner Production. Elsevier Ltd; 2013; 39: 200–208. Available at: DOI:10.1016/j.jclepro.2012.08.015
34. Jardine AKS., Lin D., Banjevic D. A review on machinery diagnostics and prognostics implementing condition-based maintenance. Mechanical Systems and Signal Processing. 2006; 20(7): 1483–1510. Available at: DOI:10.1016/j.ymsp.2005.09.012
35. Perry N., Bernard A., Laroche F., Pompidou S. Improving design for recycling - Application to composites. CIRP Annals - Manufacturing Technology. 2012; 61(1): 151–154. Available at: DOI:10.1016/j.cirp.2012.03.081
36. Vanegas P., Peeters JR., Cattrysse D., Tecchio P., Ardente F., Mathieux F., et al. Ease of disassembly of products to support circular economy strategies. Resources, Conservation and Recycling. 2017; (June). Available at: DOI:10.1016/j.resconrec.2017.06.022
37. Charter M., Gray C. Remanufacturing and product design. International Journal of Product Development. 2008; 6(3/4): 375. Available at: DOI:10.1504/IJPD.2008.020406
38. Robson C. Real World Research: A Resource for Social Scientists and Practitioner-Researchers. 2nd edn. Blackwell Publishing; 2002.
39. King N. The Qualitative Research Interview. In: Cassel C, Symon G (eds.) In Qualitative methods in organizational research: A practical guide. Sage Publications, London; 1994. p. 253.
40. Gartner. Gartner Says 4.9 Billion Connected ‘Things’ Will Be in Use in 2015. Gartner Press Release. 2014. Available at: <http://www.gartner.com/newsroom/id/2905717> (Accessed: 17 July 2017)
41. Intel Corporation. Optimizing manufacturing with the internet of things. Intel Corporation. 2014. Available at: <http://www.intel.com/content/www/us/en/internet-of-things/white-papers/industrial-optimizing-manufacturing-with-iot-paper.html> (Accessed: 17 August 2016)
42. Okorie O., Turner C., Salonitis K., Charnley F., Moreno M., Tiwari A. A Decision-Making Framework for the Implementation of Remanufacturing in Rechargeable Energy Storage System in Hybrid Vehicles. 8th Swedish Production Symposium, SPS 2018, Stockholm, Sweden. 2018. pp. 16–18.