



Deposited via The University of Leeds.

White Rose Research Online URL for this paper:

<https://eprints.whiterose.ac.uk/id/eprint/137970/>

Version: Accepted Version

---

**Article:**

Lanks, CW, Sue, DY and Rossiter, HB (2019) A Pickwickian Problem: How is Breathing Controlled? *Annals of the American Thoracic Society*, 16 (1). pp. 138-143. ISSN: 2329-6933

<https://doi.org/10.1513/AnnalsATS.201806-411CC>

---

Copyright (c) 2019 by the American Thoracic Society. This is an author produced version of a paper published in *Annals of the American Thoracic Society*. Uploaded in accordance with the publisher's self-archiving policy.

**Reuse**

Items deposited in White Rose Research Online are protected by copyright, with all rights reserved unless indicated otherwise. They may be downloaded and/or printed for private study, or other acts as permitted by national copyright laws. The publisher or other rights holders may allow further reproduction and re-use of the full text version. This is indicated by the licence information on the White Rose Research Online record for the item.

**Takedown**

If you consider content in White Rose Research Online to be in breach of UK law, please notify us by emailing [eprints@whiterose.ac.uk](mailto:eprints@whiterose.ac.uk) including the URL of the record and the reason for the withdrawal request.

## **A Pickwickian Problem: How is Breathing Controlled?**

Lanks CW<sup>1</sup>, Sue DY<sup>1</sup>, Rossiter HB<sup>1,2,3</sup>

<sup>1</sup>Division of Respiratory and Critical Care Physiology and Medicine, Harbor-UCLA Medical Center,  
Torrance, CA 90509

<sup>2</sup>Rehabilitation Clinical Trials Center, Los Angeles Biomedical Research Institute at Harbor-UCLA Medical  
Center, Torrance, CA 90502

<sup>3</sup>Faculty of Biological Sciences, University of Leeds, Leeds LS2 9JT, UK

### **Corresponding Author:**

Charles Lanks, M.D.

Harbor-UCLA Medical Center

1000 W. Carson Street, Box 405

Torrance, CA 90509

Email: [CLanks@dhs.lacounty.gov](mailto:CLanks@dhs.lacounty.gov)

Fax: 310-328-9849

**Sources of funding:** none

**Conflicts of interest:** no disclosures or conflicts of interest

**Word count:** 2661

## The Clinical Challenge

A 47-year-old man with super-morbid obesity (BMI = 81 kg/m<sup>2</sup>) presented to the emergency department with leg swelling and mild dyspnea. The leg swelling was long standing, but had increased over the course of one month to the point that ambulation had become difficult. His dyspnea was progressive over the course of one week and was significantly worse with exertion. He reported no associated cough, fever, chest discomfort or pleurisy. He was a lifelong non-smoker. His initial temperature was 36.8 °C, blood pressure 122/75 mmHg, heart rate 118 beats/minute, respiratory rate 16 breaths/minute, and oxygen saturation by pulse oximetry was 75% while breathing ambient air. His mental status was fully intact during his initial examination and auscultation of his chest revealed bibasilar rales and distant breath sounds. His cardiovascular examination was limited by body habitus, but S1 and S2 were normal without appreciable extra heart sounds. There was no appreciable jugular venous distension. His extremity examination was notable for symmetric 3+ pitting edema in both legs extending to his upper thighs. Laboratory studies were: sodium 139 mM, potassium 4.5 mM, chloride 97 mM, bicarbonate 33 mM, blood urea nitrogen 17 mM, creatinine 0.97 mM. Although no blood gas was obtained at the time of presentation, the patient's elevated serum bicarbonate suggested chronic, mild hypercapnia. His chest radiograph was extremely poor in quality due to body habitus and the lung fields were judged to be uninterpretable.

In response to his low oxygen saturation, supplemental oxygen was given via nasal cannula at 2 liters/min. The patient's follow-up saturation was 98%. Approximately 30 minutes later, he became somnolent. An arterial blood gas revealed a pH of 7.11, PaCO<sub>2</sub> of 99 mmHg, and PaO<sub>2</sub> of 159 mmHg (Table 1). The patient was intubated and mechanically ventilated with a tidal volume of 450 mL, F<sub>i</sub>O<sub>2</sub> 1.0, PEEP 5 cm H<sub>2</sub>O, and respiratory rate 16 breaths/min. He was treated with furosemide in 40 mg to 80 mg intravenous doses given up to three times daily, which elicited an appropriate increase in urine output. Over the following 10 days, the patient had a net negative fluid balance of more than 40 liters, and the

serum bicarbonate concentration ( $[\text{HCO}_3^-]$ ) increased from 33 to 44 mM. Weaning from mechanical ventilation was complicated by persistence of hypercapnia during spontaneous breathing trials. Although trials were not aborted due to low respiratory rate or tidal volume,  $\text{PaCO}_2$  was  $>80$  mmHg and extubation was considered unsafe.

### Questions

- *What was the underlying cause of the patient's chronic hypercapnia?*
- *What was the most likely mechanism of the acute ventilatory decompensation in the emergency department?*
- *Did furosemide exacerbate hypercapnia and impede weaning from the ventilator?*

### Clinical Reasoning

Obesity hypoventilation syndrome (OHS) is defined by the combination of obesity (BMI  $>30$  kg/m<sup>2</sup>) and awake hypoventilation ( $\text{PaCO}_2 >45$  mmHg) in the absence of other causes of hypoventilation. The condition was originally coined Pickwickian Syndrome (Burwell et al., 1956) after the obese, somnolent character "Joe" in Charles Dickens' 1837 *The Posthumous Papers of the Pickwick Club*. The recognition and diagnosis of OHS is often confounded by the presence of multiple comorbidities at the time of patients' first healthcare contact. *In extremis*, patients with OHS become increasingly hypercapnic due to the inability to appropriately eliminate  $\text{CO}_2$ . In many cases of OHS, hypoxemia is responsible for a greater proportion of ventilatory drive. As a clinician, the instinct is to treat the immediate threat, which typically means reversal of hypoxemia and diuresis. Both interventions, while necessary, may produce further problems in OHS that provide a renewed threat of danger.

The patient's initial rapid decompensation was ultimately attributed to administration of supplemental oxygen resulting in an excessive rise in PaO<sub>2</sub> that contributed to acute on chronic hypercapnia. Following initiation of mechanical ventilation, the patient's PaCO<sub>2</sub>, arterial pH and mental status progressed towards normal. The rapid reduction in plasma volume following furosemide administration combined with underlying chronic bicarbonate retention exacerbated his metabolic alkalosis. The acute metabolic alkalosis superimposed upon the physiological effects of a chronic hypercapnia made it difficult to achieve acceptable levels of PaCO<sub>2</sub> during spontaneous breathing trials and prolonged the patient's time on the ventilator.

### **The Clinical Solution**

Oxygenation goals were adjusted and FiO<sub>2</sub> was titrated to a target oxygen saturation of 88-92% by pulse oximetry, resulting in a PaO<sub>2</sub> of 55-65 mmHg. The failed weaning attempts were treated with acetazolamide to combat iatrogenic metabolic alkalosis. Acetazolamide, a carbonic anhydrase inhibitor that increases the elimination of bicarbonate in the proximal renal tubule, was administered in 250 mg oral doses twice daily and reduced the patient's serum [HCO<sub>3</sub><sup>-</sup>] from 46 to 36 mM over the course of several days (Table 1), following which he was successfully extubated.

### **The Science Behind the Solution**

The control of breathing is complex. It requires integration of a sensory system, a central controlling system, and an effector system (Figure 1). During resting breathing, afferent signaling to the respiratory controller from the carotid bodies, central chemoreceptors, pulmonary receptors, and mechanoreceptors in the chest wall are integrated in the medulla, which, together with (a still poorly

understood) input from an intrinsic 'central pattern generator,' effect a ventilatory drive in the form of cortical respiratory motor outflow. This neural stimulation acts on the effector system – the respiratory muscles – through excitation-contraction coupling, to bring about a coordinated inhalation and exhalation pattern. This control system aims to maintain normal arterial  $PO_2$  and  $PCO_2$ . A disadvantaged effector system, dysregulation of ventilatory control, and disrupted sensory systems all contribute to the pathophysiological abnormalities underlying OHS.

### ***Obesity and Hypercapnia***

Obese individuals are at a significant ventilatory disadvantage. First, total cellular  $CO_2$  production, and therefore the requirement for  $CO_2$  output by ventilation, can be 20 to 30% higher in individuals with larger body surface areas. Second, adding weight to the chest and abdomen in the form of adipose tissue reduces chest wall compliance and decreases functional residual capacity, expiratory reserve volume, and, much less commonly, vital and total lung capacities. Low operating lung volumes increase airway resistance and work of breathing and predispose to small airway closure and basal atelectasis, all of which cause an intrapulmonary shunt and contribute to ventilation/perfusion ( $V_A/Q$ ) mismatching. Normally, hypercapnia resulting from  $V_A/Q$  inequality is corrected by increased ventilatory drive that results in increased alveolar ventilation. In OHS, chronic hypoxemia and hypercapnia are the final result of increased airway resistance and chest wall stiffness, while the greater demand for ventilation in the obese individual increases the work of breathing and may drive chronic respiratory muscle fatigue. The resulting compensation in plasma and cerebrospinal fluid (CSF) buffering capacity blunts ventilatory responsiveness to both hypoxemia and hypercapnia and exacerbates the ventilatory control problem. Distribution of adiposity is likely more important than BMI in developing OHS, which can, in many cases, be reversed by weight loss.

Another likely contributor to OHS is leptin insensitivity. Leptin is produced by adipose tissue and acts on the hypothalamus to suppress appetite, but also stimulates ventilation. The carotid body also expresses leptin receptors, increasing its discharge and driving ventilation when stimulated by circulating leptin. While leptin deficiency results in reduced ventilation in animal models, obese individuals are hyperleptinemic. However, a high fat diet and metabolic syndrome appear to be associated with blunted leptin-dependent sensor signaling in animals and blunted hypercapnic responsiveness in patients with OHS.

Collectively, OHS patients are characterized by chronic abnormalities in the chemo- and mechano-sensory systems delivering neural input to the ventilatory controller (Figure 1) which causes reduced ventilatory motor outflow. Finally, the respiratory muscles are also mechanically disadvantaged. The result is a compensated respiratory acidosis, blunted hypoxic, hypercapnic, and leptin sensitivity, mechanical constraint, and hypoventilation.

### ***Chemical and Neural Control of Breathing***

Chemoreceptors are highly specialized cells that respond to changes in the composition of the fluid surrounding them. Chemoreceptors in humans are primarily located in the ventral medulla oblongata (central) and carotid bodies (peripheral). Central chemoreceptors respond to changes in pH and PaCO<sub>2</sub> while peripheral chemoreceptors respond to changes in pH, PaCO<sub>2</sub> and PaO<sub>2</sub> (Figure 1). The highly specialized hemoglobin molecule, with its ability to maintain a high saturation over a wide range of PaO<sub>2</sub> (60-100 mmHg), reduces the need to tightly regulate PaO<sub>2</sub> over the normal physiologic range, and therefore, arterial pH and PaCO<sub>2</sub> are the primary variables regulated by ventilation.

#### *Central Chemoreceptors*

The central chemoreceptors respond to changes in cerebrospinal fluid pH ( $\text{pH}_{\text{CSF}}$ ) rather than the pH of arterial blood. The blood brain barrier isolates these chemoreceptors from the systemic circulation and is relatively, but not completely, impermeable to hydrogen ions ( $\text{H}^+$ ). Carbon dioxide, however, diffuses freely into the CSF, where its chemical combination with  $\text{H}_2\text{O}$  is catalyzed by carbonic anhydrase, yielding dissociated  $\text{HCO}_3^-$  and  $\text{H}^+$  and reducing  $\text{pH}_{\text{CSF}}$  (Figure 2). Because the CSF protein concentration is relatively low, CSF is a poor buffer, and small changes in  $\text{PaCO}_2$  yield large and rapid changes in  $\text{pH}_{\text{CSF}}$ . Chronic retention of  $\text{CO}_2$  is compensated in the CSF by the choroid plexus, which produces and transports  $\text{HCO}_3^-$  into cerebrospinal fluid. CSF  $\text{HCO}_3^-$  retention is a slow process, but if hypercapnia is maintained (as it is in OHS) increased CSF  $[\text{HCO}_3^-]$  leads to a blunted central chemosensitivity. The slope of the linear relationship in Figure 3A represents normal chemoreceptor sensitivity to  $\text{PaCO}_2$  effecting an increase in ventilation. Above a low threshold value, ventilation increases in linear proportion to  $\text{PaCO}_2$ . On the other hand, central chemoreceptors are not sensitive to  $\text{PaO}_2$  (Figure 3B). Under normal conditions, central chemoreceptors are likely responsible for about 80% of the  $\text{CO}_2$  induced drive to breathe.

#### *Peripheral Chemoreceptors*

Peripheral chemoreceptors are found in the carotid bodies located at the bifurcation of the common carotid arteries. Their very high blood flow relative to metabolic rate allows them to accurately detect arterial  $\text{PO}_2$ , pH, and  $\text{PCO}_2$ . The carotid body is unique in its sensitivity to  $\text{PO}_2$ . Nervous output from the carotid body is significantly damped when  $\text{PaO}_2$  exceeds 100 mmHg and is almost silent above ~400-500 mmHg. However, the carotid body response is extremely non-linear, such that firing increases dramatically when  $\text{PaO}_2$  falls below 60 mmHg (Figure 3D).

It has been estimated that only about 20% of the  $\text{CO}_2$  induced drive to breathe is mediated by the carotid bodies. Sensitivity to hypercapnia is increased by hypoxemia and blunted by hyperoxia (Figure

3C). Overall, patients with normal PaO<sub>2</sub> and PaCO<sub>2</sub> derive little ventilatory drive from carotid body outflow. Resection of the carotid bodies results in complete loss of hypoxemic ventilatory sensitivity.

#### *Mechanoreceptors and the work of breathing*

The neural control of breathing is a highly complex interplay among ventilatory pattern generators, efferent outflow, and afferent sensors. Of particular relevance to OHS are type I and II tendon organ (sensing force) and muscle spindle (sensing length) mechanoreceptors in the chest wall muscles, tendons, and joints that provide information about movement of the respiratory muscles (Figure 1). Type III/IV unmyelinated chest wall metaboreceptors also provide information about muscle metabolic strain. Excitation of primary type Ib tendon organs of the internal intercostals has an inhibitory effect on inspiratory neuronal activity in the medulla and this may contribute to the hypoventilation of OHS. However, there is considerable (teleologically advantageous) redundancy in the sensory motor system to the chest wall and a precise understanding of its integrated control awaits discovery.

#### *Combined ventilatory drive*

The combined effect of all receptor stimuli is that ventilatory drive increases linearly once PaCO<sub>2</sub> exceeds 35 mmHg (Figure 4A). Ventilatory drive from hypercapnia is increased with hypoxemia by reducing the threshold for increased ventilation (>30 mmHg), causing greater ventilation for a given PaCO<sub>2</sub>, and increasing the sensitivity to PaCO<sub>2</sub> (steeper slope). Metabolic acidosis and metabolic alkalosis change the threshold for ventilation without significantly changing sensitivity to PaCO<sub>2</sub> (Figure 4B). Conversely, ventilation is blunted when the work of breathing is high. This reduces the effective PaCO<sub>2</sub> sensitivity due to reduced airway pressure generation for a given ventilatory motor outflow.

#### ***The Effect of Hypoxemia***

Supplemental oxygen has been used to treat respiratory failure for over 100 years. More recently, oxygen therapy has been recognized as a “double-edged sword” in several disease states. OHS is typically accompanied by chronic hypoxemia and the immediate medical response is to provide supplemental oxygen. However, hypoxemia typically augments the overall ventilatory drive in these patients by increasing peripheral chemoreceptor outflow and reducing threshold and increasing sensitivity to PaCO<sub>2</sub> (Figure 5B). Providing supplemental O<sub>2</sub>, however, does just the opposite. In newly diagnosed OHS patients, breathing 100% oxygen for 20 minutes effectively silences peripheral chemoreceptor activity and can increase PaCO<sub>2</sub> by as much as 10 mmHg. If pulmonary perfusion is unchanged, more blood flow to low V<sub>A</sub>/Q regions causes less blood flow to high V<sub>A</sub>/Q regions. This further increases the V<sub>A</sub>/Q of these regions, which increases alveolar and physiologic dead space. This, in turn, leads to a higher PCO<sub>2</sub> for a given minute ventilation. For a patient already in respiratory distress, this can be devastating.

In our patient, the pathologic PaCO<sub>2</sub> insensitivity at the time of presentation (Figure 5A) was at least partially counteracted by increased ventilatory stimulus from hypoxemia (Figure 5B), but this stimulus was removed by increasing his PaO<sub>2</sub> (Figure 5C). In severe states of hypoxemia, supplemental O<sub>2</sub> should be provided to avoid tissue hypoxia and metabolic acidosis, but providing supplemental O<sub>2</sub> in excess of that required to maintain an appropriate rate of oxygen delivery (88-92% hemoglobin saturation) may have the dramatic and unwanted effect of ventilatory depression.

Apart from altering chemoreceptor sensitivity, supplemental oxygen may worsen hypercapnia in two other ways. First, correcting local hypoxia in the lungs reverses pulmonary vasoconstriction in areas of low V<sub>A</sub>/Q. The increased blood flow to these poorly-ventilated regions adds more blood with low PO<sub>2</sub> and high PCO<sub>2</sub> to the systemic circulation. Second, oxygen decreases the affinity of hemoglobin for CO<sub>2</sub> (the Haldane effect), thereby increasing the PCO<sub>2</sub> for a given blood CO<sub>2</sub> content. The degree to which each of these three factors contributes to O<sub>2</sub>-induced hypercapnia may vary from patient to patient

depending upon the level of initial hypoxemia and intrinsic differences in ventilatory and pulmonary vascular responsiveness to changes in O<sub>2</sub> and CO<sub>2</sub>.

### ***Diuresis, Metabolic Alkalosis and Ventilatory Suppression***

In our patient, compensation for the chronic respiratory acidosis caused by hypoventilation resulted in bicarbonate retention. Substantial volume removal with a loop diuretic precipitated a metabolic alkalosis through “contraction.” Urine eliminated through the kidneys contains very little HCO<sub>3</sub><sup>-</sup>. Therefore, as the extravascular volume “contracts” with a loop diuretic-mediated diuresis, it does so around a relatively constant HCO<sub>3</sub><sup>-</sup> content and the blood HCO<sub>3</sub><sup>-</sup> concentration increases. Additionally, inhibition of sodium reabsorption in the ascending limb of the renal tubule leads to increased sodium delivery in the distal tubule. This prompts potassium and hydrogen ion excretion in exchange for sodium resorption. Metabolic alkalosis affects the threshold response to PaCO<sub>2</sub> so that at a constant PaCO<sub>2</sub> in a mechanically ventilated patient, the drive to breath is reduced (Figure 5D).

With the generation of an iatrogenic metabolic alkalosis, our patient did not increase his ventilatory drive during spontaneous breathing trials except when PaCO<sub>2</sub> was very high. Acetazolamide, a carbonic anhydrase inhibitor, was used to stimulate renal elimination of bicarbonate and, once serum [HCO<sub>3</sub><sup>-</sup>] was reduced, a more normal ventilatory response to PaCO<sub>2</sub> was restored. With the correction of other patient factors contributing to difficult weaning, our patient was extubated safely and discharged from intensive care. It should be noted that the routine use of carbonic anhydrase inhibitors as respiratory stimulants in mechanically ventilated patients is not recommended.

### **Conclusion**

Patients with the obesity hypoventilation syndrome commonly present to the hospital with hypoxemia, hypercapnia, and respiratory distress. While the initial presentation is typically characterized by insensitivity to PaCO<sub>2</sub>, their hospital course can be negatively affected by iatrogenic complications. These include overcorrection of hypoxemia and induction of “contraction” metabolic alkalosis by large volume diuresis with loop diuretics. Understanding the physiologic mechanisms behind not only the underlying disease, but the complications that can occur during treatment, is fundamental to the appropriate treatment of OHS. These include judicious titration of supplemental oxygen and careful correction of hypervolemia by appropriate selection of diuretic agents.

## Recommended Reading

Lazarus, S. C., Ernst, J. D., King, T. E., Broaddus, V. C., Murray, J. F. 1., Nadel, J. A., . . . Mason, R. J. (2016). *Murray & Nadel's textbook of respiratory medicine* (Sixth edition.). Philadelphia, PA: Elsevier/Saunders.

Duffin J. Role of acid-base balance in the chemoreflex control of breathing. *J Appl Physiol*. 2005 Dec;99(6):2255-65.

Piper AJ, Grunstein RR. *Obesity hypoventilation syndrome: mechanisms and management*. *Am J Respir Crit Care Med*. 2011 Feb 1;183(3):292-8.

Manthous CA, Mokhlesi B. *Avoiding Management Errors in Patients with OHS*. *Ann Am Thorac Soc*. 2016 Jan;13(1):109-14.

Wijesinghe M, Williams M, Perrin K, Weatherall M, Beasley R. *The effect of supplemental oxygen on hypercapnia in subjects with obesity associated hypoventilation*. *Chest*. 2011 May;139(5):1018-24.

Jones RL, Nzekwu MM. The effects of body mass index on lung volumes. *Chest*. 2006;130:827–33.

Collins LC, Hoberty PD, Walker JF, Fletcher EC, Peiris AN. The effect of body fat distribution on pulmonary function tests. *Chest*. 1995;107:1298–302

Hakala K, Stenius-Aarniala B, Sovijarvi A. Effects of weight loss on peak flow variability, airways obstruction, and lung volumes in obese patients with asthma. *Chest*. 2000;118:1315–21.

Ladosky W, Botelho MA, Albuquerque JP., Jr Chest mechanics in morbidly obese non-hypoventilated patients. *Respir Med*. 2001;95:281–6.

Koenig SM. Pulmonary complications of obesity. *Am J Med Sci*. 2001;321:249–79

Zwillich CW, Sutton FD, Pierson DJ, Greagh EM, Weil JV. Decreased hypoxic ventilatory drive in the obesity-hypoventilation syndrome. *Am J Med*. 1975;59:343–8

Perez de Llano LA, Golpe R, Ortiz Piquer M, Veres Racamonde A, Vazquez Caruncho M, Caballero Muinelos O, et al. Short-term and long-term effects of nasal intermittent positive pressure ventilation in patients with obesityhypoventilation syndrome. *Chest*. 2005;128:587–94.

Biscoe TJ, Purves MJ, Sampson SR. The frequency of nerve impulses in single carotid body chemoreceptor afferent fibres recorded in vivo with intact circulation. *J Physiol*. 1970 May;208(1):121-31.

Campo A, Fruhbeck G, Zulueta JJ, Iriarte J, Seijo LM, Alcaide AB, et al. Hyperleptinaemia, respiratory drive and hypercapnic response in obese patients. *Eur Respir J*. 2007;30:223–31.

Riberio MJ, et al. High fat diet blunts the effects of leptin on ventilation and on carotid body activity. *J Physiol*. 2017 Dec 22. doi: 10.1113/JP275362.

Haldane JS. The therapeutic administration of oxygen. *Br Med J*. 1917 Feb 10;1(2928):181-3.

Adamson R, Swenson ER. Acetazolamide Use in Severe Chronic Obstructive Pulmonary Disease. Pros and Cons. *Ann Am Thorac Soc*. 2017 Jul;14(7):1086-1093

**Table 1 – Arterial blood gas (ABG) values during the patient’s hospital course.**

	<b>pH</b>	<b>PaCO<sub>2</sub> (mmHg)</b>	<b>PaO<sub>2</sub> (mmHg)</b>	<b>Bicarbonate (mmol/L)</b>
<b>After O<sub>2</sub></b>	7.11	99	159	31
<b>After furosemide</b>	7.41	73	66	44
<b>Failed spontaneous breathing trial</b>	7.37	82	87	46
<b>After acetazolamide</b>	7.42	57	72	36

## Figure Legend

**Figure 1.** Ventilatory drive as a negative feedback loop. Changes in  $PO_2$  are sensed by peripheral chemoreceptors (located in the carotid bodies) while changes in  $PCO_2$  are sensed in both the peripheral and central chemoreceptors (located in the medulla). Chest wall mechanoreceptors produce afferent feedback to the respiratory control center in the medulla. The central chemoreceptors are responsible for approximately 80% of input to controllers in the brainstem which in turn stimulate effectors in the periphery. (CSF = cerebrospinal fluid, BBB = blood brain barrier)

**Figure 2.** Central chemoreceptors are indirectly affected by serum  $PCO_2$ . Because hydrogen ions cannot cross the blood brain barrier, central chemoreceptors are unaffected by arterial pH. Instead,  $CO_2$  diffuses into the CSF where it dissociates into  $H^+$  and  $HCO_3^-$ . Low pH in the cerebrospinal fluid then triggers increased ventilatory drive in the central chemoreceptors. (C = central chemoreceptor)

**Figure 3.** A) The linear relationship between  $PCO_2$  and respiratory drive in central chemoreceptors. The slope of this line represents  $CO_2$  sensitivity. B) Ventilatory drive is unaffected by  $PO_2$  in central chemoreceptors. C) The linear relationship between  $PCO_2$  and ventilatory drive in peripheral chemoreceptors.  $CO_2$  sensitivity (slope) is increased in hypoxemia and decreased in hyperoxia. D) The curvilinear relationship between  $PO_2$  and respiratory stimulation in peripheral chemoreceptors. Rapid triggering is stimulated at  $PO_2$  below 55-60 mmHg.

**Figure 4.** A) The combined effect of central and peripheral chemoreceptors on ventilatory drive. Owing to the effect of  $PO_2$  on peripheral receptors,  $CO_2$  sensitivity is increased in hypoxemia and decreased in hyperoxia. B) Metabolic acidosis and alkalosis do not significantly affect  $CO_2$  sensitivity, but do change the x-intercept.

**Figure 5.** A) At presentation, the central chemoreceptors of OHS patients (red line) have decreased  $CO_2$  sensitivity compared to individuals with normal ventilatory drive. Central ventilatory drive is lower for a

given  $\text{PaCO}_2$  in OHS (red dot) compared to normal (black dot). B) In states of hypoxemia ( $\text{PO}_2 < 60$  mmHg)  $\text{CO}_2$  sensitivity is increased (red line). As a result, peripheral ventilatory drive is higher for a given  $\text{PaCO}_2$  in OHS (red dot) compared to normal (black dot). C) With overcorrection of hypoxemia to 160 mmHg,  $\text{CO}_2$  sensitivity is decreased from normal (red line) and  $\text{PaCO}_2$  increases (red dot). D) In metabolic alkalosis,  $\text{CO}_2$  sensitivity is not affected, but the entire line is shifted to the right (red line) and  $\text{PaCO}_2$  increases (red dot). (OHS = obesity hypoventilation syndrome)

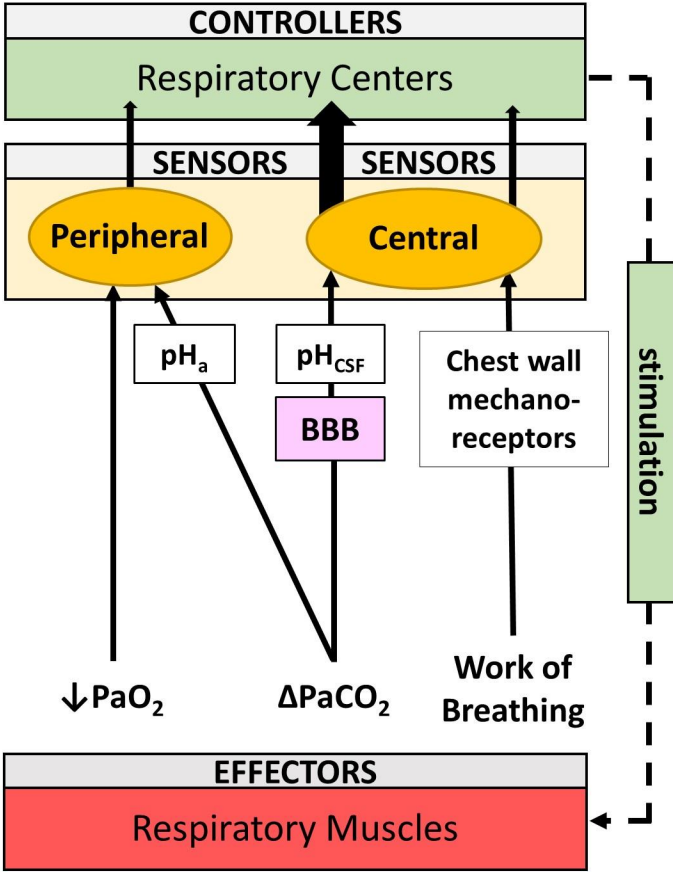

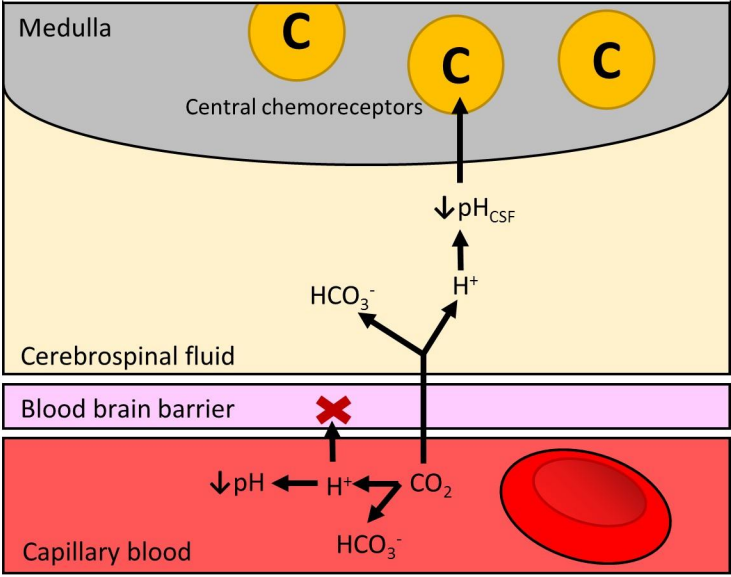

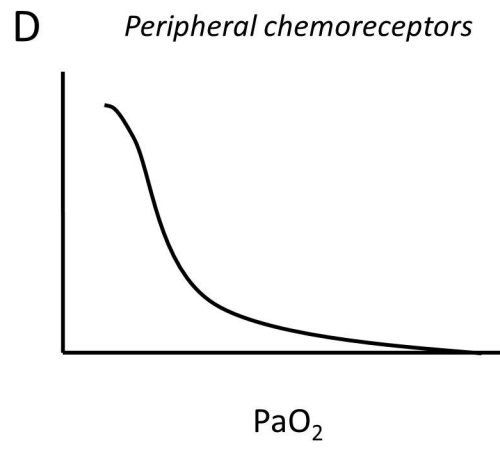
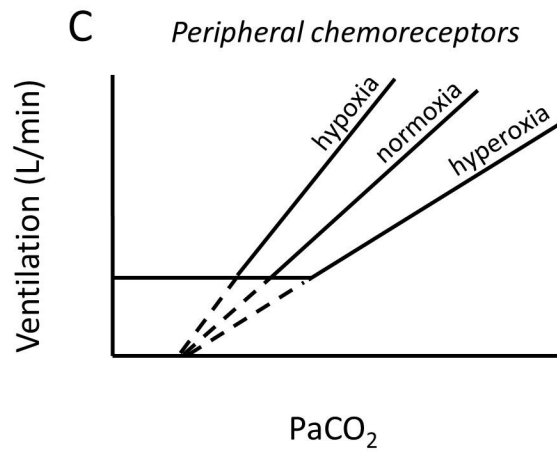
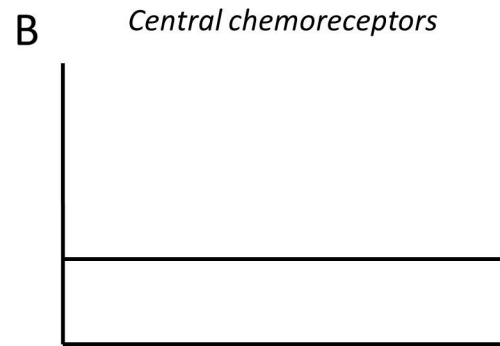
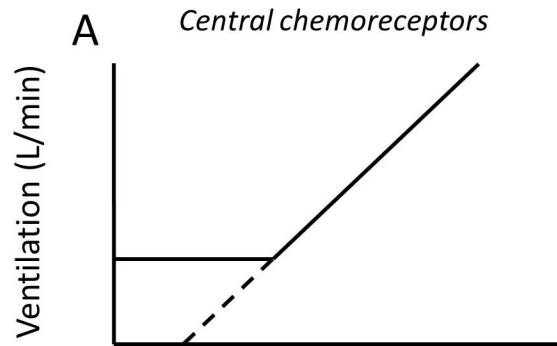

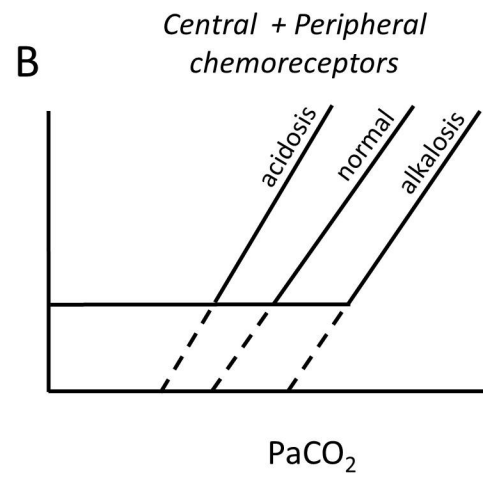
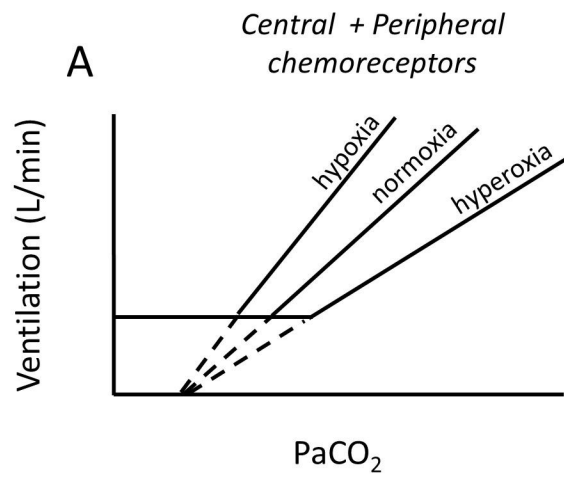

Central chemoreceptors

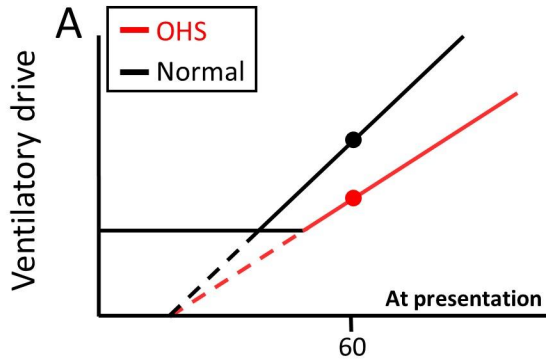

Peripheral chemoreceptors

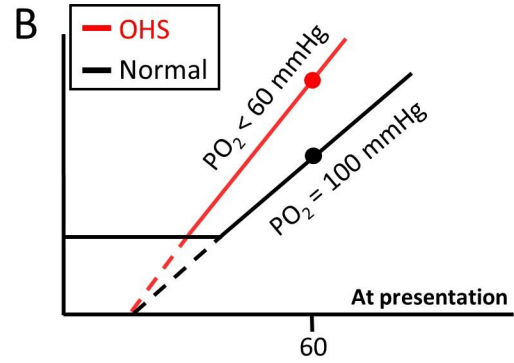

Central + Peripheral chemoreceptors

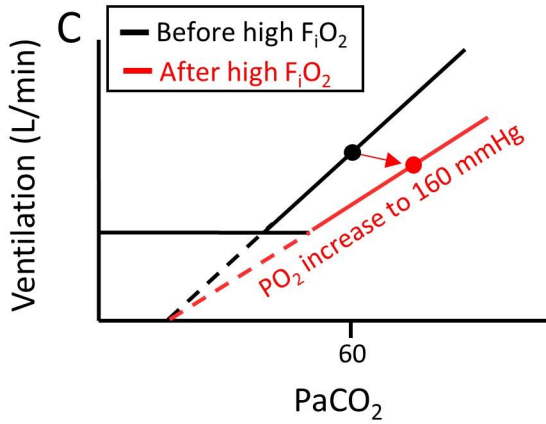

Central + Peripheral chemoreceptors

