



Deposited via The University of Sheffield.

White Rose Research Online URL for this paper:

<https://eprints.whiterose.ac.uk/id/eprint/131884/>

Version: Published Version

Proceedings Paper:

Wirawan, N., Abdullah, N.A., Akbar, M. et al. (2018) Analysis on cracked commuter aircraft wing under dynamic cruise load by means of XFEM. In: Journal of Physics: Conference Series. Modern Practice in Stress and Vibration Analysis (MPSVA) 2018, 02-04 Jul 2018, Cambridge, UK. IOP Publishing. ISSN: 1742-6588.

<https://doi.org/10.1088/1742-6596/1106/1/012014>

Reuse

This article is distributed under the terms of the Creative Commons Attribution (CC BY) licence. This licence allows you to distribute, remix, tweak, and build upon the work, even commercially, as long as you credit the authors for the original work. More information and the full terms of the licence here:

<https://creativecommons.org/licenses/>

Takedown

If you consider content in White Rose Research Online to be in breach of UK law, please notify us by emailing eprints@whiterose.ac.uk including the URL of the record and the reason for the withdrawal request.

PAPER • OPEN ACCESS

Analysis on Cracked Commuter Aircraft Wing Under Dynamic Cruise Load By Means of XFEM

To cite this article: N Wirawan *et al* 2018 *J. Phys.: Conf. Ser.* **1106** 012014

View the [article online](#) for updates and enhancements.



IOP | ebooks™

Bringing you innovative digital publishing with leading voices to create your essential collection of books in STEM research.

Start exploring the collection - download the first chapter of every title for free.

Analysis on Cracked Commuter Aircraft Wing Under Dynamic Cruise Load By Means of XFEM

N Wirawan¹, N A Abdullah^{2,3}, Mahesa Akbar² and J L Curiel-Sosa^{2,4}

¹ Aeronautics Technology Center, National Institute of Aeronautics and Space of Indonesia (LAPAN), Bogor, Indonesia

² Department of Mechanical Engineering, Computer-Aided Aerospace and Mechanical Engineering Research Group (CA²M), The University of Sheffield, The Portobello Centre, Sheffield, S1 4ET, United Kingdom

³ Department of Mechanical Engineering, International Islamic University Malaysia, Malaysia

E-mail: nanda.wirawan@lapan.go.id

E-mail: makbar2@sheffield.ac.uk

Abstract. In this paper, a new investigation of crack propagation on a commuter aircraft wing is discussed. The aircraft is a 19-seater multi-purpose commuter aircraft designed for a mission on the remote area. The dynamic load acting on the wing is assumed as harmonic load considering aerodynamic lift at a particular excitation frequency. A 3D wingbox CAD model is developed for the numerical simulation. Extended finite element (XFEM) is applied to analyse the crack propagation on the aircraft wing. The crack growth simulation is successfully done, and the results are shown in some details. These results provided a novel insight on the computational simulation of cracked wing structure under dynamic flight load.

1. Introduction

In the industrial aircraft design process, the structural damage analysis commonly evaluated through static/quasi-static load analyses [1], and to some extent, the dynamic analysis concerning fatigue-related issues [2–4]. Mathematical and numerical models related to those subjects have as well been developed since decades ago [5; 6]. However, despite this fact, structural damage analysis exerted by the dynamic load under the aeroelastic condition is still received little attention.

Two of the earliest numerical investigations on damaged lifting surface concerning aeroelastic condition were presented in [7; 8]. Both articles presented the studies on a cracked panel made of under supersonic condition. Similar schemes were also applied, finite element method and piston theory were utilised to model the structural and aerodynamic parts, respectively. However, Chen and Lin [7] used isotropic materials, while the latter, Lin et al. [8], used anisotropic materials. The results of both articles concluded that the existence of cracks might decrease the critical flutter speed. Despite this fact, it was found, interestingly, that for anisotropic panels at a particular configuration, the flutter boundary increases with the existence of cracks [8].

⁴ Web address: <http://www.jlcurielsosa.org/>

The results of Lin et al. [8] were supported by the investigations done by Wang et al. [9] and Abdullah et al. [10]. Both observed that cracking could increase the flutter speed for a specific fiber orientation. However, different with Lin et al. [8], both investigations in [9; 10] were done for the subsonic condition. Other investigations on cracked composites lifting structure can be found in [11–14]. Pidaparti [11] observed the panel with microcracks; Kapania and Castel [12] observed cracks on the swept wing; Wang and Inman [13], Georgiou et al. [14] introduced a probabilistic aeroelastic model for the cracked panels via the Polynomial Chaos Expansion (PCE).

However, the investigations in [11–14] were all assumed a static crack condition, without crack growth. To the authors' knowledge, to this date, only Strganac and Kim [15] considered the damage growth on a cracked panel subjected to an aeroelastic load. They utilised Internal State Variable (ISV) as the damage model to quantify the growth of crack density. It was observed, as the crack is grown, the flutter boundary initially dropped. However, up to a certain point, the boundary is almost unaffected by the crack growth due to the damage accumulation getting closer to a full damage evolution [15].

In the present work, an initial effort to observe the crack propagation of lifting structure under the aeroelastic condition is presented. In this effort, firstly, the aerodynamic load is calculated via steady model estimation, The Lifting Line Theory (LLT). Then, the aerodynamic loads are assumed oscillating harmonically within a range of excitation frequencies. Extended finite element method (XFEM) is utilised to model the cracked structure.

In the past decade, along with the growth of more advanced numerical methods, the structural testing has been moving towards virtual experiments [16]. In terms of damage modeling, various high-fidelity approaches, i.e., continuum damage mechanics [17], cohesive elements [18], have been applied to represent cracks. XFEM, first introduced by Belytschko and Black [19], has attracted large attention in the field of numerical damage mechanics due to the ease of modeling the crack propagation with minimum remeshing [20]. Several researchers have shown its robustness as the numerical results could closely represent the experiments for various cases, i.e., delamination [21], multiaxial loading [22], transverse crack and delamination [23; 24].

Therefore, the work presented in this article is aimed, for the first time, to establish the scheme to evaluate the crack propagation on a structure under aerodynamic loads. Within the continuous work of the authors, this scheme is expected, to be extended for a more realistic aeroelastic condition with the coupling of the unsteady aerodynamic loads. In addition, due to the ease of XFEM, it is possible to investigate crack growth on a more complicated and detailed structure, i.e., aircraft wingbox, as presented herein.

2. The Extended Finite Element Method (XFEM)

In this section, a brief introduction to the extended finite element method (XFEM) is presented. For a more detailed overview of XFEM, interested readers are referred to [20; 25].

In general, standard finite element formulation uses the singular element to model the crack tip. Thus, when the crack is growing, the domain around the crack tip should be remeshed to maintain the geometry of the propagating crack. Therefore, for a more complicated structure, the computational cost may increase significantly due to remeshing. XFEM added special enrichment functions into the finite element formulation. Belytschko and Black in [19] first proposed this concept of discontinuous enrichment functions. The enrichment functions used to construct additional displacement fields on the meshed domain. These additional displacement fields represent the discontinuities, i.e., cracks, within an element.

The displacement field of a domain discretised into n -node elements with the addition of the enrichment function can be written as follows [19]:

$$\mathbf{u}^h(x) = \mathbf{u}^{\text{FE}} + \mathbf{u}^{\text{Enr.}} = \sum_{i=1}^n N_i(x) \mathbf{u}_i + \sum_{j=1}^m N_j(x) H(x) \mathbf{a}_j \quad (1)$$

Where \mathbf{u}^{FE} , denotes the displacements of the standard degree of freedoms (DOFs), \mathbf{u}_i , of the n -node elements. The selected nodes around the discontinuity now have extra DOFs as these nodes are enriched. $\mathbf{u}^{\text{Enr.}}$ represents the additional displacement field of the enriched DOFs, \mathbf{a}_j . N is the regular shape functions of the finite element, while H represents the enrichment function, i.e., Heaviside function.

Concerning the displacement field in Eq.(1), the enriched element stiffness matrix is much larger than the standard FE stiffness matrix. It will contain the components associated with the regular DOFs, enriched DOFs and also the coupling components between the regular and enriched DOFs. For example, if the size of the standard FE stiffness matrix is $n \times n$, then the enriched stiffness matrix is $(n+m) \times (n+m)$, where m denotes the number of enriched DOFs.

3. Computational scheme algorithm

In the present computational simulation, the XFEM module in ABAQUS software is used. Periodic load function is applied to model the excitation load on the structure. The workflow to apply the oscillating aerodynamic load on the structure is defined as follows:

- (i) Perform modal analysis to obtain the mode shapes and the related natural frequencies.
- (ii) Evaluate the aerodynamic pressure distribution on the structure for a certain flight condition, i.e., airspeed and density, via the Lifting-Line Theory (LLT).
- (iii) Select a range of excitation frequencies in relation to the mode of interest.
- (iv) Construct the excitation load by
 - (a) applying the aerodynamic pressure as the force amplitude to the elements/nodes,
 - (b) then select the periodic amplitude function, and input one excitation frequency from the previously selected range.

After the excitation load is formed, the XFEM module can be performed in the ABAQUS considering a particular loading time. However, it is important to note, the XFEM module in ABAQUS may or may not require a crack initiation as an input. In the case crack initiation is present; usually, it is applied to the area with large stress concentration to observe the criticality of the structure.

4. Numerical investigation on cracked wingbox structure

In the present work, a commuter aircraft wingbox in [26] is adopted. The layout of the wing is depicted in Figure 1. The mass configuration for maximum take-off weight (MTOW) at maximum fuel is used.

The wingbox is discretised using several types of elements. The skins, ribs and spars are modeled by the shell and solid elements. The stringers are represented by the beam elements. The engine, the control surfaces at the trailing edge and the fuel masses are modeled by lumped mass elements. The rigid bar elements are used to connect the lumped masses of engine and control surfaces to their respective hinge points. The wing components are all made of aluminium 6061-T6 with Young's modulus 68.9 GPa, density 2710 kg/m³ and maximum principal stress of 290 MPa. Figure 2 shows the corresponding elements type of the structural components.

Validation of the wingbox finite element model of the wingbox is done by comparison with the numerical investigation done by the industry that developed the aircraft. The stick model, a simplification of the structure using only beam elements and lumped masses, is used in their

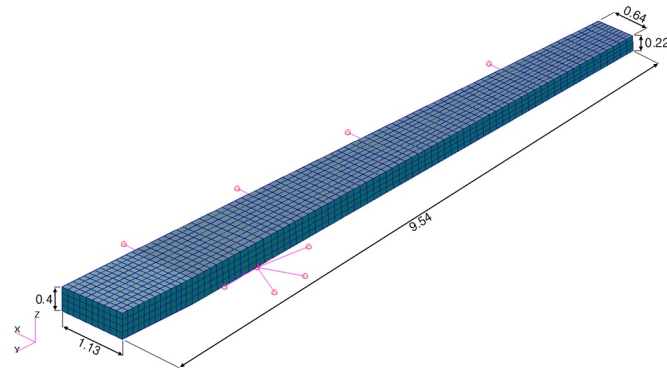

Figure 1: Wingbox layout (unit length in m)

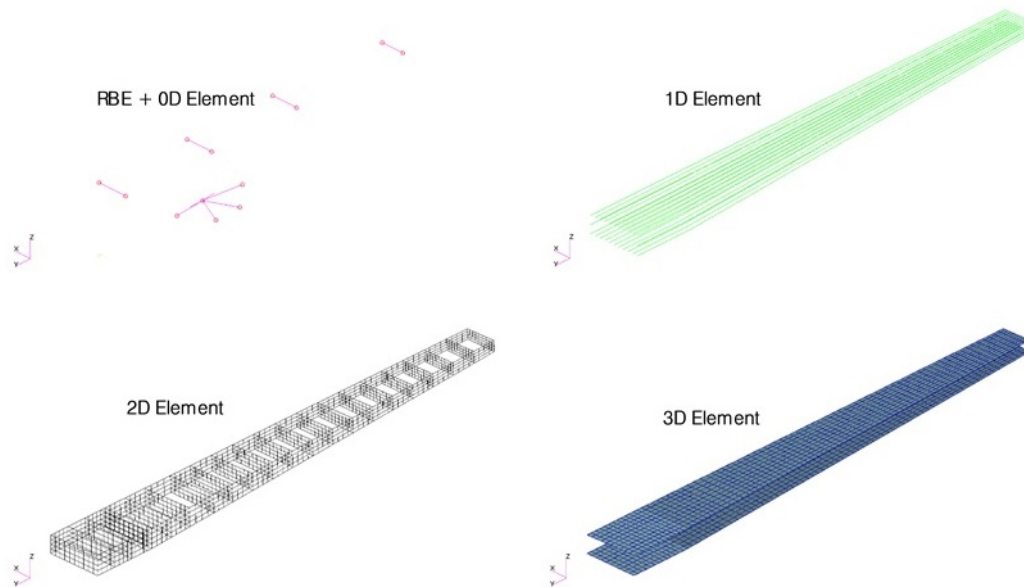

Figure 2: Wingbox components and their respective elements

Table 1: Natural Frequency Comparison of The Present Detailed Model with The Stick Model

Mode	Natural frequency (Hz)			Remarks
	Present	Stick Model [27]	Δ	
1	2.59	2.47	4.6 %	1st Vertical Bending
2	5.58	4.58	17.9 %	1st In-plane Bending
3	8.74	8.28	5.6 %	2nd Vertical Bending
4	12.76	11.56	9.4 %	1st Torsion

investigation. Their results were presented in [27]. The present model is in good comparison with their results as depicted in Table 1.

The cruise flight condition is observed. The aerodynamic lift distribution is depicted in Figure 3a. As aircraft structure commonly have a low-frequency vibration, the range of excitation frequencies around the 1st vertical bending mode is applied. Prior investigating the crack, a dynamic response analysis in the frequency domain is performed to the wingbox without the

crack. The frequency response function (FRF) of the tip displacement is shown in Figure 3b.

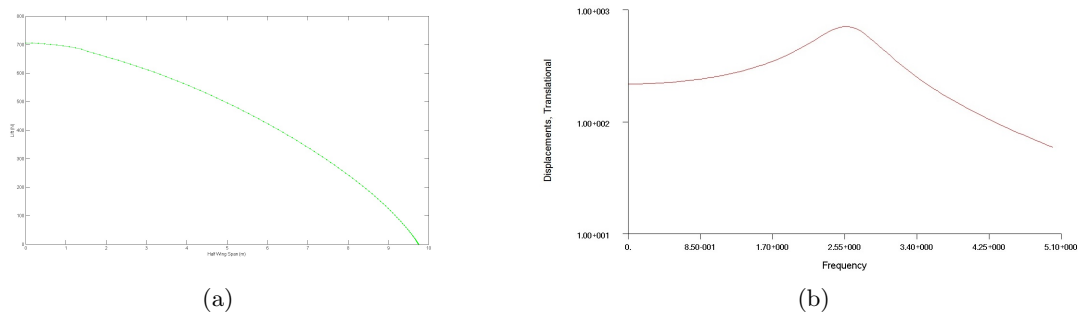

Figure 3: (a) Aerodynamic lift distribution along the span (b) Tip displacement FRF due to aerodynamic load

It can be seen from Figure 3b, the response peak is when the excitation frequency equal to the 1st vertical bending natural frequency, or so-called resonance point. The critical aspect here is that until around 1.7 Hz, the response insignificantly changes from the static condition, around 220 mm. However, afterwards, the response increased significantly until around 700 mm at the resonance frequency. Considering that this peak response is more than thrice of the static condition, it is very likely that the structure will completely be destroyed at this stage. The load factor of civil aircraft itself commonly around 1.5-2.5. Hence, to have a reasonable investigation, the crack propagation investigation is limited to the maximum displacement around twice the static condition, at around 2 Hz.

In the present case, a crack initiation is given in the bottom skin near the root, as the largest stress concentration is within this area. Utilising the XFEM module, it is found that until around 1.7 Hz excitation, as expected, the crack is not propagating due to the low-stress level. However, above 1.7 Hz, the crack starts to propagate. When 2 Hz excitation is applied, the crack propagates the most. Figure 4 shows the crack is still not propagating as the displacement is still around 270 mm. However, at the 1st oscillation cycle when it reaches the amplitude, the crack starts to propagate from the lowest layer of the bottom skin as displayed in Figure 5. At the 2nd cycle, the crack propagated longer and grown to the highest layer of the bottom skin before it stopped. The final condition of the crack is shown in Figure 6.

5. Conclusion

A novel scheme to evaluate crack propagation on the wing structure exerted by oscillating aerodynamic load has been developed. The results presented in this paper has shown the ability of the scheme to evaluate the crack propagation of a wingbox structure. Future work will aim to include a more realistic aeroelastic condition with unsteady aerodynamic loads coupling.

Acknowledgments

The authors wishing to acknowledge the support Indonesia national institutions: LAPAN, IAE and BPPT. We also grateful for the funding provided by Ministry of Higher Education Malaysia (MOHE) and International Islamic University Malaysia (IIUM).

References

- [1] Bristow J W and Irving P 2007 *Eng. Fail. Anal.* **14** 459 – 470
- [2] Schijve J 1994 *Int. J. Fatigue* **16** 21 – 32

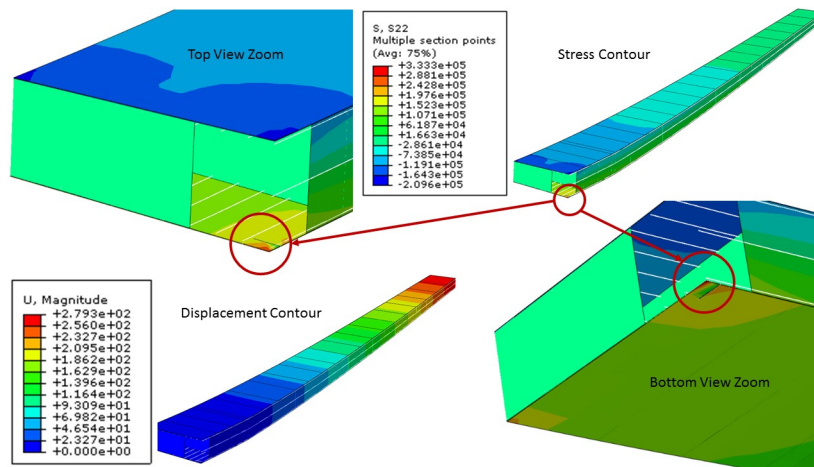

Figure 4: 2 Hz excitation: Stress & displacement contours when the crack is still not growing

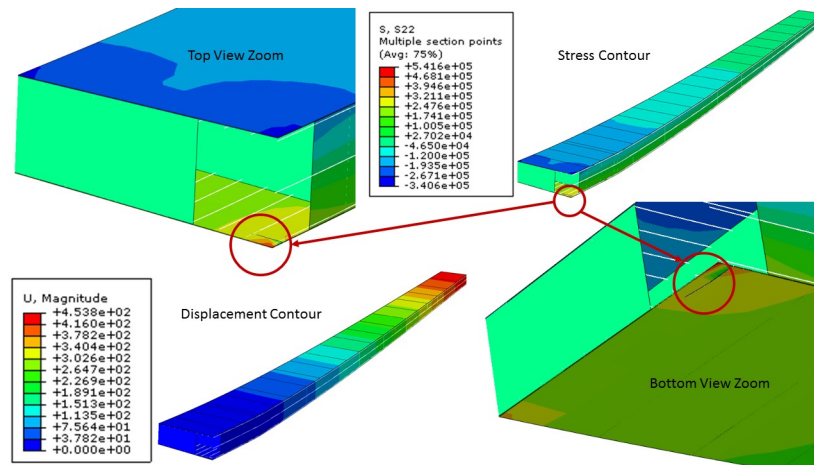

Figure 5: 2 Hz excitation: Stress & displacement contours when the crack is start propagating

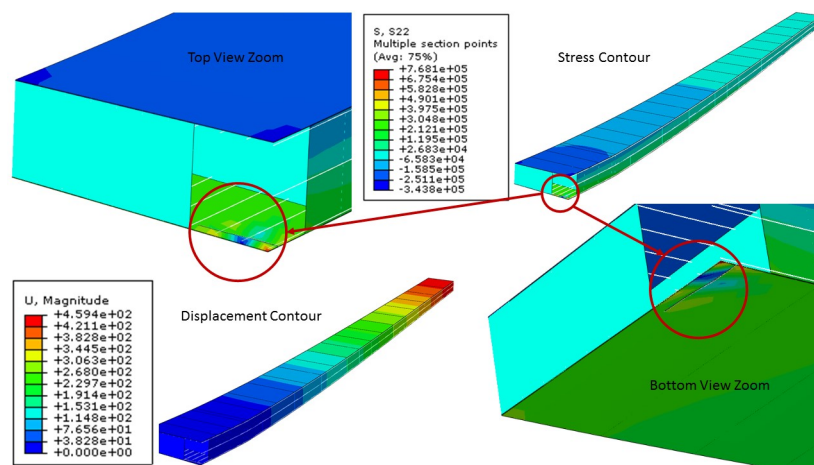

Figure 6: 2 Hz excitation: Stress & displacement contours when the crack is stop propagating

- [3] Iyyer N, Sarkar S, Merrill R and Phan N 2007 *Int. J. Fatigue* **29** 1584 – 1607
- [4] Schijve J 2009 *Int. J. Fatigue* **31** 998 – 1011
- [5] Newman Jr J C 1992 *NASA STI/Recon Technical Report N* **92**
- [6] Grbovic A and Rasuo B 2012 *Eng. Fail. Anal.* **26** 50 – 64
- [7] Chen W H and Lin H C 1985 *AIAA J.* **23** 795 – 801
- [8] Lin K J, Lu P J and Tarn J Q 1991 *J. Aircraft* **28** 899 – 907
- [9] Wang K, Inman D J and Farrar C R 2005 *Struct. Health Monit.* **4** 377–392
- [10] Abdullah N A, Curiel-Sosa J L and Akbar M 2018 *Compos. Struct.*
- [11] Pidaparti R 1997 *Compos. Struct.* **38** 477 – 481
- [12] Kapania R K and Castel F 1990 *AIAA J.* **28** 329 – 337
- [13] Wang K and Inman D J 2007 *AIAA J.* **45** 542 – 551
- [14] Georgiou G, Manan A and Cooper J 2012 *Mech. Syst. Signal Pr.* **32** 32 – 43
- [15] Strganac T W and Kim Y I 1996 *J. Aircraft* **33** 68 – 73
- [16] Pulungan D, Lubineau G, Yudhanto A, Yaldiz R and Schijve W 2017 *Int. J. Solids Struct.* **117** 177 – 190
- [17] Pulungan D, Yudhanto A, Goutham Kumar S, Lubineau G, Yaldiz R and Schijve W 2018 *Polym. Test.* **68** 433–445
- [18] Hernandez E, Alfano M, Pulungan D and Lubineau G 2017 *Sci. Rep.* **7** 16344
- [19] Belytschko T and Black T 1999 *Int. J. Numer. Meth. Eng.* **45** 601 – 620
- [20] Mohammadi S 2008 *Extended Finite Element Method for Fracture Analysis of Structures* (Blackwell Publishing Ltd.)
- [21] Curiel-Sosa J L and Karapurath N 2012 *Compos. Sci. Technol.* **72** 788 – 791
- [22] Moreno M S, Curiel-Sosa J L, Navarro-Zafra J, Vicente J M and Cela J L 2015 *Compos. Struct.* **119** 264 – 271
- [23] Abdullah N A, Curiel-Sosa J L, Taylor Z A, Tafazzolimoghaddam B, Vicente J M and Zhang C 2017 *Compos. Struct.* **173** 78 – 85
- [24] Curiel-Sosa J, Tafazzolimoghaddam B and Zhang C 2018 *Compos. Struct.* **189** 641 – 647
- [25] Belytschko T, Liu W, Moran B and Elkhodary K 2014 *Nonlinear Finite Elements for Continua and Structures* (Wiley)
- [26] Syamsuar S, Sampurno B, Mahasti K M, Pratama M B S, Sasongko T W, Kartika N, Suksmono A, Saputro M I A and Eskayudha D B 2018 *J. Phys. Conf. Ser.* **1005** 012040
- [27] Abdurohman K, Bayu Sakti R M and Wismoyo P 2015 *International Seminar on Aerospace Science and Technology, Bali, Indonesia*