



UNIVERSITY OF LEEDS

This is a repository copy of *Heat transfer and fluid flow over microscale backward and forward facing step: A review*.

White Rose Research Online URL for this paper:  
<http://eprints.whiterose.ac.uk/125295/>

Version: Accepted Version

---

**Article:**

Kherbeet, A, Reza Safaei, M, Mohammed, HA et al. (4 more authors) (2016) Heat transfer and fluid flow over microscale backward and forward facing step: A review. *International Communications in Heat and Mass Transfer*, 76. pp. 237-244. ISSN 0735-1933

<https://doi.org/10.1016/j.icheatmasstransfer.2016.05.022>

---

(c) 2016, Elsevier Ltd. This manuscript version is made available under the CC BY-NC-ND 4.0 license <https://creativecommons.org/licenses/by-nc-nd/4.0/>

**Reuse**

This article is distributed under the terms of the Creative Commons Attribution-NonCommercial-NoDerivs (CC BY-NC-ND) licence. This licence only allows you to download this work and share it with others as long as you credit the authors, but you can't change the article in any way or use it commercially. More information and the full terms of the licence here: <https://creativecommons.org/licenses/>

**Takedown**

If you consider content in White Rose Research Online to be in breach of UK law, please notify us by emailing [eprints@whiterose.ac.uk](mailto:eprints@whiterose.ac.uk) including the URL of the record and the reason for the withdrawal request.



[eprints@whiterose.ac.uk](mailto:eprints@whiterose.ac.uk)  
<https://eprints.whiterose.ac.uk/>

# Heat Transfer and Fluid Flow over Microscale Backward and Forward Facing Step:

## A review

A. Sh. Kherbeet<sup>1, a</sup>, Mohammad Reza Safaei<sup>b</sup>, H. A. Mohammed<sup>f</sup>, B. H. Salman<sup>d</sup>, Hamdi E. Ahmed<sup>e</sup>,  
Omer A. Alawi<sup>c</sup>, M. T. Al-asadi<sup>c</sup>

<sup>a</sup> Department of Mechanical Engineering, KBU International College, 47800 Petaling Jaya, Selangor, Malaysia

<sup>b</sup> Young Researchers and Elite Club, Mashhad Branch, Islamic Azad University, Mashhad, Iran

<sup>c</sup> Department of Thermofluids, Faculty of Mechanical Engineering, Universiti Teknologi Malaysia, 81310 UTM Skudai, Johor Bahru, Malaysia

<sup>d</sup> Department of Mechanical Engineering, University of Nevada, Las Vegas, 89154 NV, USA

<sup>e</sup> Department of Mechanical Engineering, University of Anbar, Ramadi 31001, Iraq

<sup>f</sup> Department of Refrigeration and Air Conditioning Engineering, Technical College of Engineering, Duhok Polytechnic University (DPU), 61 Zakho Road- 1006 Mazi Qr, Duhok-Kurdistan Region- Iraq

## Abstract

Research on convective heat transfer in the microscale backward-facing step (MBFS) and microscale forward-facing step (MFFS) has been extensively conducted in the past decade. This review summarizes numerous researches on the three topics; the first section focuses on studying the effect of the geometry on the fluid flow and heat transfer behavior. The second and the third section concentrates on effect the inclination angle and the flow regime on the fluid flow and heat transfer enhancement. The purpose of this article is to get a clear view and detailed summary of the influence of several parameters such as the geometrical specifications, type of fluids and boundary conditions. The enhancement in the Nusselt number is the main target of such research where correlation equations were developed in numerical and experimental studies are reported.

---

<sup>1</sup> Corresponding author: Tel.: +6 07 55 34716; fax: +6 07 55 66159.

Email address: [akeel.fa7@gmail.com](mailto:akeel.fa7@gmail.com) (A.Sh. Kherbeet),

contents

- 1 Introduction
  - 2 Flow geometry
    - 2.1 Forward facing-step.
    - 2.2 Backward facing-step.
  - 3 Inclination angle
  - 4 Flow regime
    - 4.1 Natural convection.
    - 4.2 Mixed convection.
    - 4.3 Forced convection.
  - 5 Conclusion
- References

## **1. Introduction**

The flow separation phenomenon and subsequent reattachment due to a sudden expansion or compression in the flow passages, such as backward-facing and forward-facing steps, play a substantial role in the design of a wide variety of engineering applications where cooling or heating is required. The applications of heat transfer appear in such, combustion chambers, environmental control systems, cooling systems for electronic equipment, chimerical process and energy systems equipment, high performance heat exchangers, cooling passages in turbine blades, and flow in valves. In many of engineering applications, the separation of flow is undesirable due to unwanted pressure drops and energy losses which require additional pumping power to overcome them. However, in another application, the flow separation and the reattachment region may be encouraged to enhanced heat and mass transfer rates. Because of this fact, the laminar and turbulent flow over backward-facing and forward-facing step geometries in mixed, natural, and forced convection have been investigated rather extensively, both experimentally and numerically. However, case studies such as ribs geometry, injection flow, and onset inlet flow are not considered in the present review.

A vast numerical and experimental and studies focused on flow and heat transfer behavior of convective flow over backward and forward facing-step geometries have been reported. These vast information and results have dealt with different parameters, conditions, instrumentation, and geometry dimensions, which indeed to undefined solid base for comparison purposes to demonstrate more accurate methodology for solving the case studies.

The dispersion of these results hauls the attention of many researchers to unify the information to general criteria. Furthermore, the Aerospace Heat Transfer Committee (K-12) of the Heat Transfer Division of the ASME held a technical session at the 1993 ASME Winter Annual Meeting for a benchmark heat transfer problem [1 and 2]. In addition, due to the importance of separation and reattachment phenomenon, Abu-Mulaweh, [3] reviewed the results of the flow and heat transfer of single-phase laminar mixed convection flow over different orientations of both backward and forward facing steps for several previous works. While, [4] reviewed the results of effect many parameters on the flow characteristics and heat transfer of single-phase fluid flow over backward facing step.

The objective of this chapter is to present a comprehensive review of the flow and heat transfer results of recent studies of single-phase natural, forced, and mixed convection flow over backward-facing and forward-facing steps. The second purpose is summarized and presented the results of the effects of many parameters on the fluid flow and heat transfer characteristics such as, local heat transfer rate and reattachment lengths, the effects of buoyancy force (assisting and opposing), step height, inclination angle, Prandtl number, Reynolds number, and temperature difference between the heated wall and the free stream on these parameters. The third purpose of this review is to understand the function and characteristics of nanofluids, to expect their effects and heat transfer enhancement in such geometries. The review starts with an extensive review on the flow and heat transfer over backward and forward facing step channels. After that, a comprehensive review for nanofluids and it is characteristics were described. At the end, the review concentrates on the flow and heat transfer over a backward and forward facing step using nanofluids.

## 2. Flow Geometry

The scope of this review is to summarize the heat transfer convection flow over backward and forward facing-steps. Figure 1 presents the configuration of backward and forward facing-step. Both uniform wall temperature (UWT) and uniform heat flux (UHF) were considered.

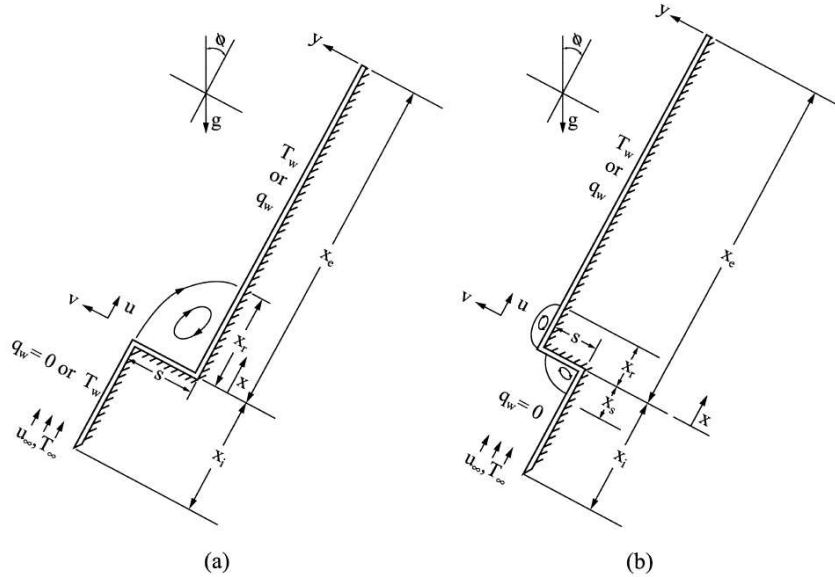

**Figure 1.** Configuration of the step geometries: (a) backward-facing step (b) forward-facing step [3].

### 2.1 Backward Facing-Step

In the last decades, the convective heat transfer and fluid flow over a backward facing step has been widely investigated, both numerically and experimentally. In the late of 1950s, the first attempt was presented for studying the separation and reattachment flow over a backward-facing step. The revolution of technology development and the improvement of the numerical codes lead to increase the number of new research in such problem and facilitate the complex study of three-dimensional flow in the separation and reattachment zone. The mixed, forced, and natural flow over backward facing-step were investigated for different geometrical parameters, boundary conditions and fluids properties.

The numerical simulation of [5] on mixed convective flow over three dimensional horizontal backward facing step heated from below. They found that when the Richardson number ( $Ri$ )

increased the recirculation zone was shortened due to the presence of strong buoyancy forces and higher velocity components in vicinity of heated wall. The average Nusselt number distribution at the entrance of backward-facing step channel had a high value and monotonically decreased. The location of maximum spanwise average Nusselt number shifted upstream with increasing Ri number. As Ri number increased, the vertical size of recirculation zone was reduced.

Abu-Nada [6] examined the flow over a backward facing step with various expansion ratios. He showed that as Re number increased, the value of total Ns (entropy generation) increased. For lower Re numbers, the value of Ns decreased as the expansion ratio increased. However, for higher values of Re number, the Ns decreased as expansion ratio increased. The maximum value of Ns occurred at the step and it decreased downstream of the step until it reached a minimum value towards the channel outlet. The maximum value of Ns occurred inside the recirculation zone, while the minimum value of Ns took place at the step.

Abu-Nada [7] presented a numerical investigation of heat transfer over a backward facing step (BFS), using nanofluids (water base fluid) with different concentrations and types of nanoparticles. The results showed that, at the top wall, there was an enhancement in Nusselt number by increasing the particles volume fraction. Nusselt number increased by increasing the volume fraction of the nanoparticles. The maximum value of Nusselt number on the bottom wall, coincided with the point of reattachment. As a continuous work, Abu-Nada [8] explored the flow over a backward facing step subjected to bleeding by using suction/blowing. He showed that the suction increased the value of Ns while blowing reduced the value of Ns due to increased temperature and velocity gradients for the case of suction compared to that of blowing. The enhancement of heat transfer at the bottom wall was accompanied with an increase in the value of Ns. The maximum value of Ns was at the leading edge of the top wall due to the high shear rates encountered due to the boundary layer development. The coefficient of friction is negative inside the recirculation bubble due to the back flow and it was zero at the point of reattachment due to the vanished velocity gradients. Continuously, Abu-Nada et al. [9] illustrated that for the blowing case and  $Re = 800$ , the reattachment length increased until it reached to its maximum value then decreased due to high values of bleed coefficient and blowing forced the flow to detach. The blowing reduced velocity gradients and accordingly reduced friction coefficient. The suction increased the friction

coefficient before the reattachment point due to streamlines attraction. He concluded that Nusselt number increased by suction and decreased by blowing.

Chen et al. [10] studied the effect of step height on turbulent convection flow adjacent to a backward-facing step. It was observed that the reattachment length increased with increasing the step height. Higher step heights enlarged the size of the primary recirculation region adjacent to the backward-facing step in both length and height. The magnitude of negative velocity component and the positive velocity component decreased with the increase of step height. Besides, the maximum temperature difference became greater as the step height increase. The values of skin friction coefficient and shear stress were minimum at the reattachment point, and inside the recirculation region the magnitude of peak friction coefficient did not significantly change with step height. Downstream of the reattachment point, the skin friction coefficient approached the fully developed channel flow and its magnitude became smaller with the increasing of step height.

Iwai et al. [11] investigated the effect of the duct aspect ratio on flows over a backward-facing step at low Reynolds numbers. The result revealed that the highest value of Nusselt number along the centerline of the bottom wall increased and its location moved upstream as the aspect ratio increased. The skin friction coefficient also increased with increasing the aspect ratio. The maximum Nusselt number appeared near to the both side walls not on the centerline of the bottom wall in all the cases. By increasing Reynolds number, the maximum Nusselt number became larger and its streamwise location shifted downstream.

Hsieh et al. [12] tested the 3D flow in microscal backward-facing step (MBFS). They reported that the magnitude of velocity decreased as the cross-section aspect ratio decreased due to the additional friction from the side walls. The results showed also that the shear stress along the wall behind the step was proportional to the slip velocity. The results as the cross-section aspect ratio decreased, the heating effect caused by the side walls increased and the local temperature raised up.

Abu-Mulaweh et al. [13] illustrated that the lower free stream velocity produced higher Nu number in the recirculation region due to the change in the size of the recirculation region. The reattachment length, and hence the size of the recirculation region, increased as the free stream velocity or the step height increase. While the results for inclined backward-facing step

demonstrated that the local Nusselt number decreased as the inclination angle from the vertical increased due to a decrease in the temperature gradient at the heated wall. An increase in the inclination angle led to increase in the location of the maximum Nusselt number and the reattachment length due to a decrease in the stream wise buoyancy force. Continuously, the experimental results of Abu-Mulaweh et al. [14] focused on the effect of the backward-facing step heights on turbulent mixed convection flow along a vertical flat plate. It was observed that the length of the recirculation region extended with increasing step height. The magnitude of the negative mean transverse velocity component increased with increasing step height. However, the introduction of the step height enhanced the turbulence intensity, which caused the flow to become turbulent downstream of the step. The magnitudes of the intensities of both velocity, temperature fluctuations and the measured local Nusselt number downstream of the step increased with increasing the step height.

Kherbeet et al. [15] explored the effect of step height of MBFS on the flow and heat transfer characteristics using EG-SiO<sub>2</sub> nanofluid. The results showed that, there was complex three-dimensional flow developed downstream from the step with swirling and reverse flow regions adjacent to the side wall. The flow in the separating region was impinged on the stepped wall and it was responsible for developing maximum values in Nusselt number and a minimum in the reattachment length. The increasing of the step height caused an increase in the reattachment length, thus Nusselt number, and the size of the sidewall reverse flow region. It was found that the increase in the step height led to increase the skin friction coefficient and decrease the pressure drop.

## **2.2 Forward Facing-Step**

For a flow over forward-facing step, there is one or two recirculation regions may have developed adjacent to the step, which is depending on the magnitude of the flow Reynolds number and the thickness of the momentum boundary layer at the step. A separation region can develop downstream of the step and another can develop upstream of the step. These separated flow regions make this geometry more complicated to study than the backward-facing step in which only one separated flow region occurs behind the step. Owing to this fact, there was very limited number of researchers has examined the flow over a forward facing step in contrast to the backward-facing step geometry.



Abu-Mulaweh [16] presented measurements of heat transfer and fluid flow of turbulent mixed convection air flow over an isothermal vertical forward-facing step (FFS). They reported that the introduction of the FFS significantly affected the flow characteristics in the recirculation region downstream of the FFS. The magnitudes of the turbulent intensities of both velocities (streamwise and transverse) and temperature fluctuations increase as the FFS height increases. The local Nusselt number increased with increasing the distance from the step, reaching a maximum value in the vicinity of the reattachment region. The Nusselt number magnitude decreased as the distance continues to increase in the streamwise direction. The local Nusselt number downstream of the FFS increased with increasing step height. The increasing the FFS height greatly enhanced the turbulence intensity of both velocity and temperature fluctuations. The location of the maximum local Nusselt number moved away from the FFS as the step height increases.

Stüer et al. [17] explored the separation ahead of a FFS under laminar flow conditions using the hydrogen bubble technique to visualize and PTV for evaluating the 3D velocity field in an Eulerian representation in the vicinity of the step. The results demonstrated that the side-walls had no effect on the unsteady behavior. At the stagnation point, the pressure field accelerated the fluid sidewise until it was released over the step. The new vorticity generated on the step was much larger than the transported vorticity. The longitudinal vortices created were rather weak compared with the newly created vorticity at the wall above the step and as this started to dominate, the longitudinal vortices disappeared, whereupon the vorticity became largely aligned with the span-wise direction again.

Gandjalikhan et al. [18] examined numerically the effect of step length and its inclination angle on turbulent fluid flow and heat transfer distributions over a single FFS. They displayed that Nu number increased with increasing Re number for the whole range of inclined angle. The variation of Nu number for each of step length was similar to those at 50° and 20°. The local Nusselt number after the step surface first decreased sharply along a very short distance, then it increased to a maximum value in the reattached point and finally it decreased along the flow direction up to the outlet section. Finally, Nusselt number increased with increasing the step length in all parts of the bottom wall.

Sherry et al. [19] investigated experimentally the recirculation zone formed downstream of a FFS immersed in a turbulent boundary layer. The results showed that the recirculation zone downstream of a FFS existed in a quasi-steady state due to the higher deflection of the incoming flow. The recirculating flow within the separated region was ejected when the region can no longer sustain the amount of entrained fluid. The results also showed that the flow over the FFS became increasingly three dimensional with decreased in the aspect ratio. However, the higher free stream velocity above the free shear layer counteracted the increased flow deflection and limit shear layer expansion. The reattachment length affected significantly by an increase in Re number due to the velocity gradient in the boundary layer. The maximum power available to a wind turbine through a given area increased with the cube of the mean wind speed.

Taher and Adam et al. [20] performed a set of simulations examining the turbulent flow over a triple FFS configuration using standard k- $\epsilon$  turbulence model. They outlined that an increase in separation with the increase of both Reynolds number and the step height was observed. The higher step heights ratios produced higher turbulent kinetic energy and the same was registered for Reynolds number. Low levels of turbulence dissipation rate were monitored which corresponds to the low values of turbulent kinetic energy. Moreover, the turbulence dissipation rate ( $\epsilon$ ) exhibited an increase with increasing Reynolds number. They revealed that the pressure coefficient decreased significantly with increasing Reynolds number as implied by the inverse proportionality between the pressure coefficient and the square of the velocity magnitude. The maximum vorticity over each step changed linearly with Reynolds number increase.

Hattori and Nagano [21] presented investigation of the detailed turbulent structure of a boundary layer over a FFS. They showed that in the case of  $Re = 3000$ , there was smallest separation region in front of the step observed. For  $Re = 1900$  and for two values of step height, there was tiny second recirculation region on the step near the corner which caused the decrease in friction coefficient. When Reynolds number increased, the vortex structure clearly became fine, and the step caused production of a finer vortex than that in front of the step. As the step height increased, the vortex structure was promoted more than in the case of  $Re = 900$ . The effect of the step obviously influenced the redevelopment of the boundary layer in the downstream region.

### 3. Inclination angle

Hong et al. [22] studied numerically the effect of inclination angle and Prandtl number on laminar mixed convection flow in an inclined duct with backward-facing step for both buoyancy assisting and buoyancy opposing flow conditions. It was revealed that the inclination angle variation influenced the magnitude of the buoyancy parameter in both x- and y-directions. As the inclination angle increased from  $0^\circ$  to  $180^\circ$ , the buoyancy force in the x-direction decreased reaching its minimum value at  $\gamma = 180^\circ$ . The reattachment length increased with increasing inclination angle for  $0^\circ \leq \gamma < 180^\circ$  and decreased with increasing inclination angle for  $180^\circ \leq \gamma < 360^\circ$ . This made Nusselt number to increase and then decreased, respectively.

Iwai et al. [23] presented 3D numerical simulation of the effect of two inclination angles; pitch angle (the angle between the stream-wise direction and vertical upward direction) and rolling angle (The angle between normal direction and vertical direction) of mixed convective flow over backward-facing step in rectangular duct. The results illustrated that the positions of secondary recirculation, peak Nusselt number and reattachment point on the center line of the heated wall shifted with pitch angle. The maximum Nusselt number appeared at the most upstream position in the case of pitch angle of  $0^\circ$  and rolling angle of  $90^\circ$  and takes the highest value. However, rolling angle has little effect on the spanwise position of maximum Nusselt number.

Lin et al. [24] investigated the effects of inclination angle on the mixed convection heat transfer with backward-facing step numerically. They reported that an increasing of inclination angle caused a decrease in the streamwise buoyancy force and an increase in the reattachment length. The temperature of fluid increased with increasing the inclination angle due to the change in the velocity distribution and the required energy balance. By increasing the angle, the shear stress at the heated wall decreased, where it increased at the unheated wall, with increasing observed in the reattachment length and the recirculation region behind the step.

## **4. Flow regime**

### **4.1 Natural convection**

In this field, there was just one paper presented by Abu-Mulaweh [25] in which the effects of macroscale backward-facing and forward-facing steps on turbulent natural convection along a vertical heated flat plate was experimentally investigated. The experimental investigation was carried out in an existing low turbulence, open circuit tunnel that was oriented vertically. Both of the steps geometries consist of backward-facing step or forward-facing step. The measurements revealed that the effect of the steps and the thermal conditions of the wall on the mainstream diminished at distances beyond ten times of step height in the transverse direction away from the heated wall. These observations established that a reverse flow existed in the upper part of the tunnel in a small and very narrow region adjacent to the unheated wall. In addition, when the backward-facing step was introduced it was found that only one recirculation region developed and located behind the step. It was thicker and longer than the recirculating region associated with the forward-facing step. The effect of the backward-facing/forward-facing step decrease as the streamwise distance increases downstream from the step. Nusselt number increased with increasing distance from the step, reaching a maximum value in the vicinity of reattachment region of almost twice that of flat plate for case of backward-facing step. The local Nusselt number for the case of backward facing step was much less than that of forward-facing step.

### **4.2 Mixed convection**

In many flows of practical interest, the phenomenon of flow separation, due to a sudden expansion in geometry, and the subsequent reattachment, is a common occurrence. The existence of a flow separation and a recirculation region has a substantial effect on the performance of thermal devices, such as in cooling passages of turbine blades, electronic cooling equipment, combustion chambers, and many other heat exchanger surfaces that appear in engineering designs. So that, a comprehensive research on the fluid flow with mixed convection over backward facing-step were published.

Hung and Kuei [26] presented a numerical study of transient mixed convection of a backward-facing step flow. The results showed that the separation occurs at the lower concave corner of the step in the early development of flow. The separation bubble grows with increasing the time until the quasisteady state was reached. There exists a small secondary recirculation region at the lower corner of the step, and the separation point was not right at the corner tip but at some lower point of the upper corner. The results revealed that the periodically heated wall has no effect on the flow field. In this study, and the oscillatory wall temperature did not affect the distribution of isotherms for high Prandtl number fluid.

Khanafer et al. [27] investigated numerically the mixed convection laminar pulsatile flow and heat transfer past a back-ward-facing step. They demonstrated that as Re number increased (decrease Ri number), the impact of forced convection was observed and the recirculation zone along the heated surface increased. The average Nusselt number and the length of recirculation zone were decreased with an increase in Ri number. Moreover, as Re number increased, the local variation of Nusselt number increased within the recirculation region as well as the region right after the recirculation bubble. The results also illustrated that when buoyancy force increases, the velocity gradient near the heated wall and consequently increased the wall skin friction coefficient. As Ri number increased, the intensity of convection intensified within the cavity due to the increase in buoyancy effect. Moreover, the average Nusselt number increased along the heated wall. In contrast, when Re number increased, the thermal boundary layer along the heated wall decreased and therefore the heat transfer increased. Moreover, the average wall skin friction coefficient decreased with an increase in Re number due to the decreased in the buoyancy force with an increase in Re number.

Kung et al. [28] studied the transient mixed convection of a second-grade viscoelastic fluid past an inclined backward facing step to study the effects of Reynolds number, the elastic effect, and the inclined angle of the flow channel on the reattachment length. They stated that the second recirculation zone could retain even at the steady state with lower Re number because of the elastic effect which can sustain the pull of the main stream and the viscous dissipating effect. In the main recirculation zone, the vorticity was positive and it was negative downstream the plate. The buoyancy of the x-direction influenced the reattachment length significantly due to the inclined backward facing step. The local Nu number increased rapidly from the concavity of the step,

reached its maximum value near the reattachment point, then, slightly decreased and maintains constant value up to the exit. It is also reported that increasing the Re number, the reattachment length increased.

Lin et al. [24] studied numerically the effect of buoyancy flow of laminar mixed convection heat transfer in vertical backward-facing step channel. They have reported that increasing of wall temperature (buoyancy force) led to decrease the reattachment length and increase the size of the secondary inner recirculation region that developed at the corner between the heated wall and the step. An increase in the buoyancy force led to increase the friction coefficient. Nusselt number was increased as the wall temperature increased and the peak Nusselt number distribution continued even after the disappearance of the reattachment point from the heated wall.

Abu-Mulaweh et al. [29] presented measurements and predictions of velocity and temperature distributions in buoyancy-assisting, laminar, mixed convection boundary layer flow over a vertical backward-facing step. It was evident that the buoyancy force significantly affected the flow characteristics in the recirculation region. As the wall heat flux increased, the size of the recirculation region and hence the reattachment length was decreased. The local Nusselt number at the heated wall increased with increasing distance from the step, to a maximum value at some distance downstream of the reattachment point, and then decreased slowly as the distance continues in the increase in the streamwise direction. In addition, as the buoyancy force increased (with increasing wall heat flux), the local Nusselt number increased.

Abu-Mulaweh et al. [30] conducted that the buoyancy-induced flow adjacent to the heated wall was in a direction opposite to the main forced flow. The main flow and the buoyancy-induced flow interact with each other. The length of the recirculation region for laminar regime downstream of the backward-facing step increased rapidly as the buoyancy level increased. In contrast, the heat transfer decreased as the buoyancy force increased. For a fixed wall temperature, as the free-stream velocity increased, the temperature gradient at the wall increased.

The 2D numerical study of Kherbeet et al. [31] concentrated on laminar mixed convection flow over a horizontal microscale backward-facing step (MBFS) using nanofluids with different concentrations, diameters and types of nanoparticles. Their results referred that there was no recirculation region noticed for all nanofluids behind the step with  $0.48\mu\text{m}$ . Furthermore, it was

found that the nanofluid with lowest density provided the highest velocity for corresponding conditions. The maximum and minimum absolute peak velocities were found for SiO<sub>2</sub> and CuO nanofluid, respectively. The increase of Re number led to increase the Nusselt number and the skin friction coefficient. The higher volume fraction and/or smallest particle diameter provided the higher Nu number. The SiO<sub>2</sub> nanofluid showed the highest Nusselt number while CuO nanofluid was the last effective nanofluid. There was no effect of the nanofluid type, nanoparticle volume fraction and nanoparticle diameter observed on the skin friction coefficient.

Abu-Mulaweh et al. [32] reported experimental and numerical measurements for buoyancy-opposing laminar mixed convection flow over a vertical, two-dimensional forward-facing step. They outlined that as the buoyancy opposing force increased, as a result of increase in the wall temperature of the downstream plate, the recirculating flow region moved closer to the step and its length decreased. The length of recirculating flow region and the length of non-circulating flow region, decrease rapidly as the buoyancy level increased due to decrease in the free streamwise velocity and/or an increase in the downstream wall heating. The thickness of the recirculating flow region increased as the free stream velocity decreases and that region moved closer towards the step. On the other hand, the temperature gradient at the heated wall increases with increasing temperature difference. The results also showed that local Nusselt number decreased as the buoyancy force increased, while this trend was observed to reverse inside the recirculating flow region.

Recently Kherbeet et al. [33] performed a set of numerical simulations of 3D laminar mixed convection fluid flow over a horizontal microscale forward-facing step (MFFS) using nanofluids with different concentrations, particle diameters and particle types. They monitored that the velocity in the streamwise, transverse, and spanwise directions increased with increasing volume fraction. The maximum and minimum absolute peak velocities were found for SiO<sub>2</sub> nanofluid and pure EG, respectively. The SiO<sub>2</sub> nanofluid had the higher Nusselt number, which increased with increasing volume fraction and/or decreasing particle diameter. In contrast, the static pressure increased with increasing volume fraction and decreasing particle diameter.

Barton [34] presented investigation of predicts a variety of laminar flow with heat transfer; particle-laden flow; particle-laden flow with heat transfer, and particle-laden flow with heat

transfer and associated thermal effects for a BFS configuration. The thermal effects considered were thermophoresis and buoyancy effect. They found that the reattachment length increased almost linearly with the increasing of Re number. The center of the recirculation region moved downstream with increasing Re number due to adverse pressure gradient increased, and its size increased. The strength of the buoyancy effects decreased with Re number because Ri number was proportional to the inverse of  $Re^2$ . As Re number increased, the hot fluid was successfully transported downstream, and the buoyancy force significantly affects the lower reattachment length.

### **4.3 Forced convection**

There were many researchers considered the forced fluid flow over backward facing-step to study the varying in the fluid characteristics and reattachment length due to its importance in many applications. For instance, Armaly et al. [35] presented experimental and numerical investigation for laminar, transitional and turbulent flows of air in BFS channel. The velocity profile indicated that the flow separated at the step, resulting in one, two or three recirculation regions behind the step, and then redeveloped to a fully developed parabolic velocity profile in the large channel. The numerical results indicated that the length of the primary separated flow region was predicted to increase nonlinearly with Reynolds number up to  $Re \approx 420$ . The longitudinal dimensions of this additional region of separated flow were predicted to increase with Reynolds number up to  $Re \approx 980$ , while above this two more regions of recirculating flow are predicted.

Ruck and Makiola [36] presented experimental investigation of flow with particle dispersion in a single-sided BFS. The results illustrated that the reattachment length of the particle velocity field was effectively shortened with increasing particle diameter. The cross-sectional volume flux values based on larger particles led to an increase in measured volume flux (a contradiction to the continuity law) behind the step and deviations of more than 40% from the upstream values at  $Re_H > 45,000$  and  $70 \mu m$  particle diameter have been registered. The results for particle size distributions were given in the cumulative percentage curves showed that in the separation region significantly fewer bigger particles exist when compared to the distribution of the approach flow.



The numerical study of Gaber et al. [37] examined the laminar flows with recirculation regions. The results demonstrated that the decrease of the expansion ratio led to decrease the length of the recirculation region. The laminar reattachment length was relatively function of Re number, and the reattachment length increased with increasing Re number in the range of 100 to 400. The recirculation region for the inner-radius annular BFS was least sensitive to changes in Re number. The length of the recirculation region was intense function of Re and transverse curvature. However, the effect of transverse curvature was more than that associated with the expansion ratio because of the role of vortex stretching in axisymmetric geometries. In all their cases, the recirculation region increased in length with Re when the flow was laminar. Reynolds number was based on the maximum velocity upstream of the step and the outer radius of the annulus.

Another numerical investigation presented by Park et al. [38] of three-dimensional backward-facing step with both laminar and turbulent flow. The results demonstrated that for the Reynolds number range of 0–500, the reattachment length increases with the Reynolds number. The reattachment length in three-dimensional flow was slightly shorter than in two-dimensional flow. In case of turbulent flow, it was demonstrated that the standard model predicts slightly larger velocities in the shear layer. In the three-dimensional case, the reattachment length predicted using the non-linear model did not differ greatly from the one with the standard model. The reattachment length was much shorter in three-dimensional case than in the corresponding two-dimensional case. However, the location of corner vortices changed sensitively with the Re number.

Chiang et al. [39] examined the effect of incompressible fluid in 3D channels having BFS with different spans. They concluded that the flow separation-attachment occurred on the roof of channel with regardless of the values of the Re numbers, but was confined only to the end wall region. Interior saddles were also detected. A collection of them forms a global line of separation which suggested a mechanism for the development of truly three-dimensional flow to the subsequent flow instabilities on increase of Re numbers. Chiang and Sheu [40] presented a numerical investigation of laminar transient flow over a BFS. They stated that Re number increased the longitudinal vortices can evolve to the extent that the two dimensional character of the flow was largely destroyed. The reattachment length on the mid –plane has a marked variation with the coordinate  $y$ . The secondary separation bubble on the roof of the channel, it was only visible near the end-wall. The secondary flow patterns were provided the evidence of the complex interaction

of the end-wall induced spiraling vortices with the flow through the three-dimensional channel expansion.

Nie and Armaly [41] presented a simulation of 3D laminar forced flow adjacent to BFS in rectangular duct to study the effects of step height on the flow and heat transfer characteristics. They confirmed that the primary reattachment length increased with increasing step height. The results showed as the step height increases the maximum Nu number increased and its location on the stepped wall moved further downstream. The 3D feature inside the primary recirculation region became more pronounced with the increasing in step height. A maximum friction coefficient developed along the centerline of the duct and its magnitude increased as the step height increased and its position moved further downstream as the step height increases. The friction coefficient downstream from reattachment line and outside the primary recirculation flow region decreased along the centerline with increasing step height. The friction coefficient on the stepped wall inside the primary recirculation region became greater as the step height increased.

Tylli et al. [42] investigated numerically and experimentally the effect of sidewalls on flow structure of three-dimensional laminar flow over a BFS. Their experiments showed that the flow was steady for Reynolds numbers less than 800. At  $Re < 400$ , the sidewall effects did not affect the structure of laminar flow in the channel midplane. The two-dimensional midplane showed that at higher Reynolds numbers, laminar flow was characterized by sidewall separation and the formation of a recirculation zone, which, however, did not penetrate up to the channel midplane. In the region close the sudden expansion, fluid elements close to the sidewalls were engulfed in the primary recirculation region and follow a spiraling motion toward the channel midplane finally exiting the recirculation zone.

Armaly et al. [43] reported a measurement for 3D laminar separated airflow adjacent to BFS using two-component laser Doppler velocimeter. The results showed that for  $Re \leq 98.5$ , there was no recirculation flow region adjacent to the sidewall. However, at  $Re = 190$ , a small recirculation flow region was detected in the upper corner of the sidewall. The size of sidewall recirculation flow region increased as Re number increased. The measurements of Nie and Armaly [44] denoted that the velocity distribution at the upstream section of BFS starts to deviate from laminar fully developed flow distribution as Re number increased indicating transition from laminar to turbulent

flow regime at the upstream section of the step. In comparison with the reattachment point for 2D flow the 3D flow results at the center of the test section were slightly higher in the laminar flow regime, significantly lower in the transition flow regime and slightly lower in fully turbulent flow regime. The results pointed out that as Re number increased, the size of the reverse flow region adjacent to the sidewall and the flat wall in this geometry increased and moved further downstream in the laminar flow regime and remained constant or diminished in the turbulent flow regime.

Saldana et al. [45] focused on forced convection flow over 3D BFS. The results referred that the higher value of shear stress was associated with higher Re number. The peak of spanwise average Nusselt number distribution was moved further downstream of the backstep as Re number was increased. The maximum spanwise average Nusselt number occurred inside the primary recirculation zone adjacent to the backstep. A small recirculation zone was located in the vicinity of the bottom wall and this zone become larger as Re number increased. The negative zone for u-velocity profile in the vicinity of the bottom wall was associated with the effects of primary recirculation zone. This zone being more pronounced and the recirculation was also larger as the Re number increased.

Lan et al. [46] simulated a 3D turbulent forced convection in a duct using a  $k-\epsilon$  turbulence model with a BFS. They illustrated that the convective heat transfer was enhanced by increasing the fluid velocity. The increase in Re number caused an increase in both local wall Nusselt number and spanwise velocity component on that plane. The aspect ratio influenced significantly the magnitude of the spanwise velocity component at the near-wall plane but has only small influence on local wall Nusselt number. Reynolds number has little effect on reattachment length and it has significant effect on the heat transfer, the bulk air temperature and the bottom wall temperature. The effect of aspect ratio on the local Nusselt number was neglected at the center of the duct but it became significant near the side wall.

Numerically, Al-aswadi et al. [47] investigated a 2D laminar forced convection over a horizontal backward facing step in duct using various types of nanofluids. They displayed that there was a recirculation region developed behind the step and the size of the recirculation region decreased as the distance between the step and the stepped wall increased until the flow reaches the reattachment point where the flow exhibit zero velocity. It was noticed that  $\text{SiO}_2$  nanofluid has the

highest absolute velocity while Au nanofluid has the lowest value. The skin friction coefficient decreased with Reynolds number. Friction coefficient found to be increased monotonically and reached its maximum peak as the distance downstream from the step increased. Then it decreased until it reached the minimum peak due to the recirculation flow where there was change in the velocity distribution and the minimum peak occurred due to the reattachment point where the velocity was almost equal to zero.

The results of MBFS of Xue et al. [48] revealed that at Knudsen number ( $Kn = 0.01$ ), there was nonlinear distributions of pressure were observed before and after the step, and a significant pressure drop takes place at the step. The vertical distribution of the velocity in different cross sections along the channel showed that there was a significant drop of vertical velocity near the step can be observed due to the sudden expansion of the gas flow. However, the vertical velocities near both the inlet and outlet appeared as sinusoid. When  $Kn \leq 0.01$ , there was a low-speed region can be observed with negative streamwise velocity behind the step, which was the direct result of separation, recirculation, and reattachment in a normal-scale BFS flow. However, at microscale, as Knudsen number increased, the recirculation region shrink. There was a jump in the pressure and velocity observed at various Knudsen numbers, and the large Knudsen number the bigger jump was. Xue and Chen [49] simulated the MBFS flows in both slip and transition flow regimes. The results showed that the flow recirculation, separation, and the reattachment, disappeared as  $Kn > 0.1$ . A sudden jump of pressure and velocity behind the step was observed which may attribute to the nature of the molecule distribution near the back of the step. As the region is surrounded by two solid walls, the number density of molecular in the Knudsen layer was statistically higher. The highest jump in temperature and velocity was experienced in the corner behind the step, due to the probabilistic behavior of molecule movement in the Knudsen layer. Furthermore, the compressibility has significant effect on recirculation region, pressure drop, and reattachment distance in the slip flow regime, but would be neglected in the transition flow regime, where the rarefaction effect is dominant.

Ravindran [50] presented investigation of design and implementation of reduced-order optimal controller for flow separation. Two different types of surface actuation are considered - tangential blowing and suction through a single slot. The results clearly indicated that flow separation is mitigated by the control action. The re-attachment length was reduced by more than 75% compared

to the uncontrolled case. The results indicated that control was most effective when it is placed near the stagnation point. The tangential blowing control was found to be more effective than the suction control and results in substantial reduction in wake spread behind the step. As indicated in the flow fields, separation was effectively eliminated by the optimal tangential blowing control. Substantial reduction in the wake spread was monitored. The re-attachment length has been reduced by more than 99% compared to the uncontrolled case.

Yallmaz and Hakan [51] studied the turbulent forced heat transfer for double FFS flow considering two-dimensional, steady-state, and incompressible flow. They illustrated that there was more than one circulation obtained on the contrary of BFS. Because of the small height ratio of the step, the flow near the top wall of the channel did not take effect from the step and flow rate increases due to contraction. The values of pressure coefficients were decreased in the horizontal direction of the channel, and the pressure coefficients were increased with the increasing of Re number. The local Nusselt number increased with the increasing Re number. For higher Re numbers, Nusselt number was increased with the increasing of step height due to, if the step height increased, the flow circulation increased and eddies enhanced the heat transfer. Heat transfer was enhanced with Re number and higher heat transfer was obtained for the higher step height except near the boundary of the step for all Re numbers. The second step enhanced the heat transfer at the same Re number.

Recently Kherbeet et al. [52] and Kherbeet et al. [53] investigated experimentally and numerically the flow and heat transfer characteristics of nanofluid laminar flow over the microscale backward-facing step (MBFS) and microscale forward-facing step (MFFS). In this study the duct inlet and the step height were maintained at 400  $\mu\text{m}$  and 600  $\mu\text{m}$  respectively. All the walls considered adiabatic except the downstream wall exposed to uniform heat flux. The study conducted at Reynolds number range of 280 - 470. The distilled water is considered as a base fluid with two types of nanoparticles  $\text{SiO}_2$  and  $\text{Al}_2\text{O}_3$  suspended in the base fluid. The particle diameter is 30 nm and the range of nanoparticles volume fraction varied from 0 to 0.01. The results revealed that the water- $\text{SiO}_2$  nanofluid has the highest Nusselt number and the Nusselt number increase with increases of volume fraction. The water- $\text{SiO}_2$  nanofluid with higher volume fraction has the highest Nusselt number. The friction factor of water- $\text{Al}_2\text{O}_3$  was higher than of water- $\text{SiO}_2$  mixture. The experimental results showed with using MFFS geometry, 30.6% enhancement in the average Nusselt number can be obtained with using water- $\text{SiO}_2$  nanofluid at 1% volume fraction.

Kherbeet et al. [54] presented experimental comparison of the effects of laminar nanofluid flow over the MBFS and MFFS on the heat transfer characteristics. The experiments were implemented on MBFS and MFFS with a step height of 600  $\mu\text{m}$ . Both MBFS and MFFS have the upstream and downstream lengths of 0.1 m and 0.15 m respectively. The Reynolds number ranged of 280–480. The concentrations of SiO<sub>2</sub> nanoparticle valued at 0.005 and 0.01 with a diameter of 30 nm were suspended in a distilled water. The results revealed. The revealed that the highest Nusselt number is obtained through the use of the MFFS, which is approximately twice that of MBFS. However, the friction factor recorded a higher value for MFFS.

## 5. Conclusion

A comprehensive review of previous efforts was presented in this work for different convective flow regimes and heat transfer through a duct having backward- and forward-facing steps. A detailed summary of the effects of several parameters such as; step height, Reynolds number, expansion ratio, inclination angle of the channel, inclination angle of the step wall, Prandtl number, nanofluids, and buoyancy-force (assisting and opposing) on the flow and thermal fields downstream of the step has been presented. This review clearly shows that the flow over a forward-facing step has received little attention comparing to that of the backward-facing step cases. This may due to, in the forward-facing step geometry, there is more than one recirculation regions develops, which make it more complicated for studying than the backward facing step geometry in which only one recirculation region occurs behind the step. Furthermore, there is no previous works discussed the flow and heat transfer over the microscale forward-facing steps. Hence, further work is needed in the area of research.

It was also observed from the open literature that most researchers have considered the conventional fluids to study the heat transfer and fluid flow characteristics over BFS. However, there is no previous works discussed three-dimensional flow and heat transfer characteristics over microscale backward- and forward-facing step utilizing nanofluids numerically or experimentally. Therefore, further numerical and experimental investigations of the flow over MBFS and MFFS using nanofluids are needed.

## References

- [1] B. Blackwell and B. Armaly, "Computational aspects of heat transfer benchmark problems," ASME HTD, vol. 258, pp. 1-10, 1993a.
- [2] B. Blackwell and B. Armaly, "Benchmark problem definition and summary of computational results for mixed convection over a backward facing step," ASME HEAT TRANSFER DIV PUBL HTD, ASME, NEW YORK, NY,(USA), 1993, vol. 258, pp. 1-10, 1993b.
- [3] H. I. Abu-Mulaweh, "A review of research on laminar mixed convection flow over backward- and forward-facing steps," Int. J. Therm. Sci., vol. 42, no. 9, pp. 897–909, 2003.
- [4] H. Mohammed, A. Al-aswadi, N. Shuaib, and R. Saidur, "Convective heat transfer and fluid flow study over a step using nanofluids: A review," Renewable and Sustainable Energy Reviews, vol. 15, pp. 2921-2939, 2011.
- [5] J. Saldana, N. Anand, and V. Sarin, "Numerical simulation of mixed convective flow over a three-dimensional horizontal backward facing step," Journal of Heat Transfer, vol. 127, p. 1027, 2005a.
- [6] E. Abu-Nada, "Entropy generation due to heat and fluid flow in backward facing step flow with various expansion ratios," Int. J. Exergy, vol. 3, no. 4, p. 419, 2006.
- [7] E. Abu-Nada, "Application of nanofluids for heat transfer enhancement of separated flows encountered in a backward facing step," Int. J. Heat Fluid Flow, vol. 29, no. 1, pp. 242–249, 2008.
- [8] E. Abu-Nada, "Investigation of entropy generation over a backward facing step under bleeding conditions," Energy Convers. Manag., vol. 49, no. 11, pp. 3237–3242, 2008.

- [9] E. Abu-Nada, a. Al-Sarkhi, B. Akash, and I. Al-Hinti, "Heat Transfer and Fluid Flow Characteristics of Separated Flows Encountered in a Backward-Facing Step Under the Effect of Suction and Blowing," *J. Heat Transfer*, vol. 129, no. November 2007, p. 1517, 2007.
- [10] Y. T. Chen, J. H. Nie, B. F. Armaly, and H. T. Hsieh, "Turbulent separated convection flow adjacent to backward-facing step—effects of step height," *Int. J. Heat Mass Transf.*, vol. 49, no. 19–20, pp. 3670–3680, 2006.
- [11] H. Iwai, K. Nakabe, and K. Suzuki, "Flow and heat transfer characteristics of backward-facing step laminar flow in a rectangular duct," *Int. J. Heat Mass Transf.*, vol. 43, no. 3, pp. 457–471, 2000.
- [12] T. Y. Hsieh, Z.-C. Hong, and Y.-C. Pan, "Flow Characteristics of Three-Dimensional Microscale Backward-Facing Step Flows," *Numer. Heat Transf. Part A Appl.*, vol. 57, no. 5, pp. 331–345, 2010.
- [13] H. Abu-Mulaweh, B. Armaly, and T. Chen, "Measurements of laminar mixed convection in boundary-layer flow over horizontal and inclined backward-facing steps," *International Journal of Heat and Mass Transfer*, vol. 36, pp. 1883-1895, 1993b.
- [14] H. Abu-Mulaweh, B. Armaly, and T. Chen, "Turbulent mixed convection flow over a backward-facing step- the effect of the step heights," *International Journal of Heat and Mass Transfer*, vol. 44, pp. 2661-2669, 2001.
- [15] A. Sh. Kherbeet, H. A. Mohammed, K. M. Munisamy, and B. H. Salman, "The effect of step height of microscale backward-facing step on mixed convection nanofluid flow and heat transfer characteristics," *Int. J. Heat Mass Transf.*, vol. 68, no. 0, pp. 554–566, 2014.
- [16] H. I. Abu-Mulaweh, "Turbulent mixed convection flow over a forward-facing step - The effect of step heights," *Int. J. Therm. Sci.*, vol. 44, pp. 155–162, 2005.
- [17] H. Stürer, A. Gyr, and W. Kinzelbach, "Laminar separation on a forward facing step," *Eur. J. Mech. - B/Fluids*, vol. 18, no. 4, pp. 675–692, 1999.
- [18] S. A. Gandjalikhan Nassab, R. Moosavi, and S. M. Hosseini Sarvari, "Turbulent forced convection flow adjacent to inclined forward step in a duct," *Int. J. Therm. Sci.*, vol. 48, no. 7, pp. 1319–1326, 2009.
- [19] M. Sherry, D. Lo Jacono, and J. Sheridan, "An experimental investigation of the recirculation zone formed downstream of a forward facing step," *J. Wind Eng. Ind. Aerodyn.*, vol. 98, no. 12, pp. 888–894, 2010.



- [20] A. M. Taher and I. G. Adam, "Numerical Investigations of a Turbulent Flow over Triple Forward Facing Step," vol. 5, pp. 303–307, 2010.
- [21] H. Hattori and Y. Nagano, "Investigation of turbulent boundary layer over forward-facing step via direct numerical simulation," *Int. J. Heat Fluid Flow*, vol. 31, no. 3, pp. 284–294, 2010.
- [22] B. Hong, B. F. Armaly, and T. S. Chen, "Laminar mixed convection in a duct with a backward-facing step: the effects of inclination angle and Prandtl number," *Int. J. Heat Mass Transf.*, vol. 36, no. 12, pp. 3059–3067, 1993.
- [23] H. Iwai, K. Nakabe, K. Suzuki, and K. Matsubara, "The effects of duct inclination angle on laminar mixed convective flows over a backward-facing step," *Int. J. Heat Mass Transf.*, vol. 43, pp. 473–485, 2000.
- [24] Lin, J. T., Armaly, B. F., & Chen, T. S. (1991). Mixed convection heat transfer in inclined backward-facing step flows. *International journal of heat and mass transfer*, 34(6), 1568-1571.
- [25] H. Abu-mulaweh, "Effects of backward- and forward-facing steps on turbulent natural convection flow along a vertical flat plate.," *Int. J. Therm. Sci.*, vol. 41, no. 4, pp. 376–385, 2002.
- [26] C. Hung and K. Kuei, "Transient mixed convection of a backward-facing step with a periodically heated wall," *Acta Mechanica*, vol. 120, pp. 233-241, 1997.
- [27] K. Khanafer, B. Al-Azmi, A. Al-Shammari, and I. Pop, "Mixed Convection Analysis of Laminar Pulsating Flow and Heat Transfer over a Backward-facing Step," *Int. J. Heat Mass Transf.*, vol. 51, no. 25–26, pp. 5785–5793, 2008.
- [28] K.-Y. Kung, X. Cheng-Hsing Hsu, and H. L. Chiang, "Transient mixed convection flow of a second grade viscoelastic fluid past an inclined backward facing step," *Int. J. Non. Linear. Mech.*, vol. 39, no. 3, pp. 427–439, 2004.
- [29] H. Abu-Mulaweh, B. Armaly, and T. Chen, "Measurements in buoyancy-assisting laminar boundary layer flow over a vertical backward-facing step--Uniform wall heat flux case," *Experimental Thermal and Fluid Science*, vol. 7, pp. 39-48, 1993a.
- [30] H. Abu-Mulaweh, B. Armaly, and T. Chen, "Measurements in buoyancy-opposing laminar flow over a vertical backward-facing step," *Journal of Heat Transfer*, vol. 116, pp. 247-250, 1994.

- [31] A. Sh. Kherbeet, H. A. Mohammed, and B. H. Salman, "The effect of nanofluids flow on mixed convection heat transfer over microscale backward-facing step," *International Journal of Heat and Mass Transfer*, vol. 55, pp. 5870–5881, 2012.
- [32] H. Abu-Mulaweh, B. Armaly, and T. Chen, "Measurements in buoyancy-opposing laminar flow over a vertical forward-facing step," *International Journal of Heat and Mass Transfer*, vol. 39, pp. 1805-1813, 1996.
- [33] A. Sh. Kherbeet, H. A. Mohammed, K. M. Munisamy, and B. H. Salman "Combined convection nanofluid flow and heat transfer over microscale forward-facing step." *International Journal of Nanoparticles* 7.1 (2014): 1-25.
- [34] I. E. Barton, "Laminar flow over a backward-facing step with a stream of hot particles," *Int. J. Heat Fluid Flow*, vol. 18, no. 1990, pp. 400–410, 1997.
- [35] B. Armaly, F. Durst, J. Pereira, and B. Schönung, "Experimental and theoretical investigation of backward-facing step flow," *Journal of Fluid Mechanics*, vol. 127, no. 1. pp. 473–496, 1983.
- [36] B. Ruck and B. Makiola, "Particle dispersion in a single-sided backward-facing step flow," *Int. J. Multiph. Flow*, vol. 14, no. 6, pp. 787–800, 1988.
- [37] A. Gaber Mohamed, D. Valentine, and R. Hassel, "Numerical study of laminar separation over an annular backstep," *Computers & Fluids*, vol. 20, pp. 121-143, 1991.
- [38] S. O. Park, K. S. Lim, and R. H. Pletcher, "A Numerical Study of Three-Dimensional Backward-Facing Step Flow," vol. 7, no. I, pp. 1–13, 1993.
- [39] T. P. Chiang, T. W. H. Sheu, and S. F. Tsai, "Topological flow structures in backward-facing step channels," *Comput. Fluids*, vol. 26, no. 4, pp. 321–337, 1997.
- [40] T. P. Chiang and T. W. H. Sheu, "Time evolution of laminar flow over a three-dimensional backward-facing step," *Int. J. Numer. Methods Fluids*, vol. 31, no. 4, pp. 721–745, 1999.
- [41] J. H. Nie and B. F. Armaly, "Three-dimensional convective flow adjacent to backward-facing step - Effects of step height," *Int. J. Heat Mass Transf.*, vol. 45, no. 12, pp. 2431–2438, 2002.
- [42] N. Tylli, L. Kaiktsis, and B. Ineichen, "Sidewall effects in flow over a backward-facing step: Experiments and numerical simulations," *Phys. Fluids*, vol. 14, no. 11, pp. 3835–3845, 2002.
- [43] B. F. Armaly, A. Li, and J. H. Nie, "Measurements in three-dimensional laminar separated flow," *Int. J. Heat Mass Transf.*, vol. 46, no. 19, pp. 3573–3582, 2003.

- [44] J. H. Nie and B. F. Armaly, "Reverse flow regions in three-dimensional backward-facing step flow," *Int. J. Heat Mass Transf.*, vol. 47, no. 22, pp. 4713–4720, 2004.
- [45] J. Saldana, N. Anand, and V. Sarin, "Forced Convection Over a Three-Dimensional Horizontal Backward Facing Step," *International Journal for Computational Methods in Engineering Science and Mechanics*, vol. 6, pp. 225-234, 2005b.
- [46] H. Lan, B. F. Armaly, and J. A. Drallmeier, "Three-dimensional simulation of turbulent forced convection in a duct with backward-facing step," *Int. J. Heat Mass Transf.*, vol. 52, no. 7–8, pp. 1690–1700, 2009.
- [47] A. A. Al-aswadi, H. A. Mohammed, N. H. Shuaib, and A. Campo, "Laminar forced convection flow over a backward facing step using nanofluids," *Int. Commun. Heat Mass Transf.*, vol. 37, no. 8, pp. 950–957, 2010.
- [48] H. Xue, B. Xu, Y. Wei, and J. Wu, "Unique Behaviors of a Backward-Facingstep Flow At Microscale," *Numer. Heat Transf. Part A Appl.*, vol. 47, no. 3, pp. 251–268, 2005.
- [49] H. Xue and S. Chen, "Dsmc Simulation of Microscale Backward-Facing Step Flow," *Microscale Thermophys. Eng.*, vol. 7, no. 1, pp. 69–86, 2003.
- [50] S. S. Ravindran, "Control of flow separation over a forward-facing step by model reduction," *Comput. Methods Appl. Mech. Eng.*, vol. 191, pp. 4599–4617, 2002.
- [51] I. Yılmaz and H. F. Öztöp, "Turbulence forced convection heat transfer over double forward facing step flow," *Int. Commun. Heat Mass Transf.*, vol. 33, no. 4, pp. 508–517, 2006.
- [52] A. Sh. Kherbeet, H. A. Mohammed, B. H. Salman, H. E. Ahmed, & O. A. Alawi, "Experimental and numerical study of nanofluid flow and heat transfer over microscale backward-facing step." *International Journal of Heat and Mass Transfer* 79 (2014): 858-867.
- [53] A. Sh. Kherbeet, H. A. Mohammed, K. M. Munisamy, R. Saidur, B. H. Salman, and I. M. Mahbubul. "Experimental and numerical study of nanofluid flow and heat transfer over microscale forward-facing step." *International Communications in Heat and Mass Transfer* 57 (2014): 319-329.
- [54] A. Sh. Kherbeet, H. A. Mohammed, B. H. Salman, Hamdi E. Ahmed, Omer A. Alawi, and M. M. Rashidi "Experimental study of nanofluid flow and heat transfer over microscale backward-and forward-facing steps." *Experimental Thermal and Fluid Science* 65 (2015): 13-21.

