



Deposited via The University of Sheffield.

White Rose Research Online URL for this paper:

<https://eprints.whiterose.ac.uk/id/eprint/116370/>

Version: Accepted Version

---

**Proceedings Paper:**

Nikolaidis, V.C., Papanikolaou, N., Safigianni, A.S. et al. (2017) Influence of fault-ride-through requirements for distributed generators on the protection coordination of an actual distribution system with reclosers. In: 2017 IEEE Manchester PowerTech Proceedings. IEEE PowerTech Manchester 2017, June 18-22, 2017, Manchester, UK. IEEE. ISBN: 978-1-5090-4238-8.

<https://doi.org/10.1109/PTC.2017.7981045>

---

© 2017 IEEE. Personal use of this material is permitted. Permission from IEEE must be obtained for all other users, including reprinting/ republishing this material for advertising or promotional purposes, creating new collective works for resale or redistribution to servers or lists, or reuse of any copyrighted components of this work in other works. Reproduced in accordance with the publisher's self-archiving policy.

**Reuse**

Items deposited in White Rose Research Online are protected by copyright, with all rights reserved unless indicated otherwise. They may be downloaded and/or printed for private study, or other acts as permitted by national copyright laws. The publisher or other rights holders may allow further reproduction and re-use of the full text version. This is indicated by the licence information on the White Rose Research Online record for the item.

**Takedown**

If you consider content in White Rose Research Online to be in breach of UK law, please notify us by emailing [eprints@whiterose.ac.uk](mailto:eprints@whiterose.ac.uk) including the URL of the record and the reason for the withdrawal request.

# Influence of Fault-Ride-Through Requirements for Distributed Generators on the Protection Coordination of an Actual Distribution System with Reclosers

V. C. Nikolaidis, N. Papanikolaou, A. S. Safigianni

Dept. of Electrical and Computer Engineering  
Democritus University of Thrace  
Xanthi, Greece  
vnikolai@ee.duth.gr

A. G. Paspatis, G. C. Konstantopoulos

Dept. of Automatic Control and Systems Engineering  
The University of Sheffield  
Sheffield, UK  
apaspat1@sheffield.ac.uk

**Abstract**—This paper analyses the existing protection scheme of a real distribution system with distributed generators, in Greece. Network protection utilizes three successive reclosers at the main trunk and fuses at the laterals. The generating units are protected by overcurrent and voltage/frequency relays. The analysis focuses on the fault-ride-through capability of the generating units and proposes the resetting of the generators and network protection relays so as to conform to the requirements imposed by distribution system operators and international standards. The proposed protection system guarantees selectivity for any short-circuits occurring inside or outside the distribution system, irrespective if the generating units are connected to the network or not. Meaningful conclusions are derived from the application of the proposed protection coordination principle.

**Index Terms**—Distributed Generation, Distribution Systems, Fault-Ride-Through, Reclosers Coordination.

## I. INTRODUCTION

A conventional overcurrent protection scheme designed for radial distribution lines is usually based on the use of a recloser, at the beginning of the feeder, which is coordinated with the downstream protection means (overcurrent relays, reclosers, and/or sectionalisers) at the main line and with the fuses at the laterals [1]. The integration of Distributed Generation (DG) in distribution networks leads to problems related to protection coordination that are difficult to be solved by applying conventional protection techniques [2], especially when DG penetration level increases and island mode of operation is expected [3]. It is difficult to coordinate the recloser at a radial distribution line with the fuses at the laterals when DG units are present in the line. In [4], microprocessor-based reclosers with adaptive capabilities have been proposed for achieving selectivity in a radial distribution network with DG. This scheme applies effectively, but it suggests that the DG units will be disconnected before the first reclosing operation. Non-adaptive microprocessor-based reclosers in conjunction with directional elements have been proposed in [5]. Coordination

between reclosers and fuses has been obtained in [6] with the use of synchronized measurements and off-line design calculations. It is proposed in [7] to replace the fuses at the laterals, where DG is connected, with numerical reclosers and relays in order to maintain coordination between the overcurrent protection devices. This methodology was tested in two template distribution systems and seems to work adequately, despite the fact that some fuse fatigue issues could not be avoided.

This work aims to investigate the FRT capabilities of the generating units in a real distribution system in Greece. Since there is no standard framework adopted in Greece, regarding FRT requirements of DG units connected to distribution systems, there is a clear need for developing standard guidelines. Furthermore, this paper aims to illustrate that FRT requirements can be achieved in actual distribution networks with DG units by applying simple modifications in already existing protection DG relays and network reclosers. It is intention of this work to investigate if FRT can be preserved for faults inside the radial distribution feeder, in a way to guarantee an islanded network operation in the future. Similar research in this field tried successfully to restore recloser-fuse coordination [4], [5], [6], [7] without considering any time limitations imposed by FRT requirements. In [8], FRT requirements have been indirectly considered but only faults outside of the radial feeders were tested. An effective protection strategy, where FRT and islanding have been taken together into account, is proposed in [9], but the methodology assumes communication between the relays.

The rest of this paper has been organized as follows. The detailed description of the distribution system under investigation is presented in Section II. Section III addresses the existing protection scheme and proposes its resetting in accordance to FRT requirements. Section IV includes simulation results, while Section V provides the derived conclusions.

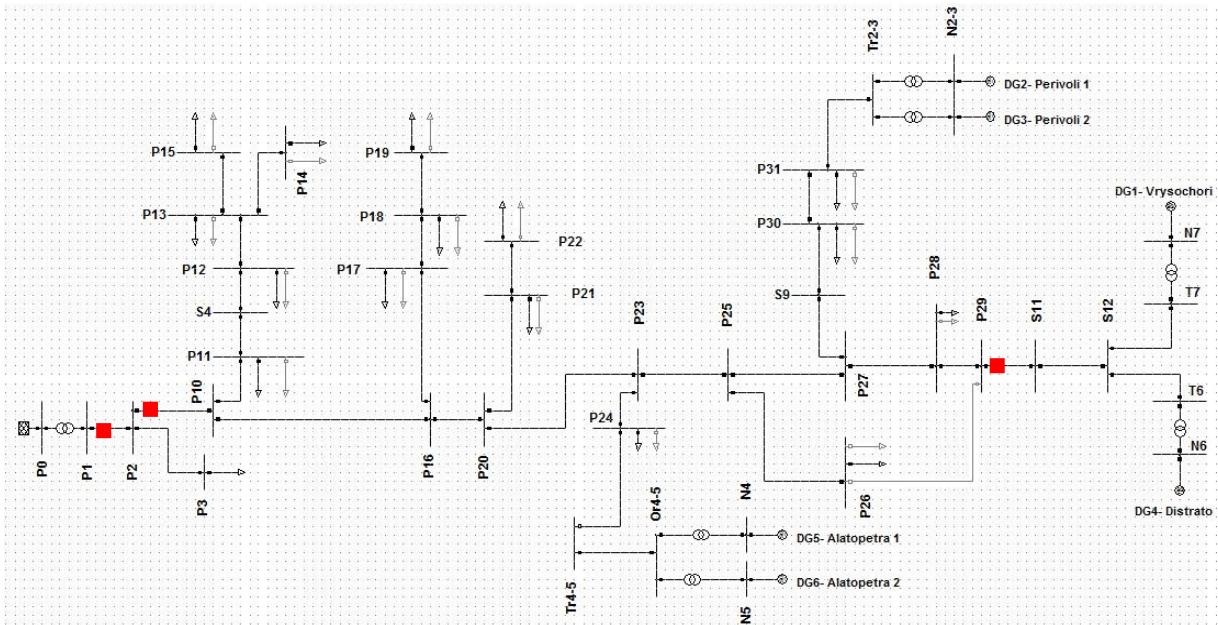

Figure 1. Distribution system under investigation.

## II. EXAMINED DISTRIBUTION SYSTEM

### A. System Description

The investigation in this paper concerns an actual 20 kV distribution system situated in West Macedonia, Greece (Fig. 1), to which six synchronous hydro generators are connected. Details about the technical data of this distribution system can be found in [10]. It should be noted that the generation capacity is much greater than the total load demand, meaning that under specific generation and load conditions, reverse power flow is expected.

### B. Existing Protection System

The main feeder is originally protected by three reclosers. The first recloser (Basler BE1-851) is installed in the main substation (bus P1) to protect the whole feeder from faults occurring along the line from its very beginning. The second recloser (Cooper F4) is located at bus P2 that is at the main trunk, very close to the initial recloser. The third recloser (Cooper F4) is located at bus P29, close to the end of the main trunk and near to the area where the DG units are placed. The reclosers are named as RP1, RP2 and RP29 respectively, based on the buses close to which they are installed. The exact position of the reclosers is indicated in Fig. 1 with a red rectangle. The settings of the phase and ground overcurrent elements of the reclosers are tabulated in Table A1 in the Appendix. The operating characteristics of the ground elements on a time-overcurrent plot are shown in Fig. 2. The phase elements will be shown later in the paper. Note that RP1 has the same time-current characteristic for fast and slow operation.

There are also expulsion fuses installed at the laterals, which have been taken into consideration in this work, despite the fact that we are not interested to focus on coordination issues between the reclosers and the fuses. The local DSO adopts a fuse-saving philosophy meaning that the fuses melt before any of the reclosers will begin its slow operation.

Each DG unit is protected by a common combination of a voltage/frequency, an overcurrent, and a residual voltage relay. In most of these elements, multiple stages are set. Table A2 in the Appendix summarizes the settings of those relays for each DG unit.

### C. Existing Protection Scheme Evaluation

Selectivity is checked to verify that under all possible system operating modes, including operation of the DG units, the existing protection scheme adequately protects system components and that it is fully coordinated. Only MV protection equipment is considered in this analysis, since LV protection operation is out of the scope of this study. In other words, it is assumed that coordination between the MV and LV protection devices exists always. Coordination with the utility network line distance protection is also examined.

For the evaluation, the maximum and minimum phase and ground short-circuit currents, sensed by each relay pair or relay-fuse pair, are simulated to determine the tripping time of the protection devices. Coordination is guaranteed if adequate Coordination Time Interval (CTI) between successive (upstream-downstream) protection devices in the MV system is observed for all simulated short-circuits. The simulations showed that the reclosers are properly set and that selectivity is guaranteed for all examined fault types and locations (inside the MV network), including specific non-solid short-circuits.

Let us give an example of adequate coordination between the reclosers RP1, RP2, and RP29. Fig. 3 shows the reclosing sequence of all three reclosers for a permanent, solid, three-phase short-circuit at time  $t = 1$  s, close-in to RP29. In this figure, the rms current measured by the reclosers (current at the primary side of the current transformer) is shown. In the same figure, “FT” and “ST” stands for the fast trip and the slow trip respectively, while “O” and “L” means open and lockout time interval respectively.

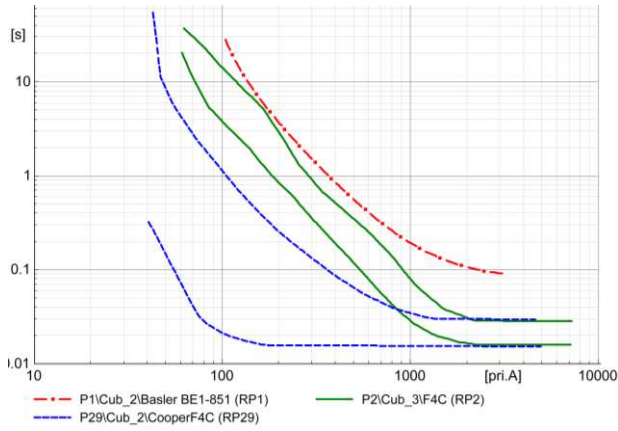

Figure 2. Ground element characteristics of the reclosers.

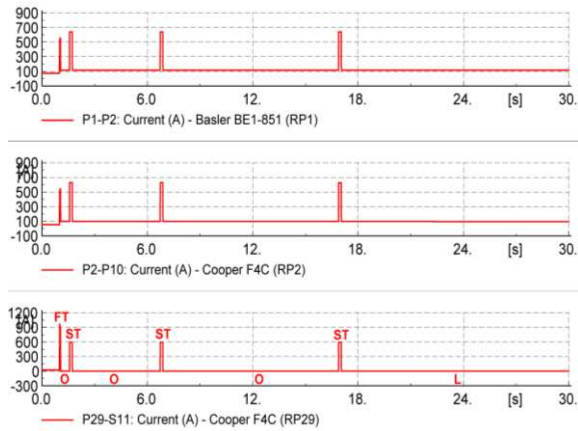

Figure 3. Reclosing operations due to a 3PH fault close-in to RP29

Fig. 4 depicts the phase element time-overcurrent characteristics of the reclosers, from which the tripping time for this particular short-circuit can be determined. It can be seen that RP29, which is closer to the fault, trips first (in 53 ms) according to its fast characteristic. Only RP29 performs reclosing operations, since the faults is located downstream of RP29. Hence, after three delayed subsequent reclosing operations, RP29 switches to a lockout state.

It should be noted that for all simulated short-circuits, if DG units are connected to the 20 kV distribution network, at least one of them will be tripped after 100 ms due to undervoltage protection. In the abovementioned short-circuit scenario, the units DG1 and DG4 are tripped by the undervoltage relay during the first open time interval of RP29.

### III. FAULT-RIDE-THROUGH CONSIDERATIONS

#### A. Fault-Ride-Through Requirements

According to recent DSO practices, all generating plants connected to MV networks must remain connected to the grid during a fault, for a time that depends on the voltage dip caused by the fault. Otherwise, the instant disconnection of a large amount of DG due to a fault may threaten the stability of the whole system [3]. Many countries around the world have started standardising Fault-Ride-Through (FRT) requirements [11], but until today there is not a global standard developed, although there is a continuing progress on this [12], [13], [14].

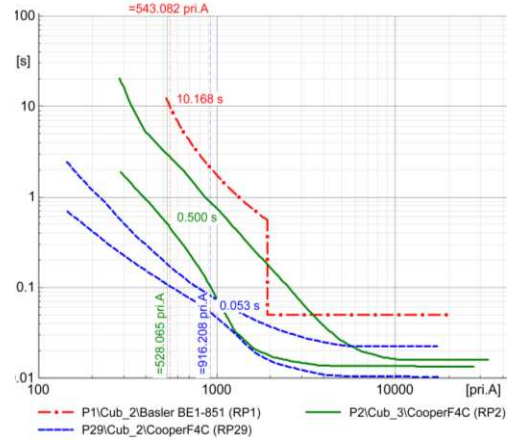

Figure 4. Tripping times for a 3PH fault close-in to RP29

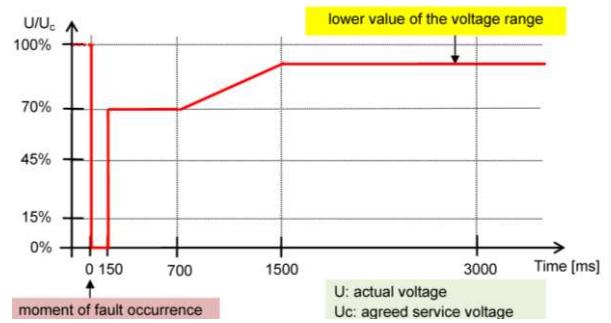

Figure 5. FRT guidelines

Concerning the FRT capability of type-1 (synchronous machine based) generating plants, technical guideline [15] indicates the graph depicted in Fig. 5. This graph determines the time in ms that a generator must remain connected to the grid with respect to the per unit voltage drop caused at the generator's connection point due to a short-circuit fault in the grid. For instance, a generator must remain connected to the network for a time duration of at least 150 ms in case of a solid short-circuit that would cause a 100% voltage drop at the generator's point of connection.

There is no standard framework in Greece regarding FRT requirements of DG units connected to distribution systems. Therefore, in this paper, we adopt the voltage related FRT requirements of [15], which are quite challenging to obtain.

#### B. Modification of Protection Settings

It has been addressed in Section III.B that, in case of a short-circuit fault in the MV distribution network, at least one hydro generator will be tripped due to undervoltage protection. For instance, it has been shown that if a permanent, solid, three-phase fault occurs in front of RP29, units DG1 and DG4 will be tripped. Indeed, Fig. 6 illustrates the response of the generator terminal bus voltages for this particular fault event. Green (solid), blue (dash-dotted), black (dotted), and purple (dashed) curve represents the terminal voltage response of DG4, DG1, DG2 and DG5 respectively. The vertical dashed line passes from  $t = 1.1$  s, expressing a time delay exactly equal to 100 ms after the fault incidence, whereas the horizontal dashed line expresses the undervoltage setting (0.9 pu) of the generator voltage relays.

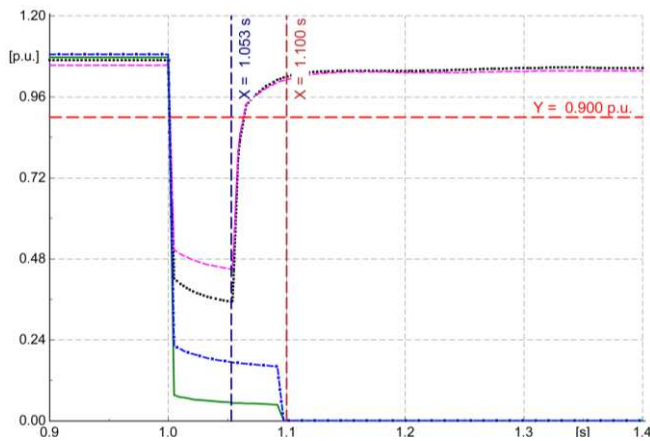

Figure 6. Voltage response for a 3PH fault close-in to RP29

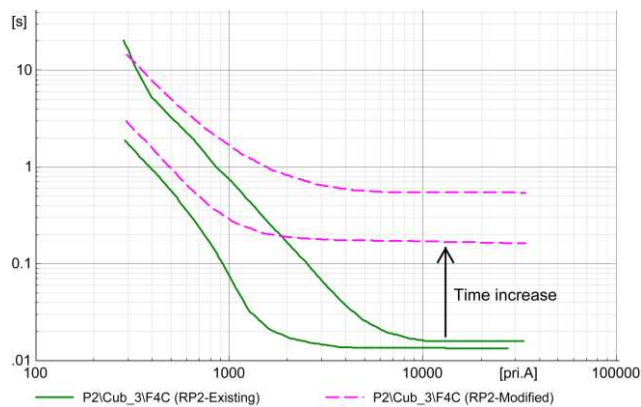

Figure 7. Existing and modified characteristics of RP2

It can be seen in Fig. 6 that the terminal voltages of DG2-DG5 recover after 53 ms from fault inception, which is the FT time delay of RP29 (depicted with the dashed-dotted vertical line in Fig. 6). However the terminal voltages of units DG1-DG4 remain below the 0.9 pu setting for 100 ms. Thus, these units will be tripped by the undervoltage element at time  $t = 1.1$  s. Obviously, this is not acceptable from the FRT point of view. According to [15], the DG units should remain connected for at least 150 ms under any voltage drop condition, which does not actually happen. In order to conform to the FRT requirements, modifications in the protection settings are proposed. Since, the undervoltage elements are the most restrictive among the DG protection elements in terms of tripping time, the resetting procedure begins from them.

The actual voltage relays installed at the power plants provide only definite-time undervoltage elements. Being aware of the current protection relay technology, we conceptualized to adjust the settings of the undervoltage elements so that they will match exactly the graph of Fig. 5. For this purpose, one definite-time undervoltage element and a rate of change of voltage magnitude ( $dv/dt$ ) element are required to replicate the graph of Fig. 5. The definite-time element will be set to trip the units in 150 ms if the voltage drop at the connection point is more than 30% of the nominal voltage magnitude ( $V < 0.7$  pu). The  $dv/dt$  element will be set with a slope equal to that shown in Fig. 5, corresponding to voltage drops between 0.1 pu - 0.3 pu. As an example, a fault that causes a 100%

voltage drop will be cleared in 150 ms, while one that causes 20% voltage drop will be cleared in 1100 ms. It is obvious that the proposed protection modification requires the existing voltage relays to be replaced with new ones.

By resetting the undervoltage elements, compliance of DG protection with the FRT requirements is achieved. Since, however, the investigation concerns a radial distribution system with reclosers, FRT requirements should be fulfilled by the reclosers as well. Therefore, new settings for the reclosers should also be proposed. In fact, the fast operation of the reclosers must be delayed to permit the operation of the DG units for as long as indicated by Fig. 5. By increasing the FT time delay, the ST time delay may also be adjusted so that coordination between the reclosers is preserved. Careful decision should be made to not increase the tripping times of the reclosers significantly. It is understood that if the FT are considerably increased, the first operation of the reclosers will not actually be so fast and the fault clearing times in the network may become prohibitive.

Based on Fig. 5, there is no need to increase the first recloser operation beyond 0.7 s - 1.5 s. Taking into account that the larger time delays correspond to smaller voltage drops, which are usually not very possible for phase faults due to the grounding method (resistively grounded secondary of the bulk HV/MV distribution transformer), time delays larger than 0.7 s are expected only for remote and/or non-solid single-phase-ground short-circuits. On the other hand, since a fuse-saving philosophy is originally followed, the increase in the tripping time of the reclosers may in some cases distort selectivity between the reclosers and the fuses at the laterals. In other words, there may be some short-circuit incidents in the laterals that will cause the blowing of a fuse prior to the operation of any recloser. However, this is a safe side compromise, which can be taken to fulfill FRT requirements in distribution systems with fuses at the laterals, unless the replacement of the fuses with overcurrent relays is available. The latter, although expensive, would provide significant advantages in the protection system [16].

The modified recloser settings are shown in Table 1. Fig. 7 shows how the modification changes the time-overcurrent characteristics of RP2.

TABLE 1. MODIFIED RECLOSER SETTINGS

P1 Phase Element		P1 Ground Element	
Curve	E2	Curve	I1
Time Dial	1	Time Dial	4
Pickup Current	400 A pr.	Pickup Current	50 A pr.
Inst. pickup	1920 A pr.	Instant. pickup	-
Open intervals	0.6-5-10 s	Open intervals	0.6-5-10 s
P2 Phase Element		P2 Ground Element	
Fast Curve	113	Fast Curve	136
Slow Curve	135	Slow Curve	142
Pickup Current	280 A pr.	Pickup Current	60 A pr.
Open intervals	0.5-5-10 s	Open intervals	0.5-5-10 s
P29 Phase Element		P29 Ground Element	
Fast Curve	117	Fast Curve	113
Slow Curve	120	Slow Curve	134
Pickup Current	140 A pr.	Pickup Current	40 A pr.
Open intervals	0.5-5-10 s	Open intervals	0.5-5-10 s

### C. Evaluation of the Modified Protection Scheme

In order to evaluate the modified protection settings, we simulated various short-circuit events. As a result of the modifications made to the DG undervoltage elements, the generators remain connected to the network for the maximum required time, according to the FRT requirements for those levels of voltage drop.

For illustrative purposes, the permanent, solid, three-phase short-circuit in front of RP29 at  $t = 1$  s is presented below. For this particular short-circuit, all DG units experience a voltage drop at the point of connection that varies between 0.15 pu and 0.52 pu. Thus, based on the modified undervoltage settings, they are disconnected after exactly 150 ms.

RP29 performs its first opening, 265 ms after the fault inception. This increase in tripping time, required for permitting the operation of the DG units for 150 ms, has been achieved by selecting a different type of inverse time characteristic (see Table 1) for the reclosers. The adjusted characteristics give a delayed trip command in comparison to the existing characteristics. Fig. 8 illustrates the complete reclosing sequence of RP29. Immediate conclusions can be drawn by comparing Fig. 3 with Fig. 8. In Fig. 3 we had a fast trip after 53 ms from the fault occurrence, while now it takes 265 ms for the breaker to trip.

Short-circuits located relatively away from the DG units may cause reduced voltage drops at the generators terminal bus and delayed tripping times of the reclosers. As an example, we simulated a double-phase-ground short-circuit with a fault resistance  $R_f = 9 \Omega$ , applied at time instant  $t = 1$  s at the beginning of line P2-P10. This fault causes RP2 to trip first after 356 ms (Fig. 9). RP29 will not pick-up for this fault (Fig. 9). If the fault is permanent, the DG units will trip after a time delay determined from the FRT characteristic, depicted in Fig. 5. If this is expected to happen after the first reclosing, the open interval time of the recloser should accordingly be adjusted to avoid this situation. Hence, the short-circuit contributions from the generators will be interrupted by the DG protection. Assume now that the fault was self-cleared during the first open interval of the recloser RP2. Then, the system would survive the disturbance and normal operation would be restored after a short supply interruption. Fig. 10 illustrates the response of the generators terminal voltages for the latter case. It can be seen that voltages restore to normal magnitudes after the first reclosing of RP2. Care should be taken to guarantee a synchronized reclosing (i.e. through synchrocheck relays).

## IV. CONCLUSIONS

It has been seen that a simple resetting of the DG and network protection relays is able to create conditions to meet the FRT requirements. On the other hand, in order to modify the protection system adequately, replacement of the voltage relays with more advanced ones is necessary.

In general, the fast operation of the reclosers must be delayed to permit the operation of the DG units for as long as indicated by the FRT requirements. This will increase the tripping time of the reclosers. Time delays larger than 0.7 s are expected only for a number of remote and/or single-phase-ground faults.

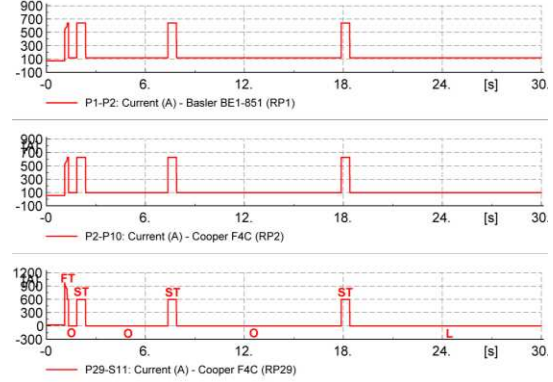

Figure 8. Reclosings due to a 3PH fault close-in to RP29

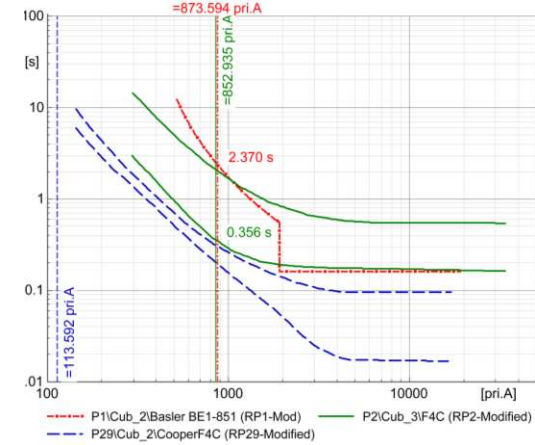

Figure 9. First trip time delays

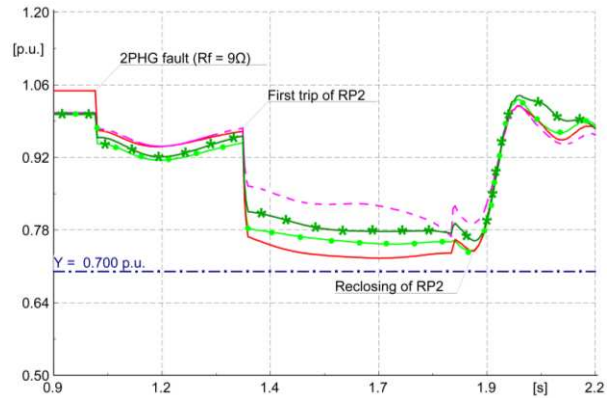

Figure 10. DG terminal bus voltage response

Selectivity is guaranteed in the MV network for all examined short-circuit types and locations. On the other hand, the increase in the tripping time of the reclosers may in some cases distort selectivity between the reclosers and the fuses at the laterals. This, however, is a safe side compromise, which can easily be faced if protection relays are to be installed instead of fuses. Then, a cost-benefit analysis is required. In the simulated cases presented in this paper, mostly permanent short-circuits have been assumed for illustrative purposes. If self-clearing or short-lasting short-circuits are considered, it is understood that DG units and the system can ride-through such disturbances, permitting the normal operation of the distribution system after the extinction of the faults.

ACKNOWLEDGMENT

The authors gratefully acknowledge the contributions of HEDNO and PPC personnel for providing all necessary data.

APPENDIX

TABLE A1. RECLOSERS TIME-OVERCURRENT SETTINGS

P1 Phase Element		P1 Ground Element	
Curve	E2	Curve	I1
Time Dial	1	Time Dial	4
Pickup Current	400 A pr.	Pickup Current	80 A pr.
Instant. pickup	1920 A pri	Instant. pickup	-
Open intervals	0.6-5-10 s	Open intervals	0.6-5-10 s
P2 Phase Element		P2 Ground Element	
Fast Curve	107	Fast Curve	132
Slow Curve	132	Slow Curve	142
Pickup Current	280 A pr.	Pickup Current	60 A pr.
Open intervals	0.5-5-10 s	Open intervals	0.5-5-10 s
P29 Phase Element		P29 Ground Element	
Fast Curve	105	Fast Curve	102
Slow Curve	112	Slow Curve	161
Pickup Current	140 A pr.	Pickup Current	40 A pr.
Open intervals	0.5-5-10 s	Open intervals	0.5-5-10 s

TABLE A2. DG PROTECTION RELAYS SETTINGS

DG1 (Vrysochori)			
Phase Element		Ground Element	
1st stage DT (I>)	1.4·In	1st stage DT (I>)	0.1·In
Time Delay (T>)	3 s	Time Delay (T>)	1.0 s
2nd stage DT (I>>)	2·In	2nd stage DT (I>>)	0.2·In
Time delay (T>>)	2 s	Time Delay (T>>)	0.5 s
3rd stage DT (I>>>)	10·In	3rd stage DT (I>>>)	-
Time Delay (T>>>)	0.05 s	Time Delay (T>>>)	-
Voltage Element		Frequency Element	
Undervoltage (U<)	0.9 pu	Underfrequency (f<)	49.5Hz
Time Delay (T<)	0.1 s	Time Delay (T<)	0.1 s
Overvoltage (U>)	1.11pu	Overfrequency (f>)	50.5Hz
Time Delay (T>)	0.1 s	Time Delay (T>)	0.1 s
Residual Voltage Element			
1st stage (3Vo>)	15 V	Time Delay (T>)	4 s
DG2 and DG3 (Perivoli)			
Phase Element		Ground Element	
1st stage DT (I>)	1.2·In	1st stage DT (I>)	0.2·In
Time Delay (T>)	2 s	Time Delay (T>)	0.5 s
2nd stage DT (I>>)	1.4·In	2nd stage DT (I>>)	0.4·In
Time delay (T>>)	1 s	Time Delay (T>>)	0.1 s
Voltage Element		Frequency Element	
Undervoltage (U<)	0.92 pu	Underfrequency (f<)	49.5Hz
Time Delay (T<)	0.1 s	Time Delay (T<)	0.1 s
Overvoltage (U>)	1.08 pu	Overfrequency (f>)	50.5Hz
Time Delay (T>)	0.1 s	Time Delay (T>)	0.1 s
Residual Voltage Element			
1st stage (3Vo>)	15 V	2nd stage (3Vo>>)	20 V
Time Delay (T>)	3 s	Time Delay (T>>)	2 s
DG4 (Distrato) – DG5 (Alatopetra)			
Phase Element		Ground Element	
1st stage DT (I>)	0.8·In	1st stage DT (I>)	0.1·In
Time Delay (T>)	2 s	Time Delay (T>)	0.5 s
2nd stage DT (I>>)	1.4·In	2nd stage DT (I>>)	0.4·In
Time delay (T>>)	1 s	Time Delay (T>>)	0.1 s
3rd stage DT (I>>>)	1.7·In	3rd stage DT (I>>>)	-
Time Delay (T>>>)	0.1 s	Time Delay (T>>>)	-

Voltage Element		Frequency Element	
Undervoltage (U<)	0.92pu	Underfrequency (f<)	49.5 z
Time Delay (T<)	0.1 s	Time Delay (T<)	0.5 s
Overvoltage (U>)	1.08pu	Overfrequency (f>)	50.5Hz
Time Delay (T>)	0.1 s	Time Delay (T>)	0.5 s
Residual Voltage Element			
1st stage (3Vo>)	20 V	Time Delay (T>)	5 s

REFERENCES

- [1] P. M. Anderson, *Power System Protection*. NY: Wiley-IEEE Press, 1998.
- [2] M. H. Bollen and F. Hassan, *Integration of Distributed Generation in the Power System*. New York: Wiley-IEEE Press, 2011.
- [3] S. P. Chowdhury, S. Chowdhury, and P. A. Crossley, "Islanding protection of active distribution networks with renewable distributed generators: A comprehensive survey," *Electric Power Systems Research*, vol. 79, pp. 984–992, 2009.
- [4] S. M. Brahma and A. A. Girgis, "Microprocessor-based reclosing to coordinate fuse and recloser in a system with high penetration of distributed generation", in *Proc. 2002 IEEE PES Winter Meeting Conf.*, pp. 1–5.
- [5] A. Zamani, T. Sidhu, and A. Yazdani, "A strategy for protection coordination in radial distribution networks with distributed generators", in *Proc. 2010 IEEE PES General Meeting Conf.*, pp. 1-8.
- [6] S. M. Brahma and A. A. Girgis, "Development of adaptive protection scheme for distribution systems with high penetration of distribution generation", *IEEE Trans. Power Delivery*, vol. 19, pp. 56-63, 2004.
- [7] H. B. Funmilayo and K. L. Butler-Purry, "An approach to mitigate the impact of distributed generation on the overcurrent protection scheme for radial feeders," in *Proc. 2009 IEEE/PES Power Systems Conference and Exposition*, pp. 1-11.
- [8] V. Calderaro, J. Milanovic, M. Kayikci, A. Piccolo.: 'The impact of distributed synchronous generators on quality of electricity supply and transient stability of real distribution network', *Electric Power Systems Research*, 79, pp. 134–143, 2009.
- [9] M. Dewadasa, A.Ghosh, and G. Ledwich, "Protection of distributed generation connected networks with coordination of overcurrent relays," in *Proc. 2011 Annual Conference of the IEEE Industrial Electronics Society (37th IECON)*, pp. 924 – 929.
- [10] V. Nikolaidis, A. Karaolanis, T. Papadopoulos, A. Safigianni, "Transient Stability Considerations in a Real Distribution System with Distributed Generators", in *Proc. 2016 Mediterranean Conference on Power Generation, Transmission, Distribution and Energy Conversion (10th MEDPOWER)*.
- [11] D. Popovic and I. Wallace, "International Review of Fault Ride Through for Conventional Generators," KEMA, 2010.
- [12] *IEEE Draft Standard for Interconnection and Interoperability of Distributed Energy Resources with Associated Electric Power Systems Interfaces*, IEEE Std 1547 revision, in progress.
- [13] EDSO for Smart Grids, "Establishment of annual priority lists for the development of network codes and guidelines for 2015 and beyond", EDSO response to European Commission public consultation, in progress.
- [14] ENTSO-E, "Network Code for Requirements for Grid Connection - Applicable to all Generators," 2013.
- [15] Bundesverband der Energie und Wasserwirtschaft (BDEW), "Technical Guideline – Generating Plants Connected to the Medium-Voltage Network," June 2008.
- [16] V. C. Nikolaidis, E. Papanikolaou, and A. S. Safigianni, "A Communication-Assisted Overcurrent Protection Scheme for Radial Distribution Systems With Distributed Generation", *IEEE Trans .Smart Grid*, vol. 7, pp. 114-123.