



Deposited via The University of Sheffield.

White Rose Research Online URL for this paper:

<https://eprints.whiterose.ac.uk/id/eprint/108113/>

Version: Accepted Version

Article:

Zhang, L, Lang, Z and Papaalias, M (2016) Generalized Transmissibility Damage Indicator with Application to Wind Turbine Component Condition Monitoring. IEEE Transactions on Industrial Electronics, 63 (10). pp. 6347-6359. ISSN: 0278-0046

<https://doi.org/10.1109/TIE.2016.2580519>

© 2016 IEEE. Personal use of this material is permitted. Permission from IEEE must be obtained for all other users, including reprinting/ republishing this material for advertising or promotional purposes, creating new collective works for resale or redistribution to servers or lists, or reuse of any copyrighted components of this work in other works.

Reuse

Items deposited in White Rose Research Online are protected by copyright, with all rights reserved unless indicated otherwise. They may be downloaded and/or printed for private study, or other acts as permitted by national copyright laws. The publisher or other rights holders may allow further reproduction and re-use of the full text version. This is indicated by the licence information on the White Rose Research Online record for the item.

Takedown

If you consider content in White Rose Research Online to be in breach of UK law, please notify us by emailing eprints@whiterose.ac.uk including the URL of the record and the reason for the withdrawal request.

Generalized Transmissibility Damage Indicator with Application to Wind Turbine Component Condition Monitoring

Long Zhang, *Member, IEEE*, Zi-Qiang Lang, Mayorkinos Papaalias

Abstract—Frequency methods such as frequency spectrum analysis, frequency spike detection, demodulation, envelope spectrum method have been widely used for condition monitoring of engineering structural systems. Different from the conventional frequency methods, the transmissibility function (TF) represents the relationship between different system output responses such as, e.g. vibration and acoustic emission sensor measurements. This paper introduces a simple and effective generalized transmissibility damage indicator (GTDI) for TF based condition monitoring. Unlike the conventional transmissibility damage indicator (TDI), the new GTDI can improve the detection sensitivity, reduces noise effects and avoid dynamic loadings effects. This is achieved by combining multiple groups of data to obtain more accurate transmissibility analysis, exploiting all the available TFs, and using multiple references. This has two advantages. First, it does not require any other priori knowledge about the system responses. Therefore the method can be used for the condition monitoring of a wide range of components or systems. Further, the method can be easily implemented using Fast Fourier transform (FFT) or power spectra density (PSD) methods and therefore is computationally efficient. These make the method very suitable for implementing online real-time condition monitoring. The method is investigated by simulation studies and then applied to analyze the vibration data of the main bearing of operating wind turbines, producing very promising results.

Index Terms—Frequency methods, Transmissibility function, Damage Indicator, Condition monitoring, Wind turbines

I. INTRODUCTION

Fault detection plays an important role in all engineering systems. Early and timely fault finding can effectively avoid further deterioration and catastrophic failure [1]. Traditional periodic inspections using empirical and subjective reargument are not economically effective or efficient as they often require undesired downtime and can not fully evaluate the system conditions [2]. To remedy the drawback of periodic inspections, condition or health monitoring systems have been developed and applied to monitor vulnerable components. Such systems can provide early warnings of both mechanical and electrical faults without affecting their functionalities [3].

Frequency analysis methods are the most popular condition monitoring methods as many faults, such as unbalance and crack in mechanical components and structures, can result in

the changes in the frequency components of sensor measurements. Typical frequency methods include spectrum analysis, frequency spike detection and envelope method [4]. If the measured data are corrupted by the strong noise or transient signal from a complex component, filter methods, such as adaptive noise cancelation, are often used to remove the noise [5], [6], [7]. For rotating machine condition monitoring, the demodulation methods are widely used. The objective of demodulation is to suppress the resonant or carrier frequencies of the rotating machine and then highlight its sidebands [4]. A mechanical fault or damage can produce new sidebands or cause changes in the existing sideband components. Envelope analysis is one of amplitude demodulation methods. However, for both demodulation and envelope analysis, the filtering bands have to be carefully chosen, otherwise the useful component spectrum can be removed [8].

A main challenge in condition monitoring is that many systems are under non-stationary operations with dynamic loading [7]. For example, wind turbines work under time-varying wind loads. The non-stationary loads may produce different frequency spectra and cause the difficulties in distinguishing damaged from healthy conditions [6]. A common approach for removing the loading effects is to build the relationship between extracted condition monitoring features and corresponding loading conditions. A linear relationship is often used due to its simplicity and computational efficiency [6]. If the linear model is not satisfactory in term of detection performance, the nonlinear artificial intelligent (AI) methods have to be used. However, the nonlinear AI methods often require a complex optimization process for parameter estimation, which is often computationally demanding. Another approach for removing the loading effects is to re-scale the original condition data or features under non-stationary loading conditions to those under a standard load condition. For the scaling operations, many un-supervising methods, such as principal component analysis and canonical discriminant analysis are used [7], [9].

Alternatively, frequency response function (FRF), which is also referred to as transfer function, and defined as the ratio of the complex spectrum of the output response with respect to the complex input spectrum, can represent system inherent properties and can therefore be used for condition monitoring. Here, the system input is also equal to the system load mentioned in the previous paragraph. If system inputs are unknown or hard to measure, the FRF can not be used. Recently, transmissibility function (TF), which is also referred to as transmittance function [10], [11], has been used to

L. Zhang and Z. Q. Lang are with the Department of Automatic Control and Systems Engineering, The University of Sheffield, Sheffield, UK, S1 3JD, e-mails: zhanglonghit@gmail.com and z.lang@sheffield.ac.uk. M. Papaalias is with School of Metallurgy and Materials, The University of Birmingham, Birmingham, B15 2TT, UK, e-mail: m.papaalias@bham.ac.uk

represent the relations among the system outputs. The TF can be easily computed using only measured system outputs. In theory, TF has been derived using the dynamic properties of the system structure for multiple degree of freedom (MDOF) systems [12], [13], [10], and for MDOF structure system, TF is solely dependent on system zeros while FRF are dependent on not only system zeros but also system poles. Since system zeros tend to be sensitive to local damage, TF can be a indicator of damage or changes in structural properties [14], [15].

A critical issue using TF for damage detection is to choose a criterion reflecting the changes of TF. Several criteria are available. The integration of the differences between healthy and in-service TFs was proposed in [10]. Later, a logarithm was used for TF before the integration is carried out [16]. For these two indicators, if the integral value is above a predefined threshold, it indicates that damage is present. The methods are easy to implement if a system has only two sensor measurements so only one threshold is needed. However, for multiple-sensor measurements, there are multiple TFs, and it is difficult to determine multiple thresholds [15]. Alternatively, novelty or outlier detection methods, such as Mahalanobis squared distance method, auto-associative networks and kernel density estimation, can also be used to distinguish the normal TFs and the abnormal ones [17], [15].

More recently, a new transmissibility damage indicator (TDI) is proposed in [18], where the correlation between healthy and in-service TFs is used to estimate the structural working conditions. Compared to the aforementioned integral criteria, TDI is capable to deal with multiple TFs as it has only one threshold for any number of TFs. Different from neural networks or density estimation methods, TDI does not involve complex training process. However, it is found in this study that TDI may not be suitable for online condition monitoring as it may not be able to obtain accurate signal frequency components using only one data collection. Further, it does not fully utilize the potentials of TFs because only adjacent TFs are used and non-adjacent TFs are not used. Finally, TDI may not be able to reduce noise effects on TFs based analysis. In order to fully exploit the potentials of TFs, this paper proposes a generalized transmissibility damage indicator (GTDI) that extends TDI to a more general case. GTDI groups together multiple collections of data to obtain more accurate TF analysis results. GTDI also uses the TFs between all different outputs, leading to an improved detection accuracy. Moreover, multiple references and in-service TFs are used to more effectively remove noise effects, to take different loading effects into account, and to enable using only one TF to conduct condition monitoring, which can not be achieved if TDI is applied. Both simulation studies and the analysis of vibration data from an operating wind turbine have been conducted. The results have verified the effectiveness of the GTDI based TF analysis and demonstrated the potential to apply the new technique in wind turbine component or system condition monitoring.

II. TRANSMISSIBILITY DAMAGE INDICATOR (TDI)

This section will introduce the concept of TF and the formulation of conventional TDI, followed by some discussions on the problems with the TDI based analysis. The TF is defined as the ratio of spectra of two different output measurements. Therefore the spectra have to be obtained first. Suppose there are M system output responses measured by sensors. The N point discrete spectra of these responses are given by $F=[X_1, \dots, X_i, \dots, X_M]$, where

$$X_i^T = [x_{i1}e^{-jw_1}, \dots, x_{ir}e^{-jw_r}, \dots, x_{iN}e^{-jw_N}] \\ = [x_{i1}(w_1), \dots, x_{ir}(w_r), \dots, x_{iN}(w_N)] \quad (1)$$

with x_{ir} being a complex number, representing both the amplitude and phase of the i th measurement at frequency w_r , $r = 1, \dots, N$, $i = 1, \dots, M$.

The conventional transmissibility function used by TDI is defined as the spectra ratio between two adjacent responses. Let i and $(i+1)$ denote the two adjacent measurement indexes, where $i = 1, \dots, M-1$, and denote the transmissibility function for two neighboring measurements as

$$T_{i(i+1)} = [t_{i(i+1)}(w_1), \dots, t_{i(i+1)}(w_r), \dots, t_{i(i+1)}(w_N)] \quad (2)$$

where

$$t_{i(i+1)}(w_r) = \frac{x_{ir}(w_r)}{x_{(i+1)r}(w_r)} = \frac{x_{ir}e^{-jw_r}}{x_{(i+1)r}e^{-jw_r}} = \frac{x_{ir}}{x_{(i+1)r}} \quad (3)$$

The total number of such transmissibility functions is $L = (M-1)$. To simplify the expression of $t_{i(i+1)}(w_r)$, denote

$$\{t_{i(i+1)}(w_r), i = 1, \dots, M-1\} = \{\tau_l(w_r), l = 1, \dots, L\} \quad (4)$$

Then the spectra of all the transmissibility functions can be written as

$$\Gamma = \begin{bmatrix} \tau_1(w_1) & \tau_1(w_2) & \dots & \tau_1(w_N) \\ \tau_2(w_1) & \tau_2(w_2) & \dots & \tau_2(w_N) \\ \vdots & \vdots & \vdots & \vdots \\ \tau_L(w_1) & \tau_L(w_2) & \dots & \tau_L(w_N) \end{bmatrix} \quad (5)$$

For damage detection and condition monitoring purpose, the correlation between the reference and in-service transmissibility functions at frequency w_r , denoted by ${}^h\tau(w_r)$ and $\tau(w_r)$, respectively, is defined as follows

$$TC(w_r) = \frac{|\sum_{l=1}^L \tau_l(w_r) {}^h\bar{\tau}_l(w_r)|^2}{[\sum_{l=1}^L \tau_l(w_r) \bar{\tau}_l(w_r)][\sum_{l=1}^L {}^h\tau_l(w_r) {}^h\bar{\tau}_l(w_r)]} \quad (6)$$

where the upper bar represents the conjugate operator. TDI is the average of $TC(w_r)$ at all the considered discrete frequencies w_1, \dots, w_N , which is given by

$$TDI = \frac{1}{N} \sum_{r=1}^N TC(w_r) \quad (7)$$

and has many advantages. First, TDI is a model-free method, and therefore it does not involve any analytic or numerical modeling process. Second, it is demonstrated that it is more sensitive to the changes in the system properties than FRF based method [18]. Finally, it is a simple and efficient method as main computations can be implemented using the FFT algorithm.

In [18], the impact of positions of system input on TDI was also considered, indicating that $\tau_l(w_r)$ varies with the position of system input. Therefore, $\tau_l(w_r)$ can be denoted as $\tau_l(w_r, q)$ where q indicates that the input was applied at the q th position. Consequently, an extension of equation Equ. (6) to the case where the input can respectively be applied in M different positions is given by

$$TC(w_r)' = \frac{|\sum_{q=1}^M \sum_{l=1}^L \tau_l(w_r, q)^h \bar{\tau}_l(w_r, q)|^2}{SS[\tau_l(w_r, q)]SS[h\bar{\tau}_l(w_r, q)]} \quad (8)$$

where $SS[\tau_l(w_r, q)] = [\sum_{q=1}^M \sum_{l=1}^L \tau_l(w_r, q) \bar{\tau}_l(w_r, q)]$ and $SS[h\bar{\tau}_l(w_r, q)] = [\sum_{q=1}^M \sum_{l=1}^L h\bar{\tau}_l(w_r, q) \tau_l(w_r, q)]$, and the corresponding TDI becomes

$$TDI' = \frac{1}{N} \sum_{r=1}^N TC(w_r)' \quad (9)$$

However, it is worth pointing out the position of system input can not be controlled in most practical situations. In general, TDI is suitable for a wide range of situations. Although used in many real-world applications, the concept has the following four aspects of problems:

- TDI may not be suitable for online or operational condition monitoring. The reasons are as follows. The first task of TDI is to compute the discrete spectra as shown in Equ. (1). TDI requires that reference and in-service data have the same frequency components over the range of frequencies from w_1 to w_N . This can be satisfied when the frequencies of input excitation can be designed or controlled. However, for online or operational condition monitoring, the input often varies and may have different frequency components over different time periods, which may cause the difficulty in conducting accurate TF analysis. This is because one data collection only lasts for a certain time and may not necessarily cover all the required frequency range. Therefore, the resultant reference and in-service TFs may not be able to be used to fully evaluate the system conditions.
- TDI does not fully utilise the potentials of TFs because only adjacent measurements are used and non-adjacent measurements are not used. In other words, TDI does not use all the available TFs. If all the TFs are used, the accuracy of damage detection could be improved. Here we simply stress the importance of exploiting the contributions of all the TFs rather than just a few TFs as in the case of traditional TDI method. For example, suppose there are three measurements, say s_1, s_2, s_3 . The transmissibility function between s_1 and s_2 is denoted as T_{12} while the transmissibility function between s_2 and s_3 is written as T_{23} . TDI only uses the T_{12} and T_{23} without consideration of using T_{13} related to the s_1 and s_3 . As some changes in system properties that can be detected by T_{13} may not be found by T_{12} or T_{23} [14], [19], the conventional TDI may miss some significant changes in system properties. In other words, TDI only employs the local information represented by adjacent sensor data while some global information can be missed.

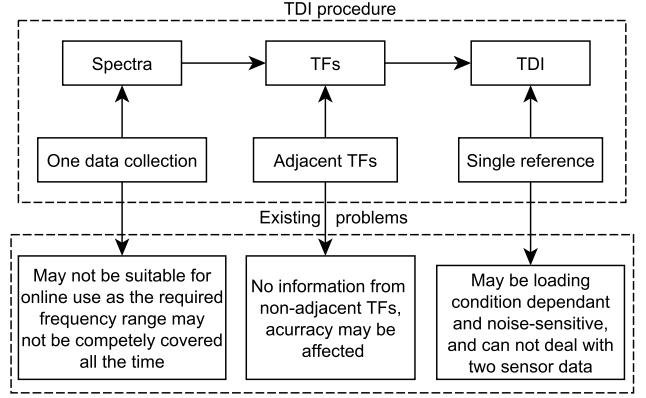

Fig. 1. The TDI procedure and its drawbacks

Further, as some of these changes may need to be detected by more than one TF, the more TFs are used, the easier these changes can be detected.

- As defined in Equ. (7), TDI is the average of transmissibility correlations between reference and in-service TFs over all frequencies. The information can be affected by noise. The TDI technique does not consider using noise elimination methods to obtain a more accurate spectra. Further, TDI only uses one reference represented by the TFs evaluated under a normal system operating condition. If the reference is not chosen well, the corresponding TDI results may have problems and can not be used for the required condition monitoring purposes.
- It is also found that TDI can not deal with the case where only two measurements are available as the value of TDI in this case is always equal to 1. This problem can be explained as follows. For a given frequency $w_r, r = 1, \dots, N$, suppose reference TF $h\bar{\tau}_1(w_r) = a + bj$ and in-service TF $h\bar{\tau}_1(w_r) = c + dj$, where a, c are the real parts and b, d are the imaginary parts of the complex numbers, respectively,

$$TC(w_r) = \frac{|(a + bj)(c - dj)|^2}{[(a + bj)(a - bj)][(c + dj)(c - dj)]} \quad (10)$$

$$= \frac{(ac)^2 + (ad)^2 + (bc)^2 + (bd)^2}{(ac)^2 + (ad)^2 + (bc)^2 + (bd)^2} = 1$$

Consequently, $TDI = \frac{1}{N} \sum_{r=1}^N TC(w_r) = 1$ all the time, indicating TDI cannot be used in this case.

Fig. 1 summarizes the procedure of the TDI based analysis and its drawbacks. To address these problems, a new concept known as generalized TDI (GTDI) is proposed in next section.

III. GENERALIZED TRANSMISSIBILITY DAMAGE INDICATOR (GTDI)

To address the problems of TDI discussed in the previous section, GTDI is proposed in the present study. The associated analysis first merges multiple collections of data to cover the

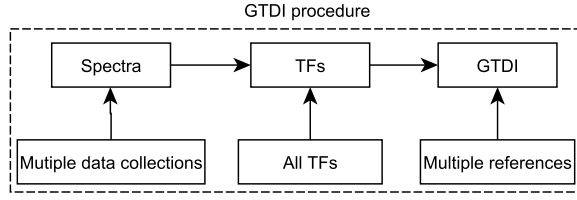

Fig. 2. The GTDI procedure

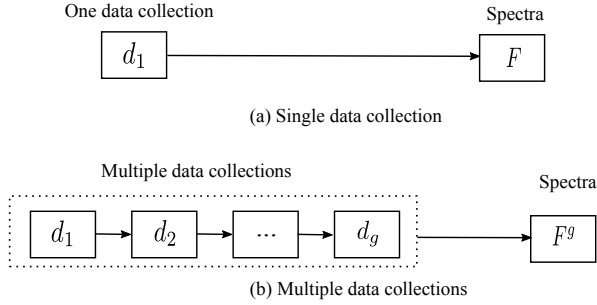

Fig. 3. Merging multiple samplings

full range of working frequencies of the system. Further, it uses all possible TFs in order to exploit all the information in the data. Finally, it uses multiple reference and in-service TFs to mitigate the effects of noises and different loading conditions. The general procedure of the GTDI based analysis is shown in Fig. 2.

The first step is to merge multiple collections of data in order to obtain full range of data spectra. In most practical cases, the length of data in each collection is determined by expert experience and not optimal. Therefore, the information in a single collection may not fully represent the system conditions. In other words, the data from a single collection may not contain all frequency components needed for the condition monitoring. Further, under dynamic loading conditions, it is even harder to estimate the signal frequency components only from a single collection of data due to time varying nature of loading input. Finally, noise in the data can also increase the difficulty of conducting data frequency analysis. To address these problems, merging multiple collections of data is proposed. For example, if the each collection has 1000 data points and 3 collections are grouped together, the emerged data has 3000 data points. Suppose the g collections, denoted as d_1, d_2, \dots, d_g , are merged together, the spectra of these grouped data are given by $F^g = [X_1^g, \dots, X_i^g, \dots, X_M^g]$, where

$$X_i^{gT} = [x_{i1}^g e^{-jw_1}, \dots, x_{ir}^g e^{-jw_r}, \dots, x_{iN}^g e^{-jw_N}] \\ = [x_{i1}^g(w_1), \dots, x_{ir}^g(w_r), \dots, x_{iN}^g(w_N)] \quad (11)$$

with x_{ir}^g being a complex number, representing both the amplitude and phase of the i th measurement at frequency w_r , $i = 1, \dots, M$. A comparison between single and multiple data collections is shown in Fig. 3.

It is also worthwhile mentioning that if both amplitude and phase information are equally important to represent the dynamic behaviors of the system, FFT is the most useful tool

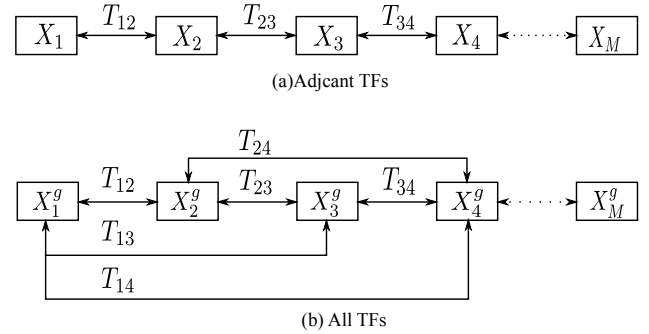

Fig. 4. Adjacent TFs and all TFs

to obtain the information. If amplitudes are more significant than phases in terms of presenting the changes in the system properties or the phases are hard to be estimated accurately due to noise, phases can be ignored. In this case, power spectra density (PSD) methods, like the welch algorithm [20], is preferable to compute amplitude only information.

In the second step, all available TFs are formulated by using all the combinations of two different responses. More specifically, TF between i th and k th responses is defined as their spectra ratio, that is

$$T_{ik} = [t_{ik}(w_1), \dots, t_{ik}(w_r), \dots, t_{ik}(w_N)] \quad (12)$$

where

$$t_{ik}(w_r) = \frac{x_{ir}^g(w_r)}{x_{kr}^g(w_r)} = \frac{x_{ir}^g e^{-jw_r}}{x_{kr}^g e^{-jw_r}} = \frac{x_{ir}^g}{x_{kr}^g} \quad (13)$$

and $i = 1, \dots, M-1, k = i+1, \dots, M$. To make the expression $t_{ik}(w_r)$ simpler, the two index variables i, k are again rewritten as one single vector, which is shown as follows:

$$\{t_{ik}(w_r), i = 1, \dots, M-1, k = i+1, \dots, M\} \\ = \{\tau_l(w_r), l = 1, \dots, L\} = \Gamma \quad (14)$$

Fig. 4 is used to show the differences between adjacent TFs and all TFs. The conventional TDI only exploits the adjacent TFs, more specifically, only $T_{i(i+1)}, i = 1, \dots, M-1$ are used. For M sensor measurements, TDI exploits $(M-1)$ TFs. However, GTDI exploits all the possible combinations up to $M(M-1)/2$ and thus fully exploits the potential damage information. Further, the larger sensor number is, the more TFs will be used by GTDI than by TDI. Although GTDI uses more TFs than TDI, its main computational demand is almost the same as that of TDI since their main computations come from the calculation of data spectra. Specifically speaking, for M sensor data, M spectra calculation is needed, which counts on the majority of the computations since other calculations, including ratios and correlation, are negligible. Due to the fact that spectra analysis can be easily implemented on both a computer and micro-controller, GTDI is suitable for online real-time condition monitoring.

The third improvement made in the present study is to use multiple references. The reference TFs often represent the healthy system conditions. However, it is often hard to determine an optimal reference due to noise effects. To overcome the problem, the multiple references provide a

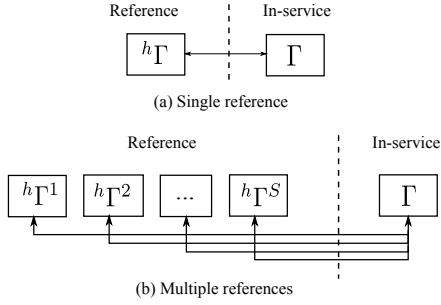

Fig. 5. Single reference and multiple reference

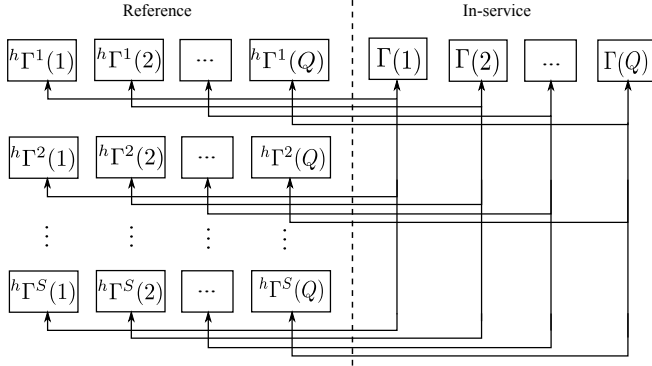

Fig. 6. Multiple in-service TFs and multiple references

feasible solution. As compared to the single reference, multiple references can be more noise-robust. This is because multiple references are able to introduce an averaging effects, leading to an improved accuracy of analysis. Fig. 5 shows the difference between the single and multiple references.

In addition to noise, the effects of dynamic loading also have to be considered when estimating the in-service TFs. Therefore, the multiple data sets scheme is also used for in-service data in the proposed GTDI method. The multiple in-service data sets was considered in TDI, as shown in Equ. (8). However, it was only used for possible changes in input positions. This study proposes that the multiple in-service TFs can be used in any situations if necessary. Fig. 6 shows how to use the multiple in-service TFs and multiple references simultaneously. For the two sensor data case, there is only one TF, and TDI can not be used, which has been explained in the previous section. However, GTDI can address this problem by using multiple in-service TFs where $Q \geq 2$. This can be easily explained using the same procedure as shown in Equ. (10).

A detailed mathematical description of multiple in-service TFs and references based GTDI method is given as follows. Suppose the number of multiple operations used for evaluating the in-service TFs is Q , TFs can be written as

$$\Gamma(q) = \begin{bmatrix} \tau_1(w_1, q) & \tau_1(w_2, q) & \dots & \tau_1(w_N, q) \\ \tau_2(w_1, q) & \tau_2(w_2, q) & \dots & \tau_2(w_N, q) \\ \vdots & \vdots & \ddots & \vdots \\ \tau_L(w_1, q) & \tau_L(w_2, q) & \dots & \tau_L(w_N, q) \end{bmatrix} \quad (15)$$

Denote the number of multiple references as S . Then the correlations between s th reference TFs and all the in-service

TFs can be obtained as

$$MTC(w_r, s) = \frac{|\sum_{l=1}^L \sum_{q=1}^Q \tau_l(w_r, q) \bar{\tau}_l^s(w_r, q)|^2}{SS[\tau_l(w_r, q)]SS[h\bar{\tau}_l^s(w_r, q)]} \quad (16)$$

$SS[\tau_l(w_r, q)] = \sum_{q=1}^Q \sum_{l=1}^L \tau_l(w_r, q) \bar{\tau}_l(w_r, q)$ and $SS[h\bar{\tau}_l^s(w_r, q)] = \sum_{q=1}^Q \sum_{l=1}^L h\bar{\tau}_l^s(w_r, q) \bar{\tau}_l^s(w_r, q)$. Finally, the proposed GTDI is given by

$$GTDI = \frac{1}{S} \frac{1}{N} \sum_{s=1}^S \sum_{r=1}^N MTC(w_r, s) \quad (17)$$

The properties of the new GTDI concept are summarized as follows:

- 1) As GTDI represents the correlation between the reference and in-service conditions, its range is $[0, 1]$.
- 2) If in-service condition is highly correlated with the reference conditions, GTDI approaches 1 and this implies the in-service condition is good. In practice, due to the noise, even if a condition is almost the same as the reference cases, GTDI could not be exactly 1 but near 1.
- 3) As GTDI is sensitive to damage, there are clear differences between healthy state references and damage cases. Further, the smaller GTDI is, the severer the damage can be. Therefore, GTDI values can show the levels of damage severity.

The procedure of condition monitoring using GTDI method is simple and can be summarized as follows:

Step 1: Compute data spectra shown in Eqn. (1) using FFT or PSD method.

Step 2: Calculate the TFs using Equ. (12).

Step 3: Compute GTDI using Equ. (17).

It is important to point out that the choice for the number of repetitive data collections and the number of multiple reference and in-service TFs are not trivial tasks. The principal is to start without repetition, namely $g = 1, Q = 1, S = 1$. If the GTDI results are smooth, the repetition is not necessary as the impact of the noise and dynamic loading is quite small. If GTDI results fluctuate, then the repetition number can be increased gradually until smooth results are obtained. As the number of multiple data collections g controls the spectra accuracy in Step 1, it is more important than multiple reference and in-service TFs in Step 3. It is therefore suggested to increase g first until the smoothness in the results does not increase any more. Then, if necessary, increase S and Q in the same way to further improve the analysis results.

IV. DISCUSSIONS

TF is an important and promising concept and can be used in many applications. However, in the literature [15], [21], it has been pointed that several important issues, such as the frequency range and the location of input, have to be considered first. In this section, detailed discussions on these issues are given as below.

Frequency range: The frequency range plays an important role in condition monitoring. A carefully chosen frequency range can improve the detection accuracy. In [21], it has been shown that damage in a cantilever beam can be more

accurately detected using a small frequency band around resonance frequencies of the structure than that using the whole frequency range. However, in many practical applications, it is hard to determine a specific frequency band without knowing the frequency responses of all possible damage or faults. As GTDI does not restrict the frequency range, it can be used over either a user chosen frequency range or the full frequency range.

The location of the excitation source: It is also a key factor that has to be considered when using TF based condition monitoring. The reason for this is that the TF is dependent on the location of applied input although there are some exceptions [15]. In other words, for the same healthy condition, TFs may be different if the excitation is applied at two different locations. If the excitation location can be designed, the simple option is to apply the excitation at a single input position and make sure the system is excited at the same location for all the whole inspection period. As GTDI can use the multiple TFs, the inspected system can have several input locations. But the system inputs have to be applied at a predefined order over the inspection period to make sure each reference and in-service TF are compared under the same loading condition. When multiple locations of input are considered, the input can either be applied to the multiple locations one by one or on these locations simultaneously. However, it is worth pointing out that if the applied inputs are randomly applied to different locations of inspected systems, all the TF based condition monitoring methods including GTDI may not be used.

The nature of monitored system: The system nature needs to be considered when conducting condition monitoring using GTDI method. In the present study, the linear non-dispersive system that can be described by a MDOF system is considered, which can readily be studied by a simple numerical simulation. The application of the GTDI method to such a system is to demonstrate the effectiveness of the new method in a simple case so as to show that the fundamental principle of the GTDI method is correct. The real engineering systems are inherently dispersive having a very high degree of freedoms. Therefore, the study also applied the proposed method to a practical system to demonstrate that the new method also works well in the more complicated dispersive system case. Further, as TF represents the system physical properties, it can be used in both structure health monitoring [22] and rational system condition monitoring [23]. If the monitored system can be simplified to be a linear time-invariant system, GTDI can deal with such systems well as all the physical parameters are not changed with time and they can produce an unique TF. If the system is time-varying, which can be caused by a variety of reasons, such as environment and varying loadings, GTDI can still be used in such cases as GTDI can use different TFs to cover different cases of a system due to the time varying nature of the system parameters.

Measurement types: Although TF is most widely known for vibration data analysis, TF can use a variety of measurements, including, e.g. motor current. The reasons are shown as follows. TF is the ratio between the spectra of two different responses, and TF is also equal to the ratio of two different FRF or transfer functions. Therefore, as long as

the measurement is related to the system dynamic behaviour under some excitations, it can be used in a TF based condition monitoring method, including the proposed GTDI method.

Applications: The proposed GTDI is a general condition monitoring method and it can be used for both structural health monitoring, such as bridge, turbine blade and turbine tower, and rotating machine monitoring such as gearbox, bearing and generator. GTDI method can not only detect a fault but also indicate the damage severity levels. However, GTDI is not designed for diagnosing a fault and therefore it can not show the reasons which induce faults.

References: In practice, the baseline states which are not normal but have only smaller defects can still be used. In this case, the proposed GTDI can use the measured data representing small defects as the reference and then indicate whether there is a further deterioration causing severe defects. The reason for this is that GTDI evaluates the similarity between reference and in-service case using correlations of TFs and can therefore detect changes caused by further deterioration.

Advantages and limitations: The advantages of GTDI over existing methods are summarized here. Compared to model based methods in which the loading information needs to be measured to remove the effects of non-stationary loads, GTDI does not require any loading information but can eliminate the effects of varying loadings. Therefore, GTDI provides a cost effective way for condition monitoring without additional hardware for collecting loading information. Further, GTDI can use the system responses over the whole frequency range while most model based methods only use extracted frequency features. If the extracted feature is not well chosen, it may not fully reflect the real system conditions and cause false alarms. Finally, many nonlinear AI methods are not computationally efficient and may not be suitable for the on-line condition monitoring while GTDI can be used for online condition monitoring due to its low computation demands. GTDI can be used for a variety of applications even if the input scenario can not be fixed. However, as mentioned previously, GTDI may not be applicable if the excitations are randomly applied at the different locations of an inspected system; this is the main limitation of the proposed method.

V. NUMERICAL EXAMPLE

To evaluate the performance of the proposed GTDI method, a numerical study for a MDOF system condition monitoring problem is carried out using MATLAB R2013b on a desktop Intel PC with Windows 7 system. It is worth pointing that as the proposed method is a general condition monitoring method, it can be used for both structure health monitoring and rotating machine condition monitoring. Therefore, a general MDOF model, rather than a specific model, is used to test the performance of the new method. The MDOF system can be described as

$$\mathbf{M}\ddot{\mathbf{x}} + \mathbf{C}\dot{\mathbf{x}} + \mathbf{K}\mathbf{x} = \mathbf{F} \quad (18)$$

where the applied force \mathbf{F} is the system input vector and displacement \mathbf{x} is the system output vector, and

$$\mathbf{M} = \text{Diag}(m_1, m_2, \dots, m_n) \quad (19)$$

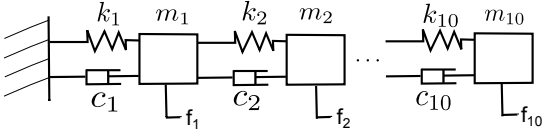

Fig. 7. 10 DOF system used in the numerical simulation

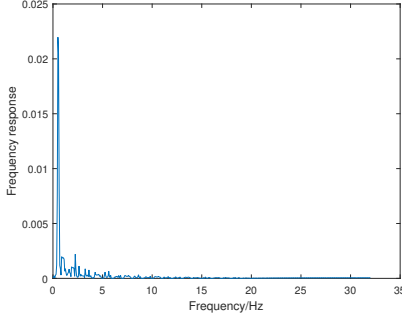

Fig. 8. The frequency response of the 1st coordinate

$$\mathbf{C} = \begin{bmatrix} c_1 + c_2 & -c_2 & 0 & 0 & \dots & 0 \\ 0 & -c_2 & c_2 + c_3 & -c_3 & \dots & 0 \\ \vdots & \vdots & \vdots & \vdots & \vdots & \vdots \\ 0 & 0 & 0 & \dots & -c_n & c_n \end{bmatrix} \quad (20)$$

$$\mathbf{K} = \begin{bmatrix} k_1 + k_2 & -k_2 & 0 & 0 & \dots & 0 \\ 0 & -k_2 & k_2 + k_3 & -k_3 & \dots & 0 \\ \vdots & \vdots & \vdots & \vdots & \vdots & \vdots \\ 0 & 0 & 0 & \dots & -k_n & k_n \end{bmatrix} \quad (21)$$

represent the system mass, damping and stiffness matrices, respectively. The MDOF system structure in the case of $n = 10$ is shown in Fig. 7.

In this numerical example, a 10-DOF system is used, therefore $n = 10$. For the healthy condition, the system structure parameters are chosen as $m_i = 0.8 \times 10^5$, $k_i = 4 \times 10^7$ and $c_i = 1.5 \times 10^6$ where $i = 1, \dots, 10$ [24]. For damaged conditions, 10 damage levels are introduced in the 2nd, 3rd and 5th coordinates where their stiffness parameters are reduced to the [90% 80% 70% 60% 50% 40% 30% 20% 10%] of their original values, respectively.

Following [18], the system input force is applied to the coordinates of the system one by one when the system output data are collected for the required analysis. The input signal is chosen as a multiple sine wave over frequency range from 1 Hz to 20 Hz, with the difference between two consecutive frequencies being 1 Hz. To confirm the excitation frequency range is wide enough, the frequency response of 1st coordinate is plotted in Fig. 8 and it can be seen that all the response peaks related to the main modes are below 20Hz.

In order to evaluate the performance of the proposed GTDI method, four different cases are considered. The first one

is an ideal case where the system inputs are applied to all the 10 coordinates one by one and all the system outputs are measured. The second case considers the outputs in the situation where only seven outputs are measured and the outputs at 3rd, 6th and 9th coordinates are not used. The third one conducts the required analysis when only the first two coordinates are subject to force inputs; while the fourth case considers the situation where the input frequency range is reduced to [1, 10] Hz. Meanwhile, the GTDI is also compared with the conventional TDI in all the cases.

As the length of data can be tuned easily and set sufficiently long in numerical simulations, the multiple samplings are not necessary, thereby choosing $g = 1$. Further, the system input is sequentially applied to each coordinate, therefore there are 10 input positions, leading to $Q = 10$. Finally, the number of multiple references S is also chosen as 1 first. If the results are not smooth, it can be increased gradually. When $S = 1$, GTDI and TDI have the same settings and their only difference lies in the number of the TFs involved. GTDI uses all TFs while TDI only uses adjacent TFs. To show the detailed information for the first case where the full frequency range is used and all the system outputs are measured, the responses at the 2nd coordinate under the reference case and the cases of different damage levels are shown in Fig. 9 and their corresponding spectra are plotted in Fig. 10. The TFs between 2nd coordinate and 3rd coordinate are shown in Fig. 11. It is clear that some significant changes can be observed in the TFs.

The GTDI and TDI based analysis results for these four cases are shown in Fig. 12. It is clearly shown that in all the cases both TDI and GTDI can detect the changes and their values decrease with the damage severity levels. The advantage of GTDI is that it is more sensitive to the damage severity. In other words, non-adjacent TFs can give more useful information and improve the detection accuracy. This is particularly useful for early warning of minor damage so as to prevent further deterioration by carrying out proper maintenance in time. As these results have clearly distinguished the differences of different damage levels, there is no need to increase reference number S any more. As mentioned in previous section, TDI and GTDI shares similar computational burden and the main computations are from FFT operations for 10 sensor data. In this simulation, it takes about 0.07 seconds to obtain the TDI or GTDI values.

VI. WIND TURBINE BEARING CONDITION MONITORING

Although wind energy industry has been significantly developed all over the world over the past few decades, the cost of the operation and maintenance is still very high. It is estimated that the cost for onshore wind turbines accounts to 10%-15% of total income while it is even higher for offshore wind turbines due to harsh working environment [2]. An efficient and effective condition monitoring method is therefore highly desirable in wind energy industry. The proposed GTDI can potentially address such problems. In this section, the real world wind turbine condition monitoring problem is considered. A condition monitoring system with 4 vibration sensors were used to monitor the main bearing of

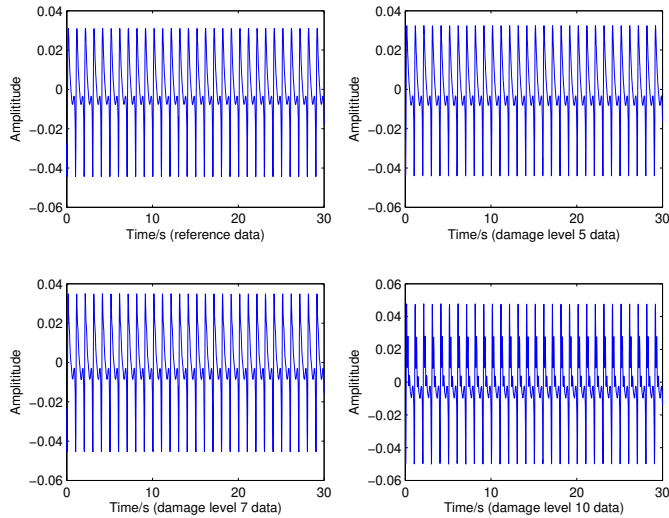

Fig. 9. The responses at the 2nd coordinate of the system under the reference and different damaging cases

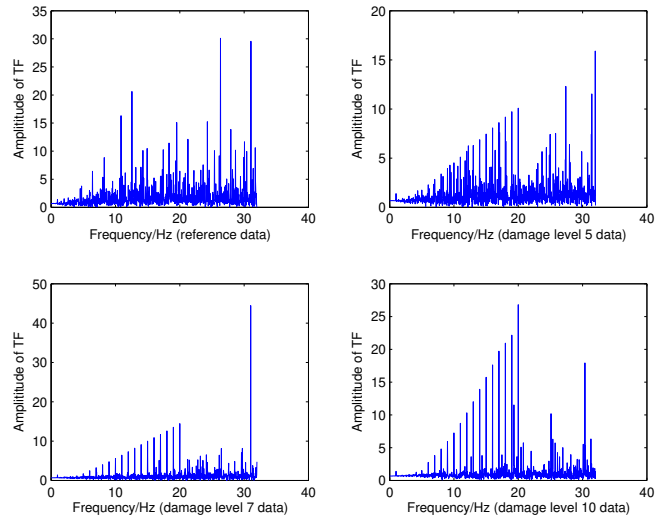

Fig. 11. The TFs between 2nd and 3rd coordinates under the reference and different damaging cases

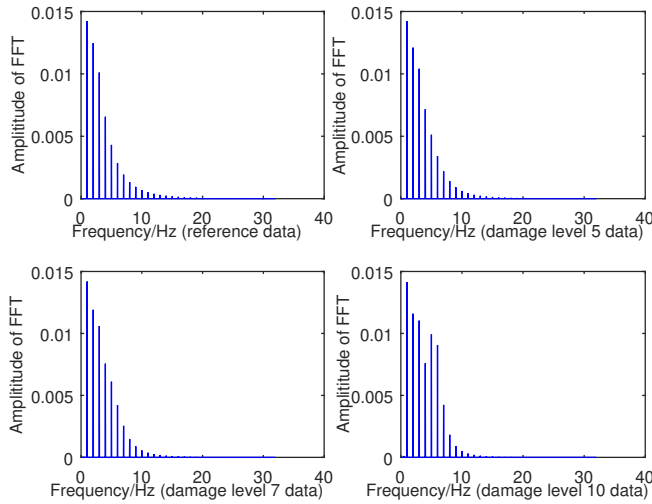

Fig. 10. The spectra of the system response at the 2nd coordinate under the reference and different damaging cases

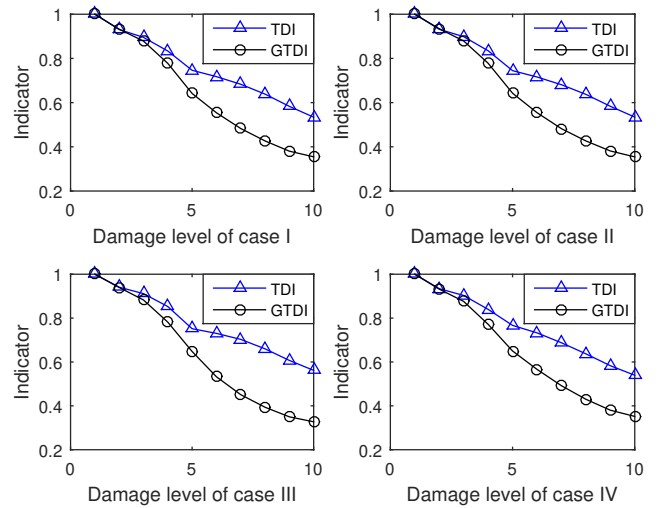

Fig. 12. The values of TDI and GTDI for all the cases of the numerical study

two operating Vestas 47 turbines with 660kW rated power, which is located in Profitis Ilias wind farm, Greece. It is known that one bearing was in good conditions while the other had some damage over the period of monitoring. The 4 vibration sensors were fitted at different locations along the main bearing. Each data collection lasted for 12 seconds and the sampling rate was 25 kHz. Data were collected over a period of 5 months. In total, 2190 sets of good condition data and 1800 sets of damaging condition data are available. A detailed description of the main bearing vibration data is given in Table I. Moreover, it is worth pointing out that generally the reference and in-service data are better to be collected from the same system. However, in the case, no healthy reference data was collected before damage occur. To deal with this problem, an alternative approach is used in which the healthy data from

another system that has the same physical structure as that of the damaged system is used as the healthy reference. As the TFs are determined by physical parameters, two systems with the same physical parameters can have the same or very similar TFs. Therefore, TF based condition monitoring methods can use another healthy system as a reference. This practice has been adopted by many other researchers as reported in [25], [26], [27], [5] where a healthy system was used as a reference to inspect the possible damage in a system of the same nature.

As all the data were collected in different periods, the variable loading conditions are naturally incorporated into the data sets. To observe the variable loading effects, the raw data of good condition and damaging condition data collected at different times are plotted in Fig. 13 and Fig. 14, respectively. Before computing the data spectra, the mean value from each data set is subtracted. Further, as the spectra amplitudes are

TABLE I
WIND TURBINE BEARING DATA SUMMARY

Turbine name	Profitis Ilias 14	Profitis Ilias 9
Conditions	Good	Bad
Time span	2014.02.27-2014.06.25	2013.12.10-2014.03.20
Sensor number	4	4
Quantity	2190 groups	1800 groups

very small, all the amplitudes are magnified 30 times to make them comparable in figures. Then the resultant spectra of good and damaging condition data are plotted in Fig. 15 and Fig. 16, respectively. Each sub-figure is labeled by the date when the data were collected, e.g. 20140324 representing 24 Mar 2014. It can be seen that the spectra varies with the date when data collection took place, indicating different loading condition on different dates. In general, for the good condition data spectra, the frequencies below 5 kHz have large amplitudes. For the damaging condition data spectra, some large amplitudes appear over frequencies above 10 kHz. From the plotted data spectra, it can be seen that the maximal amplitudes in the good condition are between 2.5 and 12 while the maximal amplitudes in the damaging condition are between 0.4 and 5. In other words, the amplitudes of good conditions are not overwhelmingly larger than those in the damaging conditions due to the overlapped range [2.5, 5]. Further, if all the data are considered, the amplitudes in the good and damaging conditions are even more overlapped. It is therefore not possible to determine the bearing condition only using the signal amplitude.

As the TFs amplitudes are very big, all the amplitudes are reduced by 100 times to make them comparable in figures. The FFT based TFs under good and damaging conditions are shown in Fig. 17 and Fig. 18, respectively. Following the suggestions in the previous section, three tunable parameters g, Q, S were all chosen as 1 first. Initially, 20 groups of good condition data and 20 groups of damaging condition data were used for testing the performance of the new GTDI method under these choices of parameters. It can be seen from the results in Fig. 19 that the differences between good and damaging conditions are clear. However, the results are not smooth due to the outlier in the resultant data. The outlier may be caused by inaccurate data spectra, dynamic loading, or large noise in the data.

To remove the outlier data point, the most widely used PSD algorithm, the welch method [20], was used to compute the more accurate data spectra and indicators of both TDI and GTDI are shown in Fig. 20. It can be seen that the PSD method can increase the similarity among good condition data and therefore makes the differences between good and damaging condition data analysis results more significant. However, it can not remove the outlier. To eliminate the outlier, the proposed schemes, namely the multiple data collections and references, were used for obtaining more accurate spectra and removing noise effects. As suggested in the previous section, first increase the number of data collections and then use multiple reference scheme if necessary. Here, $g = 2$ was

selected, that is, to emerge two groups of collected data, while leaving $Q = 1, S = 1$. The PSD method was then used to estimate the data spectra. As shown in Fig. 21 the outlier disappears in the new results. The feasibility of the proposed technique have therefore been demonstrated.

Using the same settings as the above test where $g = 2, Q = 1, S = 1$, all the data groups are tested and results are given in Fig. 22. It can be seen that overall GTDI produces better results than TDI in terms of distinguishing the differences between good and damaging conditions. However, both of them have many outliers due to the complex dynamic loadings and noisy data. To minimize the effects of these outliers, g and S were increased by trial and error. When choosing $g = 5, S = 2$ and $Q = 1$, the results are shown in Fig. 23. The differences between good and damaging conditions can be distinguished much more clearly. Further, compared to TDI where it has many outliers, the GTDI produces more consistent results with less outliers, due to the exploitation of the non-adjacent TFs. It is worth pointing out that in all the above results, TDI analysis also uses the new multiple data collections and references technique proposed in this paper. However, in the case where TDI does not use the new technique, its results are as shown in Fig. 24. It can be seen that TDI can not distinguish the damaging condition from the good one due to a large number of outliers. This is because TDI is not able to remove the dynamic loading and noise effects. By comparing these results shown in Fig. 23 and Fig. 24, the advantages of the proposed techniques have been further demonstrated. To qualitatively evaluate the advantage of GTDI over TDI, a misrecognition ratio that is defined as the ratio between number of false alarms and the total monitored instances is used. In this paper, the threshold is chosen as 0.5. If the value of GTDI or TDI is above 0.5, it means healthy. Otherwise, it means damaging. As can be seen in Fig. 23, for GTDI, there is no false alarm and its misrecognition ratio is 0. As shown in Fig. 24, for TDI, its misrecognition ratio is $296/3990=7.42\%$. GTDI outperforms the TDI in term of misrecognition ratio without sacrificing its computing time. GTDI and TDI have the same main computing requirements, namely 4 sensor data spectra of 300000 data points. In this case, it takes about 1.5 seconds to obtain a TDI or GTDI value. This demonstrates that GTDI has the potential for online condition monitoring due to its low computational burden.

VII. CONCLUSION

In the present study, a new generalized transmissibility damage indicator (GTDI) has been proposed for condition monitoring. The proposed GTDI is able to remove dynamic loadings and noise effects by using multiple data collections, all transmissibility functions, and multiple references. It is a simple and easily implemented method where its main computation is from the calculations of data spectra. Further, the new indicator does not require any priori knowledge, and therefore can be used for the condition monitoring of any type of systems. Results from both simulations and an operating wind turbine main bearing condition monitoring have verified the effectiveness of the proposed techniques.

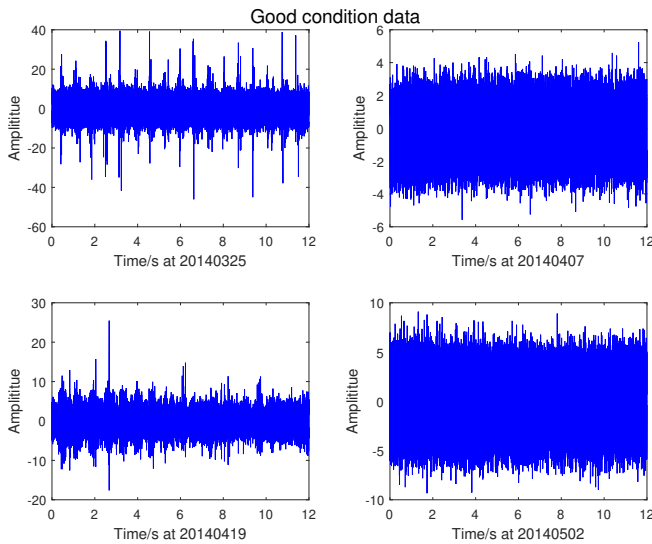

Fig. 13. Time series data of good condition collected at different times

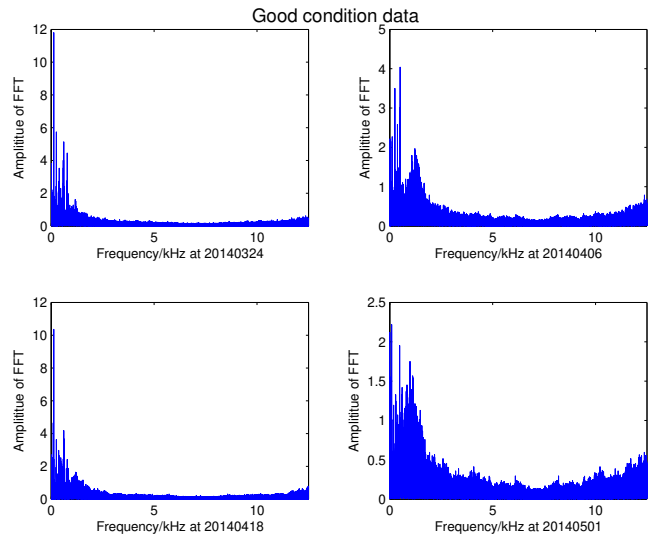

Fig. 15. Spectra of good condition data collected at different times

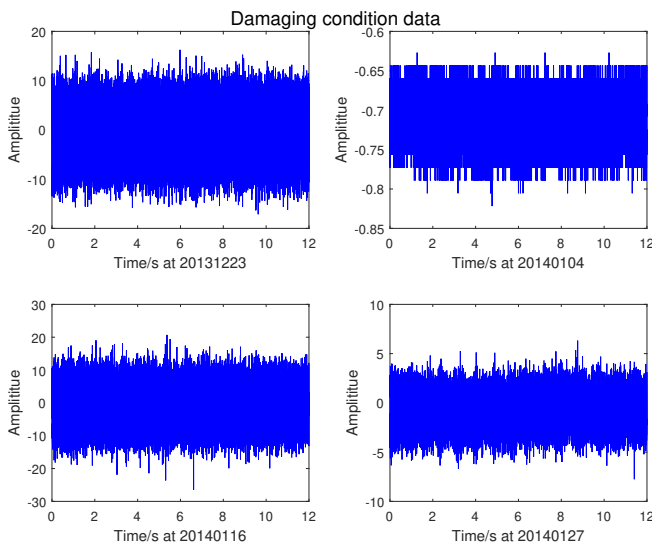

Fig. 14. Time series data of damaging condition collected at different times

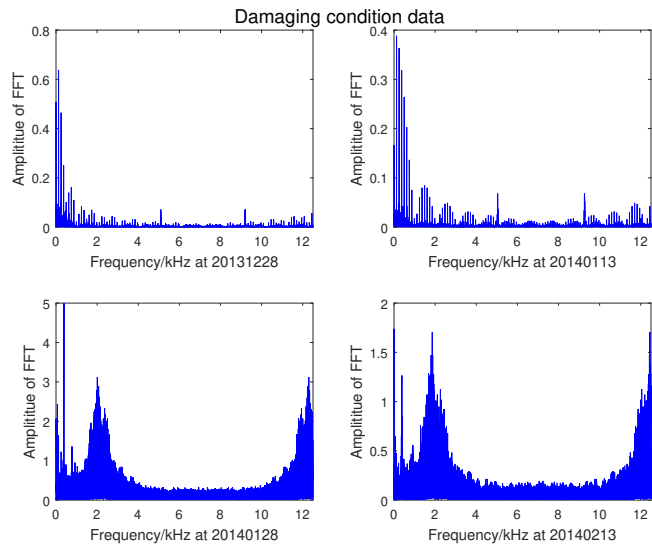

Fig. 16. Spectra of damaging condition data collected at different times

ACKNOWLEDGEMENT

The authors would like to acknowledge the support of EU FP7 optimus grant for this research work and thank D2S international for providing the main bearing vibration data.

REFERENCES

[1] J. Gertler, *Fault detection and diagnosis in engineering systems*. CRC press, 1998.
 [2] B. Lu, Y. Li, X. Wu, and Z. Yang, "A review of recent advances in wind turbine condition monitoring and fault diagnosis," in *IEEE Power Electronics and Machines in Wind Applications (PEMWA), 2009*. IEEE, 2009, pp. 1–7.
 [3] D. McMillan and G. W. Ault, "Quantification of condition monitoring benefit for offshore wind turbines," *Wind Engineering*, vol. 31, no. 4, pp. 267–285, 2007.
 [4] A. R. Mohanty and C. Kar, "Fault detection in a multistage gearbox by demodulation of motor current waveform," *IEEE Transactions on Industrial Electronics*, vol. 53, no. 4, pp. 1285–1297, 2006.

[5] R. B. Randall and J. Antoni, "Rolling element bearing diagnostics a tutorial," *Mechanical Systems and Signal Processing*, vol. 25, no. 2, pp. 485–520, 2011.
 [6] R. Zimroz, W. Bartelmus, T. Barszcz, and J. Urbanek, "Diagnostics of bearings in presence of strong operating conditions non-stationarity a procedure of load-dependent features processing with application to wind turbine bearings," *Mechanical Systems and Signal Processing*, vol. 46, no. 1, pp. 16–27, 2014.
 [7] R. Zimroz and A. Bartkowiak, "Two simple multivariate procedures for monitoring planetary gearboxes in non-stationary operating conditions," *Mechanical Systems and Signal Processing*, vol. 38, no. 1, pp. 237–247, 2013.
 [8] C. W. De S., *Vibration monitoring, testing, and instrumentation*. CRC Press, 2012.
 [9] C. Cempel and M. Tabaszewski, "Multidimensional condition monitoring of machines in non-stationary operation," *Mechanical Systems and Signal Processing*, vol. 21, no. 3, pp. 1233–1241, 2007.
 [10] M. J. Schulz, A. S. Naser, P. F. Pai, M. S. Linville, and J. Chung, "Detecting structural damage using transmittance functions," in *Proceedings SPIE the International Society for Optical Engineering*. SPIE the International Society for Optical Engineering, 1997, pp. 638–644.
 [11] H. F. Zhang, M. J. Schulz, A. Naser, F. Ferguson, and P. F. Pai, "Structural health monitoring using transmittance functions," *Mechani-*

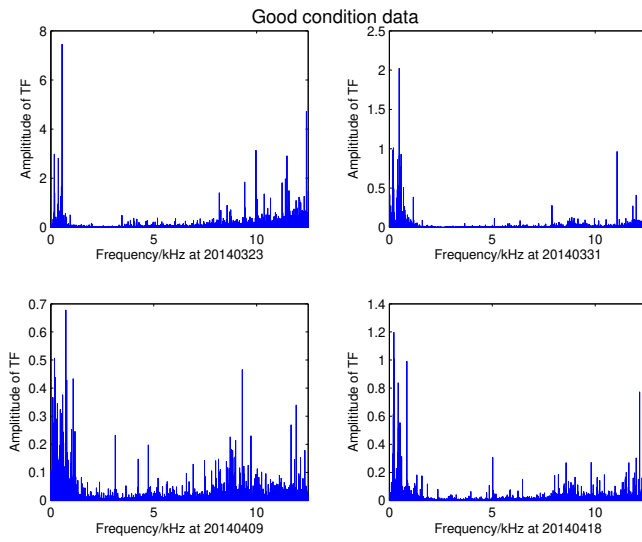

Fig. 17. TFs of good condition data collected at different times

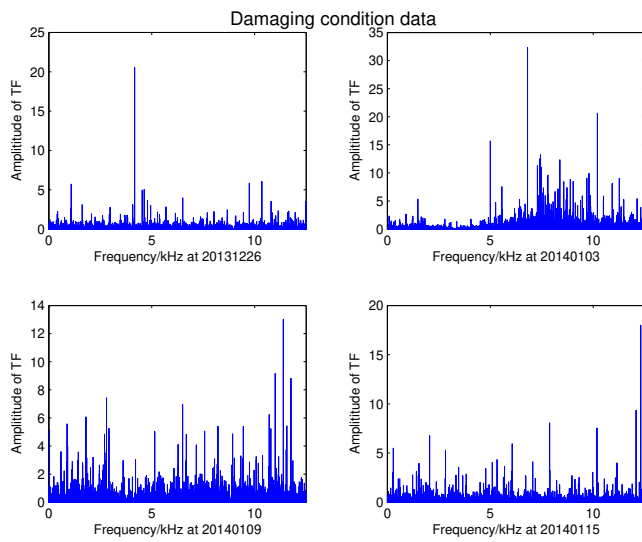

Fig. 18. TFs of damaging condition data collected at different times

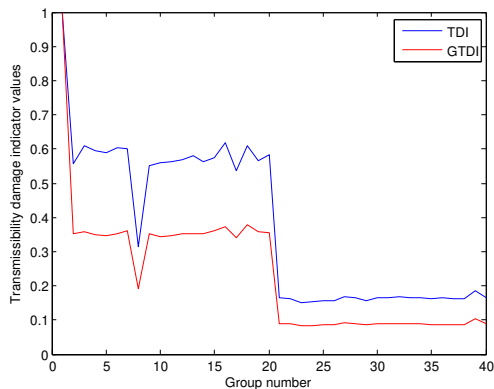

Fig. 19. FFT based transmissibility damage indicator values for 40 groups of data

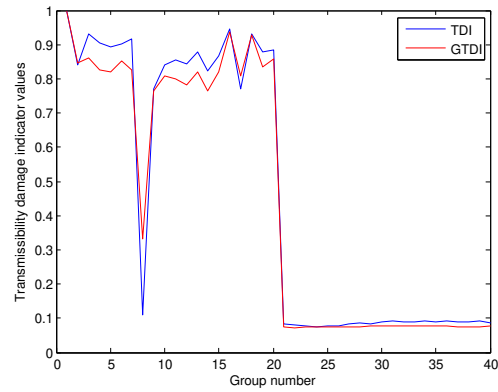

Fig. 20. PSD based transmissibility damage indicator values for 40 groups of data

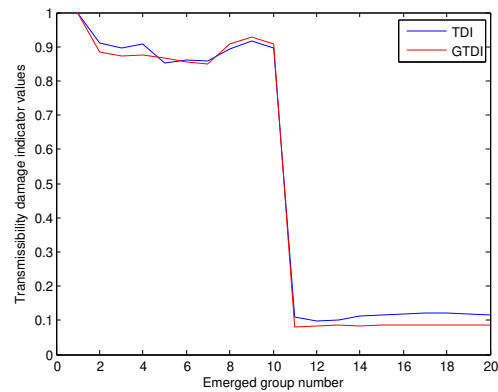

Fig. 21. PSD based transmissibility damage indicator values evaluated using emerged groups of data with $g = 2, S = 1, Q = 1$

cal Systems and Signal Processing, vol. 13, no. 5, pp. 765–787, 1999.

[12] W. J. Liu and D. J. Ewins, “Transmissibility properties of MDOF systems,” in *Proceedings SPIE the International Society for Optical Engineering*, vol. 2. SPIE the International Society for Optical Engineering, 1998, pp. 847–854.

[13] A. M. R. Ribeiro, J. M. M. Silva, and N. M. M. Maia, “On the generalisation of the transmissibility concept,” *Mechanical Systems and Signal Processing*, vol. 14, no. 1, pp. 29–35, 2000.

[14] T. J. Johnson and D. E. Adams, “Transmissibility as a differential indicator of structural damage,” *Journal of Vibration and Acoustics*, vol. 124, no. 4, pp. 634–641, 2002.

[15] S. Chesné and A. Deraemaeker, “Damage localization using transmissibility functions: a critical review,” *Mechanical systems and signal*

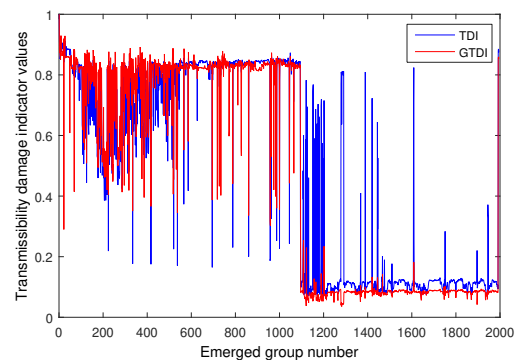

Fig. 22. PSD based transmissibility damage indicator values evaluated from emerged groups of data with $g=2, S=1$ and $Q=1$

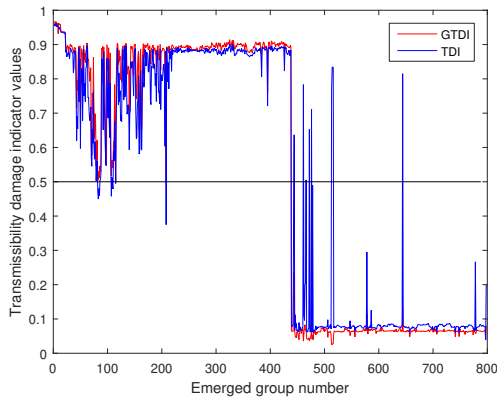

Fig. 23. Transmissibility damage indicator values evaluated from emerged groups of data with $g=5$, $S=2$ and $Q=1$

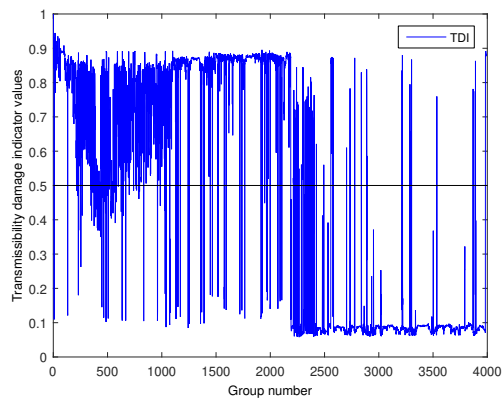

Fig. 24. Transmissibility damage indicator values using TDI but without using multiple data collections and references proposed in the present study

bearings, part i: bearing stiffness formulation,” *Journal of sound and vibration*, vol. 139, no. 2, pp. 179–199, 1990.

- [24] X. Y. Zhao, Z. Q. Lang, G. H. Park, C. R. Farrar, M. D. Todd, Z. H. Mao, and K. Worden, “A new transmissibility analysis method for detection and location of damage via nonlinear features in mdoof structural systems,” *IEEE/ASME transactions on Mechatronics*, vol. 20, no. 4, pp. 1933–1947, 2015.
- [25] W. Bartelmus and R. Zimroz, “Vibration condition monitoring of planetary gearbox under varying external load,” *Mechanical Systems and Signal Processing*, vol. 23, no. 1, pp. 246–257, 2009.
- [26] W. Bartelmus, F. Chaari, R. Zimroz, and M. Haddar, “Modelling of gearbox dynamics under time-varying nonstationary load for distributed fault detection and diagnosis,” *European Journal of Mechanics-A/Solids*, vol. 29, no. 4, pp. 637–646, 2010.
- [27] G. K. Chaturvedi and D. W. Thomas, “Bearing fault detection using adaptive noise cancelling,” *Journal of Mechanical Design*, vol. 104, no. 2, pp. 280–289, 1982.

processing, vol. 38, no. 2, pp. 569–584, 2013.

- [16] T. J. Johnson, R. L. Brown, D. E. Adams, and M. Schiefer, “Distributed structural health monitoring with a smart sensor array,” *Mechanical Systems and Signal Processing*, vol. 18, no. 3, pp. 555–572, 2004.
- [17] K. Worden, G. Manson, and D. Allman, “Experimental validation of a structural health monitoring methodology: Part i. novelty detection on a laboratory structure,” *Journal of Sound and Vibration*, vol. 259, no. 2, pp. 323–343, 2003.
- [18] N. M. M. Maia, R. A. B. Almeida, A. P. V. Urgueira, and R. P. C. Sampaio, “Damage detection and quantification using transmissibility,” *Mechanical Systems and Signal Processing*, vol. 25, no. 7, pp. 2475–2483, 2011.
- [19] Z. Q. Lang, G. Park, C. R. Farrar, M. D. Todd, Z. Mao, L. Zhao, and K. Worden, “Transmissibility of non-linear output frequency response functions with application in detection and location of damage in MDOF structural systems,” *International Journal of Non-Linear Mechanics*, vol. 46, no. 6, pp. 841–853, 2011.
- [20] P. Welch, “The use of fast fourier transform for the estimation of power spectra: a method based on time averaging over short, modified periodograms,” *IEEE Transactions on audio and electroacoustics*, vol. 15, no. 2, pp. 70–73, 1967.
- [21] C. Devriendt, F. Presezniak, D. G. D. Sitter, K. Vanbrabant, T. D. Troyer, S. Vanlanduit, and P. Guillaume, “Structural health monitoring in changing operational conditions using transmissibility measurements,” *Shock and Vibration*, vol. 17, no. 4-5, pp. 651–675, 2010.
- [22] G. Manson, K. Worden, and D. Allman, “Experimental validation of a structural health monitoring methodology: Part iii. damage location on an aircraft wing,” *Journal of Sound and Vibration*, vol. 259, no. 2, pp. 365–385, 2003.
- [23] T. C. Lim and R. Singh, “Vibration transmission through rolling element