



Deposited via The University of Sheffield.

White Rose Research Online URL for this paper:

<https://eprints.whiterose.ac.uk/id/eprint/107364/>

Version: Accepted Version

---

**Article:**

Garcia, R., Guadagnini, M., Pilakoutas, K. et al. (2017) Fibre-reinforced polymer strengthening of substandard lap-spliced reinforced concrete members: A comprehensive survey. *Advances in Structural Engineering*, 20 (6). pp. 976-1001. ISSN: 1369-4332

<https://doi.org/10.1177/1369433216668362>

---

**Reuse**

Items deposited in White Rose Research Online are protected by copyright, with all rights reserved unless indicated otherwise. They may be downloaded and/or printed for private study, or other acts as permitted by national copyright laws. The publisher or other rights holders may allow further reproduction and re-use of the full text version. This is indicated by the licence information on the White Rose Research Online record for the item.

**Takedown**

If you consider content in White Rose Research Online to be in breach of UK law, please notify us by emailing [eprints@whiterose.ac.uk](mailto:eprints@whiterose.ac.uk) including the URL of the record and the reason for the withdrawal request.

# FRP strengthening of substandard lap-spliced RC members: a comprehensive survey

Reyes Garcia<sup>a\*</sup>, Maurizio Guadagnini<sup>a</sup>, Kypros Pilakoutas<sup>a</sup>, Luis A. Pech Poot<sup>b</sup>

<sup>a</sup> Dept. of Civil and Structural Engineering, The University of Sheffield, Sir Frederick Mappin Building, Mappin Street, Sheffield, S1 3JD, UK.

<sup>b</sup> Dept. of Construction Engineering, Universitat Politècnica de Catalunya, Jordi Girona 1-3, 08034 Barcelona, Spain.

Tel.: +44 (0) 114 222 5071. Fax: +44 (0) 114 222 5700

Email (corresponding author\*): [r.garcia@sheffield.ac.uk](mailto:r.garcia@sheffield.ac.uk)

## Abstract

Externally bonded Fibre Reinforced Polymer (FRP) confinement is extensively used to improve the bond strength of substandard lap spliced steel bars embedded in reinforced concrete (RC) components.

However, the test results from bond tests on such bond-deficient components are not fully conclusive, which is reflected in the few design guidelines available for FRP strengthening. For the first time, this article presents a comprehensive survey on FRP strengthening of substandard lap-spliced RC members, with emphasis on the adopted experimental methodologies and analytical approaches developed to assess the effectiveness of FRP at controlling bond-splitting failures. The main findings and shortcomings of previous investigations are critically discussed and further research needs are identified. This review contributes towards the harmonisation of testing procedures so as to facilitate the development of more accurate predictive models, thus leading to more cost-effective strengthening interventions.

**Keywords:** *lap splices; seismic strengthening; RC columns; FRP confinement; bond strength*

# 1 Introduction

Since the 1994 Northridge and 1995 Hyogoken-Nanbu (Kobe) earthquakes, externally bonded Fibre Reinforced Polymers (FRP) have been widely used for the local strengthening of substandard lap-spliced regions of reinforced concrete (RC) columns of bridges and buildings. Typical applications involve bonding FRP fabric sheets or precured shells around a column to provide additional confinement (see Figure 1(a)), thus enhancing the lap bond strength and preventing a premature splitting failure. In the last decades, extensive experimental research has confirmed the effectiveness of FRP confinement at improving the behaviour of RC members with inadequate short lapped bars (Aboutaha et al. 1996, Saadatmanesh et al. 1996, Saadatmanesh et al. 1997b, Seible et al. 1997, Tastani and Pantazopoulou 2001, Bousias et al. 2006, Harries et al. 2006, Ghosh and Sheikh 2007, Harajli and Dagher 2008, ElGawady et al. 2010, Bournas and Triantafillou 2011). Due to the large number of parameters affecting the bond behaviour of lapped bars, different experimental and analytical approaches were adopted to evaluate the effectiveness of FRP confinement. In general however, two experimental approaches are mainly implemented:

**(a) Capacity-ductility approach.** The tests in these pioneering studies aim at assessing the enhancement in capacity and/or ductility of columns provided by the FRP confinement. Based on these experiments, some analytical models were proposed to compute the thickness of FRP required to prevent lap splice failure (e.g. Seible et al. 1997, Hawkins et al. 2000, Elnabesy and Saatcioglu 2004, Elsanadedy and Haroun 2005).

**(b) Bond strength approach.** The bond strength enhancement provided by FRP reinforcement is examined using test specimens recommended in state-of-the-art reports on bond (e.g. *fib* Bulletin 10 (2000) or ACI 408 (2012)) including pullout, beam-end and beam specimens. The contribution of the FRP reinforcement is evaluated from the increase in the observed bond strength.

Despite the extensive research, the majority of the previous studies focused on lap-spliced circular columns. Conversely, less research has been carried out to investigate the effectiveness of FRP as a strengthening solution for substandard rectangular members of RC buildings, and only a few existing guidelines (AIJ 2002, BSI 2005, TEC 2007, CNR 2012, EPPO 2012) address these issues.

This article presents a comprehensive literature review on substandard lap-spliced RC members strengthened with externally bonded FRP. Special emphasis is placed on the experimental methodology and analytical approaches adopted to study the effectiveness of this strengthening method. Conflicting research findings and aspects requiring further research are discussed and commented upon. This article contributes towards the harmonisation of testing and assessment procedures in a timely manner as current European guidelines (e.g. *fib* Bulletin 14 (2001) and Eurocode 8 Part 3 (2005)) are currently under revision and both of them are envisaged to adopt *bond strength approaches* for the FRP strengthening of laps.

## **2 Assessment of FRP reinforcement effectiveness through testing**

The experimental methodologies used to assess the effectiveness of external FRP reinforcement on lap-spliced RC members can be classified according to the approaches (a) and (b) described before.

### **2.1 Capacity-ductility approach: tests on cantilever columns**

Cantilever columns have been extensively tested in the past (Priestley et al. 1992, Priestley and Seible 1995, Saadatmanesh et al. 1996, Saadatmanesh et al. 1997b, Saadatmanesh et al. 1997a, Seible et al. 1997, Xiao and Ma 1997, Haroun et al. 1999, Ma and Xiao 1999, Chang et al. 2000, Ma et al. 2000, Chang et al. 2001, Saatcioglu and Elnabelsy 2001, Haroun et al. 2003, Elnabelsy and Saatcioglu 2004, Sause et al. 2004, Schlick and Breña 2004, Yalçın and Kaya 2004, Haroun and Elsanadedy 2005, Bousias et al. 2006, Bousias et al. 2007, Breña and Schlick 2007, Youm et al. 2007, Chung et al. 2008, Eshghi and Zanjanzadeh 2008, Harajli 2008, ElGawady et al. 2010, Bournas and Triantafillou 2011, Kim et al. 2011). Column specimens are usually cast on a stiff concrete block simulating the structure's foundation, as shown in Figure 1. The longitudinal column reinforcement is lapped at the base for typical short lengths  $l_b \approx 20-30d_b$  (where  $d_b$ =bar diameter) to replicate old construction practices and to promote bond splitting failure. Columns are commonly tested in vertical position by applying increasing quasi-static cyclic lateral loads or displacements, although horizontal specimens have been also tested (Harajli and Rteil 2004, Ilki et al. 2004, Ghosh and Sheikh 2007, Thermou and Pantazopoulou 2009). A constant axial load is usually applied to the column, but columns with no axial load have been also tested (Harajli and Dagher 2008, Harajli and Khalil 2008, ElSouri and Harajli 2011, Kim et al. 2011). The effectiveness of

the FRP strengthening is assessed by comparing the results of the original ‘as-built’ and FRP-strengthened columns in terms of enhancements in capacity, ductility and energy dissipation (hysteresis loops).

As expected, unstrengthened ‘as built’ columns failed prematurely due to splitting of the concrete cover around the lapped bars, leading to a rapid strength and stiffness degradation. Comparatively, the FRP-confined columns generally failed in a ductile manner by yielding of the lapped bars, accompanied by partial splitting (i.e. less severe cracking), bar pullout or bar buckling. Whilst all studies reported significant enhancements in the capacity and ductility of the strengthened columns, the magnitude of the enhancement varies considerably from one study to another given the different geometries and test conditions adopted.

## **2.2 Bond strength approach**

Specimens tested using this approach provide insight into the basic behaviour of anchorages and lap splices in FRP-strengthened members. In general, the unstrengthened specimens are designed to fail prematurely by cover splitting. Short bonded lengths are commonly selected to produce a uniform distribution of bond force along the bars and to prevent bar yielding. The effectiveness of the strengthening is evaluated by comparing the bond strength of unstrengthened and FRP-strengthened specimens, as well as load-deflection and/or bond stress-bar slip relationships.

### **2.2.1 “Pullout” tests**

Kono and co-workers (1997, 1999, 2000) tested “Schmidt-Thrö” pullout specimens with a single or four anchored bar as shown in Figure 2(a)-(b) and (d)-(e). A vertical slot defined the bonded length at the end of the specimens ( $l_b=4-12d_b$  or 100-300 mm) and prevented the application of compression forces in the concrete around the bar. The use of a single layer of Carbon FRP (CFRP) fabric across the anchorage length led to a more ductile pullout failure and enhanced the bar bond strength by an average of 80%. Kono et al. concluded that the bond strength enhancement was independent of the bonded length of the bar.

More recently, Tastani and Pantazopoulou (2010) performed direct pullout tests using two bars anchored concentrically in a concrete prism (Figure 2(c)). Specially machined steel bars with two different nominal

rib heights were anchored for short lengths ( $l_b=5d_b$  or  $12d_b$ ) at the testing end of the specimens, whereas a commercial bar with sufficient bonded length was anchored at the support end (shown as  $l_r$  in Figure 2(c)). Two layers of CFRP fabric were bonded on each face of the specimens (parallel to the longitudinal axis) to transfer forces between the testing ends and to prevent failure of the concrete prism in tension. A confinement sheet was added around the support bar to improve its development capacity. For the specimens designed to evaluate to effect of confinement on the bond strength, and FRP sheet was also wrapped around the test bar. Presplit specimens with a radial crack 1.0 mm wide were also tested (see testing end in Figure 2(c)). Average bond strengths increased by up 130% and 44% in non-split and presplit specimens, respectively, but the bond strength results showed a large scatter. This was attributed to the highly variable properties of concrete in tension (Tastani and Pantazopoulou 2010).

### **2.2.2 Beam-end specimens**

Kono et al. (1999, 2000) conducted tests on small beam-end specimens with two or four bars anchored for a length  $l_b=300$  mm as shown in Figure 2(d)-(e). One, two or three layers of Aramid FRP (AFRP) or CFRP strips were wrapped along the anchorage length of the bars, whereas internal steel stirrups were also provided to confine the bars and the specimens' core. The confinement enhanced the bond strength of the bars by a minimum of 18% and up to 44%. Despite the heavy internal reinforcement, the diagonal cracking observed across some of the specimens at failure suggests that shear (rather than splitting) dominated the behaviour. This can be possibly attributed to the small shear span ratio used in the tests (close to 1) and the resulting high shear forces.

In an attempt to eliminate shear and 'active' confinement effects due to loading at the supports, Ozden and Akpınar (2007) tested H-shaped beam-end specimens with an anchored bar confined with either Glass FRP (GFRP) or CFRP sheets (see Figure 2(f)). Very short anchorage lengths of  $l_b=3.5d_b$  and  $7d_b$  were selected to study local bond conditions. No internal steel stirrups were provided. The concrete cover was set constant and equal to  $1d_b$  in all specimens. The bond strength of the anchored bars was enhanced by 16% and up to 42% when compared to unconfined specimens.

### 2.2.3 Beam specimens

Kono et al. (1997, 1999) also tested large-scale beams in double curvature in an attempt to produce cover splitting within the midspan zone (see Figure 3). Different confining configurations were investigated including: a) one layer of CFRP strips or continuous confinement (Kono et al. 1997), and b) one or two layers of AFRP or CFRP strips (Kono et al. 1999). The beams failed at midspan due to a combination of shear and cover splitting. The shear strength of the beams was enhanced by approximately 80% with reference to unconfined counterparts. Although bond strength of the bars was enhanced by up to 115%, the different force mechanisms involved in the final failure make the interpretation of results difficult.

Hamad and Najjar (2002), Salwan (2003) and Hamad and co-workers (2004a, 2004b, 2004c) tested beam splice specimens in four-point bending to examine the effect of FRP wraps on the bond strength of lap splices (see Figure 4). The specimens were designed to fail by splitting at midspan, where the main flexural reinforcement was lapped for a short length  $l_b=16d_b$  to prevent bar yielding. One or two layers of GFRP or CFRP were bonded along the midspan zone using partial (1 or 2 strips) or continuous U-wraps. Whilst the unconfined beams experienced sudden brittle failure due to severe splitting and spalling of the concrete cover around the lapped bars, the FRP-strengthened beams failed gradually. The FRP reinforcement also enhanced the bond strength of the splice by a minimum of 6% and up to 34% when compared to unconfined beams (Hamad and Rteil 2006). Unlike Kono et al.'s specimens, beam splice specimens are subjected to simple bending at the midspan, thus simplifying the comparison of results.

Harajli (2006) tested beam splice specimens to investigate the local bond-bar slip relationship of very short lap splices with  $l_b=5d_b$  (see Figure 5). The beams were subjected to four-point bending using static and cyclic loading. Two notches at the bottom of the beams defined the lap length and exposed the main flexural bars for slip measurements. As expected, failure of the unconfined specimens was controlled by splitting. The use of one or two layers of CFRP at the lap zone was effective at delaying failure and enhancing the bond strength of the lapped bars by up to 70% with reference to the unconfined counterparts.

Rteil et al. (2007) performed four-point bending tests (as shown in Figure 6) on beam anchorage specimens under static and fatigue loading. A bond splitting failure was promoted at the beam ends by

anchoring the bottom bars for a short length of approximately  $l_b \approx 13d_b$ . The rest of the bar length was unbonded from the concrete using polyethylene pipes. Two notches at the bottom of the beams defined the lap length at the beam ends and exposed the main flexural bars for measurements. The anchored bar zone was strengthened with one layer of U-shaped CFRP fabric. The bond strength of the CFRP-confined beams subjected to static load was enhanced by 38% with reference to the unconfined counterparts. Likewise, the bond strength of CFRP-confined beams subjected to fatigue load increased by 41% at 1000 cycles, and by 22% at 100,000 cycles compared to unconfined specimens. Whilst bar slip increased with the number of applied cycles, the slip in the unconfined beams increased exponentially during the last 10% of the beams' life, whereas the slip increased constantly up to failure in CFRP-confined beams. Similar beam anchorage specimens were tested by Hage Ali (2003), but in this case the bond strength was enhanced by 6% and up to 9% only. Due to the test set-up, bond strength results obtained from these beams may be influenced by additional confining stresses generated by the reaction forces at the supports. It is unclear if this effect was considered in the reported results.

More recently, Garcia et al. (2014, 2015) investigated the bond strength enhancement resulting from the confinement provided by CFRP sheets in 24 beam splice specimens tested in flexure, similar to those tested by Harajli et al. (2006) and Hamad et al. (Hamad et al. 2004a, Hamad et al. 2004b, Hamad et al. 2004c). Lap lengths of  $10d_b$  and  $25d_b$  were used to examine the mobilised "local" and average bond strengths, respectively. 1 or 2 layers of continuous CFRP fabric confined full lap length. The experimental results showed that the CFRP strengthening enhanced the bond strength of the lapped bars by up to 65% with reference to unconfined beams, thus improving significantly the overall behaviour of the beam splice specimens. The results also corroborated research findings by Kono et al. (1997) as the bond strength enhancement was relatively independent of the lap length.

### **3 Discussion of parameters influencing the effectiveness of FRP confinement**

The literature survey indicates that extensive research on the subject has been performed until now. The different approaches adopted to investigate the bond behaviour of lap spliced elements strengthened with

FRP also reflect the numerous parameters influencing bond behaviour and the effectiveness of FRP confinement, as discussed in the following.

### 3.1 Type of specimen and lap splice length

The lap length used to investigate the effect of FRP confinement on lap-spliced members is generally selected on the basis of the adopted experimental approach and on the level of stress expected to be developed in the bars. When test specimens are designed according to a *capacity-ductility approach*, FRP confinement has a minor influence if laps are relatively short and bar pullout dominates failure.

Conversely, the influence of confinement is important when concrete splitting dominates failure. For instance, in columns with relatively long splices ( $l_b > 35-40d_b$ ), the confinement provided by the concrete cover and internal stirrups may be sufficient to develop yielding in the bars, resulting in rather stable and ductile hysteresis loops. Consequently, the behaviour of these columns is only slightly improved by additional FRP confinement at the lapped zone (Bousias et al. 2007, ElGawady et al. 2010, Bournas and Triantafillou 2011). The improvement is particularly evident at higher ductility levels of response when the FRP confinement prevents premature spalling of the concrete cover and delay possible buckling of the spliced bars (Pantazopoulou et al. 2015).

Although FRP confinement has proven very effective at improving the behaviour of lap-spliced columns, the majority of the tested specimens to date differ considerably in size and geometry, bar and concrete characteristics, type and layout of the FRP confinement, and lap length. Due to this lack of uniformity, the results and conclusions drawn from an experimental programme may not be directly comparable to others. Additionally, the effect of FRP strengthening on the local bond behaviour is difficult to assess due to the practical difficulties in monitoring the strains along the lapped bars (unless closely spaced strain gauges are fixed on the bars).

In general, when a *bond strength approach* is adopted in the investigations, the selected bonded length depends on whether local or average bond strength is of interest. Bonded lengths of anchorages and lap splices are usually “short” enough to prevent bar yielding so that the bond mechanism is not affected (i.e.  $l_b < l_{b,\min}$ , where  $l_{b,\min}$  = minimum bonded length), but also sufficiently “long” to allow the contribution of a considerable number of bar ribs to bond resistance. The test specimens described previously in Section

2.2 follow this rationale and adopted lap lengths in the range  $5d_b \leq l_b \leq 15d_b$ . The results of these specimens can be also useful, for instance, to adjust existing bond-slip relationships so as to account for the FRP strengthening.

Given the different factors affecting bond, an experimental methodology that combines the use of tests on standard specimens (e.g. beam-end or beam splice specimens), along with tests on lap splice lengths typical of substandard RC columns ( $l_b=20-30d_b$ ), can provide a valuable insight into the bond behaviour of FRP-confined members. It should be also noted that current bond provisions of modern design codes such as ACI 318 (2011) and *fib* Model Code 2010 (2010) were developed using large databases of test results from beam splice specimens. As a consequence, these beams can provide suitable data to develop bond strength models that can be included in future revisions of FRP guidelines.

### **3.2 Layout and thickness of FRP reinforcement**

The use of different FRP reinforcement layouts and thickness/number of layers ( $n_f t_f$ ) was investigated by several researchers. The effectiveness of discontinuous FRP reinforcement (strips) has been studied in columns (Harajli and Rteil 2004), beam-end and beam specimens (Kono et al. 1997, Kono et al. 1999, Kono et al. 2000), and beam splice specimens (Hamad et al. 2004a, 2004b, 2004c). Compared to continuous strengthening applications, discontinuous reinforcement is less effective and therefore rarely used in practical wet lay-up applications. The strengthening of lap-spliced members usually involves the full wrapping of the cross section with FRP sheets. Nonetheless, U-shaped FRP sheets have been successfully used in beam specimens as shown in Figure 4(b) and Figure 6(b). Whilst U-wraps are less effective than full wraps, they are generally more practical for strengthening beams where the presence of a slab could prevent full wrapping. Such a confinement layout however is rarely required in columns, which are more vulnerable than beams. As a result, it is recommended that future tests focus on investigating continuous and either full or U-wrap strengthening applications.

Practical strengthening applications generally use a minimum of one continuous layer of fully wrapped FRP reinforcement. This minimum amount of FRP confinement may be sufficient to develop the full capacity of RC columns with typical lap splices of length  $l_b=20-30d_b$  (e.g. Breña and Schlick 2007, Ghosh and Sheikh 2007, Harajli and Dagher 2008, Harajli and Khalil 2008, ElSouri and Harajli 2011,

Garcia et al. 2014). Additional FRP layers can provide more confining pressure to the lap splice, enhancing its bond strength and improving further the specimen behaviour. However, similarly to confinement by internal steel reinforcement, FRP confinement only enhances bond strength up to the point where bar pullout dominates failure. Few researchers have investigated experimentally the maximum achievable bond strength enhancement as a function of the amount of FRP confinement (Hamad et al. 2004a, Harajli et al. 2004). In addition, the effectiveness of FRP confinement is limited by yielding of the lapped bars as bond strength increases only marginally after this point (Harajli and Dagher 2008). As no significant bond enhancement is expected in the post-yield stage, it seems uneconomical to provide more confinement than that necessary to develop yielding of the bars (unless it is required for other strengthening objectives). Indeed, previous research (Hamad et al. 2004a, 2004b, 2004c, Garcia et al. 2014) suggests that the use of two layers of FRP can be sufficient to mobilise the maximum achievable bond strength of typical lap splices.

### **3.3 Strains developed in the FRP**

Due to their intrinsic mechanical characteristics, FRP remain essentially elastic until failure. As a result, the confining stress ( $f_l$ ) applied by the FRP reinforcement on a lap-spliced member depends on the effective strain ( $\epsilon_{fe}$ ) developed in the main direction of the fibres. Despite of this, not all experimental studies provide sufficient information on the evolution of FRP strains to allow evaluating the effective confining stress at bond failure. In the case of lap spliced columns, studies often report “maximum” FRP strains recorded at the last test stages, when significant concrete cover spalling, concrete crushing and/or bar buckling can affect the strain readings. Additionally, FRP strains are also affected by the location of the strain gauges along the member and across the cross section. For instance, large FRP strains are usually recorded close to the base of columns (Ma and Xiao 1999, Schlick and Breña 2004). While such large strains have been mainly attributed to the variation of flexural moment over the column height, they could also be a result of the development of other degradation mechanisms (e.g. bar buckling). Also, very high strain values can be recorded near the corner of rectangular sections where rupture of the FRP confinement is more likely to occur (Walkup 1998, Sause et al. 2004).

In lap spliced members, the effectiveness of the passive confining action from the FRP relies heavily on concrete dilation around the lapped bars, which in turn depends on bar slip (e.g. Tastani and

Pantazopoulou 2008, 2010). Test results from lap-spliced circular columns indicate that the ‘onset’ of bar slip occurs at dilation strains between 1000 and 2000  $\mu\epsilon$  (Seible et al. 1995). Based on this observation, a limiting (effective) FRP strain of 1000  $\mu\epsilon$  was suggested for the design of FRP strengthening solutions to ‘prevent’ slippage of the lapped bars. This value is in agreement with more recent test data indicating that FRP strains measured at peak capacity of rectangular and circular columns never exceed 8% and 15% of the ultimate elongation strain of carbon fibres ( $\epsilon_{fu}=15000 \mu\epsilon$ ), respectively (Tastani and Pantazopoulou 2006, Harajli 2009, Tastani and Pantazopoulou 2010). These results indicate that debonding of lapped bars typically occurs at low lateral strain values, which could be still sufficient to develop the full capacity of the lapped bars as evidenced by the tests summarised in Section 2.1.

FRP strains were found to increase with decreasing values of minimum clear concrete cover to bar diameter ( $c_{min}/d_b$ ) (Harajli 2008, Harajli and Dagher 2008). This can be attributed to the fact that, as the ratio  $c_{min}/d_b$  reduces, the formation of premature splitting cracks tend to mobilise the FRP confining action earlier. Tests results from lap-spliced columns indicate that the additional contribution of FRP confinement to the column capacity, with reference to the capacity of an unconfined specimen, is higher as the ratio  $c_{min}/d_b$  reduces (Harajli and Dagher 2008). Although the thickness of the concrete cover is crucial in bond splitting failures, its importance is frequently overlooked and actual measured covers from tested specimens are rarely reported, thus preventing accurate computations of bond strength.

### **3.4 Properties of FRP**

The use of a constant effective strain in the design of strengthening solutions for lap spliced members (see previous section) implies that stiff CFRP wraps could be expected to be more effective than AFRP/GFRP wraps because the former can mobilise higher confining pressures. However, very few studies have compared the effectiveness of different types of FRP confinement at improving the behaviour of lap-spliced columns (e.g. Haroun et al. 1999, Breña and Schlick 2007, Thermou and Pantazopoulou 2009). In these studies, lap-spliced columns confined with the same number of GFRP, AFRP or CFRP layers were capable of developing their full capacity. For similar values of axial stiffness  $n_f f_f E_f$ , the variation of the type of the FRP sheet does not affect the observed response (Thermou and Pantazopoulou 2009).

The influence of the type of fibre on bond strength has been also studied using a *bond strength approach*, but to a very limited extent. Kono et al. (1999, 2000) found that the use of CFRP strips (see Figure 2(d)) only increased marginally the bond strength of the bars when compared to AFRP strips. Hamad et al. (2004c) tested beam-splice specimens confined with either GFRP or CFRP sheets (Figure 4), and concluded that the type of fibre had no significant effect on the bond strength of the lapped bars. It should be noted, however, that similar confinement layouts and FRP axial stiffness were used. Ozden and Akpınar (2007) (see Figure 2(f)) indicated that the bond strength enhancement due to FRP confinement depended on the type of fibre, but a detailed analysis of their results leads to conflicting conclusions: a comparison between specimens with similar FRP axial stiffness shows that bar bond strength is only 2-6% higher in specimens wrapped with five GFRP layers than in those wrapped with two CFRP layers. The marginal bond enhancement difference between wrapping with five and two layers may be due to a lower effectiveness of the outer FRP layers in applying confinement compared to the inner layers, and also to possible slippage between such layers. In view of these inconsistencies, the effect of the type of FRP on anchorages and lap splices failing in bond splitting should be further investigated.

### **3.5 Concrete and bar properties**

Both the material properties of concrete and the geometry of the reinforcing bars play a major role in defining the bond-slip behaviour at the steel-concrete interface. Whilst the compressive ( $f_c$ ) and tensile ( $f_{ct}$ ) strength of concrete affect pullout and splitting bond strength, respectively, rib geometry and relative rib area of the bars are critical in ensuring the adequate transfer of bond forces through a rib bearing mechanism and are known to influence the extent of bar slippage (fib 2000).

In order to assess the effect of concrete compressive strength on the additional bond strength provided by FRP wraps, the experimental programme conducted by Hamad et al. (2004a) comprised normal and high-strength RC beam splice specimens (see Section 2.2.3 and Figure 4). Nominal concrete compressive strengths of  $f_c=27.6$  and 69.0 MPa were examined. As expected, the lapped bars used in high-strength beams mobilised a higher bond strength than that of normal-strength beams. Nonetheless, for equivalent test parameters and FRP layout, both groups of beams exhibited similar failure modes and bond strength enhancement values, thus suggesting that  $f_c$  has a relatively minor influence such enhancement.

Ozden and Akpınar (2007) studied the influence of different concrete strengths and bar diameters on the bond strength of anchorages using the specimens shown in Figure 2(f). Nominal concrete compressive strengths of  $f_c=20$  and 40 MPa were examined. The average bond strength enhancements after FRP wrapping were similar and ranged from 16% to 42% for concrete of 20 MPa, and from 18% to 40% for concrete of 40 MPa. The bond strength enhancement increased slightly with an increase in the bar diameter. For concrete of 20 MPa, average bond strength enhancements were 28%, 31% and 35% for  $d_b=12, 16$  and 26 mm, respectively. For the same bars anchored in concrete of 40 MPa, similar enhancements of 26%, 32% and 37% were obtained. The higher bond strength enhancement observed for the 16 and 26 mm bars (over the 12 mm bars) can be partially attributed to the larger contribution of FRP confinement on larger size bars, an effect which is also observed in lap splices confined with transverse steel stirrups (ACI Committee 408 2012). However, the large scatter observed in the bond strength results and the use of a constant  $c_{\min}/d_b$  ratio of 1.0 in the experimental study suggest that additional test data would be beneficial to assess the effect of bar diameter.

Tastani and Pantazopoulou (2010) also examined the influence of concrete properties on the bond strength of specially machined bars. Two different types of concrete were examined: a) concrete with tensile strength  $f_{ct}=2.05$  MPa and apparent porosity of 4.33%, and b) concrete with  $f_{ct}=2.30$  MPa and apparent porosity of 8.16%. The test results did not confirm any effect of these variables on the bond strength of the bars. As the machined bars had nominal rib heights of 0.5 and 1.1 mm and a rib face angle of  $90^\circ$ , the authors also investigated the effect of rib height on bond behaviour. Tastani and Pantazopoulou (2010) reported that, as expected, bars with higher ribs mobilised higher bond strengths due to enhanced rib bearing action, but led to smaller bar slip thus resulting in less ductile failures. Though insightful, these results relate to rib bar geometries that are not typical of commercial reinforcement, generally characterised by rib face angles ranging from  $30^\circ$  to  $50^\circ$ . Moreover, it is more convenient to compare the relative improvement that the FRP provides to confined specimens over unconfined specimens in terms of bond strength and ductility for different rib areas, rather than comparing the absolute bond improvement. It has been also argued that FRP-strengthened lap-spliced elements have highly variable properties of concrete in tension, but tests performed by the authors (Garcia et al. 2014, 2015) and by other researchers (Hamad et al. 2004a, 2004b, 2004c) on beam splice specimens

indicate that the FRP strengthening reduced the concrete variability in tension, thus providing more consistent bond strengths. In summary, the influence of concrete strength and bar characteristics on require further investigation.

### **3.6 Cross-section geometry and aspect ratio**

The concrete core of a FRP-confined circular column subjected to pure axial compression is effectively confined as the confining action is uniform over the cross section. Conversely, it is generally accepted that some regions of a rectangular cross section remain “unconfined” due to parabolic arching action (see Figure 7). Hence, reinforcing bars located in the shaded regions of Figure 7 are conservatively considered as unconfined, whereas those located at the corners are assumed as fully engaged. Several experimental studies have confirmed the lower effectiveness of FRP confinement at improving the response of lap-spliced columns with rectangular sections (Haroun et al. 1999, Saatcioglu and Elnabehy 2001, Haroun et al. 2003, Haroun and Elsanadedy 2005, Ghosh and Sheikh 2007). In an attempt to bypass this drawback, the shape of the cross sections (before applying the FRP) has been modified using oval concrete bolsters (Priestley et al. 1992, Priestley and Seible 1995), fast-curing cement (Saadatmanesh et al. 1997b) or epoxy grout (ElGawady et al. 2010) to form elliptical cross sections. Precast mortar blocks (Haroun et al. 2003, Haroun and Elsanadedy 2005) or steel plates (Chang et al. 2000) were also used to form semi-rounded cross sections. With the exception of the tests by Chang et al. (2000), studies showed that the overall behaviour of the oval-shaped columns was only slightly better than that of rectangular columns, and thus such shape modifications seem of little benefit.

Although the arching action shown in Figure 7 can develop in rectangular sections under pure axial compression (Mirmiran et al. 1998, Rochette and Labossière 2000), it may not develop in the same way during bond splitting failures when part of the concrete and the lapped bars are subjected to tension. Under this condition, FRP wraps are mainly expected to control the widening of splitting cracks forming on the tensioned side of the section. Indeed, it is the ability of the FRP reinforcement to control the development of splitting cracks that determines the effectiveness of the FRP strengthening at increasing the bond strength of “unconfined” bars, as confirmed experimentally by Ozden and Akpınar (2007), see Figure 2(f).

In an attempt to assess the effectiveness of CFRP reinforcement on the seismic performance of members with different cross section shapes, Harajli (2009) compared test results from rectangular (Harajli and Rteil 2004, Harajli and Dagher 2008) and circular (Harajli and Khalil 2008) lap-spliced columns. Harajli concluded that the section shape had no significant effect on column performance when CFRP was used for lap splice strengthening. However, a direct comparison of performance between the rectangular and circular columns discussed in Harajli (2009) is difficult due to the confinement effectiveness is different in such elements (only corner bars in square sections are effectively confined), as well as to the different test conditions and geometry in elevation. More refined standardised methodologies should be developed to enable comparisons of tests performed on specimens with different geometries.

In a column subjected to axial compression, the effectiveness of FRP confinement reduces as the aspect ratio of the cross section increases (aspect ratio=long column side/short column side). As a consequence, current FRP guidelines suggest ignoring the effect of confinement in rectangular columns with aspect ratios larger than 2 or face dimensions exceeding 900 mm (e.g. ACI 440.2R (2008) and CNR-DT 200 (2012)). It has been shown that CFRP-confined columns with lap splices in the range of  $l_b=30-35d_b$  and cross section aspect ratio of 2 can perform satisfactorily (Harajli and Rteil 2004, Harajli and Dagher 2008, ElGawady et al. 2010, ElSouri and Harajli 2011). Moreover, the use of one CFRP wrap was very effective at improving the behaviour of lap-spliced ( $l_b=30d_b$ ) shear walls with cross-section of 150×1200, i.e. an aspect ratio of 8 (Layssi et al. 2012). These results suggest that the aspect ratio limitation imposed by current FRP guidelines (that essentially assumes that FRP only confine the section corners) may be conservative for lap splice strengthening, and thus such limitation should be revised.

### **3.7 Damage level before FRP strengthening**

Only a few studies have investigated the use of FRP as a strengthening solution in lap-spliced damaged specimens. Saadatmanesh et al. (1997a) examined the effectiveness of concrete rehabilitation and FRP strengthening on circular and square columns that were damaged in a previous experimental study (Saadatmanesh et al. 1996). The rehabilitation included the removal and replacement of damaged concrete with new quick-setting concrete. After the rehabilitation, an oversized precured GFRP shell was wrapped around the column leaving a small gap between the shell and the concrete surface. The gap was filled with pressure-injected epoxy to provide active confinement. The rehabilitation and strengthening

enhanced the capacity of the columns by up to 38% with reference to the original 'as-built' specimens. In general, the rehabilitated and strengthened columns had lower flexural stiffness due to bond deterioration and damage accumulated during the initial tests.

Ilki et al. (2004) tested a damaged lap-spliced rectangular column with plain (smooth) bars rehabilitated and strengthened with six layers of CFRP. In this case, the low-strength damaged concrete ( $f_c=13.4$  MPa) was replaced using high-strength epoxy mortar with a compressive strength of 50 MPa. The rehabilitation and subsequent strengthening enhanced the capacity of the column by 34% in comparison to its original capacity. Moreover, both capacity and ductility were improved considerably with reference to those of an identical undamaged specimen. Ilki et al. (2004) also concluded that the level of pre-damage had no significant adverse effect on the performance of the rehabilitated and strengthened specimen, but they also suggest performing more tests to draw more general conclusions. However, the individual contribution of the rehabilitation solution and that of the CFRP strengthening is unclear.

Thermou and Pantazopoulou (2009) tested previously damaged square columns (Syntzirma and Pantazopoulou 2006) after strengthening. In this testing programme, the damaged concrete at the splice zone was not rehabilitated, and GFRP and CFRP wraps with similar axial stiffness were used. The adopted strengthening solutions enhanced the capacity of the columns by a minimum of 2% and up to 55% in comparison to the original specimens. The limited enhancement in capacity was attributed to bar yielding promoted by the use of closely spaced internal steel stirrups (spacing=70 mm) and the relatively long lap length used in some of the columns ( $l_b=36d_b$ ).

The results from the aforementioned studies indicate that the effectiveness of an FRP strengthening solution depends heavily on the extent and quality of rehabilitation of the concrete around the lap splice zone. Overall, the influence of the initial level of damage is difficult to assess due to the limited number of test results available in the literature, but also due to the different strengthening objectives between experimental programmes. As a consequence, the conclusions of these studies may not be easily generalised.

### 3.8 Other parameters

Other parameters not thoroughly investigated (thus conclusions are difficult to draw) but available in the literature are:

- (a) **Type of load and load path.** These include the influence of dynamic load on lap splices using shake table tests, partially spliced columns (50%) subjected to pseudo-dynamic tests PsD (Chung et al. 2008), quasi-static cyclic tests on repaired and FRP-strengthened lap-spliced square columns using a near-field earthquakes (Thermou and Pantazopoulou 2009), and cyclic fatigue load (Alyousef et al. 2015, Alyousef et al. 2016).
- (b) **Use of lap splices with plain (smooth) bars.** The activation of the passive confining action from FRP wraps relies on concrete dilation produced by the bar ribs reacting against the surrounding concrete. Consequently, FRP are less effective at enhancing the performance of RC columns with lap-spliced plain bars (Bousias et al. 2004, Ilki et al. 2004, Yalçin and Kaya 2004, Bousias et al. 2007).
- (c) **Corrosion of reinforcing bars.** Significant corrosion can deteriorate the bond strength between bars and concrete. However, provided the failure is dominated by cover splitting, the bond behaviour of corroded anchorages and lap splices can still be effectively enhanced through externally bonded FRP reinforcement around columns (Aquino and Hawkins 2007), as well as eccentric pullout specimens with L-shaped CFRP wraps (Soudki and Sherwood 2003), concentric pullout specimens confined with CFRP sheets (Papakonstantinou et al. 2011) (similar to those shown in Figure 2(c)-(d)), damaged beam-end specimens with or without low-strength mortar rehabilitation and strengthened with U-shaped CFRP wraps (Tastani and Pantazopoulou 2007), beam anchorage specimens (Craig and Soudki 2005) wrapped with U-shaped CFRP sheets, and beam splice specimens wrapped with U-shaped CFRP sheets (Shihata and Soudki 2012).

## 4 Predictive models and design guidelines

Table 1 summarises the predictive models available in the literature for FRP strengthening of RC members with substandard splices. The models are classified as a) design models, and b) bond strength enhancement models, and their main features and limitations are discussed.

#### 4.1 Design-oriented models

In these models, the FRP thickness required to strengthen the lapped zone is computed directly using equations derived from test results on circular and rectangular column specimens.

Priestley and co-workers (Priestley et al. 1992, Priestley and Seible 1995, Seible et al. 1997) proposed the first model for FRP strengthening of columns with substandard lapped bars (see model 1 in Table 1). The confining stress ( $f_l$ ) required to develop the tensile strength of the bar is computed using a frictional resistant approach that assumes a constant shear stress along potential splitting planes forming around a lapped bar. Lap splice failure is prevented by limiting the FRP strains to an effective strain  $\varepsilon_{fe}=1000 \mu\varepsilon$ , a value associated to the onset of “significant” slip of lapped bars (Chai et al. 1991, Priestley et al. 1994). Although studies indicate that this model may lead to the use of very conservative amounts of FRP confinement (Harries et al. 2006, Harajli 2008, Harajli and Khalil 2008), it is still included in current guidelines for FRP strengthening (e.g. EN 1998-3 (2005), CNR DT-200 (2012)). Using experimental strain readings from tests on GFRP-strengthened lap-spliced circular columns, Youm et al. (2007) suggested reducing the conservativeness of model 1 by adopting a higher value of effective FRP strain,  $\varepsilon_{fe}=2000 \mu\varepsilon$  (see model 5 in Table 1), but this has not been adopted in existing guidelines.

On the basis of a drift-based design approach for confinement of columns with steel stirrups (Saatcioglu and Razvi 2002), Elnabelsy and Saatcioglu (2004) proposed model 2 to compute the thickness of FRP required to develop a predetermined drift demand ( $\delta$ ) in lap-spliced columns. In this model, the effective FRP strain is limited to  $\varepsilon_{fe}=2000 \mu\varepsilon$ . The applicability of the model is limited to columns under significant levels of axial load (see model 2 in Table 1).

Using Xiao and Ma (1997) bond-slip model for lap splices, Elsanadedy and Haraoun (2005) proposed model 3 to calculate the thickness of the FRP required to develop yielding of substandard lapped bars in circular columns. A main feature of this model is that the minimum lateral confining stress  $f_l$  provided by the FRP takes into account the bond strength contribution provided by the column concrete cover. However, the equation used to compute this contribution (taken from ACI 408.2R-92 (2005)) may overestimate the bond strength of small diameter bars, resulting in low or even negative  $f_l$  values for

typical lap splice lengths of substandard structures. In addition, the model also implies that the applied strengthening will lead to yielding of the bars, which may not happen if the bars pullout.

Hawkins and co-workers (Hawkins et al. 2000, Aquino and Hawkins 2007) suggested using model 4 to compute the thickness of FRP required to strengthen columns with non-contact lap-splices. The model assumes that a shearing plane with given crack width develops between the starter bars and the longitudinal column bars. Accordingly, sufficient shear stress ( $v_{ci}$ ) should act over the failure surface to develop the full tensile strength of the starter bars before a bond failure occurs. The confining stress provided by the FRP should be equal to the normal compressive stress ( $f_{ci}$ ) that enables the development of the stress  $v_{ci}$ , computed according to the model by Vecchio and Collins (1986). Hawkins and co-workers indicated that the use of their model would result in more economical design solutions than those given by the FHWA (2006) retrofitting guidelines.

As all predictive models previously discussed were developed for circular and rectangular columns with specific geometries, they may not be easily generalised to account for other cross section geometries. Models adopting a general bond approach independent of the cross section geometry, however, are available in the literature and are discussed below.

## 4.2 Bond strength models

The models described in the following compute the total bond strength of the anchorages and lapped bars as the sum of the contributions from concrete cover, and the bond strength enhancement provided by the FRP reinforcement ( $\Delta\tau_{spl}$  in Figure 8).

Based on test results from the beam-end specimens shown in Figure 2(c)-(d), Kono et al. (1999, 2000) modified a bond equation originally developed for internal steel confinement (Fujii and Morita 1983) and proposed computing  $\Delta\tau_{spl}$  using model 6 in Table 1. In this model, the effect of the strengthening on bond strength is independent of the FRP strains. The nonlinear equation proposed by the authors follows the trend of the experimental results and suggests that the effectiveness of the external confinement reduces for FRP reinforcement ratios ( $\rho_f$ ) higher than 0.15%. The applicability of the model is limited to the maximum FRP reinforcement ratio examined in the experiments,  $\rho_f=0.35\%$ .

Hamad and co-workers (2004a, 2004b, 2004c, 2006) proposed model 7 based on calibration with limited test results from RC beam splice specimens (Figure 4). The model is equivalent to that suggested by Orangun et al. (1975, 1977) to compute the additional bond strength provided by steel stirrups on lapped bars in RC beams. The influence of the FRP wraps on the bond strength of lapped bars is accounted for through an effective stress ( $f_{fe}$ ) calculated according to the ACI 440.2R (2008) guidelines for shear strengthening. According to model 7, the bond strength enhancement due to the FRP reinforcement increases linearly with increasing amounts of FRP.  $\Delta\tau_{spl}$  is limited to  $0.25\sqrt{f_c}$  to reflect the fact that the use of additional FRP wraps cannot lead to further enhancement of the bond strength as failure is dominated by pullout (see dashed line in Figure 8). The same limiting value was proposed by Orangun et al. for internal steel stirrups.

Using the experimental results of the beams tested by Hamad and co-workers (2004a, 2004b, 2004c, 2006), Harajli et al. (2004) proposed computing  $\Delta\tau_{spl}$  using an equivalent area of FRP reinforcement to account for the different elastic modulus of steel stirrups and FRP (model 8 in Table 1). As FRP confinement controlled the widening of splitting cracks more effectively than internal steel stirrups, Harajli et al. limited  $\Delta\tau_{spl}$  to  $0.40\sqrt{f_c}$  (Harajli et al. 2004, Harajli 2007).

Ozden and Akpınar (2007) developed model 9 on the basis of the thick-walled cylinder analogy proposed by Tepfers (1973). Accordingly, the FRP wraps are assumed to exert a lateral confining stress  $f_l$  over a thick-walled cylinder of diameter  $3d_b$ . To compute  $f_l$ , the model adopts an effective FRP strain that depends on the concrete surface strain at bond failure ( $\varepsilon_{co}$ ), bar diameter and FRP axial stiffness. Model 9 was calibrated using test results from beam-end specimens (see Figure 2(f)) and was only validated for bars with very short anchorage lengths and with a clear concrete cover equal to the bar diameter ( $c=d_b$ ).

Model 10 was developed by Tastani and Pantazopoulou (2008, 2010) adopting the ACI 318 (2011) frictional model for bond and a thick-walled cylinder analogy. The model assumes the use of an effective FRP strain, which is determined as a function of the clear concrete cover, bar diameter and radial displacement produced by concrete dilation due to rib bearing action. The radial displacement is considered as half the bar slip based on tests on splitting-prone pullout specimens with a short bonded length  $l_b=8.33d_b$  (Lura et al. 2002). An important improvement in this model is the recognition of the

strong interaction between bar slippage and FRP strains. However, to date such interaction has not been examined extensively on large-scale lap-spliced members (Harajli and Dagher 2008).

Based on modifications of the bond strength equations for internal steel confinement (Zuo and Darwin 2000, Lettow and Eligehausen 2006), Bournas and Triantafillou (2011) proposed two models to calculate  $\Delta\tau_{spl}$ . In these models, the effective strain developed in the FRP confinement (thus the associated  $\Delta\tau_{spl}$ ) reduce with the increase of the lap length to bar diameter ratio ( $l_b/d_b$ ), and is taken as zero for “long” lap lengths  $l_b > 55d_b$ . As no studies appear to have examined in detail the development of FRP strains for different ratios  $l_b/d_b$ , further experimental data are deemed necessary to validate this assumption. Model 11 in Table 1 was found to predict more accurately FRP strain readings from other tests on columns (Harajli and Dagher 2008, ElGawady et al. 2010).

More recently, Garcia et al. (2014, 2015) proposed a practical strain control approach (model 12 in Table 1) to calculate the bond strength enhancement due to FRP confinement. The effect of the CFRP confinement is considered through an additional confining pressure  $f_o$  assumed to act over a split cross sectional area equal to  $(c_{min(x,y)} + d_b) \cdot l_b$ , as shown in Figure 9. The model was calibrated using experimental data from normal-strength FRP-strengthened beams with different lap splice lengths tested by the authors (as described in Section 2.2.3), and by Hamad et al. (2006). Figure 10 compares the predictions of model 12 with the experimental results from the above beam tests. Despite the different test parameters and lap length examined in these different experimental programmes, it is evident that the proposed equation matches consistently the trend of results. Moreover, previous research (Garcia et al. 2014, Garcia et al. 2015) has shown that, compared to existing strain control models (Hamad and co-workers (2004a, 2004b, 2004c, 2006), Harajli et al. (2004), Bournas and Triantafillou (2011)), model 12 predicts more consistently the bond strength enhancement due to FRP confinement, as well as the actual FRP strains mobilised at bond failure.

The accuracy of model 12 at predicting the bond strength enhancement of lapped or anchored steel bars is further assessed using an extended test data set collected from the existing literature. The following criteria were used to select the data:

- The tests were carried out on beam splice or pullout specimens with lap/anchorage lengths in the range of  $l_b=5-25d_b$
- The lapped/anchored bar remained elastic during the tests.
- The experimental maximum bar stress (or bond strength) mobilised in the lapped/anchored bars was explicitly reported, and this value could be assumed as uniform over the lap/anchorage.
- The FRP properties were either reported, or these could be found in the manufacturers' technical data sheets.
- Minimum clear concrete cover was reported and complies with the applicability limits of the proposed model 12, i.e. approximately  $0.8 \leq c_{min}/d_b \leq 2.0$ .

The above criteria led to a dataset of 35 beam splice specimens and 92 pullout specimens, which are summarised in Table 2 and Table 3, respectively. In this tables,  $\tau_{spl,t}$  is the bond strength mobilised in the test,  $\Delta\tau_{spl,t}$  is the bond strength enhancement due to the FRP confinement only, and the rest of the variables are as defined in Table 1. The value  $\Delta\tau_{spl,t}$  was calculated as the difference between the bond strength of FRP-confined specimens, and that of corresponding unconfined control specimens. The tables also compare the experimental normalised bond strength enhancement ( $\Delta\tau_{spl,t}/f_{cm}^{1/2}$ ) with the analytical predictions calculated with model 12 ( $\Delta\tau_{spl}/f_{cm}^{1/2}$ ). For the beam splice specimens (Table 2), model 12 predicts the results with a mean Test/Prediction ratio (T/P) of 1.13 and a standard deviation (StdDev) of 0.43. For the pullout specimens included in Table 3, such values are T/P=1.36 and StdDev=0.80. Whilst the model predicts conservatively the experimental results, it also yields a relatively larger scatter, which was somehow expected given the large variability of concrete in tension, as well as the different test programmes considered in the assessment.

It should be mentioned that the majority of the models described above were calibrated using results from a limited number of tests. However, provided the bond strength contributions from concrete cover and steel stirrups are known, these models seem to accurately determine the types of bond failure observed experimentally (either splitting or pullout, see Figure 8) and that typically dominate the behaviour of substandard lap-spliced members strengthened with FRP. This implies that the amount of FRP required to develop the full capacity of the lapped bars can be readily computed, thus resulting in a more efficient use of FRP reinforcement material and more economical strengthening solutions. The variety of test

specimens' geometries and set-ups that have been used by researchers to date, however, prevents compiling a comprehensive database of experimental results and does not allow for more accurate calibration of existing predictive models and the development of new improved models.

### 4.3 Guidelines for FRP strengthening

Few guidelines provide specific recommendations for the strengthening of substandard lap-spliced columns with externally bonded FRP confinement. For circular columns, the Eurocode 8 Part 3 (2005), Italian CNR-DT 200 (2012) and Turkish Earthquake Design Code TEC 2007 (2007) suggest computing the thickness of the FRP confinement using model 1 in Table 1. Both guidelines also extend the use of the same model for rectangular columns implementing the following modifications:

a) In EN 1998-3, the section width  $b_w$  of the rectangular column replaces the diameter  $D$ . The confining stress  $f_l$  is 'reduced' by a shape factor  $k_s$  defined by Eq. (1) (Mirmiran et al. 1998):

$$k_s = \frac{2r_c}{b_w} \quad (1)$$

where  $r_c$  is the corner radius defined in Figure 7.

b) In CNR-DT 200 and TEC 2007, the larger column side replaces the diameter  $D$ . In this case,  $f_l$  is 'reduced' using a factor  $k_H$  (Eq. (2)) to account for the arching effect shown in Figure 7 (Restrepo and De Vito 1996):

$$k_H = 1 - \frac{b'^2 + d'^2}{3A_g} \quad (2)$$

where  $b'$  and  $d'$  are defined in Figure 7, and  $A_g$  is the gross sectional area of the column.

Whilst the above mentioned codes follow a *capacity-ductility approach*, the Japanese AIJ guidelines (2002) adopt a *bond strength approach* to compute the contribution of FRP reinforcement to bond strength using model 13 in Table 1, which is a modified version of the equation originally developed by Fujii and Morita (1983) for internal steel confinement.

Finally, the Greek Code of Structural Interventions (EPPO 2012) for RC buildings uses a frictional approach (model 14 in Table 1) to design the thickness of the FRP strengthening. The effective FRP

strains  $\varepsilon_{fe}$  are calculated using the development of cracks due to “an acceptable amplitude” of slip  $s_d$  in the lapped bars. The code proposes values  $s_d=0.3$  mm for structures with Performance Level A (Immediate Occupancy) and  $s_d=0.4$  mm for levels B and C (Life Protection and Collapse Prevention, respectively). The model considers a design limit state as implied by the inclusion of partial safety factors. Whilst the Greek code is adequately progressing towards a general *bond strength approach*, the adopted model suggests ignoring the contribution of the concrete cover around the lap ( $\lambda_s=0$ ), which may actually account for most of the existing bond strength of the lap as demonstrated experimentally (e.g. Hamad et al. 2004a, 2004b, 2004c, Hamad and Rteil 2006, Garcia et al. 2014, 2015).

The comprehensive literature survey in this study indicates that, despite the large number of studies available in the literature, existing codes of practice have yet to include more general bond strength approach models. However, it is envisaged that future revisions the *fib* Bulletin 14 and Eurocode 8 Part 3 (both currently under revision) will include such type of models (e.g. Pantazopoulou et al. 2015).

## 5 Summary and conclusions

This article presented a literature survey on substandard lap-spliced members strengthened with external FRP reinforcement. To date, the majority of the studies have adopted a *capacity-ductility approach* to assess the effectiveness of this strengthening method, focusing on the general performance and enhancements in the capacity and/or ductility of FRP-strengthened columns over original substandard specimens. However, the lack of uniformity of the tested specimens does not enable direct comparisons of results between different experimental programmes. Based on this experimental methodology, some design models were proposed for the FRP strengthening of circular and rectangular columns, but such models may not be easily generalised to account for other cross section geometries.

In contrast, some studies adopt a *bond strength approach* to examine the basic behaviour of anchorages and lap splices using standard specimens recommended in state-of-the art reports on bond. The effectiveness of the FRP strengthening is usually evaluated by comparing the observed bond strength of unstrengthened and FRP-strengthened specimens. Predictive models adopting a general bond approach are independent of the cross section geometry and compute the total bond strength as the sum of the

contributions from concrete cover and internal steel stirrups (if any), and the bond strength enhancement provided by the FRP reinforcement. Whilst these models were calibrated using results from a limited number of tests, they allow determining the amount of FRP required to develop the full capacity of the lapped bars, thus resulting in a more efficient use of FRP reinforcement material and more economical strengthening solutions. It is envisaged that future revisions the *fib* Bulletin 14 and Eurocode 8 Part 3 (both currently under revision will include *bond strength approaches* models for design and assessment.

Additional research is considered necessary to provide further understanding of the following aspects:

- More results from tests on standard specimens (e.g. beam-end or beam splice specimens) with different lap splice lengths would provide instrumental insight into the bond behaviour of FRP-confined members. In particular, results from beam splice specimens can provide suitable bulk data to develop and calibrate more accurate bond strength models.
- As the effectiveness of FRP reinforcement at enhancing the bond strength of a lap splice is limited by bar pullout, suggested values for the maximum achievable bond strength enhancement need to be corroborated.
- The interaction between bar slippage and FRP strains on full-scale lap-spliced members and the influence of different ratios  $l_b/d_b$  on the development of FRP strains need to be investigated.
- To date, it is unclear how the different concrete and bar properties, as well as the type of FRP material with different axial stiffnesses, affect the bond strength of anchorages and lap splices in FRP-strengthened members.
- The effectiveness of FRP strengthening at improving the behaviour of lap-spliced members with rectangular cross sections and different aspect ratios needs to be studied using more standardised tests to enable direct comparisons.
- The effect of type and rate of loading on the behaviour of lapped bars has not been thoroughly investigated.

## References

Aboutaha, R.S., Engelhardt, M.D., Jirsa, J.O. and Kreger, M.E. (1996). "Retrofit of concrete columns with inadequate lap splices by the use of rectangular steel jackets", *Earthquake Spectra*, Vol. 12, No. 4, pp. 693-714.

- ACI Committee 318 (2011). ACI 318-11 Building Code Requirements for Structural Concrete and Commentary, American Concrete Institute, Farmington Hills, MI, USA .
- ACI Committee 408 (2005). 408.2R-92 Bond under Cyclic Loads (Reapproved 2005), American Concrete Institute, Farmington Hills, MI, USA.
- ACI Committee 408 (2012). 408R-03 Bond and Development of Straight Reinforcing Bars in Tension (Reapproved 2012), American Concrete Institute, Farmington Hills, MI, USA.
- ACI Committee 440 (2008). 440.2R-08 Guide for the Design and Construction of Externally Bonded FRP Systems for Strengthening Concrete Structures, American Concrete Institute, Farmington Hills, MI, USA.
- AIJ (2002). Design and construction guideline of continuous fiber reinforced concrete (in Japanese), Architectural Institute of Japan, Tokyo, Japan.
- Alyousef, R., Topper, T. and Al-Mayah, A. (2015). "Effect of FRP Wrapping on Fatigue Bond Behavior of Spliced Concrete Beams", *Journal of Composites for Construction*, Vol. 20, No. 1, pp. 04015030.
- Alyousef, R., Topper, T. and Al-Mayah, A. (2016). "Effect of the thickness of concrete cover on the fatigue bond strength of GFRP wrapped and non-wrapped reinforced concrete beams containing a lap splice", *Structures*, Vol. 6, No. May, pp. 1-8.
- Aquino, W. and Hawkins, N.M. (2007). "Seismic retrofitting of corroded reinforced concrete columns using carbon composites", *ACI Structural Journal*, Vol. 104, No. 3, pp. 348-356.
- Bournas, D.A. and Triantafyllou, T.C. (2011). "Bond strength of lap-spliced bars in concrete confined with composite jackets", *Journal of Composites for Construction*, Vol. 15, No. 2, pp. 156-167.
- Bousias, S., Spathis, A.-L. and Fardis, M.N. (2004). "Seismic retrofitting of columns with lap-splices through CFRP jackets", Proc. of the 13th World Conference on Earthquake Engineering, Vancouver, BC, Canada, paper no. 765 (in CD-ROM);
- Bousias, S., Spathis, A.L. and Fardis, M.N. (2007). "Seismic retrofitting of columns with lap spliced smooth bars through FRP or concrete jackets", *Journal of Earthquake Engineering*, Vol. 11, No. 5, pp. 653-674.
- Bousias, S.N., Spathis, A.-L. and Fardis, M.N. (2006). "Concrete or FRP jacketing of columns with lap splices for seismic rehabilitation", *Journal of Advanced Concrete Technology*, Vol. 4, No. 3, pp. 431-444.
- Breña, S.F. and Schlick, B.M. (2007). "Hysteretic behavior of bridge columns with FRP-jacketed lap splices designed for moderate ductility enhancement", *Journal of Composites for Construction*, Vol. 11, No. 6, pp. 565-574.
- BSI (2005). BS EN 1998-3 Eurocode 8 Design of structures for earthquake resistance Part 3: Assessment and retrofitting of buildings, British Standards Institution, London, UK.
- Chai, Y.H., Priestley, M.J.N. and Seible, F. (1991). "Seismic retrofit of circular bridge columns for enhanced flexural performance", *ACI Structural Journal*, Vol. 88, No. 5, pp. 572-584.
- Chang, K., Chung, L., Lee, B., Tsai, K., Hwang, J. and Hwang, S. (2000). Seismic retrofit study of RC bridge columns, International Training Program for Seismic Design of Building Structures, National Center for Research on Earthquake Engineering (NCREE), Taiwan.
- Chang, K.C., Liu, K.Y. and Chang, S.B. (2001). "Seismic retrofit study of RC rectangular bridge columns lap-spliced at the plastic hinge zone", International Conference on FRP Composites in Civil Engineering, Hong Kong, China.
- Chung, Y.-S., Park, C.K. and Meyer, C. (2008). "Residual seismic performance of reinforced concrete bridge piers after moderate earthquakes", *ACI Structural Journal*, Vol. 105, No. 1, pp. 87-95.
- CNR (2012). CNR-DT 200 R1/2012 Istruzioni per la Progettazione, l'Esecuzione ed il Controllo di Interventi di Consolidamento Statico mediante l'utilizzo di Compositi Fibrorinforzati - Materiali, strutture di c.a. e di c.a.p., strutture murarie, Consiglio Nazionale delle Ricerche, Roma, Italia.
- Craig, B.C. and Soudki, K.A. (2005). "Post-repair performance of corroded bond critical RC beams repaired with CFRP", SP230: Proc. of the 7th International Symposium on Fiber-Reinforced (FRP) Polymer Reinforcement for Concrete Structures, Kansas City, MO, USA, paper no. 33.
- ElGawady, M., Endeshaw, M., McLean, D. and Sack, R. (2010). "Retrofitting of rectangular columns with deficient lap splices", *Journal of Composites for Construction*, Vol. 14, No. 1, pp. 22-35.
- Elnabehly, G. and Saatcioglu, M. (2004). "Design of FRP jackets for seismic retrofit of circular concrete columns", *Emirates Journal of Engineering Research*, Vol. 9, No. 2, pp. 65-69.
- Elsanadedy, H.M. and Haroun, M.A. (2005). "Seismic design criteria for circular lap-spliced reinforced concrete bridge columns retrofitted with fiber-reinforced polymer jackets", *ACI Structural Journal*, Vol. 102, No. 3, pp. 354-362.
- ElSouri, A.M. and Harajli, M.H. (2011). "Seismic repair and strengthening of lap splices in RC columns: carbon fiber-reinforced polymer versus steel confinement", *Journal of Composites for Construction*, Vol. 15, No. 5, pp. 721-731.
- EPPO (2012). Code of Structural Interventions (Final Harmonized Text), Earthquake Planning and Protection Organization of Greece, Greece.
- Eshghi, S. and Zanjanizadeh, V. (2008). "Retrofit of slender square reinforced concrete columns with glass fiber-reinforced polymer for seismic resistance", *Iranian Journal of Science and Technology Transaction B-Engineering*, Vol. 32, No. 5B, pp. 437-450.
- FHWA (2006). Seismic Retrofitting Manual for Highway Structures Part 1 - Bridges. Publication No. FHWA-HRT-06-032 - US Department of Transportation - Federal Highway Administration, McLean, USA.

- fib (2000). Bulletin 10 Bond of reinforcement in concrete - State-of-art report, Fédération Internationale du Béton, Lausanne, Switzerland.
- fib (2001). Bulletin 14 Design and use of externally bonded fibre reinforced polymer reinforcement (FRP EBR) for reinforced concrete structures, Fédération Internationale du Béton, Lausanne, Switzerland.
- fib (2010). Bulletin 55 Model Code Volume 1. First complete draft, Fédération Internationale du Béton, Lausanne, Switzerland.
- Fujii, S. and Morita, S. (1983). "Splitting bond capacity of deformed bars Part 2 - A proposed ultimate strength equation for splitting bond failure", *Transactions of the Architectural Institute of Japan, Architectural Institute of Japan*, Vol. No. 324, pp. 45-53.
- Garcia, R., Helal, Y., Pilakoutas, K. and Guadagnini, M. (2014). "Bond behaviour of substandard splices in RC beams externally confined with CFRP", *Construction and Building Materials*, Vol. 50, No., pp. 340-351.
- Garcia, R., Helal, Y., Pilakoutas, K. and Guadagnini, M. (2015). "Bond strength of short lap splices in RC beams confined with steel stirrups or external CFRP", *Materials and Structures*, Vol. 48, No. 1-2, pp. 277-293.
- Ghosh, K.K. and Sheikh, S.A. (2007). "Seismic upgrade with carbon fiber-reinforced polymer of columns containing lap-spliced reinforcing bars", *ACI Structural Journal*, Vol. 104, No. 2, pp. 227-236.
- Hage Ali, A.Y. (2003). Effect of fiber reinforced polymers on confinement of anchorage zones, MSc thesis, Department of Civil and Environmental Engineering, Faculty of Engineering and Architecture, the American University of Beirut, Beirut, Lebanon.
- Hamad, B.S. and Najjar, S. (2002). "Evaluation of the role of transverse reinforcement in confining tension lap splices in high strength concrete", *Materials and Structures*, Vol. 35, No. 4, pp. 219-228.
- Hamad, B.S. and Rteil, A.A. (2006). "Comparison of roles of FRP sheets, stirrups, and steel fibers in confining bond critical regions", *Journal of Composites for Construction*, Vol. 10, No. 4, pp. 330-336.
- Hamad, B.S., Rteil, A.A., Salwan, B.R. and Soudki, K.A. (2004a). "Behavior of bond-critical regions wrapped with fiber-reinforced polymer sheets in normal and high-strength concrete", *Journal of Composites for Construction*, Vol. 8, No. 3, pp. 248-257.
- Hamad, B.S., Rteil, A.A. and Soudki, K.A. (2004b). "Bond strength of tension lap splices in high-strength concrete beams strengthened with glass fiber reinforced polymer wraps", *Journal of Composites for Construction*, Vol. 8, No. 1, pp. 14-21.
- Hamad, B.S., Soudki, K.A., Harajli, M.H. and Rteil, A.A. (2004c). "Experimental and analytical evaluation of bond strength of reinforcement in fiber-reinforced polymer-wrapped high-strength concrete beams", *ACI Structural Journal*, Vol. 101, No. 6, pp. 747-754.
- Harajli, M.H. (2006). "Effect of confinement using steel, FRC, or FRP on the bond stress-slip response of steel bars under cyclic loading", *Materials and Structures*, Vol. 39, No. 6, pp. 621-634.
- Harajli, M.H. (2007). "Numerical bond analysis using experimentally derived local bond laws: A powerful method for evaluating the bond strength of steel bars", *Journal of Structural Engineering-ASCE*, Vol. 133, No. 5, pp. 695-705.
- Harajli, M.H. (2008). "Seismic behavior of RC columns with bond-critical regions: Criteria for bond strengthening using external FRP jackets", *Journal of Composites for Construction*, Vol. 12, No. 1, pp. 69-79.
- Harajli, M.H. (2009). "Bond strengthening of lap spliced reinforcement using external FRP jackets: An effective technique for seismic retrofit of rectangular or circular RC columns", *Construction and Building Materials*, Vol. 23, No. 3, pp. 1265-1278.
- Harajli, M.H. and Dagher, F. (2008). "Seismic strengthening of bond-critical regions in rectangular reinforced concrete columns using fiber-reinforced polymer wraps", *ACI Structural Journal*, Vol. 105, No. 1, pp. 68-77.
- Harajli, M.H., Hamad, B.S. and Rteil, A.A. (2004). "Effect of confinement on bond strength between steel bars and concrete", *ACI Structural Journal*, Vol. 101, No. 5, pp. 595-603.
- Harajli, M.H. and Khalil, Z. (2008). "Seismic FRP retrofit of bond-critical regions in circular RC columns: Validation of proposed design methods", *ACI Structural Journal*, Vol. 105, No. 6, pp. 760-769.
- Harajli, M.H. and Rteil, A.A. (2004). "Effect of confinement using fiber-reinforced polymer or fiber-reinforced concrete on seismic performance of gravity load-designed columns", *ACI Structural Journal*, Vol. 101, No. 1, pp. 47-56.
- Haroun, M.A. and Elsanadedy, H.M. (2005). "Fiber-reinforced plastic jackets for ductility enhancement of reinforced concrete bridge columns with poor lap-splice detailing", *Journal of Bridge Engineering*, Vol. 10, No. 6, pp. 749-757.
- Haroun, M.A., Feng, M.Q., Bhatia, H., Baird, K. and Elsanadedy, H. (1999). Structural qualification testing of composite-jacketed circular and rectangular bridge columns. Final report to the California Department of Transportation, Report RTA - 59A0005, Dept. of Civil and Environmental Engineering, University of California-Irvine, USA.
- Haroun, M.A., Mosallam, A.S., Feng, M.Q. and Elsanadedy, H.M. (2003). "Experimental investigation of seismic repair and retrofit of bridge columns by composite jackets", *Journal of Reinforced Plastics and Composites*, Vol. 22, No. 14, pp. 1243-1268.
- Harries, K.A., Ricles, J.R., Pessiki, S. and Sause, R. (2006). "Seismic retrofit of lap splices in nonductile square columns using carbon fiber-reinforced jackets", *ACI Structural Journal*, Vol. 103, No. 6, pp. 874-884.
- Hawkins, N.M., Gamble, W.L., Shkurti, F. and Lin, Y. (2000). "Seismic strengthening of inadequate length lap splices", Proc. of the 12th World Conference on Earthquake Engineering, Auckland, New Zealand, paper no. 1755.

- Ilki, A., Tezcan, A., Koc, V. and Kumbasar, N. (2004). "Seismic retrofit of non-ductile rectangular reinforced concrete columns by CFRP jacketing", Proc. of the 13th World Conference on Earthquake Engineering Vancouver, BC, Canada, paper no. 2236 (in CD-ROM);
- Kim, I., Jirsa, J.O. and Bayrak, O. (2011). "Use of carbon fiber-reinforced polymer anchors to repair and strengthen lap splices of reinforced concrete columns", *ACI Structural Journal*, Vol. 108, No. 5, pp. 630-640.
- Kono, S., Inazumi, M. and Kaku, T. (1997). "Bond splitting behavior of reinforced concrete members confined with CFRP sheets", Proc. of the 3rd International Symposium on Non-Metallic (FRP) Reinforcement for Concrete Structures (FRPRCS-3), Vol. 2, Sapporo, Japan.
- Kono, S., Matsuno, K. and Kaku, T. (1999). "Experimental study on bond-slip behavior of longitudinal bars in reinforced concrete beams confined with fiber reinforced polymer sheets", SP188: Proc. of the 4th International Symposium - Fiber Reinforced Polymer Reinforcement for Reinforced Concrete Structures, ACI Committee 440 and Joint ACI-ASCE Committee 423 Baltimore, MD, USA.
- Kono, S., Matsuno, K. and Kaku, T. (2000). "Bond-slip behavior of longitudinal reinforcing bars confined with FRP sheets", Proc. of the 12th World Conference on Earthquake Engineering Auckland, New Zealand, paper no. 0642.
- Lam, L. and Teng, J.G. (2003). "Design-oriented stress-strain model for FRP-confined concrete in rectangular columns", *Journal of Reinforced Plastics and Composites*, Vol. 22, No. 13, pp. 1149-1186.
- Layssi, H., Cook, W.D. and Mitchell, D. (2012). "Seismic response and CFRP retrofit of poorly detailed shear walls", *Journal of Composites for Construction*, Vol. 16, No. 3, pp. 332-339.
- Lettow, S. and Eligehausen, R. (2006). Formulation of application rules for lap splices in the new Model Code, fib Task Group 4.5 "Bond models", Stuttgart, Germany.
- Lura, P., Plizzari, G.A. and Riva, P. (2002). "3D finite-element modelling of splitting crack propagation", *Magazine of Concrete Research*, Vol. 54, No. 6, pp. 481-493.
- Ma, R. and Xiao, Y. (1999). "Seismic retrofit and repair of circular bridge columns with advanced composite materials", *Earthquake Spectra*, Vol. 15, No. 4, pp. 747-764.
- Ma, R., Xiao, Y. and Li, K.N. (2000). "Full-scale testing of a parking structure column retrofitted with carbon fiber reinforced composites", *Construction and Building Materials*, Vol. 14, No. 2, pp. 63-71.
- Mirmiran, A., Shahawy, M., Samaan, M., Echary, H., Mastrapa, J. and Pico, O. (1998). "Effect of column parameters on FRP-confined concrete", *Journal of Composites for Construction*, Vol. 2, No. 4, pp. 175-185.
- Orangun, C., Jirsa, J.O. and Breen, J. (1975). The strength of anchor bars: A reevaluation of test data on development length and splices, Research Report 154-3F, Center for Highway Research, University of Texas at Austin. Austin, TX, USA.
- Orangun, C.O., Jirsa, J.O. and Breen, J.E. (1977). "Re-evaluation of test data on development length and splices", *Journal of the American Concrete Institute*, Vol. 74, No. 3, pp. 114-122.
- Ozden, S. and Akpınar, E. (2007). "Effect of confining FRP overlays on bond strength enhancement", *Construction and Building Materials*, Vol. 21, No. 7, pp. 1377-1389.
- Pantazopoulou, S., Tastani, S., Thermou, G., Triantafyllou, T., Monti, G., Bournas, D. and Guadagnini, M. (2015). "Background to European seismic design provisions for the retrofit of RC elements using FRP materials", *Structural Concrete*, DOI: 10.1002/suco.201500102.
- Papakonstantinou, C.G., Balaguru, P.N. and Auyeung, Y. (2011). "Influence of FRP confinement on bond behavior of corroded steel reinforcement", *Cement and Concrete Composites*, Vol. 33, No. 5, pp. 611-621.
- Priestley, M., Seible, F. and Chai, Y.H. (1992). Design guidelines for assessment retrofit and repair of bridges for seismic performance, Dept. of Applied Mechanics and Engineering Sciences, University of California, San Diego, USA.
- Priestley, M.J.N. and Seible, F. (1995). "Design of seismic retrofit measures for concrete and masonry structures", *Construction and Building Materials*, Vol. 9, No. 6, pp. 365-377.
- Priestley, M.J.N., Seible, F., Xiao, Y. and Verma, R. (1994). "Steel jacket retrofitting of reinforced-concrete bridge columns for enhanced shear strength - Part 2: Test results and comparison with theory", *ACI Structural Journal*, Vol. 91, No. 5, pp. 537-551.
- Restrepo, J. and De Vito, B. (1996). "Enhancement of the axial load carrying capacity of reinforced concrete columns by means of fiberglass-epoxy jacket", Proc. of the 2nd International Conference on Advanced Composite Materials in Bridges and Structures (ACMBS-2), Montreal, QC, Canada.
- Rochette, P. and Labossière, P. (2000). "Axial testing of rectangular column models confined with composites", *Journal of Composites for Construction*, Vol. 4, No. 3, pp. 129-136.
- Rteil, A.A., Soudki, K.A. and Topper, T.H. (2007). "Preliminary experimental investigation of the fatigue bond behavior of CFRP confined RC beams", *Construction and Building Materials*, Vol. 21, No. 4, pp. 746-755.
- Saadatmanesh, H., Ehsani, M.R. and Jin, L. (1996). "Seismic strengthening of circular bridge pier models with fiber composites", *ACI Structural Journal*, Vol. 93, No. 6, pp. 639-647.
- Saadatmanesh, H., Ehsani, M.R. and Jin, L. (1997a). "Repair of earthquake-damaged RC columns with FRP wraps", *ACI Structural Journal*, Vol. 94, No. 2, pp. 206-215.
- Saadatmanesh, H., Ehsani, M.R. and Jin, L. (1997b). "Seismic retrofitting of rectangular bridge columns with composite straps", *Earthquake Spectra*, Vol. 13, No. 2, pp. 281-304.
- Saatcioglu, M. and Elnabesy, G. (2001). "Seismic retrofit of bridge columns with CFRP jackets". International Conference of FRP Composites in Civil Engineering, Hong Kong, China.

- Saatcioglu, M. and Razvi, S.R. (2002). "Displacement-based design of reinforced concrete columns for confinement", *ACI Structural Journal*, Vol. 99, No. 1, pp. 3-11.
- Salwan, B.R. (2003). Behavior of bond critical regions wrapped with FRP sheets in normal strength concrete, Msc Thesis, American University of Beirut.
- Sause, R., Harries, K.A., Walkup, S.L., Pessiki, S. and Ricles, J.M. (2004). "Flexural behavior of concrete columns retrofitted with carbon fiber-reinforced polymer jackets", *ACI Structural Journal*, Vol. 101, No. 5, pp. 708-716.
- Schlick, B.M. and Breña, S.F. (2004). "Seismic rehabilitation of reinforced concrete bridge columns in moderate earthquake regions using FRP composites", Proc. of the 13th World Conference on Earthquake Engineering, Vancouver, BC, Canada, paper no. 508 (in CD-ROM).
- Seible, F., Priestley, M.J.N., Hegemier, G.A. and Innamorato, D. (1997). "Seismic retrofit of RC columns with continuous carbon fiber jackets", *Journal of Composites for Construction*, Vol. 1, No. 2, pp. 52-62.
- Seible, F., Priestley, M.J.N. and Innamorato, D. (1995). Earthquake Retrofit of Bridge Columns with Continuous Carbon Fiber Jackets. Volume II - Design Guidelines. Report No. ACTT-95/08, Advanced Composites Technology Transfer Consortium. La Jolla, CA University of California, San Diego, USA.
- Shihata, A. and Soudki, K. (2012). "Corroded tension lap-spliced RC beams with FRP wraps", Proc. of the 6th International Conference on Fiber Reinforced Polymer (FRP) Composites in Civil Engineering Rome, Italy, paper no. 01-453.
- Soudki, K. and Sherwood, T. (2003). "Bond behavior of corroded steel reinforcement in concrete wrapped with carbon fiber reinforced polymer sheets", *Journal of Materials in Civil Engineering*, Vol. 15, No. 4, pp. 358-370.
- Syntzirma, D. and Pantazopoulou, S. (2006). "Assessment of deformability of RC members with substandard details", Proc. of the 2nd International fib Congress, Naples, Italy.
- Tastani, S.P. and Pantazopoulou, S.J. (2006). "Bond of GFRP Bars in Concrete: Experimental Study and Analytical Interpretation", *Journal of Composites for Construction*, Vol. 10, No. 5, pp. 381-391.
- Tastani, S.P. and Pantazopoulou, S.J. (2007). "Behavior of corroded bar anchorages", *ACI Structural Journal*, Vol. 104, No. 6, pp. 756-766.
- Tastani, S.P. and Pantazopoulou, S.J. (2008). "Detailing procedures for seismic rehabilitation of reinforced concrete members with fiber reinforced polymers", *Engineering Structures*, Vol. 30, No. 2, pp. 450-461.
- Tastani, S.P. and Pantazopoulou, S.J. (2010). "Direct Tension Pullout bond test: Experimental Results", *Journal of Structural Engineering-ASCE*, Vol. 136, No. 6, pp. 731-743.
- TEC (2007). Specification for Buildings to be Built in Seismic Zones, Ministry of Public Works and Settlement, Official Gazette, Government of the Republic of Turkey, Turkey.
- Tepfers, R. (1973). A theory of bond applied to overlapped tensile reinforcement splices for deformed bars, PhD, Publication 73:2, Division of Concrete Structures, School of Civil Engineering, Chalmers University of Technology, Sweden.
- Thermou, G.E. and Pantazopoulou, S.J. (2009). "Fiber-reinforced polymer retrofitting of predamaged substandard rc prismatic members", *Journal of Composites for Construction*, Vol. 13, No. 6, pp. 535-546.
- Vecchio, F.J. and Collins, M.P. (1986). "The modified compression-field theory for reinforced-concrete elements subjected to shear", *Journal of the American Concrete Institute*, Vol. 83, No. 2, pp. 219-231.
- Walkup, S.L. (1998). Rehabilitation of non-ductile reinforced concrete building columns using fiber reinforced polymer jackets, MSc, Theses and Dissertations, Paper 548, Dept. of Civil and Environmental Engineering, Lehigh University, USA.
- Xiao, Y. and Ma, R. (1997). "Seismic retrofit of RC circular columns using prefabricated composite jacketing", *Journal of Structural Engineering-ASCE*, Vol. 123, No. 10, pp. 1357-1364.
- Yalçın, C. and Kaya, O. (2004). "An experimental study on the behaviour of reinforced concrete columns using FRP material", Proc. of the 13th World Conference on Earthquake Engineering, Vancouver, BC, Canada, paper no. 919 (in CD-ROM).
- Youm, K.S., Lee, Y.H., Choi, Y.M., Hwang, Y.K. and Kwon, T.G. (2007). "Seismic performance of lap-spliced columns with glass FRP", *Magazine of Concrete Research*, Vol. 59, No. 3, pp. 189-198.
- Zuo, J. and Darwin, D. (2000). "Splice strength of conventional and high relative rib area bars in normal and high-strength concrete", *ACI Structural Journal*, Vol. 97, No. 4, pp. 630-641.

**FIGURES**

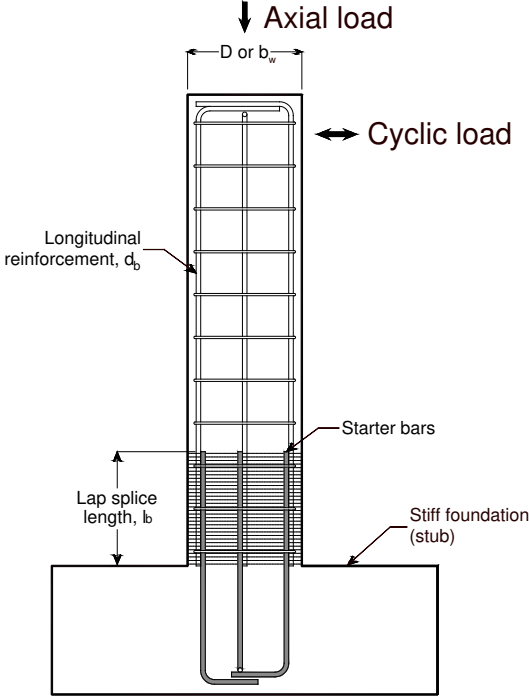

**Figure 1.** (a) FRP confinement around a lap-spliced cantilever column specimen.

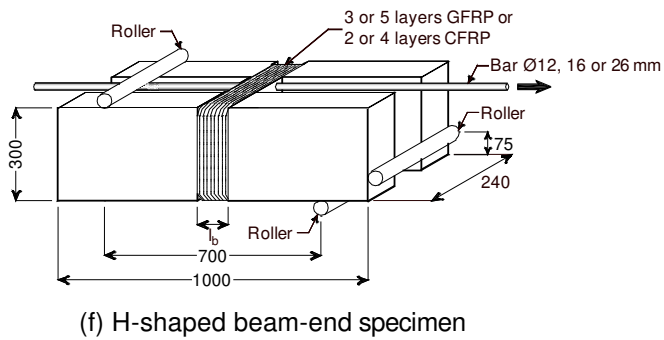
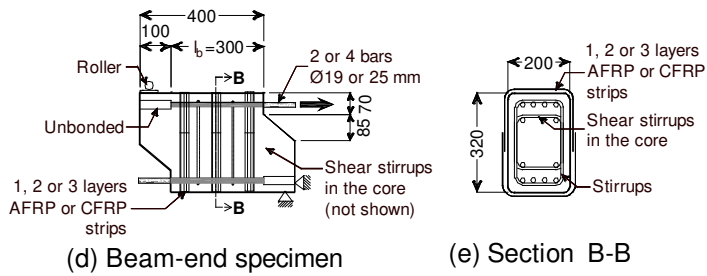
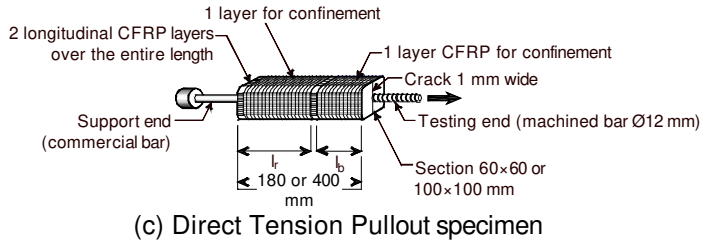
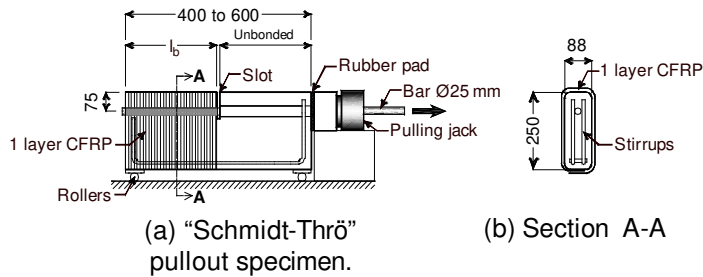

**Figure 2.** Specimens tested by (a)-(b) Kono et al. (1997); (c) Tastani and Pantazopoulou (2010); (d)-(e) Kono et al. (1999, 2000); and (f) Ozden and Akpınar (2007). Dimensions in mm.

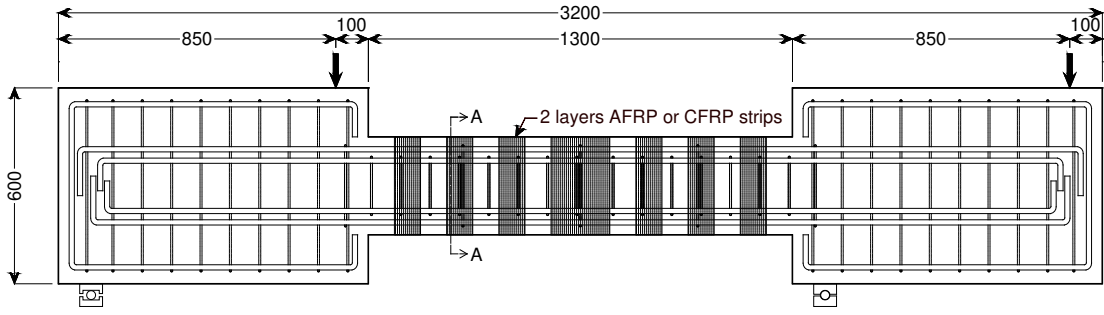

(a) Internal and external reinforcement

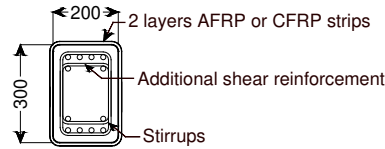

(b) Section A-A

Figure 3. Beams tested in double curvature by Kono et al. (1999). Dimensions in mm.

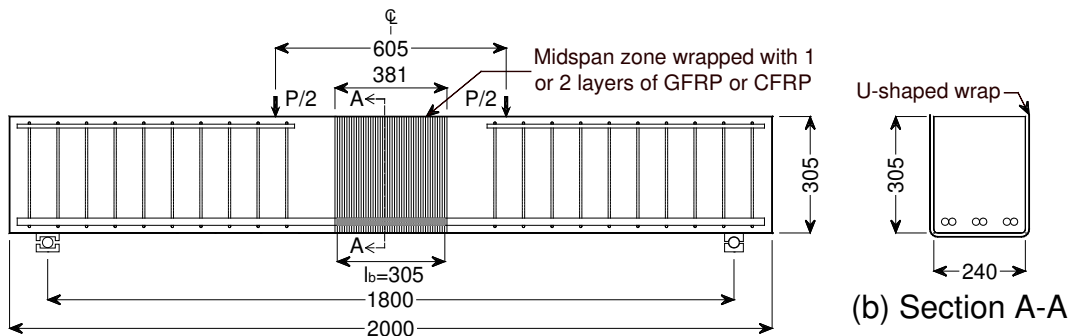

(a) Internal and external reinforcement

(case with continuous FRP wrap=381 mm)

(b) Section A-A

Figure 4. Beam splice specimens tested by Hamad and co-workers (2004a, 2004b, 2004c) and Hamad and Rteil (2006). Dimensions in mm.

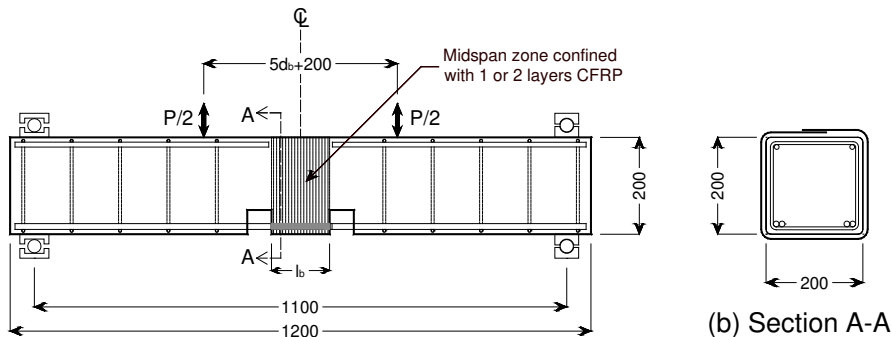

(a) Internal and external reinforcement

(b) Section A-A

Figure 5. Beam splice specimens tested by Harajli (2006). Dimensions in mm.

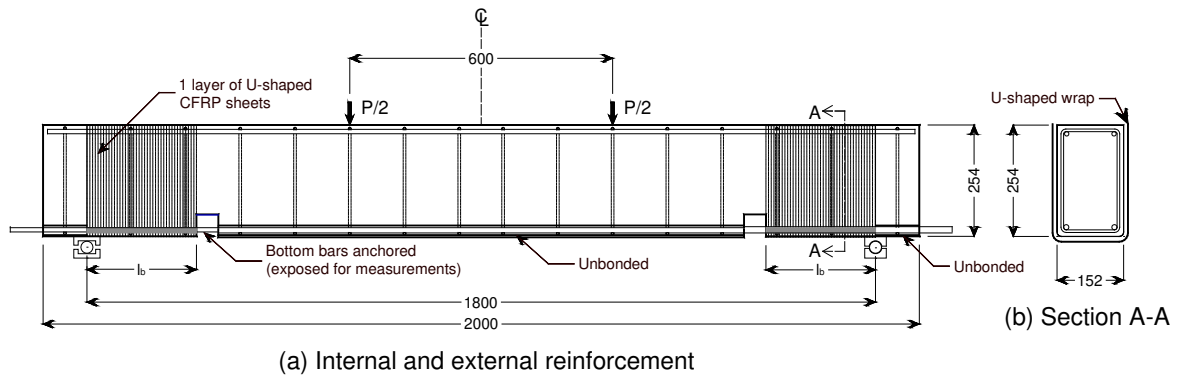

**Figure 6.** Beam anchorage specimens tested by Rteil et al. (2007). Dimensions in mm.

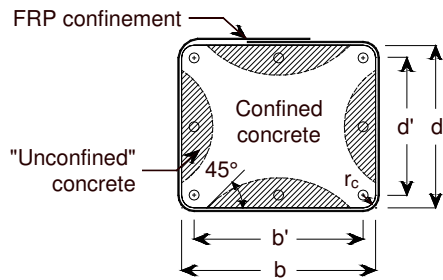

**Figure 7.** Cross section effectively confined in rectangular columns under pure axial compression (adapted from *fib* Bulletin 14 (2001)).

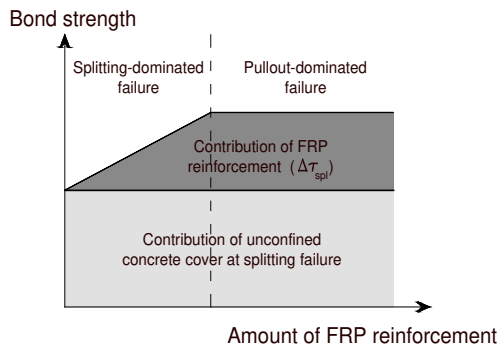

**Figure 8.** Bond strength enhancement provided by FRP reinforcement in an existing lap-spliced member.

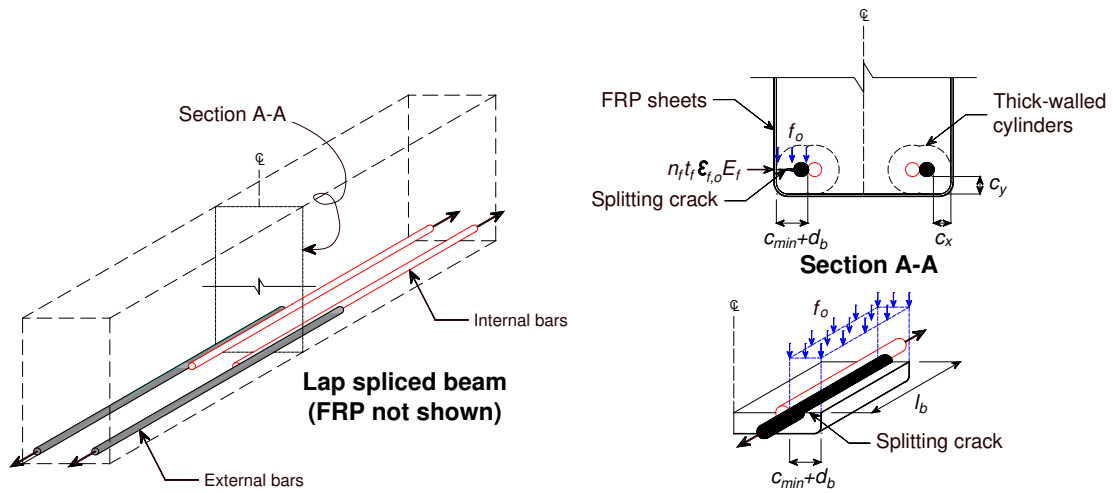

Figure 9. Bond-splitting failure assumptions in CFRP-confined splices assumed to develop model 12 (adapted from Garcia et al. 2014, Garcia et al. 2015)

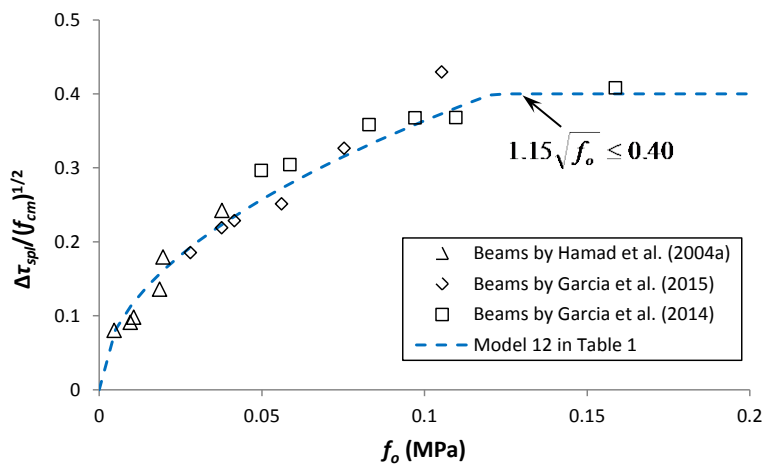

Figure 10. Comparison of proposed equation with experimental results, CFRP-confined beam splice specimens (adapted from Garcia et al. 2014, Garcia et al. 2015)

## TABLES

**Table 1.** Predictive models for FRP strengthening of RC members with substandard anchorages and lap splices (Units: MPa, mm and N)

ID	Author	Model	Comments	Additional nomenclature
<b>a) Design models</b>				
1	Priestley and co-workers <sup>(a)</sup> (Priestley et al. 1992, Priestley and Seible 1995, Seible et al. 1997), also Eurocode 8 Part 3 (2005), CNR-DT 200 (2012) & TEC (2007)	$n_f t_f = \frac{D(f_l - f_h)}{2\varepsilon_{fe} E_f}$ $f_l = \frac{A_{s1b} f_y}{\left(\frac{\pi D'}{2n_b} + 2(d_b + c)\right) l_b}$ $\varepsilon_{fe}=0.001$	Developed for lap splices of circular sections. Applicable to rectangular sections if cross section is modified to circular/oval.	$f_h$ =confining pressure from internal stirrups at a strain of 0.001 or prestressing stress $A_{s1b}$ =area of one lapped bar $D'$ = column diameter at the centreline of the lapped bars
2	Elnabelsy and Saatcioglu (2004)	$n_f t_f = \frac{2Df_c}{\varepsilon_{fe} E_f} \frac{P}{\phi P_0} \delta$ $\frac{P}{\phi P_0} \geq 0.20 \quad \varepsilon_{fe}=0.002$	Developed for lap splices of circular sections	$P_0$ and $P$ =nominal compressive strength and maximum axial compressive force on the column, respectively $\delta$ =lateral drift ratio $\phi$ = capacity reduction factor.
3	Elsanadedy and Haraoun (2005)	$n_f t_f = \frac{Df_l}{2\varepsilon_{fe} E_f}$ $f_l = \frac{1}{\mu} \left( \frac{f_y d_b}{4(l_b - 0.022 f_y d_b)} - \frac{20\sqrt{f_c}}{d_b} \right) \quad \varepsilon_{fe}=0.0015$	Developed for lap splices of circular sections	-

4	Hawkins and co-workers (Hawkins et al. 2000, Aquino and Hawkins 2007)	$n_f t_f = \frac{D f_{ci} l_b}{2 \varepsilon_{fe} E_f l_c}$ $v_{ci} = 0.18 v_{cim} + 1.64 f_{ci} - 0.82 \frac{f_{ci}^2}{v_{cim}} \quad f_{ci} \geq 0.24 \text{ MPa}$ $v_{ci} = \frac{A_{s1bs} f_u}{\left( \frac{\pi D''}{n} - d_{b1} - d_{b2} + c'' \right) l_b}$ $v_{cim} = \frac{\sqrt{f_c}}{0.31 + \frac{24w}{a+16}}$ $w = \frac{D'' \varepsilon_{fe}}{2} \leq 0.75 \text{ mm}$ $\varepsilon_{fe} = \min(\varepsilon_{fu}/3, 0.003)$	Developed for non-contact lap splices of circular sections	$f_{ci}$ = compressive stress necessary to develop $v_{ci}$ $l_c$ = length of FRP covering the splice $v_{ci}$ = shear stress on shearing plane $v_{cim}$ = maximum shear strength on shearing plane $A_{s1bs}$ = area of one starter bar $f_u$ = tensile strength of lapped bars $D''$ = column diameter at the centreline of the starter bars (non-contact splices) $d_{b1}$ = diameter of starter bar $d_{b2}$ = diameter of column bar $w$ = assumed crack width $a$ = maximum aggregate size $c''$ = cover to starter bars
5	Youm et al. (2007)	$n_f t_f = \frac{D(f_l - f_h)}{2 \varepsilon_{fe} E_f} \quad \varepsilon_{fe} = 0.002$	Same as model 1 but considering $\varepsilon_{fe} = 0.002$	-
<b>a) Bond strength enhancement models</b>				
6	Kono et al. (1999, 2000)	$\frac{\Delta \tau_{spl}}{\sqrt{f_c}} \approx \frac{1}{60} \left( \frac{E_f}{E_0} + 0.5 \right) \left( \frac{b_w}{d_b} \right) \left[ 1 - \left( \frac{\rho_f}{0.0035} - 1 \right)^2 \right]$ $\rho_f = \frac{2 n_f t_f b_f}{b_w s_f} \leq 0.35\% \quad E_0 = 230,000 \text{ MPa}$	Calibrated using results from beam-end specimens	$b_w$ = section width
7	Hamad and co-workers (2004a, 2004b, 2004c)	$\frac{\Delta \tau_{spl}}{\sqrt{f_c}} = \frac{A_f f_{fe}}{16.6 s_f n_b d_b} \leq 0.25$ $A_f = 2 n_f t_f b_f$	Calibrated using results from beam splice specimens. $f_{fe}$ computed according to ACI 440.2R (2008) for shear strengthening with FRP	-

8	Harajli et al. (2004) Harajli (2008)	$\frac{\Delta \tau_{spl}}{\sqrt{f_c}} = \frac{25r_e A_f}{s_f n_b d_b} \leq 0.40 \text{ (for strips)}$ $r_e = E_f / E_s$ $A_f = 2n_f t_f b_f$ $\frac{\Delta \tau_{spl}}{\sqrt{f_c}} = \frac{50r_e n_f \alpha_f t_f}{n_b d_b} \leq 0.40 \text{ (for continuous strips)}$ $n_f t_f = \frac{1000n_b d_b}{E_f (l_b / d_b)} \left[ \left( \frac{f_s}{\sqrt{f_c}} - 16.6 \right) - \frac{l_b}{d_b} \left( \frac{c}{d_b} + 0.4 \right) \right]$ $\frac{f_s}{\sqrt{f_c}} = \frac{l_b}{d_b} \left( \frac{E_f n_f t_f}{1000n_b d_b} + \frac{c}{d_b} + 0.4 \right) + 16.6$	Calibrated using results from beam splice specimens tested by Hamad and co-workers (2004a, 2004b, 2004c)	$f_s$ = Splice stress $\alpha_f$ = ratio of the width of the FRP sheets to the total splice length ( $\alpha_f=1$ for application of the FRP sheets along the full splice length).
9	Ozden and Akpınar (2007)	$\frac{\Delta \tau_{spl}}{\sqrt{f_c}} = 0.47 f_l \rightarrow \text{if } f_l \leq f_{l,lim}$ $\frac{\Delta \tau_{spl}}{\sqrt{f_c}} = 0.47 f_{l,lim} + \left( \frac{1+0.1\sqrt{f_c}}{100} \right) (f_l - f_{l,lim}) \rightarrow \text{if } f_l > f_{l,lim}$ $f_l = \frac{n_f t_f \varepsilon_{fe} E_f}{3d_b} \quad \varepsilon_{fe} = \varepsilon_{co} + 0.0004 \left( \frac{d_b^2 n_f t_f E_f}{4 \times 10^6} \right) \quad \varepsilon_{co} = 0.0012$ $f_{l,lim} = 1 + \left( 7.07 - \sqrt{f_c} \right) \frac{k_1}{d_b}$	Calibrated using results from beam-end specimens with $c=d_b$	$f_{l,lim}$ = confining stress defining the transition between splitting and pullout failures (dashed line in Figure 8) $k_1$ = aspect coefficient to consider the bar perimeter-area relationship (given in charts) $\varepsilon_{co}$ = concrete tensile strain at bond failure
10	Tastani and Pantazopoulou <sup>(b)</sup> (2008, 2010)	$\Delta \tau_{spl} = \frac{2\mu}{\pi d_b} \left( \frac{2n_f t_f \varepsilon_{fe} E_f}{n_b} \right)$ $\varepsilon_{fe} = \frac{u_r}{c + 0.5d_b} \quad u_r = 0.05 \text{ to } 0.10 \text{ mm}$	Based on a frictional approach	$u_r$ = radial displacement of concrete due to rib bearing action

11	Bournas and Triantafillou (2011)	$\Delta \tau_{spl} = \frac{d_b}{4l_b} \left[ 24.2 \left( \frac{l_b}{d_b} \right)^{0.55} (f_{ck})^{0.25} \left( \frac{c_{min}}{d_b} \right)^{0.33} \left( \frac{c_{max}}{c_{min}} \right)^{0.10} \left( \frac{20}{d_b} \right)^{0.20} \cdot K_f \right]$ $K_f = 2n_f t_f \left( k_s \frac{E_f \varepsilon_{fe}}{E_s \varepsilon_{st}} \right) \quad k_s = \frac{10}{d_b n_b}$ $\varepsilon_{fe} = 0.0049 - 9 \cdot 10^{-5} \left( \frac{l_b}{d_b} \right)$ $f_{ck} = f_{cm} - 8 \text{ MPa}$ $\varepsilon_{st} = 0.00134$	Based on Lettow and Eligehausen's (2006) bond equation	$f_{ck}$ = characteristic concrete compressive strength $f_{cm}$ = mean concrete compressive strength $c_{max}$ = maximum concrete cover $c_{min}$ = minimum concrete cover according to Model Code 2010 (2010) $K_f$ = confinement coefficient $k_s$ = calibration factor $\varepsilon_{st}$ = effective strain of the internal stirrups
12	Garcia et al. (2014, 2015)	$\Delta \tau_{spl} = 1.15 \sqrt{f_o} \leq 0.40$ $f_o = \frac{n_f t_f \varepsilon_{fe} E_f}{n_b (c_{min(x,y)} + d_b)}$ $\varepsilon_{fe} = \varepsilon_{ctm} = f_{ctm} / E_{cm}$	Based on a 'strain control' frictional approach and calibrated using beam splice results	$f_o$ = confining pressure due to FRP $c_{min(x,y)} = \min(c_x, c_y)$ , i.e. smallest of bottom or side free cover $\varepsilon_{ctm}$ = concrete tensile strain $E_{cm}$ = mean elastic modulus of concrete
13	AIJ guidelines (2002)	$\frac{\Delta \tau_{spl}}{\sqrt{f_c}} = 9.51 \frac{b_w \rho_f \kappa E_f}{n_b d_b E_s}$ $\kappa = 3 - 500 \frac{E_f}{E_s} \rho_f$ <p>if <math>\frac{E_f}{E_s} \rho_f \geq 0.003 \rightarrow \kappa = 1.5</math></p>	Based on Fujii and Morita (1983) model for steel confinement	-

14	Greek Code of Structural Interventions (EPPO 2012)	$\frac{A_f}{s} = \gamma_{Rd} \frac{(1-\lambda_s) 1}{\beta} \frac{f_{yk}}{\mu \sigma_f} \frac{A_{s1b}}{l_b}$ $A_f = t_f b_f$ $\frac{A_f}{s} = t_f \text{ (for continuous external jackets)}$ $t_f = \psi n_f t_{f1} \text{ (for multiple layers with thickness } t_{f1})$ $\sigma_f = E_f \varepsilon_{fe} \leq 0.75 E_f \varepsilon_{fu}$ $\varepsilon_{fe} = \sqrt{2} \frac{w}{b}$ $w = 0.6 s_d^{2/3} \quad \bar{b} \cong \frac{b_1 + b_2}{2}$ $\beta = \frac{b_{fc}}{B} \leq 1$	Based on a frictional approach. Model includes partial safety factors	$\gamma_{Rd}$ = partial safety factor = 1.5 $s$ = distance between confinement “collars” $\lambda_s$ = coefficient expressing the contribution of the already existing lap length to (recommended value $\lambda_s = 0$ ) $\psi$ = reduction factor due multiple layers = (no. of FRP layers) <sup>-1/4</sup> $\varepsilon_{fu}$ = ultimate tensile strain of FRP $s_d$ = acceptable relative slip (0.3 mm for performance level A; 0.4 mm for levels B and C) $b_1, b_2$ = two cross-sectional dimensions of splitting crack $b_{fc}$ = width of the friction zone on the crack along the spliced bars
		<sup>(a)</sup> $f_i$ includes an overstrength factor of 1.4 on the yield strength of steel <sup>(b)</sup> The original model includes the bond strength contributions from concrete cover, steel stirrups and normal pressure on the bars. The sum of these contributors and that from the FRP wraps is limited to a maximum of 0.3-0.4 $f_c$		

**Nomenclature:**

$A_f$ = area of FRP reinforcement

$b_f$ = width of one FRP strip

$c$ = clear concrete cover

$D$ = column diameter

$d_b$ = bar diameter

$E_f$ = elastic modulus of FRP

$f_c$ = concrete compressive strength

$f_l$ = lateral confining stress due to FRP

$f_y$ = yield strength of lapped bars

$l_b$ = lap splice length

$n_b$ = number of pairs of lapped bars

$n_f$ = number of FRP layers

$s_f$ = spacing between FRP strips

$t_f$ = thickness of one FRP layer

$\Delta\tau_{spl}$ = bond strength enhancement due to FRP confinement

$\epsilon_{fe}$ = effective FRP strain

$\mu=1.40$ = coefficient of friction

**Table 2 Test results and analytical predictions of bond strength and bond strength enhancement for beam specimens**

Beam	$f_{cm}$ (MPa)	$E_{cm}$ (GPa)	$f_{cim}$ (MPa)	$\varepsilon_{cim}$ ( $\mu\varepsilon$ )	$\tau_{spl,t}$ (MPa)	$\Delta\tau_{spl,t}$ (MPa)	$\frac{\Delta\tau_{spl,t}}{f_{cm}^{spl,t/2}}$	$n_f$	$t_f$ (mm)	$E_f$ (GPa)	$n_f t_f E_f$ (kN/mm)	$n_b$	$d_b$ (mm)	$l_b$ (mm)	$w_f$ (mm)	$s_f$ (mm)	$c_{min(x,y)}$ (mm)	$f_o$ (MPa)	$\frac{\Delta\tau_{spl,t}}{f_{cm}}$	T/P
Garcia et al. (2015)																				
SC10D12F1	37.6	32.7	2.81	86	5.59	1.40	0.23	1	0.117	240	28	2	12	120	120	120	17	0.04	0.23	0.97
SC10D12F2	22.5	28.1	2.63	94	6.23	2.04	0.43	2	0.117	240	56	2	12	120	120	120	13	0.11	0.37	1.15
SC20D12F1	37.6	32.7	2.81	86	5.97	1.34	0.22	1	0.117	240	28	2	12	120	120	120	20	0.04	0.22	0.98
SC20D12F2	37.6	32.7	2.81	86	6.62	2.00	0.33	2	0.117	240	56	2	12	120	120	120	20	0.08	0.32	1.03
SC27D16F1	37.6	32.7	2.81	86	5.34	1.14	0.19	1	0.117	240	28	2	16	160	160	160	27	0.03	0.19	0.96
SC27D16F2	37.6	32.7	2.81	86	5.75	1.54	0.25	2	0.117	240	56	2	16	160	160	160	27	0.06	0.27	0.92
Garcia et al. (2014)																				
LC10D12F1	27.9	29.9	2.45	82	5.20	1.89	0.36	1	0.185	241	45	2	12	300	300	300	10	0.08	0.33	1.08
LC10D12F2	27.9	29.9	2.45	82	5.47	2.16	0.41	2	0.185	241	89	2	12	300	300	300	11	0.16	0.40	1.02
LC20D12F1	24.7	28.9	2.20	76	4.86	1.51	0.30	1	0.185	241	45	2	12	300	300	300	17	0.06	0.28	1.09
LC20D12F2	24.7	28.9	2.20	76	5.18	1.83	0.37	2	0.185	241	89	2	12	300	300	300	19	0.11	0.38	0.97
LC27D16F1	25.7	29.2	2.48	85	4.80	1.50	0.30	1	0.185	241	45	2	16	400	400	400	22	0.05	0.26	1.15
LC27D16F2	25.7	29.2	2.48	85	5.16	1.86	0.37	2	0.185	241	89	2	16	400	400	400	23	0.10	0.36	1.03
Hamad et al. (2004c)																				
NC1S1	28.4	30.1	2.24	74	4.24	0.43	0.08	1	0.13	230	30	3	20	305	76	305	20	0.005	0.08	1.03
NC1S2	29.8	30.5	2.34	77	4.31	0.50	0.09	1	0.13	230	30	3	20	305	76	152	20	0.010	0.11	0.81
NC1S3	31.1	30.9	2.43	79	4.81	1.00	0.18	1	0.13	230	30	3	20	305	381	381	20	0.020	0.16	1.11
NC2S1	35.8	32.3	2.75	85	4.40	0.59	0.10	2	0.13	230	60	3	20	305	76	305	20	0.011	0.12	0.83
NC2S2	28.4	30.1	2.24	74	4.54	0.72	0.14	2	0.13	230	60	3	20	305	76	152	20	0.019	0.16	0.87
NC2S3	29.2	30.3	2.30	76	5.12	1.31	0.24	2	0.13	230	60	3	20	305	381	381	20	0.038	0.22	1.08
Harajli (2006)																				
B20FP1	35.6	32.2	2.74	85	8.35	3.28	0.55	1	0.13	230	30	2	20	100	100	100	30	0.03	0.18	3.00
B20FP2	35.6	32.2	2.74	85	7.46	2.39	0.40	2	0.13	230	60	2	20	100	100	100	30	0.05	0.26	1.54
B25FP1	28.8	30.2	2.27	75	5.10	1.23	0.23	1	0.13	230	30	2	25	125	125	125	25	0.02	0.17	1.33
B25FP2	28.8	30.2	2.27	75	6.06	2.20	0.41	2	0.13	230	60	2	25	125	125	125	25	0.04	0.24	1.68

B2W-CF1	41.9	33.8	3.14	93	8.29	1.55	0.24	1	0.13	230	30	2	20	100	100	100	30	0.03	0.19	1.25
B2W-CF2	40.6	33.5	3.06	91	7.65	1.02	0.16	2	0.13	230	60	2	20	100	100	100	30	0.05	0.27	0.60
B3W-CF1	37.4	32.7	2.86	87	5.44	1.10	0.18	1	0.13	230	30	2	25	125	125	125	25	0.03	0.19	0.97
B3W-CF2	41.5	33.7	3.12	92	5.86	1.29	0.2	2	0.13	230	60	2	25	125	125	125	25	0.06	0.27	0.74
Hamad et al. (2004a,2004b)																				
BC1S1	63.2	38.3	4.35	114	6.84	0.40	0.05	1	0.13	230	30	3	20	305	76	305	20	0.007	0.097	0.52
BC1S2	57.7	37.2	4.06	109	7.41	0.97	0.13	1	0.13	230	30	3	20	305	76	152	20	0.014	0.134	0.96
BC1S3	55.2	36.7	3.92	107	8.19	1.75	0.24	1	0.13	230	30	3	20	305	381	381	20	0.027	0.188	1.26
BG1S1	58.9	37.5	4.12	110	6.95	0.51	0.07	1	0.36	72.41	26	3	20	305	76	305	20	0.006	0.089	0.75
BG1S2	51.1	35.9	3.69	103	7.99	1.55	0.22	1	0.36	72.41	26	3	20	305	76	152	20	0.011	0.121	1.79
BG1S3	52.3	36.1	3.76	104	8.13	1.69	0.23	1	0.36	72.41	26	3	20	305	381	381	20	0.023	0.173	1.35
BG2S1	51.5	36.0	3.71	103	7.15	0.71	0.10	2	0.36	72.41	52	3	20	305	76	305	20	0.011	0.121	0.82
BG2S2	49.7	35.6	3.61	101	8.29	1.85	0.26	2	0.36	72.41	52	3	20	305	76	152	20	0.022	0.170	1.54
BG2S3	50.7	35.8	3.67	102	8.57	2.13	0.30	2	0.36	72.41	52	3	20	305	381	381	20	0.044	0.242	1.24
<b>Mean</b>																				<b>1.13</b>
<b>StdDev</b>																				<b>0.43</b>

**Table 3 Test results and analytical predictions of bond strength and bond strength enhancement for pullout specimens**

Specimen	$f_{cm}$ (MPa)	$E_{cm}$ (GPa)	$f_{ctm}$ (MPa)	$\varepsilon_{ctm}$ ( $\mu\varepsilon$ )	$\tau_{spl,t}$ (MPa)	$\Delta\tau_{spl,t}$ (MPa)	$\frac{\Delta\tau_{spl,t}}{f_{cm}^{1/2}}$	$n_f$	$t_f$ (mm)	$E_f$ (GPa)	$n_f t_f E_f$ (kN/mm)	$n_b$	$d_b$ (mm)	$l_b$ (mm)	$c_{min(x,y)}$ (mm)	$f_o$ (MPa)	$\frac{\Delta\tau_{spl,t}}{f_{cm}^{1/2}}$	T/P
Ozden and Akpinar (2007)																		
EC20D12FC2A	21.3	27.6	1.68	61	11.64	2.18	0.47	2	0.117	240	56	1	12	84	12	0.14	0.40	1.18
EC20D12FC2B	21.6	27.7	1.71	62	11.28	1.02	0.22	2	0.117	240	56	1	12	84	12	0.14	0.40	0.55
EC20D12FC4A	21.3	27.6	1.68	61	13.46	4.00	0.87	4	0.117	240	112	1	12	84	12	0.29	0.40	2.17
EC20D12FC4B	21.6	27.7	1.71	62	14.55	4.29	0.92	4	0.117	240	112	1	12	84	12	0.29	0.40	2.31
EC20D16FC2A	21.4	27.6	1.69	61	11.75	4.14	0.89	2	0.117	240	56	1	16	112	16	0.11	0.38	2.37
EC20D16FC2B	21.6	27.7	1.71	62	9.99	2.09	0.45	2	0.117	240	56	1	16	112	16	0.11	0.38	1.19
EC20D16FC2r	19.3	26.8	1.51	56	9.78	2.43	0.55	2	0.117	240	56	1	16	112	16	0.10	0.36	1.53
EC20D16FC4A	21.4	27.6	1.69	61	10.23	2.62	0.57	4	0.117	240	112	1	16	112	16	0.21	0.40	1.42
EC20D16FC4B	21.6	27.7	1.71	62	10.97	3.07	0.66	4	0.117	240	112	1	16	112	16	0.22	0.40	1.65
EC20D16FC4r	19.3	26.8	1.51	56	10.23	2.89	0.66	4	0.117	240	112	1	16	112	16	0.20	0.40	1.64
EC20D26FC2A	24.6	28.8	1.95	68	9.36	2.57	0.52	2	0.117	240	56	1	26	91	26	0.07	0.31	1.67
EC20D26FC2B	21.2	27.6	1.68	61	8.49	1.67	0.36	2	0.117	240	56	1	26	91	26	0.07	0.29	1.23
EC20D26FC4A	24.6	28.8	1.95	68	10.85	4.06	0.82	4	0.117	240	112	1	26	91	26	0.15	0.40	2.05
EC20D26FC4B	21.2	27.6	1.68	61	9.27	2.45	0.53	4	0.117	240	112	1	26	91	26	0.13	0.40	1.33
EC20D26FC4r	19.3	26.8	1.51	56	8.8	2.19	0.50	4	0.117	240	112	1	26	91	26	0.12	0.40	1.25
EC40D12FC2A	42.1	33.9	3.15	93	13.83	2.53	0.39	2	0.117	240	56	1	12	42	12	0.22	0.40	0.97
EC40D12FC2Ar	44.8	34.5	3.32	96	14.99	2.76	0.41	2	0.117	240	56	1	12	42	12	0.23	0.40	1.03
EC40D12FC2B	45.5	34.7	3.36	97	13.54	1.26	0.19	2	0.117	240	56	1	12	42	12	0.23	0.40	0.47
EC40D12FC2Br	41	33.6	3.09	92	15.14	3.93	0.61	2	0.117	240	56	1	12	42	12	0.21	0.40	1.53
EC40D12FC4A	42.1	33.9	3.15	93	14.41	3.10	0.48	4	0.117	240	112	1	12	42	12	0.44	0.40	1.20
EC40D12FC4Ar	44.8	34.5	3.32	96	15.43	3.20	0.48	4	0.117	240	112	1	12	42	12	0.45	0.40	1.20
EC40D12FC4B	45.5	34.7	3.36	97	17.17	4.87	0.72	4	0.117	240	112	1	12	42	12	0.45	0.40	1.81
EC40D12FC4Br	41	33.6	3.09	92	15.72	4.51	0.70	4	0.117	240	112	1	12	42	12	0.43	0.40	1.76

EC40D16FC2A	40.6	33.5	3.06	91	14.33	5.24	0.82	2	0.117	240	56	1	16	56	16	0.16	0.40	2.06
EC40D16FC2B	42.9	34.1	3.20	94	12.28	1.39	0.21	2	0.117	240	56	1	16	56	16	0.17	0.40	0.53
EC40D16FC4A	40.6	33.5	3.06	91	15.55	6.46	1.01	4	0.117	240	112	1	16	56	16	0.32	0.40	2.53
EC40D16FC4B	42.9	34.1	3.20	94	13.02	2.13	0.33	4	0.117	240	112	1	16	56	16	0.33	0.40	0.81
EC40D26FC2A	43.5	34.2	3.24	95	11.59	3.99	0.60	2	0.117	240	56	1	26	91	26	0.10	0.37	1.64
EC40D26FC2B	45.2	34.6	3.34	97	11.22	2.48	0.37	2	0.117	240	56	1	26	91	26	0.10	0.37	0.99
EC40D26FC4A	43.5	34.2	3.24	95	11.38	3.78	0.57	4	0.117	240	112	1	26	91	26	0.20	0.40	1.43
EC40D26FC4B	45.2	34.6	3.34	97	11.44	2.70	0.40	4	0.117	240	112	1	26	91	26	0.21	0.40	1.00
EC20D12FG3A	21.3	27.6	1.68	61	13.1	3.64	0.79	3	0.157	73	34	1	12	84	12	0.09	0.34	2.32
EC20D12FG3B	21.6	27.7	1.71	62	13.17	2.91	0.63	3	0.157	73	34	1	12	84	12	0.09	0.34	1.83
EC20D12FG5A	21.3	27.6	1.68	61	12.08	2.62	0.57	5	0.157	73	57	1	12	84	12	0.15	0.40	1.42
EC20D12FG5B	21.6	27.7	1.71	62	11.86	1.6	0.34	5	0.157	73	57	1	12	84	12	0.15	0.40	0.86
EC20D16FG3A	21.4	27.6	1.69	61	9.5	1.89	0.41	3	0.157	73	34	1	16	112	16	0.07	0.29	1.39
EC20D16FG3B	21.6	27.7	1.71	62	8.96	1.06	0.23	3	0.157	73	34	1	16	112	16	0.07	0.30	0.77
EC20D16FG5A	21.4	27.6	1.69	61	11.91	4.3	0.93	5	0.157	73	57	1	16	112	16	0.11	0.38	2.44
EC20D16FG5B	21.6	27.7	1.71	62	9.46	1.56	0.34	5	0.157	73	57	1	16	112	16	0.11	0.38	0.88
EC20D16FG5R	19.3	26.8	1.51	56	10.56	2.95	0.67	5	0.157	73	57	1	16	112	16	0.10	0.37	1.84
EC20D26FG3A	24.6	28.8	1.95	68	8.96	2.17	0.44	3	0.157	73	34	1	26	91	26	0.04	0.24	1.80
EC20D26FG3B	21.2	27.6	1.68	61	8.8	1.98	0.43	3	0.157	73	34	1	26	91	26	0.04	0.23	1.87
EC20D26FG5A	24.6	28.8	1.95	68	9.55	2.76	0.56	5	0.157	73	57	1	26	91	26	0.07	0.31	1.77
EC20D26FG5R	19.3	26.8	1.51	56	9.08	2.29	0.52	5	0.157	73	57	1	26	91	26	0.06	0.29	1.82
EC40D12FG3AR	44.8	34.5	3.32	96	15.14	2.91	0.43	3	0.157	73	34	1	12	42	12	0.14	0.40	1.09
EC40D12FG3BR	41	33.6	3.09	92	13.68	2.47	0.39	3	0.157	73	34	1	12	42	12	0.13	0.40	0.96
EC40D12FG5A	42.1	33.9	3.15	93	15.43	3.2	0.49	5	0.157	73	57	1	12	42	12	0.22	0.40	1.23
EC40D12FG5AR	44.8	34.5	3.32	96	13.24	1.01	0.15	5	0.157	73	57	1	12	42	12	0.23	0.40	0.38
EC40D12FG5B	45.5	34.7	3.36	97	15.28	4.07	0.60	5	0.157	73	57	1	12	42	12	0.23	0.40	1.51
EC40D12FG5BR	41	33.6	3.09	92	14.99	3.78	0.59	5	0.157	73	57	1	12	42	12	0.22	0.40	1.48
EC40D16FG3A	40.6	33.5	3.06	91	11.71	2.62	0.41	3	0.157	73	34	1	16	56	16	0.10	0.36	1.14
EC40D16FG3B	42.9	34.1	3.20	94	11.87	0.98	0.15	3	0.157	73	34	1	16	56	16	0.10	0.37	0.41

EC40D16FG5A	40.6	33.5	3.06	91	12.77	3.68	0.58	5	0.157	73	57	1	16	56	16	0.16	0.40	1.44
EC40D16FG5B	42.9	34.1	3.20	94	14.24	3.35	0.51	5	0.157	73	57	1	16	56	16	0.17	0.40	1.28
EC40D26FG3A	43.5	34.2	3.24	95	10.73	3.13	0.47	3	0.157	73	34	1	26	91	26	0.06	0.29	1.65
EC40D26FG3B	45.2	34.6	3.34	97	10.57	1.83	0.27	3	0.157	73	34	1	26	91	26	0.06	0.29	0.94
EC40D26FG5A	43.5	34.2	3.24	95	11.44	3.84	0.58	5	0.157	73	57	1	26	91	26	0.10	0.37	1.57
EC40D26FG5B	45.2	34.6	3.34	97	11.38	2.64	0.39	5	0.157	73	57	1	26	91	26	0.11	0.38	1.05
Kono et al. (1999, 2000)																		
C3-CFRP	29.4	30.4	2.31	76	6.43	1.35	0.25	2	0.167	230	77	2	19	300	40	0.05	0.26	0.97
C4-CFRP	29.4	30.4	2.31	76	7.11	1.09	0.20	2	0.167	230	77	2	19	300	57	0.04	0.23	0.89
C7-CFRP	29.4	30.4	2.31	76	3.9	1.36	0.25	2	0.167	230	77	4	19	300	40	0.02	0.18	1.39
C8-CFRP	29.4	30.4	2.31	76	4.31	1.31	0.24	2	0.167	230	77	4	19	300	57	0.02	0.16	1.52
C9-CFRP	29.4	30.4	2.31	76	3.39	0.85	0.16	3	0.167	230	115	4	19	300	40	0.04	0.22	0.71
C10-CFRP	29.4	30.4	2.31	76	3.78	0.78	0.14	3	0.167	230	115	4	19	300	57	0.03	0.20	0.74
C13-CFRP	24.5	28.8	1.94	68	6.71	1.04	0.21	2	0.167	230	77	2	19	300	72	0.03	0.19	1.08
C14-CFRP	24.5	28.8	1.94	68	5.33	1.02	0.21	2	0.167	230	77	2	25	300	57	0.03	0.20	1.01
C17-CFRP	24.5	28.8	1.94	68	5.28	2.17	0.44	2	0.167	230	77	2	25	300	40	0.04	0.23	1.91
C18-CFRP	24.5	28.8	1.94	68	4.9	0.88	0.18	2	0.167	230	77	2	25	300	40	0.04	0.23	0.77
C19-AFRP	24.5	28.8	1.94	68	5.38	0.30	0.06	2	0.286	118	67	2	19	300	40	0.04	0.23	0.27
C27-CFRP	27	29.6	2.14	72	5.22	0.44	0.08	1	0.167	230	38	2	19	300	40	0.02	0.18	0.48
C28-CFRP	27	29.6	2.14	72	3.03	0.45	0.09	1	0.167	230	38	4	19	300	40	0.01	0.12	0.70
C29-CFRP	27	29.6	2.14	72	5.32	0.81	0.16	1	0.167	230	38	2	19	300	40	0.02	0.18	0.88
C30-CFRP	27	29.6	2.14	72	3.24	0.57	0.11	1	0.167	230	38	4	19	300	40	0.01	0.12	0.88
C31-CFRP	27	29.6	2.14	72	5.42	0.64	0.12	2	0.167	230	77	2	19	300	40	0.05	0.25	0.49
C32-CFRP	27	29.6	2.14	72	3.22	0.64	0.12	2	0.167	230	77	4	19	300	40	0.02	0.18	0.70
C33-CFRP	27	29.6	2.14	72	5.42	0.64	0.12	3	0.167	230	115	2	19	300	40	0.07	0.31	0.40
C34-CFRP	27	29.6	2.14	72	3.75	1.17	0.23	3	0.167	230	115	4	19	300	40	0.04	0.22	1.04
C35-CFRP	27	29.6	2.14	72	6.2	1.42	0.27	4	0.167	230	154	2	19	300	40	0.09	0.35	0.78
C37-AFRP	27	29.6	2.14	72	5.52	0.74	0.14	1	0.286	118	34	2	19	300	40	0.02	0.17	0.86
C38-AFRP	27	29.6	2.14	72	2.89	0.31	0.06	1	0.286	118	34	4	19	300	40	0.01	0.12	0.51

C39-AFRP	27	29.6	2.14	72	5.05	0.27	0.05	2	0.286	118	67	2	19	300	40	0.04	0.23	0.22
C40-AFRP	27	29.6	2.14	72	3	0.42	0.08	4	0.286	118	135	4	19	300	40	0.04	0.23	0.35
Tastani and Pantazopoulou (2010)																		
h0.5-SpB-1	28.1	30.0	2.22	74	7.4	0.70	0.13	1	0.17	230	39	1	12	60	24	0.08	0.33	0.41
h0.5-SpB-2	28.1	30.0	2.22	74	6.1	0.75	0.14	1	0.17	230	39	1	12	60	24	0.08	0.33	0.43
h0.5-SpB-3	28.1	30.0	2.22	74	11.4	6.05	1.14	1	0.17	230	39	1	12	60	24	0.08	0.33	3.50
h1.1-SpB-1	28.1	30.0	2.22	74	15	8.30	1.57	1	0.17	230	39	1	12	60	24	0.08	0.33	4.80
h1.1-SpB-2	28.1	30.0	2.22	74	14	7.00	1.32	1	0.17	230	39	1	12	60	24	0.08	0.33	4.05
h0.5-LpB-2	28.1	30.0	2.22	74	10.7	3.90	0.74	1	0.17	230	39	1	12	144	44.4	0.05	0.26	2.83
h1.1-LpB-1	28.1	30.0	2.22	74	9.6	3.10	0.58	1	0.17	230	39	1	12	144	44.4	0.05	0.26	2.25
h1.1-LpB-2	28.1	30.0	2.22	74	12.3	3.70	0.70	1	0.17	230	39	1	12	144	44.4	0.05	0.26	2.68
h0.5-LpB-1	28.1	30.0	2.22	74	5.3	-1.20 <sup>a</sup>	-	1	0.17	230	39	1	12	144	44.4	-	-	-
h0.5-LpB-3	28.1	30.0	2.22	74	6	-0.50 <sup>a</sup>	-	1	0.17	230	39	1	12	144	44.4	-	-	-
<b>Mean</b>																		<b>1.36</b>
<b>StdDev</b>																		<b>0.80</b>
<sup>a</sup> Negative values and thus considered as outliers																		