



Deposited via The University of Leeds.

White Rose Research Online URL for this paper:

<https://eprints.whiterose.ac.uk/id/eprint/104922/>

Version: Accepted Version

Proceedings Paper:

Zonetti, D, Ortega, R and Schiffer, JF (2016) A tool for power flow analysis of a generalized class of droop controllers for high-voltage direct-current transmission systems. In: Decision and Control (CDC), 2016 IEEE 55th Annual Conference on. 55th IEEE Conference on Decision and Control, 12-14 Dec 2016, Las Vegas, United States. Institute of Electrical and Electronics Engineers (IEEE). ISBN: 978-1-5090-1837-6.

<https://doi.org/10.1109/CDC.2016.7798488>

© 2016, IEEE. Personal use of this material is permitted. Permission from IEEE must be obtained for all other users, including reprinting/ republishing this material for advertising or promotional purposes, creating new collective works for resale or redistribution to servers or lists, or reuse of any copyrighted components of this work in other works.

Reuse

Items deposited in White Rose Research Online are protected by copyright, with all rights reserved unless indicated otherwise. They may be downloaded and/or printed for private study, or other acts as permitted by national copyright laws. The publisher or other rights holders may allow further reproduction and re-use of the full text version. This is indicated by the licence information on the White Rose Research Online record for the item.

Takedown

If you consider content in White Rose Research Online to be in breach of UK law, please notify us by emailing eprints@whiterose.ac.uk including the URL of the record and the reason for the withdrawal request.

A tool for power flow analysis of a generalized class of droop controllers for high-voltage direct-current transmission systems

Daniele Zonetti, Romeo Ortega and Johannes Schiffer

Abstract—The problem of primary control of high-voltage direct current transmission systems is addressed in this paper, which contains three main contributions. First, to propose a new nonlinear, more realistic, model for the system suitable for primary control design, which takes into account nonlinearities introduced by conventional inner controllers. Second, to determine necessary conditions—dependent on some free controller tuning parameters—for the existence of equilibria. Third, to formulate additional (necessary) conditions for these equilibria to satisfy the power sharing constraints. The usefulness of the theoretical results is illustrated via numerical calculations on a four-terminal example.

I. INTRODUCTION

For its correct operation, high-voltage direct current (hvdc) transmission systems—like all electrical power systems—must satisfy a large set of different regulation objectives that are, typically, associated to the multiple time-scale behavior of the system. One way to deal with this issue, that prevails in practice, is the use of hierarchical control architectures [1]–[3]. Usually, at the top of this hierarchy, a centralized controller called *tertiary control*—based on power flow optimization algorithms (OPFs)—is in charge of providing the inner controllers with the operating point to which the system has to be driven, according to technical and economical constraints [1]. If the tertiary control had exact knowledge of such constraints and of the desired operating points of all terminals, then it would be able to formulate a nominal optimization problem and the lower level controllers could operate under *nominal conditions*. However, such exact knowledge of all system parameters is impossible in practice, due to uncertainties and lack of information. Hence, the operating points generated by the tertiary controller may, in general, induce unsuitable *perturbed conditions*. To cope with this problem further control layers, termed *primary* and *secondary control*, are introduced. These take action—whenever a perturbation occurs—by promptly adjusting the references provided by the tertiary control in order to preserve properties that are essential for the correct and safe operation of the system. This paper focuses on the primary control layer. Irrespectively of the perturbation and in addition to ensuring stability, the primary control has the task of preserving two fundamental criteria: a prespecified power distribution

(*power sharing*) and keeping the terminal voltages near the nominal value [4]. Both objectives are usually achieved by an appropriate control of the dc voltage of one or more terminals at their point of interconnection with the hvdc network [2], [5], [6].

Clearly, a *sine qua non* requirement for the fulfillment of these objectives is the existence of a *stable equilibrium point* for the perturbed system. The ever increasing use of power electronic devices in modern electrical networks, in particular the presence of *constant power devices* (CPDs), induces a highly nonlinear behavior in the system—rendering the analysis of existence and stability of equilibria very complicated. Since linear, inherently stable, models, are usually employed for the description of primary control of dc grids [3], [6], [7], little attention has been paid to the issues of stability and existence of equilibria. This fundamental aspect of the problem has only recently attracted the attention of power systems researchers [8]–[10] who, similarly to the present work, invoke tools of nonlinear dynamic systems analysis, to deal with the intricacies of the actual nonlinear behavior.

The main contributions and the organization of the paper are as follows. Section II is dedicated to the formulation—under some reasonable assumptions—of a reduced, nonlinear model of the hvdc transmission system in closed-loop with standard inner-loop controllers. A first implication is that the obtained *nonlinear* model may in general have no equilibria. Then, we consider a generalized class of primary controllers, that includes the special case of the ubiquitous *voltage droop control*, and establish necessary conditions on the control parameters for the existence of an equilibrium point. This is done in Section III. An extension of this result to the problem of existence of equilibria that verify the power sharing property is carried out in Section IV. Due to space limitations, all proofs are omitted, for which the reader is referred to [11]. The usefulness of the theoretical results is illustrated with a numerical example in Section V. We wrap-up the paper by drawing some conclusions and providing guidelines for future investigation.

Notation. For a set $\mathcal{N} = \{l, k, \dots, n\}$ of, possibly unordered, elements, we denote with $i \sim \mathcal{N}$ the elements $i = l, k, \dots, n$. All vectors are column vectors. Given positive integers n, m , the symbol $0_n \in \mathbb{R}^n$ denotes the vector of all zeros, $0_{n \times m}$ the $n \times m$ column matrix of all zeros, $1_n \in \mathbb{R}^n$ the vector with all ones and \mathbb{I}_n the $n \times n$ identity matrix. When clear from the context dimensions are omitted and

D. Zonetti and R. Ortega are with the Laboratoire des Signaux et Systèmes, 3, rue Joliot Curie, 91192 Gif-sur-Yvette, France. daniele.zonetti(romeo.ortega)@lss.supelec.fr

J. Schiffer is with the School of Electronic and Electrical Engineering, University of Leeds, Leeds LS2 9JT, UK, j.schiffer@leeds.ac.uk

vectors and matrices are simply denoted by the symbols 0 , 1 or \mathbb{I} . For a given matrix A , the i -th column is denoted by A_i . $\text{diag}\{a_i\}$ is a diagonal matrix with entries $a_i \in \mathbb{R}$ and $\text{bdiag}\{A_i\}$ denotes a block diagonal matrix with matrix-entries A_i . Also, $x := \text{col}(x_1, \dots, x_n) \in \mathbb{R}^n$ denotes a vector with entries $x_i \in \mathbb{R}$. When clear from the context it is simply referred to as $x := \text{col}(x_i)$.

II. NONLINEAR MODELING OF HVDC SYSTEMS

A. A graph description

The main components of an hvdc transmission system are ac to dc power converters and dc transmission lines. The power converters connect ac subsystems—that are associated to renewable generating units or to ac grids—to an hvdc network. In [12] it has been shown that an hvdc transmission system can be represented by a directed graph¹ without self-loops, where the power units—*i.e.* power converters and transmission lines—correspond to edges and the buses correspond to nodes. A first step towards the construction of a suitable model for primary control analysis and design is the definition of an appropriate graph description of the system topology that takes into account the primary control action.

We consider an hvdc transmission system described by a graph $\mathcal{G}^\dagger(\mathcal{N}, \mathcal{E})$, where $n = c + 1$ is the number of nodes and $m = c + t$ is the number of edges, with c and t the number of converter and transmission units respectively. We further denote by p the number of converter units not equipped with primary control—termed *PQ units* hereafter—and by v the number of converter units equipped with primary control—that we call *voltage-controlled units*. To facilitate reference to different units we find it convenient to partition the set of nodes (respectively converter edges) into two ordered subsets \mathcal{N}_P and \mathcal{N}_V (respectively \mathcal{E}_P and \mathcal{E}_V) corresponding to PQ and voltage-controlled nodes (respectively edges). The incidence matrix associated to the graph is given by:

$$\mathcal{B} = \begin{bmatrix} \mathbb{I}_p & 0 & \mathcal{B}_P \\ 0 & \mathbb{I}_v & \mathcal{B}_V \\ -1_p^\top & -1_v^\top & 0 \end{bmatrix} \in \mathbb{R}^{n \times m}, \quad (\text{II.1})$$

where the submatrices \mathcal{B}_P and \mathcal{B}_V fully capture the topology of the hvdc network with respect to the different units.

B. Converter units

For the description of the converter units we consider power converters based on voltage source converter (VSC) technology [13]. The following assumption is made.

Assumption 2.1: All VSCs are controlled via stable direct current control schemes. Moreover, such schemes guarantee instantaneous and exact tracking of the desired currents.

This assumption can be justified by an appropriate design of the current inner-loop control scheme so that the resulting closed-loop system is internally stable and has a very large bandwidth compared to the voltage dynamics and to the outer

loops. Under Assumption 2.1, the reduced-order model of the VSC at the i -th node employed in this work is given by the following scalar system:

$$C_i \dot{v}_{C,i} = -G_i v_{C,i} + i_i^* + i_{C,i}, \quad i_i^* := i_{d,i}^* + i_{q,i}^*, \quad (\text{II.2})$$

where v_C denotes the dc voltage, $i_{d,i}^*, i_{q,i}^*$ denote the current references for the underlying current controller (the dynamics of which are neglected under Assumption 2.1), $i_{C,i}$ denotes the network current, $C_i \in \mathbb{R}_+$ and $G_i \in \mathbb{R}_+$ denote the capacitance and conductance respectively.

By using (II.2) as a point of departure, we derive the closed-loop dynamics of the *PQ* and *voltage-controlled units*. Recall that the current references are obtained by an outer power loop, which is based on the following definitions of instantaneous active and reactive power [14]:

$$P_i := V_{d,i} i_{d,i} + V_{q,i} i_{q,i}, \quad Q_i := V_{d,i} i_{q,i} - V_{q,i} i_{d,i}, \quad (\text{II.3})$$

where $V_{d,i}, V_{q,i}$ and $i_{d,i}, i_{q,i}$ are respectively the dq -transformed ac voltages and currents of the converter. For simplicity, we further assume that the current inner-loop employs a time-varying dq transformation such that $V_{q,i}$ is always kept to zero.

An important observation that follows from Assumption 2.1 is that the ac voltage dynamics evolve at a much slower time-scale than the time-scale at which the power converter is operated. For this reason $V_{d,i}$ is seen as constant from the point of view of the converter and the regulation of active and reactive power is—up to a scaling factor—equivalent to the regulation of the direct and quadrature currents [12]. Nevertheless, at the time-scale at which the outer-loop dynamics evolve, $V_{d,i}$ is not constant, so that the current references $i_{d,i}^*, i_{q,i}^*$ —which are established using (II.3) for some fixed powers P_i^*, Q_i^* —vary as well, implying for the system instantaneous tracking of powers rather than currents. Hence, the controlled ac-side can be approximated by the parallel connection of two power sources, so that the injected power at the i -th converter unit is given by:

$$S_i^* := V_{d,i} i_{d,i}^* + V_{d,i} i_{q,i}^* = V_{d,i} i_i^*, \quad i \sim \mathcal{E}_P \cup \mathcal{E}_V. \quad (\text{II.4})$$

If the unit is a *PQ unit* then, the current references are simply determined by the outer power loop via (II.3), which by noting that $V_{q,j} = 0$, gives

$$i_{d,j}^* = \frac{P_j^*}{V_{d,j}}, \quad i_{q,j}^* = \frac{Q_j^*}{V_{d,j}}, \quad j \sim \mathcal{E}_P. \quad (\text{II.5})$$

Hence, by replacing these expressions into (II.4) we obtain the injected power for the *PQ units*:

$$S_j^* = P_j^* + Q_j^*, \quad j \sim \mathcal{E}_P, \quad (\text{II.6})$$

which corresponds to a constant power device of value $P_{P,j}^* := P_j^* + Q_j^*$, see Fig. 1a. On the other hand, if the converter unit is a *voltage-controlled unit*, the current references are defined according to the primary control strategy. A common approach in this scenario is to introduce an additional deviation (also called *droop*) in the direct current reference—obtained from the outer power loop—as

¹A directed graph is an ordered 3-tuple, $\mathcal{G}^\dagger = \{\mathcal{N}, \mathcal{E}, \Pi\}$, consisting of a finite set of nodes \mathcal{N} , a finite set of directed edges \mathcal{E} and a mapping Π from \mathcal{E} to the set of ordered pairs of \mathcal{N} .

a function of the dc voltage, while keeping the reference of the quadrature current unchanged:

$$i_{d,k}^* = \frac{P_k^*}{V_{d,k}} + \delta_k(v_{C,k}), \quad i_{q,k}^* = \frac{Q_k^*}{V_{d,k}}, \quad k \sim \mathcal{E}_V, \quad (\text{II.7})$$

where $\delta_k(v_{C,k})$ represents the state-dependent contribution provided by the primary control. We propose to take:

$$\delta_k(v_{C,k}) = \frac{1}{V_{d,k}}(\mu_{P,k} + \mu_{I,k}v_{C,k} - \mu_{Z,k}v_{C,k}^2), \quad k \sim \mathcal{E}_V, \quad (\text{II.8})$$

where $\mu_{P,k}, \mu_{I,k} \in \mathbb{R}, \mu_{Z,k} \in \mathbb{R}_+$ are free control parameters. By replacing (II.7)-(II.8) into (II.4), we obtain the injected power for the *voltage-controlled units*:

$$S_k^*(v_{C,k}) = P_{V,k}^* + \mu_{I,k}v_{C,k} - \mu_{Z,k}v_{C,k}^2, \quad k \sim \mathcal{E}_V, \quad (\text{II.9})$$

with $P_{V,k}^* := P_k^* + Q_k^* + \mu_{P,k}$, which corresponds to a ZIP model, *i.e.* the parallel connection of a constant impedance $\mu_{Z,k}$ (Z), a constant current source/sink $\mu_{I,k}$ (I) and a constant power device $P_{V,k}^*$ (P)—see also Fig. 1b. Based on these approximations and recalling (II.2), the dynamics of the *PQ units* can be represented by the following scalar systems:

$$\begin{aligned} C_j \dot{v}_{C,j} &= -G_j v_{C,j} + u_j + i_{C,j}, \\ 0 &= P_{P,j}^* - v_{C,j} u_j, \end{aligned} \quad (\text{II.10})$$

while for the dynamics of the *voltage-controlled units* we have:

$$\begin{aligned} C_k \dot{v}_{C,k} &= -(G_k + \mu_{Z,k})v_{C,k} + \mu_{I,k} + u_k + i_{C,k}, \\ 0 &= P_{V,k}^* - v_{C,k} u_k, \end{aligned} \quad (\text{II.11})$$

where $j \sim \mathcal{E}_P, k \sim \mathcal{E}_V, v_{C,j}, v_{C,k} \in \mathbb{R}_+$ denote the voltages across the capacitors, $i_{C,j}, i_{C,k} \in \mathbb{R}$ denote the network currents, $u_j, u_k \in \mathbb{R}$ denote the currents flowing into the constant power devices and $G_j, G_k, C_j, C_k \in \mathbb{R}_+$ denote the conductances and capacitances. The aggregated model is then given by:

$$\begin{aligned} \begin{bmatrix} C_P \dot{v}_P \\ C_V \dot{v}_V \end{bmatrix} &= - \begin{bmatrix} G_P & 0 \\ 0 & G_V + G_Z \end{bmatrix} \begin{bmatrix} v_P \\ v_V \end{bmatrix} + \\ &+ \begin{bmatrix} u_P \\ u_V \end{bmatrix} + \begin{bmatrix} 0 \\ \bar{u}_V \end{bmatrix} + \begin{bmatrix} i_P \\ i_V \end{bmatrix}, \end{aligned} \quad (\text{II.12})$$

together with the algebraic constraints:

$$P_{P,j}^* = v_{P,j} u_{P,j}, \quad P_{V,k}^* = v_{V,k} u_{V,k}, \quad (\text{II.13})$$

$i \sim \mathcal{E}_P, k \sim \mathcal{E}_V$, with: state vectors $v_P := \text{col}(v_{C,j}) \in \mathbb{R}^p, v_V := \text{col}(v_{C,k}) \in \mathbb{R}^v$; external sources $\bar{u}_V := \text{col}(\mu_{I,k}) \in \mathbb{R}^v$; network currents $i_P := \text{col}(i_{C,j}) \in \mathbb{R}^p, i_V := \text{col}(i_{C,k}) \in \mathbb{R}^v$; currents flowing into the constant power devices $u_P := \text{col}(u_j) \in \mathbb{R}^p, u_V := \text{col}(u_k) \in \mathbb{R}^v$; matrices $C_P := \text{diag}\{C_j\} \in \mathbb{R}^{p \times p}, G_P := \text{diag}\{G_j\} \in \mathbb{R}^{p \times p}, C_V := \text{diag}\{C_k\} \in \mathbb{R}^{v \times v}, G_V := \text{diag}\{G_k\} \in \mathbb{R}^{v \times v}, G_Z := \text{diag}\{\mu_{Z,k}\} \in \mathbb{R}^{v \times v}$.

C. Hvdc network

For the model of the hvdc network we assume that the dc transmission lines can be described by single-cell *RL* circuits, for which it is straightforward to obtain the

aggregated model [12]:

$$L_T \dot{i}_T = -R_T i_T + v_T, \quad (\text{II.14})$$

with $i_T := \text{col}(i_{T,i}), v_T := \text{col}(v_{T,i}) \in \mathbb{R}^t$ denoting the currents through and the voltages across the lines and $L_T := \text{col}(L_{T,i}), R_T := \text{col}(R_{T,i}) \in \mathbb{R}^{t \times t}$ denoting the inductance and resistance matrices. We make the following assumption.

Assumption 2.2: The dynamics of the dc lines evolve on a time-scale that is much faster than the time-scale at which the dynamics of the voltage capacitors evolve.

This assumption is a generalization of a fairly standard assumption in traditional power systems, where this time-scale separation typically holds because of the very slow dynamics of generation and loads compared to those of transmission lines [15], [16]. Under Assumption 2.2, (II.14) reduces to:

$$i_T^* = G_T v_T, \quad (\text{II.15})$$

where i_T^* is the steady-state vector of the line currents and $G_T := R_T^{-1}$ the conductance matrix of the transmission lines.

D. Interconnected model

In order to obtain the reduced, interconnected model of the hvdc transmission system under Assumptions 2.1 and 2.2, we consider the interconnection laws determined by the incidence matrix (II.1). Let us define the node and edge vectors:

$$V_n := \begin{bmatrix} \mathcal{V}_P \\ \mathcal{V}_V \\ 0 \end{bmatrix} \in \mathbb{R}^{c+1}, \quad V_e := \begin{bmatrix} v_P \\ v_V \\ v_T \end{bmatrix} \in \mathbb{R}^m, \quad I_e := \begin{bmatrix} i_P \\ i_V \\ i_T \end{bmatrix} \in \mathbb{R}^m.$$

By using the definition of the incidence matrix (II.1) together with the Kirchhoff's current and voltage laws [17], [18]:

$$B I_e = 0, \quad V_e = \mathcal{B}^\top V_n, \quad (\text{II.16})$$

we obtain:

$$\begin{aligned} i_P &= -\mathcal{B}_P G_T \mathcal{B}_P^\top v_P - \mathcal{B}_P G_T \mathcal{B}_V^\top v_V, \\ i_V &= -\mathcal{B}_V G_T \mathcal{B}_P^\top v_P - \mathcal{B}_V G_T \mathcal{B}_V^\top v_V. \end{aligned} \quad (\text{II.17})$$

Replacing i_P and i_V in (II.12) by the expression (II.17), leads to the interconnected model:

$$\begin{aligned} \begin{bmatrix} C_P \dot{v}_P \\ C_V \dot{v}_V \end{bmatrix} &= - \begin{bmatrix} \mathcal{L}_P + G_P & \mathcal{L}_m \\ \mathcal{L}_m^\top & \mathcal{L}_V + G_V + G_Z \end{bmatrix} \begin{bmatrix} v_P \\ v_V \end{bmatrix} + \\ &+ \begin{bmatrix} u_P \\ u_V \end{bmatrix} + \begin{bmatrix} 0 \\ \bar{u}_V \end{bmatrix}, \end{aligned} \quad (\text{II.18})$$

together with the algebraic constraints:

$$P_{P,j}^* = v_{P,j} u_{P,j}, \quad P_{V,k}^* = v_{V,k} u_{V,k}, \quad (\text{II.19})$$

$i \sim \mathcal{E}_P, k \sim \mathcal{E}_V$ and where we defined

$$\mathcal{L}_P := \mathcal{B}_P G_L \mathcal{B}_P^\top, \quad \mathcal{L}_m := \mathcal{B}_P G_L \mathcal{B}_V^\top, \quad \mathcal{L}_V := \mathcal{B}_V G_L \mathcal{B}_V^\top.$$

Remark 2.3: With the following choice:

$$\mu_{P,k} = d_k V_{d,k} v_C^{\text{nom}}, \quad \mu_{I,k} = -d_k V_{d,k}, \quad \mu_{Z,k} = 0,$$

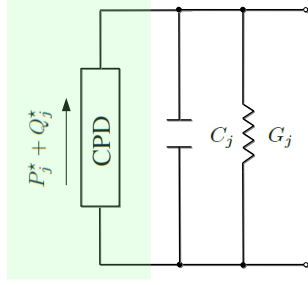

(a) Equivalent circuit scheme for PQ units.

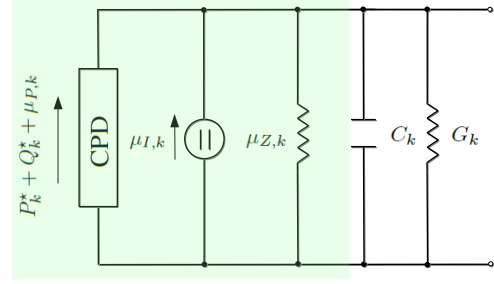

(b) Equivalent circuit scheme for *voltage-controlled* units.

Fig. 1: Equivalent circuit schemes of the converter units with constant power devices (CPDs), under Assumption 2.1.

where $k \sim \mathcal{E}_V$, the primary control (II.8) reduces to:

$$\delta_k(v_{C,k}) = -d_k(v_{C,k} - v_C^{\text{nom}}).$$

This is exactly the conventional voltage droop control [2], [6], [19], where d_k is called droop coefficient and v_C^{nom} is the nominal voltage of the hvdc system. Note that it can be interpreted as the parallel connection of a current sink with a constant power load, as in [4]. This should be contrasted with the models provided in [3], [7], where it is modeled as a current source in parallel connection with an impedance.

Remark 2.4: The model (II.18) can be also employed for the modeling of dc grids with no loss of generality. In fact, loads can be represented either by PQ units (constant power loads) or by *voltage-controlled units* with assigned parameters (ZIP loads). This model should be contrasted with the linear models adopted in [3], [7] where loads are modeled as constant current sinks.

Remark 2.5: The matrix:

$$\mathcal{L} := \begin{bmatrix} \mathcal{L}_P & \mathcal{L}_m \\ \mathcal{L}_m^\top & \mathcal{L}_V \end{bmatrix} \in \mathbb{R}^{c \times c}$$

is the Laplacian matrix associated to the weighted undirected graph $\bar{\mathcal{G}}^w$, obtained from the (unweighted directed) graph \mathcal{G}^\uparrow that describes the hvdc transmission system by: 1) eliminating the reference node and all edges connected to it; 2) assigning as weights of the edges corresponding to transmission lines the values of their conductances. Similar definitions are also encountered in [3], [7].

III. CONDITIONS FOR EXISTENCE OF AN EQUILIBRIUM POINT

From an electrical point of view, the reduced system (II.18) is a linear capacitive-resistive circuit, where at each node a constant power device is attached. It has been observed in experiments and simulations that the presence of constant power devices may seriously affect the dynamics of linear RLC circuits hindering the achievement of a constant, stable behavior of the state variables—the dc voltages in the present case [10], [20]–[22]. A first objective is thus to determine conditions on the free control parameters of

the system (II.18)-(II.19) that guarantee the existence of an equilibrium point. To simplify the notation, let us define

$$\begin{aligned} P_P^* &:= \text{col}(P_{P,j}^*) \in \mathbb{R}^p, & R_P &:= \mathcal{L}_P + G_P \in \mathbb{R}^{p \times p}, \\ P_V^* &:= \text{col}(P_{V,k}^*) \in \mathbb{R}^v, & R_V &:= \mathcal{L}_V + G_V + G_Z \in \mathbb{R}^{v \times v}. \end{aligned} \quad (\text{III.1})$$

In order to present the main result on existence of equilibria for the system (II.18), we further recall the following lemma, the proof of which can be found in [10].

Lemma 3.1: Consider m quadratic equations of the form $f_i : \mathbb{R}^n \rightarrow \mathbb{R}$,

$$f_i(x) := \frac{1}{2} x^\top \mathcal{A}_i x + x^\top \mathcal{B}_i, \quad i \in [1, m], \quad (\text{III.2})$$

where $\mathcal{A}_i = \mathcal{A}_i^\top \in \mathbb{R}^{n \times n}$, $\mathcal{B}_i \in \mathbb{R}^n$ and define:

$$\mathcal{A}(T) := \sum_{i=1}^m t_i \mathcal{A}_i, \quad \mathcal{B}(T) := \sum_{i=1}^m t_i \mathcal{B}_i, \quad \mathcal{C}(T) := \sum_{i=1}^m t_i c_i.$$

If the following LMI

$$\Upsilon(T) := \begin{bmatrix} \mathcal{A}(T) & \mathcal{B}(T) \\ \mathcal{B}^\top(T) & -2\mathcal{C}(T) \end{bmatrix} > 0,$$

is feasible, then the equations $f_i(x) = c_i$, with $i \in [1, m]$, have no solution.

We are now ready to formulate the following proposition, that establishes necessary, control parameter-dependent, conditions for the existence of equilibria of the system (II.18).

Proposition 3.2: Consider the system (II.18)-(II.19), for some given P_P^* , P_V^* . Suppose that there exist two diagonal matrices $T_P \in \mathbb{R}^{p \times p}$ and $T_V \in \mathbb{R}^{v \times v}$ such that:

$$\Upsilon(T_P, T_V) > 0, \quad (\text{III.3})$$

with

$$\Upsilon := \begin{bmatrix} T_P R_P + R_P T_P & T_P \mathcal{L}_m + \mathcal{L}_m^\top T_V & 0 \\ * & T_V R_V + R_V T_V & -T_V \bar{u}_V \\ * & * & -2(1_p^\top T_P P_P^* + 1_v^\top T_V P_V^*) \end{bmatrix},$$

where P_P^* , P_V^* , R_P and R_V are defined in (III.1). Then the system (II.18)-(II.19) does not admit an equilibrium point.

Remark 3.3: The feasibility of the LMI (III.3) depends on the control parameters G_Z , \bar{u}_V and P_V^* . Since the feasibility

condition is only necessary for the existence of equilibria for (II.18), it is of interest to determine regions for these parameters that imply non-existence of an equilibrium point.

IV. CONDITIONS FOR POWER SHARING

Another control objective of primary control is the achievement of *power sharing* among the voltage-controlled units. We introduce the following definition.

Definition 4.1: Let be $v^* := (v_P^*, v_V^*) \in \mathbb{R}^c$ an equilibrium point for (II.18)-(II.19), $\hat{P}_V(v^*) := \text{col}(\hat{P}_k(v_C^*, k)) \in \mathbb{R}^v$, i.e. the collection of injected powers as defined by (II.9) and $\Gamma := \text{diag}\{\gamma_k\} \in \mathbb{R}^{v \times v}$, a positive definite matrix. Then v^* verifies the power sharing property with respect to Γ if:

$$\Gamma \hat{P}_V(v^*) = \mathbf{1}_v. \quad (\text{IV.1})$$

This property consists in guaranteeing a given (proportional) power distribution among terminals in steady-state. A typical choice for the weights γ_k is the nominal power rating of the terminal. We now show that is possible to reformulate such a control objective as a set of quadratic constraints on the equilibrium point, assuming that it exists.

Lemma 4.2: Let $v^* = (v_P^*, v_V^*) \in \mathbb{R}^c$ be an equilibrium point for (II.18)-(II.19) and $\Gamma := \text{diag}\{\gamma_k\} \in \mathbb{R}^{v \times v}$ a positive definite matrix. Then v^* possesses the power sharing property with respect to Γ if and only if the quadratic equations

$$\frac{1}{2}(v^*)^\top \mathcal{A}_k^{\text{ps}} v^* + (\mathcal{B}_k^{\text{ps}})^\top v^* = p_k^{\text{ps}}, \quad k \sim \mathcal{E}_V, \quad (\text{IV.2})$$

where:

$$\mathcal{A}_k^{\text{ps}} := 2 \begin{bmatrix} 0 & 0 \\ 0 & \Gamma G_Z \end{bmatrix} e_k e_k^\top, \quad \mathcal{B}_k^{\text{ps}} := \begin{bmatrix} 0 \\ \Gamma \bar{u}_V \end{bmatrix} e_k e_k^\top, \quad p_k^{\text{ps}} := e_k^\top \begin{bmatrix} 0 \\ \Gamma P_V^* \end{bmatrix}$$

admit a solution.

An immediate implication of this lemma is given in the following proposition, which establishes necessary conditions for the existence of an equilibrium point that verifies the power sharing property.

Proposition 4.3: Consider the system (II.18)-(II.19), for some given P_P^* , P_V^* and Γ . Suppose that there exist three diagonal matrices $T_P \in \mathbb{R}^{p \times p}$, $T_V \in \mathbb{R}^{v \times v}$, $T_V^{\text{ps}} \in \mathbb{R}^{v \times v}$, such that:

$$\Upsilon(T_P, T_V) + \Upsilon_{\text{ps}}(T_V^{\text{ps}}) > 0, \quad (\text{IV.3})$$

with

$$\Upsilon_{\text{ps}} := \begin{bmatrix} 0 & 0 & 0 \\ \star & 2T_V^{\text{ps}} \Gamma G_Z & T_V^{\text{ps}} \Gamma \bar{u}_V \\ \star & \star & -2T_V^{\text{ps}} (\mathbf{1}_v - \Gamma P_V^*) \end{bmatrix}.$$

Then the system (II.18)-(II.19) does not admit an equilibrium point that verifies the power sharing property.

V. AN ILLUSTRATIVE EXAMPLE

In order to validate the results on existence of equilibria and power sharing for the system (II.18)-(II.19) we provide an illustrative example. Namely, we consider the four-terminal hvdc transmission system depicted in Fig. 2, the parameters of which are given in Table I. Since $c = t = 4$, the graph associated to the hvdc system has $n = 5$ nodes and $m = 8$ edges. We then make the following assumptions.

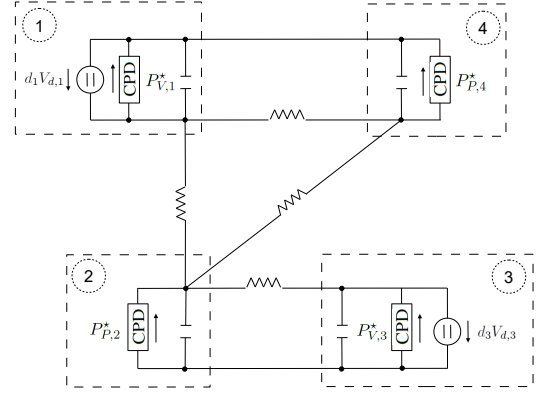

Fig. 2: Four-terminal hvdc transmission system.

- Terminal 1 (T1) and Terminal 3 (T3) are equipped with primary control. Hence, there are $p = 2$ PQ units and $v = 2$ voltage-controlled units. Moreover we take

$$\delta_k(v_{C,k}) = -d_k(v_{C,k} - v_C^{\text{nom}}), \quad k = \{1, 3\}.$$

This is the well-known *voltage droop control*, where d_k is a free control parameter, while v_C^{nom} is the nominal voltage of the hvdc system, see Remark 2.3.

- The power has to be shared equally among T1 and T3. Hence, $\Gamma = \mathbb{I}_2$ in Definition 4.1.

The next results are obtained by investigating the feasibility of the LMIs (III.3), (IV.3) as a function of the control parameters d_1 and d_3 . For this purpose, CVX, a package for specifying and solving convex programs, has been used to solve the semidefinite programming feasibility problem [23]. By using a gridding approach, the regions of the (positive) parameters that guarantee feasibility (yellow) and unfeasibility (blue) of the LMI (III.3) are shown in Fig. 3, while in Fig. 4 the same is done with respect to the LMI (IV.3). We deduce that a necessary condition for the existence of an equilibrium point is that the control parameters are chosen inside the blue region of Fig. 3. Similarly, a necessary condition for the existence of an equilibrium point that verifies the power sharing property is that the control parameters are chosen inside the blue region of Fig. 4.

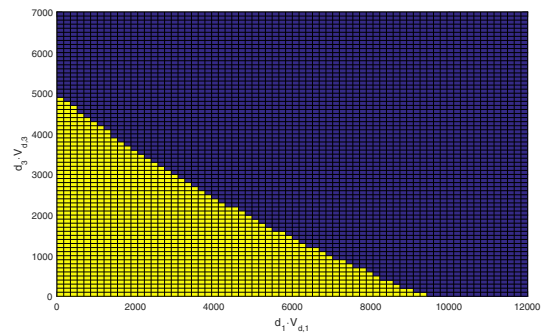

Fig. 3: Feasibility regions of the LMI (III.3) on the plane (d_1, d_3) of droop control parameters.

TABLE I: System parameters.

G_i	$0 \Omega^{-1}$	$P_{V,1}^*$	$30 MW$	$P_{P,2}^*$	$-20 MW$	$P_{V,3}^*$	$9 MW$	$P_{P,4}^*$	$-24 MW$
C_i	$20 \mu F$	G_{12}	$0.1 \Omega^{-1}$	G_{14}	$0.15 \Omega^{-1}$	G_{23}	$0.11 \Omega^{-1}$	G_{24}	$0.08 \Omega^{-1}$

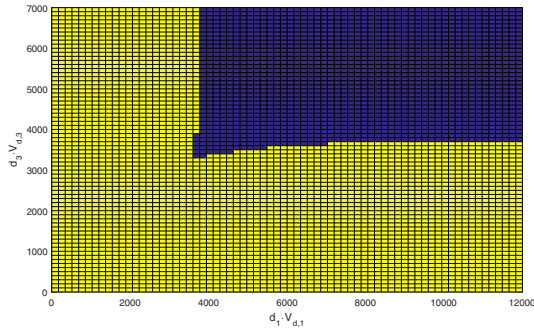

Fig. 4: Feasibility regions of the LMI (IV.3) on the plane (d_1, d_3) of droop control parameters.

VI. CONCLUSIONS AND FUTURE WORKS

In this paper, a new nonlinear model for primary control analysis and design has been derived. Primary control laws are described by equivalent ZIP models, which include the standard voltage droop control as a special case. A necessary condition for the existence of equilibria in the form of an LMI—which depends on the parameters of the controllers—is established, thus showing that an inappropriate choice of the latter may lead to non-existence of equilibria for the closed-loop system. The same approach is extended to the problem of existence of equilibria that verify the power sharing property. The obtained results are illustrated on a four-terminal example.

Future research will concern various aspects. First of all, a better understanding of how the feasibility of the LMIs are affected by the parameters is necessary. Since the established conditions depends on the network topology and the dissipation via the Laplacian matrix, this suggests that the location of the voltage-controlled units, as well as the network impedances, play a key role on the existence of equilibria. Similarly, it is of interest to understand how the ZIP coefficients affect the LMIs, in order to provide guidelines for the design of primary controllers. Further developments will focus on the establishment of conditions for the existence of equilibria in other scenarios: small deviations from the nominal voltage [9]; unit outages [4].

VII. ACKNOWLEDGMENTS

The authors acknowledge the support of the Future Renewable Electric Energy Distribution Management Center (FREEDM) and the Ministry of Education and Science of Russian Federation (Project14.Z50.31.0031).

REFERENCES

[1] A. Egea-Alvarez, J. Beerten, D. V. Hertem, and O. Gomis-Bellmunt, “Hierarchical power control of multiterminal HVDC grids,” *Electric Power Systems Research*, vol. 121, pp. 207 – 215, 2015.

[2] T. K. Vrana, J. Beerten, R. Belmans, and O. B. Fosso, “A classification of DC node voltage control methods for HVDC grids,” *Electric Power Systems Research*, vol. 103, pp. 137 – 144, 2013.

[3] M. Andreasson, M. Nazari, D. V. Dimarogonas, H. Sandberg, K. H. Johansson, and M. Ghandhari, “Distributed voltage and current control of multi-terminal high-voltage direct current transmission systems,” *IFAC Proceedings Volumes*, vol. 47, no. 3, pp. 11910–11916, 2014.

[4] J. Beerten and R. Belmans, “Analysis of power sharing and voltage deviations in droop-controlled DC grids,” *Power Systems, IEEE Transactions on*, vol. 28, no. 4, pp. 4588 – 4597, 2013.

[5] S. Shah, R. Hassan, and J. Sun, “HVDC transmission system architectures and control - a review,” in *Control and Modeling for Power Electronics, 2013 IEEE 14th Workshop on*, pp. 1–8, June 2013.

[6] T. Haileselassie, T. Undeland, and K. Uhlen, “Multiterminal HVDC for offshore windfarms – control strategy,” European Power Electronics and Drives Association, 2009.

[7] J. Zhao and F. Dörfler, “Distributed control and optimization in DC microgrids,” *Automatica*, vol. 61, pp. 18 – 26, 2015.

[8] N. Monshizadeh, C. D. Persis, A. van der Schaft, and J. M. A. Scherpen, “A networked reduced model for electrical networks with constant power loads,” *CoRR*, vol. abs/1512.08250, 2015.

[9] J. W. Simpson-Porco, F. Dörfler, and F. Bullo, “On resistive networks of constant-power devices,” *Circuits and Systems II: Express Briefs, IEEE Transactions on*, vol. 62, pp. 811–815, Aug 2015.

[10] N. Barabanov, R. Ortega, R. Grino, and B. Polyak, “On existence and stability of equilibria of linear time-invariant systems with constant power loads,” *Circuits and Systems I: Regular Papers, IEEE Transactions on*, vol. PP, no. 99, pp. 1–8, 2015.

[11] D. Zonetti, R. Ortega, and J. Schiffer, “A tool for stability and power sharing analysis of a generalized class of droop controllers for high-voltage direct-current transmission systems,” *ArXiv e-prints*, 2016.

[12] D. Zonetti, R. Ortega, and A. Benchaib, “Modeling and control of HVDC transmission systems from theory to practice and back,” *Control Engineering Practice*, vol. 45, pp. 133 – 146, 2015.

[13] A. Yazdani and R. Iravani, *Voltage-Sourced Controlled Power Converters – Modeling, Control and Applications*. Wiley IEEE, 2010.

[14] H. Akagi, *Instantaneous Power Theory and Applications to Power Conditioning*. Newark: Wiley, 2007.

[15] P. Sauer, “Time-scale features and their applications in electric power system dynamic modeling and analysis,” in *American Control Conference (ACC), 2011*, pp. 4155–4159, June 2011.

[16] J. Schiffer, D. Zonetti, R. Ortega, A. Stankovic, T. Sezi, and J. Raisch, “A survey on modeling of microgrids-from fundamental physics to phasors and voltage sources,” *Automatica*, *accepted*, 2016.

[17] A. van der Schaft, “Characterization and partial synthesis of the behavior of resistive circuits at their terminals,” *Systems & Control Letters*, vol. 59, no. 7, pp. 423 – 428, 2010.

[18] S. Fiaz, D. Zonetti, R. Ortega, J. Scherpen, and A. van der Schaft, “A port-Hamiltonian approach to power network modeling and analysis,” *European Journal of Control*, vol. 19, no. 6, pp. 477 – 485, 2013.

[19] E. Prieto-Araujo, F. Bianchi, A. Junyent-Ferré, and O. Gomis-Bellmunt, “Methodology for droop control dynamic analysis of multiterminal vsc-hvdc grids for offshore wind farms,” *Power Delivery, IEEE Transactions on*, vol. 26, pp. 2476–2485, Oct 2011.

[20] M. Belkhatay, R. Cooley, and A. Witulski, “Large signal stability criteria for distributed systems with constant power loads,” in *Power Electronics Specialists Conference, 1995. PESC '95 Record., 26th Annual IEEE*, vol. 2, pp. 1333–1338 vol.2, Jun 1995.

[21] A. Kwasinski and C. N. Onwuchekwa, “Dynamic behavior and stabilization of DC microgrids with instantaneous constant-power loads,” *Power Electronics, IEEE Transactions on*, vol. 26, pp. 822–834, 2011.

[22] S. Sanchez, R. Ortega, R. Grino, G. Bergna, and M. Molinas, “Conditions for existence of equilibria of systems with constant power loads,” *Circuits and Systems I: Regular Papers, IEEE Transactions on*, vol. 61, no. 7, pp. 2204–2211, 2014.

[23] M. Grant and S. Boyd, “CVX: Matlab software for disciplined convex programming, version 2.1.”