



Deposited via The University of Sheffield.

White Rose Research Online URL for this paper:

<https://eprints.whiterose.ac.uk/id/eprint/104584/>

Version: Accepted Version

Article:

O'Connor, D., Calautit, J.K. and Hughes, B.R. (2016) A Review of Heat Recovery Technology for Passive Ventilation Applications. *Renewable and Sustainable Energy Reviews*, 54. pp. 1481-1493. ISSN: 1879-0690

<https://doi.org/10.1016/j.rser.2015.10.039>

Reuse

This article is distributed under the terms of the Creative Commons Attribution-NonCommercial-NoDerivs (CC BY-NC-ND) licence. This licence only allows you to download this work and share it with others as long as you credit the authors, but you can't change the article in any way or use it commercially. More information and the full terms of the licence here: <https://creativecommons.org/licenses/>

Takedown

If you consider content in White Rose Research Online to be in breach of UK law, please notify us by emailing eprints@whiterose.ac.uk including the URL of the record and the reason for the withdrawal request.

A Review of Heat Recovery Technology for Passive Ventilation Applications

Highlights:

- 1) The limiting factor for using heat recovery technology in passive ventilation is the pressure loss across heat exchangers and the inconsistency of wind speed for passive ventilation
- 2) The main obstacle in integrating heat recovery into a passive ventilation system is the high pressure loss associated with heat exchangers
- 3) Previous studies have investigated heat recovery devices focussing on efficiency, but have not highlighted the potential for integration into passive ventilation systems
- 4) The heat recovery devices are compared by general advantages and disadvantages, efficiency range, pressure drop, humidity control and energy saving potential
- 5) Further research is necessary to understand the integration of heat recovery systems in passive ventilation to maximise the energy saving.

Abstract

A review of current heat recovery devices was undertaken in an attempt to determine the major factors preventing the integration of heat recovery technology into passive ventilation systems. The increase in space heating and cooling demand in recent years combined with statutory requirements to reduce greenhouse gas emissions in the UK requires technology to be as efficient as possible, consuming the lowest amount of energy necessary. Heat recovery technology can meet this demand by lowering the energy demand necessary for heating and cooling by pre-heating or pre-cooling. Six different heat recovery devices were analysed and compared for suitability for integration into passive ventilation systems. Heat pipes and rotary thermal wheels are suggested as the technologies with the most potential for integration due to high thermal efficiency and low pressure loss across the heat recovery device in comparison to the other technologies. High efficiency is necessary to recover the maximum amount of thermal energy available. Low pressure loss across the heat exchanger

is required to maintain adequate ventilation rates. The integration of heat recovery technology into passive ventilation has the potential to reduce energy demand in buildings but further research is required to optimise the recovery devices for simple installation, high efficiency and low pressure loss.

Keywords: heat recovery, passive ventilation, low energy, heat pipes; rotary thermal wheel

1 Introduction

At present the UK government is committed to a statutory requirement to cut greenhouse gas emissions by 80% of pre-1990 levels by 2050 (1). The operation and maintenance of buildings now consumes up to 40% of the total energy demand globally (2, 3). Heating, Ventilation and Air-Conditioning, commonly referred to as HVAC, consumes 40-60% of the energy demand of a building, depending on the local climate (4-6). The design of more efficient processes and equipment will lead to a reduction in energy demand but such equipment must still be capable of meeting strict thermal comfort and ventilation guidelines (7). Ghaffarian Hoseini *et al.* (72) reviewed recent literature to understand what makes a green building successful and a formula for future design was developed. The study concluded that the concerns of successful green buildings need to be accounted for by architects, engineers and developers in order to maximise savings.

By reducing the thermal losses of a building, the energy demand for heating will reduce. At present, the most common method of reducing thermal losses is to increase the airtightness of the building to reduce air infiltration and increase the insulation of the building envelope (8). However, increasing the airtightness of a building envelope and reducing the infiltration of outdoor air can have a negative effect on the indoor air quality (IAQ) of a building. This can have a negative effect on the performance and health of occupants (9, 10).

For IAQ to be maintained above safe levels of pollutant concentration, ventilation must be undertaken in a controlled manner to maintain both thermal comfort conditions and adequate ventilation rates whilst not affecting building airtightness. This is difficult to accomplish in cold climates during winter when using passive ventilation systems due to draughts causing discomfort to occupants (11).

Heat recovery is a method which is increasingly used to reduce the heating and cooling demands of buildings. Building exhaust air is used as either a heat source or heat sink depending on the climate conditions, time of year and requirements of the building (12). The thermal energy in the exhaust air can be transferred to the incoming fresh air, thereby raising the temperature and reducing the heating demand in the heating season. During the cooling season, the exhaust air can be used as a heat sink for the thermal energy in the warmer incoming fresh air, thereby reducing the cooling demand.

These systems have been shown to provide a significant reduction of energy demand on the HVAC systems of buildings (13, 14). In the UK, indoor air temperature has increased by 3°C over the previous decades, requiring a 20% increase in heating energy consumption (4). Using heat recovery devices to transfer the temperature to the incoming air and raise the temperature would save considerable energy. Behavioural changes in occupants and the high electrical consumption in many office and service sector buildings have resulted in internal heat gains from electrical equipment that is considerable. The temperature increases from these heat gains provide a reliable heat source which could be recovered consistently by a heat recovery device, reducing the reliance of heating systems.

Ventilation of a building using passive or natural methods is a commonly used technique which is gaining significant popularity due to the low running costs and improved indoor environments for occupants. A combination of low energy ventilation and heat recovery technology is advantageous for building operators due to the potential for high cost savings. Furthermore, the reduced environmental impact will be attractive to governing bodies who are keen to decrease greenhouse gas emissions.

Though simulations and calculations provide engineers and developers an indication of the performance of a building, this does not necessarily align with the measured performance. A study of the discrepancy between the calculated building performance and measured performance of a naturally ventilated building was completed by Roetzel *et al.* (73). It was found that providing thermal comfort to occupants through the use of space heating and air-conditioning, that these processes consume the most energy in buildings in cold and hot climates respectively but also that they provide the largest scope for reduction in energy demand. Natural ventilation can provide thermal comfort to occupant but is dependent on the difference between the outdoor and room air temperature. As these two parameters can be closely linked, during summer months when the two temperatures are similar, the effect of cooling and providing thermal comfort will be reduced. However, it was found that occupants in naturally ventilated buildings are able to tolerate higher room temperatures in summer than those in buildings which are air-conditioned. This is due to the level of personal control afforded to occupants in naturally ventilated buildings. Along with the influence of occupant controlled natural ventilation causing discrepancies between calculated and measured building performance, the climate data used for calculation was found to be ineffective. The majority of climate data does not factor in the urban heat island effect which can increase temperatures in urban areas significantly. This leads to increased cooling demand in summer and reduced heating demand in winter.

Saadatian *et al.* (74) provided a detailed exploration of the working mechanisms of wind towers; the buoyancy effect, and wind driven flow. It was found that the wind driven flow was the most important variable in determining the ventilation rate. Furthermore, the team looked at the attributes, configurations and technologies which provided the most advantage and efficiency. Multi-directional, square or rectangular shaped wind towers with louvers angled at 35° and using egg crate grilles and dampers were found to be the most efficient design for maximising and controlling air flow rate through the wind tower.

Dehghani-sanij *et al.* (75) reviewed the recent developments for passive wind towers. A significant number of alternative designs to conventional square, four-sided wind towers were explored. Wind towers were found to be effective at delivering ventilation to buildings and reducing energy consumption, suggestions for alternative designs and materials were given to improve the efficiency and usability of wind towers.

Ventilation in atriums is a significant research area due to the large air volume of the atrium and the way in which they connect a building. Moosavi *et al.* (76) investigated the building design parameters of atriums with the objective of gaining understanding for improved designs for natural ventilation which would result in better energy efficiency. Atriums offer a central space to residential and non-residential buildings which provide air circulation and communication around the building. Natural ventilation techniques are used to provide the optimum indoor air circulation and thermal comfort without the reliance on mechanical HVAC systems. Though initially designed in buildings located in temperate climates, modern atriums, which feature high levels of glazing and metalwork, are commonly constructed in climates which do not suit the design style and so become dependent on mechanical process to deliver thermal comfort, thereby increasing the energy consumption.

At present, few heat recovery devices have been integrated into passive ventilation systems. These systems are zero energy that deliver supply air into buildings and provide a suitable basis of creating a low energy ventilation and heat recovery system. This paper investigates the current heat recovery technology and ongoing research activities within the field with the goal to summarise the advantages and disadvantages of various heat recovery devices and assess the potential integration into passive ventilation systems based on common criteria.

2 Heat Recovery Ventilation (HRV) Devices

Thermal energy can be defined by two different form; sensible and latent heat. Sensible heat is the dry air temperature which can be recovered. Latent heat is the energy that is recovered from the moisture within the airstream. Sensible only heat recovery devices

generally have lower efficiency than total energy recovery devices which are capable of recovering sensible and latent heat (8, 15, 16).

Previous studies have investigated heat recovery devices from an efficiency standpoint but have not highlighted the potential for integration into passive ventilation systems (12).

Mardiana-Idayu and Riffat (17) included the analysis of heat recovery in passive ventilation systems. Their work concluded that various heat recovery devices were appropriate for both passive and mechanical ventilation depending on the specifics of each ventilation process design. Heat pipe heat recovery units were determined the most effective for passive ventilation due to the lack of moving parts in the system; heat pumps were most commonly used for mechanical ventilation systems and rotary thermal wheels were widely used for dehumidification of airstreams. It was noted that little work had been conducted in the area of combining of heat recovery and low carbon technologies such as evaporative cooling and desiccant dehumidification.

More recently, Cuce and Riffat (77) took a detailed view of heat recovery systems for building applications, theoretical, experimental and simulation analysis as well as thermodynamic performance assessment. The review looked at the technology as a whole and predominately focussed on the integration into mechanical ventilation systems and even noted the high energy costs that can be associated due to the need for fans to overcome the addition pressure loss of the heat recovery devices. Overall, it was noted that heat recovery systems are designed to reduce the energy consumed for heating, cooling and ventilation in buildings by recovering waste heat.

Shi and Chew (78) analysed solar-based energy systems, ground source-based systems and day-lighting systems, which make use of heat recovery technology, in order to determine which parameters most strongly affected the efficiency of each system. For solar-based energy systems, the orientation of the building and the system itself have a significant effect on the efficiency along with local weather conditions, tilt angle, surface temperature and system selection. The depth to which they are buried and the size of ground source-

based systems are key to the operating capacity. Day-lighting systems are largely dependent on the weather conditions. The arrangement of day-lighting systems, roof mounted or side mounted, has significant impact on the effectiveness. This is in addition to the material used, size and shape of the device.

Chan *et al.* (79) investigated passive solar heating and cooling technologies, discussing each according to the working mechanism, advantages, limitation and challenges. Trombe wall, solar chimneys, solar façades and solar roofs were all examined as well as evaporative cooling. It was recommended that further research be undertaken to improve the technologies with particular interest in the system efficiency, architectural aesthetic and cost effectiveness. A combined system that was capable of delivering heating and cooling was recommended to be the most effective.

2.1 Rotary Thermal Wheels

Rotary thermal wheels are a mechanical means of heat recovery. A rotating porous metallic wheel transfers thermal energy from one air stream to another by passing through each fluid alternately. The system operates by working as a thermal storage mass whereby the heat from the air is temporarily stored within the wheel matrix until it is transferred to the cooler air stream (17). This is demonstrated in the schematic diagram in Figure 1.

Figure 1 – Working principle of wheel heat recovery unit (18)

A number of numerical investigations have been completed in order to conceptually optimise the design of rotary thermal wheels (19-23). Mathematical models were developed in order to calculate a number of factors of the performance of rotary wheels which were then compared against experimental laboratory work or existing literature. The mathematical models focussed on the heat and moisture transfer through the wheel matrices, the effect of rotation speed on the temperature of air streams and the individual analysis of a single channel within the honeycombed structure of the matrix. Figure 2 shows the effect of air

velocity on the pressure drop across a 100mm thick wheel and the influence of an entrance region factor on the calculation. Hemzal (24) carried out experimental research which focussed on the pressure drop in rotary thermal wheels and the effect it had on air flow. The data presented below showed that the pressure drop across the wheel increases as the air velocity increases. This makes the integration into passive ventilation systems difficult as the lack of driving forces to overcome pressure loss leads to low ventilation supply rates.

Figure 2 – Relationship between pressure drop and air superficial velocity (21)

Two types of rotary thermal wheel exist, heat wheels and enthalpy (desiccant) wheels. Though there is geometrical similarity between heat and enthalpy wheels, there are differences which effect the operation of each design. In a system utilising a desiccant wheel, the moisture in the airstream with the highest relative humidity is transferred to the opposite airstream after flowing through the wheel. This can work in both directions of incoming air to exhaust air and exhaust air to incoming air. The supply air can then be used directly or employed to further cool the air, this is an energy intensive process. Zhang and Niu (25) found that the optimum rotation speed for a desiccant wheel for dehumidification is significantly lower than a heat wheel as increased contact time is necessary for the adsorption of the water molecules on to the surface of the desiccant material.

At present, rotary thermal wheels are commonly used in mechanical ventilation systems to recover the energy from the exhaust air. The total efficiency of rotary thermal wheels is generally above 80%. Juodvalkis *et al.* (26) noted that in mechanical ventilation systems, rotary thermal wheels are commonly coupled with a rotary heat pump. This is done to improve the overall performance of the system for recovery and heating. Calay and Wang (27) found that due to the efficient method of moisture removal in enthalpy wheels, they are usually used as a centralised method of air treatment. This method of air treatment is capable of energy savings of up to 60% compared to existing systems. Figure 3a demonstrates that a hybrid system using a rotary thermal wheel, is capable of delivering

ventilation with lower input energy compared to an air conditioning system across a range of outdoor air temperatures. Furthermore, the hybrid system delivers air that is cooler and so has greater thermal comfort for occupants at high outdoor air temperatures, as shown in Figure 3b. Further studies show that systems incorporating a rotary thermal wheel are capable of saving significant amounts of energy. In a climate with a high heating degree days value such as Sweden, savings of up to 30-42kWh.m⁻² are possible, as shown by Akbari and Oman (28).

Figure 3 – Effect of outdoor air temperature (a) on input energy required, and (b) on fresh air temperature (27)

Rotary thermal wheels have a number of disadvantages that limits the use for heat recovery applications. Rotary thermal wheels are susceptible to parasitic shortcuts, where air moving in one direction recirculates in an unintended direction, known as air short circuiting.

Furthermore, cross contamination of the air streams is a significant factor in the placement of rotary thermal wheels. Roulet *et al.* (29) stated that although seals and purge selectors can reduce the impact of short circuiting and cross contamination, it does not completely remove the problem, making rotary thermal wheels unsuitable for hospitals and other buildings where isolated air streams must be maintained. Furthermore, because of the high pressure loss experienced across rotary thermal wheels, additional fans are used to maintain high air flow rates into buildings for ventilation. If these fans require more power to operate than is recovered, energy is lost from the system.

Ge *et al.* (80) studied solar powered rotary desiccant wheel cooling systems which were separated into two classifications. Separate solar rotary desiccant wheel cooling system and a hybrid system where mechanical vapour compression systems are used for cooling of the airstream. The authors noted that the moisture removal capacity of both classifications of systems is high but the cooling capacity is limited by the cooling technology employed. Both classifications are suitable for use in climates which are hot and humid. Little experimental

and far-field testing have been completed which would be beneficial for design and improving simulation models which are primarily used for analysis.

2.2 Fixed Plate Exchangers

Fixed plate heat exchangers are the most commonly used type of heat exchanger and have been developed for 40 years (17, 30). Thin metal plates are stacked with a small spacing between plates. Two different airstreams pass through these spaces, adjacent to each other. The heat transfer occurs as the temperature transfers through the plate from one airstream to the other. The efficiency of these devices has been shown to be extremely high in transferring sensible heat from one air stream to another. Nielsen *et al.* (31) have noted values of 90% sensible heat efficiency. The high levels of efficiency are attributed to the high heat transfer coefficients of the materials used, operational pressure and temperature range. The core of fixed plate heat exchangers can be arranged in a number ways for the airstreams to move through. Cross, concurrent and counter-current flow arrangements are the most common configurations of fixed plate core. Lamb (32) stated that fixed plate heat exchangers operate best under counter-current flow conditions. However, the configuration of counter-current flow fixed plate heat exchangers required substantially more space for ducts and installation than concurrent flow exchangers. Nasif *et al.* (33) developed a solution to overcome this problem, both concurrent and counter-current flow arrangements were incorporated into one design, as shown in Figure 4. This solution reduces the space required of a standard concurrent flow arrangement but still allows the two airstreams to pass counter-current over a substantial amount of the heat exchanger.

Figure 4 – Heat exchanger plastic frame flow channels (33)

Zhang (34) compared corrugated plates to flat plates which are traditionally used in fixed plate heat exchangers, as seen in Figure 5. It was theorised that triangular ducts would provide a higher transfer compared to standard flat plates as the mixing effect in the ducts

would be intensified in the troughs and thinner material thickness could be used due to the increased strength, aiding transport. There were difficulties in modelling the design in CFD due to the frequent transition from laminar to turbulent flow even at low Reynolds numbers, a low Reynolds $k-\omega$ model was used to satisfactorily solve this problem.

Figure 5 – The flow channel geometry for corrugated fixed plate heat exchangers (34)

A common problem that exists with the use of fixed plate heat exchangers is the build-up of condensation within the structure. If the air is cooled below the dew point temperature during the heat transfer to the opposite airstream, condensation will form. Fernandez-Seara *et al.* (35) reported that this build-up of condensation can seriously reduce the thermal performance and efficiency of the heat exchanger. Further to this, in climates with external temperatures which regularly fall below 0°C, frost and ice formation within the heat exchanger due to the condensate can block the air pathways, preventing the exchanger from operating. Kragh *et al.* (36) developed a solution to this problem by designing a fixed plate heat exchanger which continuously alternated between two modes of operation to prevent the build-up of frost and ice. The new design maintained good operating conditions, even when the external air temperature was significantly below 0°C. The temperature efficiency was measured as 82%.

2.3 Membrane fixed plate exchanger

Though metals and alloys are the most common materials used in fixed plate heat exchangers, research interest is now significantly focussed on porous membranes which are capable of transferring both sensible and latent heat. Yaici *et al.* (37) used porous membranes as a material for total energy recovery devices. The results from this study showed that sensible and latent heat recovery is possible with membrane modelling across a fixed plate heat exchanger. Figure 6 shows the schematic of a membrane fixed plate exchanger. The membrane is supported between two layers in order to provide structure to

the plates; the supports do not interfere with heat or mass transport. Al-Waked *et al.* (38) performed CFD modelling of the membrane heat exchangers and showed that total energy recovery from fixed plate heat exchangers is an efficient process, transferring heat and moisture through convection and conduction.

Figure 6 – Schematic of a membrane-based energy recovery ventilator: (a) core in counter flow arrangement; (b) schematic of the physical model in a co-current and counter flow arrangements (37).

Research conducted by Zhang (39) has shown that Supported Liquid Membranes (SLM) are a promising area of membrane based fixed plate heat exchanger due to the ability to transfer heat and mass. Zhang and Xiao (40) showed that SLM have a moisture diffusivity coefficient of up to 3-4 orders of magnitude higher than solid membranes; allowing for greater moisture transfer and recovering more latent heat than traditional metal/ alloy fixed plates. From research completed by the same group (41) and Min and Su (42), it was determined from a study of different plate materials and characteristics that the plate thickness is the defining factor in the efficiency of the heat exchanger along with channel height between the plates. Zhang and Jiang (16) also found that for reliable performance, the pressure difference across the exchanger must be high with high membrane intensity. Nui and Zhang (43) noted that the efficiency of this form of recovery is similar to highly effective enthalpy rotary wheels but do not have the problems of frost and condensation common with rotary wheels.

2.4 Heat Pipes

Heat pipes are a heat recovery device that use a multi-phase process to transfer heat from one airstream to another (44). Heat is transferred using an evaporator and condenser within a wicked, sealed pipe containing a fluid which undergoes constant phase change to transfer heat. The fluid within the pipes changes from a fluid to a gas in the evaporator section, absorbing the thermal energy from the warm airstream. The gas condenses back to a fluid in the condenser section where the thermal energy is dissipated into the cooler airstream raising the temperature. The fluid/gas is transported from one side of the heat pipe to the

other through pressure, wick forces or gravity, depending on the arrangement of the heat pipe as shown in Figure 7.

Figure 7 – Schematic representation of heat-pipe heat recovery unit in operation (45)

Srimuang and Amatachaya (81) investigated the application of heat pipes for heat recovery. The work documented the advantages for energy saving and reduced greenhouse gas emissions in industrial applications and potential applications in other sectors.

Liu *et al.* (7) reported that heat pipes are an effective method of heat transfer with a varying level of efficiency depending on the fluid mixture used. Two airstreams can be completely separated with zero risk of the flows mixing, this prevents cross-contamination. No moving parts within the systems results in high reliability, low maintenance and a compact system. As the fluid is free to flow around the heat pipes, the system is capable of recovering heat in both directions, cooling or warming air as necessary depending on the indoor and climatic conditions. Finned pipes provide the highest efficiency and as there are no moving parts and no noise levels, heat pipes are suitable choices of heat recovery devices.

Theoretical and experimental research into heat pipes has been conducted by a number of teams. Gan and Riffat (45) conducted CFD analysis to understand the causes of pressure loss within a heat pipe heat recovery system. The most obvious cause of pressure loss is due to the blockage caused by the physical presence of heat pipes in the ducts which is further increased by finned pipes and smaller spacing. An indirect cause of pressure loss comes from the reduced temperature difference between the supply and exhaust air streams after the heat recovery.

Hughes *et al.* (46) completed CFD modelling to determine the most effective arrangement of heat pipes. Both the pitch and distance between heat pipes along with a horizontal or vertical arrangement to determine which arrangement resulted in the highest heat recovery. Using pure water as the phase change material in the pipes, the distance between the heat pipes relative to each other was altered as well as the number of rows. With the optimal pattern of

heat pipes determined as a pitch of 0.035m between centres, pre-cooling recovery was calculated at 15.6°C in hot, dry climates. Pre-heating was calculated at 3.3°C across the heat pipes for a milder climate. Using these values for pre-conditioning air with zero energy input, a significant energy reduction can be attained using heat pipes in a ventilation system.

Calautit *et al.* (47) used a similar methodology when modelling heat pipes in a vertical and horizontal arrangement with the pattern described above. This analysis yielded similar results in terms of temperature drop. Reductions in internal flow rate of 7% and 10% were observed when the heat pipes were arranged in a vertical and horizontal arrangement respectively. Whilst the reduction in internal flow rate is noticeable, it is not significant enough to prevent proper supply rates being provided into a conditioned space.

El-Baky and Mohamed (48) indicated that as the outdoor air temperature increases, the temperature change for both the inlet and exhaust air increases. This led to the conclusion that the optimum effectiveness of a heat pipe is achieved when the fresh air temperature is close to the operating temperature of the heat pipe fluid.

2.5 Run-around

Run-around systems are a hybrid heat recovery system that incorporates characteristics from other heat recovery technology to form a single device, capable of recovering heat from one air stream and delivering to another a significant distance away. Vali *et al.* (49) showed the general case of run-around heat recovery, two fixed plate heat exchangers are located in two separate airstreams and are linked by a closed loop containing a fluid which is continually pumped between the two heat exchangers. The fluid is heated and cooled constantly as it flows around the loop, providing the heat recovery, as shown in Figure 8. The constant flow of the fluid through the loop requires pumps to move between the two heat exchangers. Though this is an additional energy demand, using pumps to circulate fluid is less energy intensive than fans to circulate air.

Figure 8 – Schematic diagram of a run-around heat recovery system (49)

Hviid and Svendsen (50) designed a simple system to experimentally test the pressure loss of a run-around heat recovery system. It was shown that using two separate air-to-liquid heat exchangers connected by a liquid loop, a pressure loss of 0.74Pa could be attained for a system with 75.6% temperature efficiency. It was shown that the frictional losses within the fluid loop are the most significant factor for determining the size and energy consumption of the pump needed. This work was furthered by Davidsson *et al.* (51) by increasing the efficiency of the systems for a small increase in pressure loss. A temperature efficiency of 80% was made possible with a 1Pa pressure loss measured across the heat exchanger. This demonstrated that efficient heat recovery in passive ventilation systems may be possible by limiting pressure loss.

A number of attempts to improve the design of run-around systems have been conducted by focussing on the fixed plate heat exchangers used in the system. Using a membrane based core in the fixed plate heat exchangers, Mahmud *et al.* (52) found that a total effectiveness of the system of 50-55% was achievable. Because a membrane fixed plate heat exchanger was used, both the heat and water vapour were transferred through the micro-porous layer. A different study by Wallin *et al.* (53) used a coil heat exchanger in place of the fixed plate heat exchanger and also compared the efficiency of a variable capacity heat pump. The coil heat exchanger increased efficiency from 47% to 65% and the variable capacity heat pump increased the efficiency to 66%.

The combination of a cross and counter-flow plate heat exchanger, as discussed previously, was incorporated into a numerical model of a run-around heat recovery system by Vali *et al.* (49). The new system design was validated against published literature and was accurate to $\pm 2.5\%$ for both individual exchangers and a system as a whole.

Due to the large size and necessary equipment for the installation of the equipment, retrofit of existing buildings to integrate run-around systems is difficult and expensive. However

Emerson (54) showed that early integration into building design can alleviate these problems. Wang (55) stated that this is the most efficient and economical method of designing in a passive ventilation system with run-around heat recovery. Furthermore, these systems contain the heat recovery system within the ductwork that would normally be associated with mechanical ventilation, adding no substantial architectural features to the building.

2.6 Phase Change Materials

Phase change materials, commonly referred to as PCMs, are a technology that is used to store sensible and latent heat within a building structure at a higher storage capacity than standard building materials. PCMs have been studied extensively due to the ability to store heat and transfer heating and cooling demands from conventional peak times to off-peak times. Reviews by Baetens *et al.* and Farid *et al.* (56, 57) on the type of heat storage, classification of PCMs, suitability in buildings and applications give a broad understanding of PCMs.

Parameshwaran *et al.* (82) analysed thermal energy storage systems in significant detail. Thermal energy storage systems offer the ability to transfer heating and cooling energy from peak time to off-peak times, reducing energy consumption. The expense of integrating thermal energy storage systems can be offset the earlier that the systems are integrated into building design. The types of technology, chiefly latent heat energy storage (LHES) and cool thermal energy storage (CTES), the research being undertaken, the integration of the technology architecturally, performance assessments of buildings utilising thermal energy storage systems were all explored. An outline for effective use of thermal energy storage systems in high performance buildings was recommended.

Kelly (58) reported that phase change materials can be classified into three main groups; organic compounds, inorganic compounds and inorganic eutectics. Each of these groups has different characteristics which are advantageous and disadvantageous for heat storage

applications. PCMs store and release thermal energy by cycling between solid and liquid states as the ambient temperature fluctuates; this process is shown in Figure 9. As the temperature rises, the materials changes from solid to liquid, this process is endothermic and so absorbs heat from the ambient air, reducing the local air temperature. As the air temperature reduces, the PCM solidifies and the thermal energy is output to the environment, increasing the local temperature.

Figure 9 – Schematic diagram of heat transfer process of PCMs

This showcases the potential for PCMs to alter the ambient air temperature to more comfortable levels for occupants by cooling or heating the air in a reactive way to climate conditions. Kauranen *et al.* (59) noted that the melting and freezing temperatures of the PCMs must be carefully matched to the local climate conditions to ensure the maximum efficiency from the system. The different groups of PCMs have a wide range of melting and freezing points, as shown in Figure 10. It is beneficial to select the appropriate group for the local climate. Organic PCMs are generally chemically stable, non-corrosive, non-toxic, do not suffer from supercooling and have a high latent heat of fusion. The most common organic PCM is paraffin wax. It is an inexpensive PCM which has a wide range of melting temperatures, 20-70°C, depending on the composition. However, due to low thermal conductivity and large volume change there is limited application for paraffin waxes. Inorganic PCMs are phase change materials that are not naturally occurring, such as hydrated salts, but have properties that make them suitable to store and transfer thermal energy. A high heat of fusion, good thermal conductivity and inexpensive material costs suggest that inorganic PCMs are the ideal material for thermal storage. However, they are corrosive to metals and undergo supercooling and phase decomposition. Eutectic mixtures are multiple solids in various ratios to keep the melting point as low as possible.

Figure 10 – The melting enthalpy and melting temperature for the different groups of phase change materials. (56)

The concept of thermal mass of a building for heat storage, that the physical structure of the building absorbs heat to help cool the air, has long been understood and investigated. A study by Feldman *et al.* (60) of PCMs in comparison to traditional building materials has shown that the thermal storage capacity of PCMs is twelve times higher than standard building materials over the same temperature range.

The pressure drop across PCMs has not been investigated to be able to comment on the effect that the material may have on airstreams. However, as the PCM can be incorporated directly into the building structure, this would not affect the flow in the same way other heat exchanger technologies do, it can be suggested that there is no pressure loss created by the inclusion of PCMs in the building fabric.

3 Applications of HRV in Passive Ventilation

3.1 Application of rotary thermal wheel

O'Connor *et al.* (61) studied the effect that a rotary thermal wheel has on the supply air flow rates in to a building. A computational model was created to simulate the effects of a rotary thermal wheel on air flow rates when incorporated into a commercial wind tower system. The simulation was validated with a scale model experiment in a closed-loop subsonic wind tunnel. The data obtained from both tests were compared in order to analyse the flow rates. Although the flow rates were reduced compared to a wind tower which did not include a rotary thermal wheel, the guideline ventilation rates for occupants in a school or office building were met above an external wind speed of 3m/s, which is lower than the average wind speed of the UK (4-5m/s). The calculated air supply rates are shown in Figure 11 and compared with the guideline supply rate.

Figure 11 – Comparison of air supply rate for a wind tower and a wind tower with a rotary thermal wheel against the guideline supply rate of 8l/s/p. (61)

No full scale experimental or field test data was completed in this study; therefore it cannot be conclusively proved that rotary thermal wheels are feasible for integration into a commercial wind tower system. However, despite the air flow rates decrease within the building after the introduction of the rotary thermal wheel, the reduction was not large enough to prevent the ventilation guideline rates being met.

Sufficient research has not yet been conducted to determine the suitability of rotary thermal wheels in natural ventilation, ventilation supply rates can be met but the thermal capabilities of the rotary thermal wheel have not yet been investigated. Further work would be beneficial to increase understanding of the system.

3.2 Application of fixed plate heat exchangers

Mardiana *et al.* (62) integrated a fixed plate heat exchanger into a commercial wind tower, highlighting the advantages of this type of system as a means of zero energy ventilation which can be simply modified. Full scale laboratory testing was undertaken in order to determine the effects and efficiency of the combined system. A wind tower was integrated with a fixed plate heat exchanger and was mounted centrally on a sealed test room. The experimental setup can be seen in Figure 12.

Figure 12 – The schematic diagram of experimental chamber and total dimension (62)

The results showed a number of factors were important to the efficient operation of the fixed plate heat exchanger. A maximum temperature change of 5.1°C and 4.6°C were measured for the cold and warm air inlet streams respectively. Though an increase in temperature change was noted as the air velocity was increased from 1.2m/s to 3.1m/s for the warm and cold air inlet conditions, the efficiency of the heat exchanger in both conditions reduced. The efficiency reduced from 70% to 50% and 69% to 49% from 1.2m/s to 3.1m/s for the cold and warm air inlet streams respectively. This was due to the shorter contact time between the air and the heat exchanger as a result of the increased air velocity. It was observed from the

experimentation that for the warm inlet air, the air temperature reduced as it entered the wind tower. This enhances the system's profile as a means of providing thermal comfort in a warm environment.

The pressure loss across the heat exchanger was measured as the inlet air velocity increased. Pressure loss increased from 7Pa to 30Pa from an inlet air velocity of 1.2m/s to 3.1m/s. Ventilation rates were not investigated in the paper however, due to the high pressure loss it is likely that a significant reduction in air supply rates would occur.

The results from this study indicate that the combination of a wind tower passive ventilation system and a fixed plate heat recovery device could provide an effective combined technology to recover waste heat from exhaust air and cool incoming warm air with zero energy demand. Though no quantitative data for the ventilation rates within the test room was provided, it can be assumed that due to the high pressure loss across the heat exchanger that these were significantly reduced from standard operation of a wind tower. Further investigation of this combined of technology is essential in understanding the air flow characteristics of the system.

3.3 Application of heat pipes

Due to the low pressure loss of heat pipe systems, more research has been conducted into the integration of this technology into passive ventilation than other heat recovery systems. Commercial wind towers were again used as the passive ventilation system for integrating this heat recovery technology. This further enhances the suggestion that commercial wind towers provide a worthwhile alternative to mechanical ventilation, capable of supplying and exhausting air at the same time.

Shao *et al.* (63) investigated the use of heat pipes in a passive stack ventilation system. A laboratory model was conducted, using lamps and lighting bulbs for heat generation within the model building structure. A range of four different heat pipes with different internal fins were tested in order to determine which was the most effective heat transfer device over a

range of inlet air velocities. It was found that louvered fins within a heat pipe provided the most efficient heat transfer compared to the other prototypes over the range of air velocities. Further to this, it was noted that increasing air velocity had a negative effective on the thermal efficiency of the heat pipes. As velocity increased, the efficiency decreased.

Calautit *et al.* (64) used CFD analysis to determine the effectiveness of heat pipes in reducing air temperature in a single sided wind tower with varying tower height and different fluid type within the heat pipes. Water and ethanol were the two types of fluid that were tested within the heat pipes during the analysis. Based on the measured heat transfer rates to the evaporator and cooler, water provided better temperature reduction and heat transfer compared to ethanol. The variation in the wind tower height was not a significant factor in the change in air temperature experienced as air flowed down the wind tower. A more compact system using a smaller tower has the same efficiency as a taller tower. The arrangement of horizontal heat pipes within the wind tower reduced the incoming air temperature by 12-15K with a small pressure loss of 5Pa across the heat pipe heat exchangers as can be seen in Figure 13.

Figure 13 – Temperature contour lines of a cross sectional plane in the test channel; (a) evaporative cooling (b) heat pipe device (64)

Riffat and Gan (65) conducted a comprehensive study of heat pipes for heat recovery in passive ventilated buildings. A laboratory experiment containing a passively ventilated two zone chamber was constructed which ran alongside a CFD model of the same geometry and dimensions. The CFD model determined that the low pressure loss across the heat pipes was difficult to measure in the laboratory experiment. Three different types of heat pipe were tested in various configurations. The results from the study showed that plain finned pipes in a staggered arrangement were the most efficient at transferring heat from one air stream to the other, similar to the arrangement used by Calautit *et al.* (64). Finned pipes that were arranged in a single line were less efficient due to the reduced contact time between the heat pipes and the air. Though the results presented the optimum configuration of the heat

pipes, it was noted that the pressure loss across the bank of heat pipes was the limiting factor in delivering adequate ventilation.

This work was continued by the same team, who then investigated the effect of a solar chimney on the ventilation and heat recovery (66). By using a solar chimney to warm the air through different glazing options, it was found that the ventilation rate increased as the chimney wall temperature increased. However, when heat pipes were included in the design in an attempt to recover the thermal energy in the air, it was found that the thermal buoyancy effect was reduced, limiting the ventilation rates. Because of this finding, it was concluded that buoyancy driven passive ventilation in a building would require manipulation of external wind forces to drive ventilation.

3.4 Application of run-around systems

Flaga-Maryanczyk *et al.* (67) conducted a study in Sweden which examined a passive ventilation system which integrated a run-around system using a ground source heat pump as the heat source to warm incoming air. A schematic of the design is shown in Figure 14.

Figure 14 – The schematic view of the ventilation system in the passive house (67)

Experimental measurements and weather data were taken from the passive house used in the study. A CFD model of the passive house was created with the measurements taken from the sensors and weather station used as input data. The model was run to calculate the effectiveness of the run-around system and the capabilities of the ground source heat pump.

Ground source heat pumps provide a reliable source of consistent thermal energy when buried 10-20m below the ground surface. The ground temperature is warmer than ambient air in winter and cooler than ambient air in summer, providing both heat source and heat sink. It was found that in February, the coldest month in the climate, that the ground source heat pump was capable of delivering almost 25% of the heating needs of the house and occupants.

3.5 Application of phase change materials

The majority of research interest in PCMs is the application of phase change material integration into traditional porous building materials such as concrete and wallboards. Kosny *et al.* (68) analysed the thermal performance of buildings which have PCM-enhanced construction materials within the structure. Analysis showed that the addition of PCMs is beneficial in terms of improving the thermal performance.

PCMs can be added to building materials either through direct incorporation at the mixing level or by immersing the building materials in PCMs. Feldman *et al.* (60) found that direct incorporation is the preferred method of addition as only one additional step is required to the mixing process of the materials and shows better heat storage. Though PCMs have a large potential for heat storage, poor thermal conductivity limit the heat transfer rates which are attainable. The enhancement of the heat transfer potential of PCMs was explored by Velraj *et al.* (69) and Stritih (70). Various methods to increase the charge/discharge rate of heat were investigated by the addition of modifying components compared to standard PCMs. Modifying the components increased the charge/discharge rate of the PCMs, the addition of fins within the PCM was found to be the most influential modification.

At present, the use of PCMs in passive ventilation systems is extremely limited. The only significant application is the Cool-Phase ventilation system. The Cool-Phase system, shown in Figure 15 is a hybrid ventilation system which uses PCMs in thermal batteries to cool incoming air from the external environment before diffusing it into the occupied spaces. The system relies on mechanical, low energy fans to circulate the air through the ducts and across the PCM thermal batteries. The system is quoted as capable of reducing energy use by 90% by replacing conventional HVAC systems which require more energy intensive processes (71).

Figure 15 – Schematic diagram of operation of Cool-Phase system (71)

A significant drawback of PCM use in a passive ventilation system for heat recovery is the lack of instantaneous heat transfer across different airstreams. Phase change materials are a heat storage technology, whereby the heat is stored within the PCM until the air temperature has fallen to a significant level where it can be released back into the air stream. No research has been conducted into the use of PCMs between two airstreams of different temperature where continuous, instantaneous heat transfer can occur. An investigation into this area would be beneficial for passive ventilation heat recovery research.

4 Summary

A summary of the heat recovery technology explored in this work has been collated in Table 1. The heat recovery devices are compared by general advantages and disadvantages, efficiency range, pressure drop, humidity control and energy saving potential. Analysing the heat recovery devices in this way means that the most suitable selection for integration into passive ventilation systems can be completed more easily.

Table 1 – Summary and details of heat recovery devices

Heat recovery is an emerging technology which has the potential to significantly reduce the energy demand for heating and cooling within buildings by recovering energy from exhaust air in winter months for heating and cooling incoming air in summer months. A number of heat recovery technologies currently exist which transfer heat in different of ways.

Integration of heat recovery technology into passive ventilation systems relies on the pressure drop across the heat exchanger remaining as low as possible to prevent reduction in air supply rates. This is one of the primary concerns for researchers in this field, alongside the efficiency of the heat recovery device. Secondary to these are humidity control, ease of integration and size.

The review of current literature in this study suggests that the heat recovery devices with the most potential for integration into passive ventilation systems are rotary thermal wheels and heat pipes.

All heat recovery technologies are currently disadvantaged by the high pressure drop experienced when air moves across/through them. CFD analysis has shown the heat pipes have a low pressure drop across the exchanger when the pipes are positioned in an optimised arrangement. Rotary heat wheels, through the use of scale model testing and CFD analysis, have a pressure loss of similar magnitude to heat pipes at low inlet air velocity. Though run-around systems have a low pressure drop, the large ducting and arrangement of the system is unsuitable for passive ventilation. Furthermore, the low efficiency of the system prevents worthy energy savings due to the energy required by the pumps to move the fluid around the system.

To maximise energy savings, efficient transfer of heat is required. Heat pipes and rotary thermal wheels provide the highest temperature efficiency. Rotary thermal wheels also provide the added benefit of latent heat recovery and moisture control. Latent heat recovery has been shown to increase the effectiveness of heat recovery devices when coupled with sensible heat recovery.

Rotary wheels and heat pipes can be further enhanced by focussed research into the design of each system. With further research and development of the matrix structure, optimal length of the wheel and the rotation speed, the pressure drop across the wheel may be reduced to levels where passive ventilation is capable at higher inlet air velocities. Heat pipes are capable of high heat transfer rates with moderately low pressure loss compared to other technology. Further research into the optimum shape and arrangement of heat pipes would provide a suitable technology for integration into passive ventilation systems. Both systems are capable of transferring energy in both directions, summer cooling and winter heating would be possible within a single system providing year round ventilation and thermal comfort.

5 Conclusion

A review of the current heat recovery technology literature has been conducted, identifying the key parameters which affect performance; the efficiency of each technology, the pressure loss cause by the technology and whether the system is capable of humidity control. The purpose of this review was to determine which technology, if any, would be suitable for integration into passive ventilation systems.

Passive ventilation offers a zero-energy system to provide adequate ventilation into buildings. The savings made on electrical demand by replacing HVAC systems with passive ventilation have been shown elsewhere. By coupling passive ventilation and heat recovery, an opportunity exists to significantly reduce energy use for ventilation, heating and cooling by using heat recovery technology to condition the incoming air to thermal comfort levels desired by the occupants.

Of the heat recovery technologies reviewed, rotary wheels and heat pipes are the most feasible options for integrating into passive ventilation systems. High efficiency and the ability to transfer both sensible and latent heat are advantageous. The most important factor when considering the heat recovery technology to integrate into passive ventilation is

pressure loss experienced across the heat exchanger. Due to the low velocity of airstreams in passive ventilation systems, the pressure loss must be kept as low as possible in order to maintain adequate ventilation rates.

Though the present design of rotary thermal wheels and heat pipes do not fulfil the criteria required for integration into passive ventilation systems, further research is being undertaken to make this possible. Redesign of the structure of rotary wheels is being conducted and tested to lower the pressure drop whilst maintaining the effectiveness. Finding the optimum positioning of the heat pipes would lower the pressure drop, along with altering the shape of the heat pipes. Further study of these parameters will lead to an integrated passive ventilation system with heat recovery, resulting in a system capable of lowering the energy consumption of a number of types of building in a number of climates.

6 Acknowledgements

The authors would like to thank the School of Mechanical Engineering at the University of Sheffield for their support and financial aid in funding this project.

7 References

1. DECC. *Climate Change Act*. London, 2008.
2. TOMMERUP, H. and S. SVENDSEN. Energy savings in Danish residential building stock. *Energy and Buildings*, 2006, **38**(6), pp.618-26.
3. LIDDAMENT, M.W. and M. ORME. Energy and ventilation. *Applied Thermal Engineering*, 1998, **18**(11), pp.1101-1109.
4. WBCSD. *Energy Efficiency in Buildings: Facts & Trends*. Switzerland 2008.
5. ORME, M. Estimates of the energy impact of ventilation and associated financial expenditures. *Energy and Buildings*, 2001, **33**(3), pp.199-205.
6. PEREZ-LOMBARD, L., J. ORTIZ and C. POUT. A review on buildings energy consumption information. *Energy and Buildings*, 2008, **40**(3), pp.394-398.
7. LIU, D., F.-Y. ZHAO and G.-F. TANG. Active low-grade energy recovery potential for building energy conservation. *Renewable and Sustainable Energy Reviews*, 2010, **14**(9), pp.2736-2747.
8. GENDEBIEN, S., S. BERTAGNOLIO and V. LEMORT. Investigation on a ventilation heat recovery exchanger: Modeling and experimental validation in dry and partially wet conditions. *Energy and Buildings*, 2013, **62**, pp.176-189.

9. MUMOVIC, D., J. PALMER, M. DAVIES, M. ORME, I. RIDLEY, T. ORESZCZYN, C. JUDD, R. CRITCHLOW, H.A. MEDINA, G. PILMOOR, C. PEARSON and P. WAY. Winter indoor air quality, thermal comfort and acoustic performance of newly built secondary schools in England. *Building and Environment*, 2009, **44**(7), pp.1466-1477.
10. CLEMENTS-CROOME, D.J., H.B. AWBI, Z. BAKO-BIRO, N. KOCHHAR and M. WILLIAMS. Ventilation rates in schools. *Building and Environment*, 2008, **43**(3), pp.362-367.
11. JONES, B.M. and R. KIRBY. Indoor air quality in U.K. school classrooms ventilated by natural ventilation windcatchers. *International Journal of Ventilation*, 2012, **10**(4), pp.323-338.
12. SAUER JR, H.J. and R.H. HOWELL. Promise and potential of air-to-air energy recovery systems. *International Journal of Refrigeration*, 1981, **4**(4), pp.182-194.
13. DODOO, A., L. GUSTAVSSON and R. SATHRE. Primary energy implications of ventilation heat recovery in residential buildings. *Energy and Buildings*, 2011, **43**(7), pp.1566-72.
14. KE, Z. and K. YANMING. Applicability of air-to-air heat recovery ventilators in China. *Applied Thermal Engineering*, 2009, **29**(5-6), pp.830-40.
15. RASOULI, M., C.J. SIMONSON and R.W. BESANT. Applicability and optimum control strategy of energy recovery ventilators in different climatic conditions. *Energy and Buildings*, 2010, **42**(9), pp.1376-85.
16. ZHANG, L.Z. and Y. JIANG. Heat and mass transfer in a membrane-based energy recovery ventilator. *Journal of Membrane Science*, 1999, **163**(1), pp.29-38.
17. MARDIANA-IDAYU, A. and S.B. RIFFAT. Review on heat recovery technologies for building applications. *Renewable and Sustainable Energy Reviews*, 2012, **16**(2), pp.1241-1255.
18. ZOU, T., L. MA and Y. XUE. Experimental Study on the Performance of rotary heat recovery unit. In: *2010 Asia-Pacific Power and Energy Engineering Conference (APPEEC 2010)*, 28-31 March 2010, Piscataway, NJ, USA. IEEE, 2010, p.4 pp.
19. NOBREGA, C.E.L. and N.C.L. BRUM. Modeling and simulation of heat and enthalpy recovery wheels. *Energy*, 2009, **34**(12), pp.2063-2068.
20. WU, Z., R.V.N. MELNIK and F. BORUP. Model-based analysis and simulation of regenerative heat wheel. *Energy and Buildings*, 2006, **38**(5), pp.502-514.
21. YAMAGUCHI, S. and K. SAITO. Numerical and experimental performance analysis of rotary desiccant wheels. *International Journal of Heat and Mass Transfer*, 2013, **60**, pp.51-60.
22. ZHANG, X.J., Y.J. DAI and R.Z. WANG. A simulation study of heat and mass transfer in a honeycombed rotary desiccant dehumidifier. *Applied Thermal Engineering*, 2003, **23**(8), pp.989-1003.
23. ANGRISANI, G., C. ROSELLI and M. SASSO. Effect of rotational speed on the performances of a desiccant wheel. *Applied Energy*, 2013, **104**(0), pp.268-275.
24. HEMZAL, K. Rotary heat exchanger efficiency influenced by air tightness. In: *17th Air-Conditioning and Ventilation Conference*, Praha. 2006.
25. ZHANG, L.Z. and J.L. NIU. Performance comparisons of desiccant wheels for air dehumidification and enthalpy recovery. *Applied Thermal Engineering*, 2002, **22**(12), pp.1347-1367.

26. JUODVALKIS, J., E. BLAZEVICIUS, J. KARBAUSKAITE and V. NENORTA. Rotary heat pump. *Mechanika*, 2011, (5), pp.535-9.
27. CALAY, R.K. and W.C. WANG. A hybrid energy efficient building ventilation system. *Applied Thermal Engineering*, 2013, **57**(1-2), pp.7-13.
28. AKBARI, K. and R. OMAN. Impacts of heat recovery ventilators on energy savings and indoor radon in a swedish detached house. *WSEAS Transactions on ENVIRONMENT and DEVELOPMENT*, 2013, **9**(1).
29. ROULET, C.A., F.D. HEIDT, F. FORADINI and M.C. PIBIRI. Real heat recovery with air handling units. *Energy and Buildings*, 2001, **33**(5), pp.495-502.
30. FEHRM, M., W. REINERS and M. UNGEMACH. Exhaust air heat recovery in buildings. *International Journal of Refrigeration*, 2002, **25**, pp.439-449.
31. NIELSEN, T.R., J. ROSE and J. KRAGH. Dynamic model of counter flow air to air heat exchanger for comfort ventilation with condensation and frost formation. *Applied Thermal Engineering*, 2009, **29**(2-3), pp.462-8.
32. LAMB, B.R. PLATE HEAT EXCHANGERS - A LOW-COST ROUTE TO HEAT RECOVERY. *Journal of heat recovery systems*, 1982, **2**(3), pp.247-255.
33. NASIF, M., R. AL-WAKED, G. MORRISON and M. BEHNIA. Membrane heat exchanger in HVAC energy recovery systems, systems energy analysis. *Energy and Buildings*, 2010, **42**(10), pp.1833-40.
34. ZHANG, L.-Z. Convective mass transport in cross-corrugated membrane exchangers. *Journal of Membrane Science*, 2005, **260**(1-2), pp.75-83.
35. FERNANDEZ-SEARA, J., R. DIZ, F.J. UHIA, A. DOPAZO and J.M. FERRO. Experimental analysis of an air-to-air heat recovery unit for balanced ventilation systems in residential buildings. *Energy Conversion and Management*, 2011, **52**, pp.635-640.
36. KRAGH, J., J. ROSE, T.R. NIELSEN and S. SVENDSEN. New counter flow heat exchanger designed for ventilation systems in cold climates. *Energy & Buildings*, 2007, **39**(11), pp.1151-8.
37. YAICI, W., M. GHORAB and E. ENTCHEV. Numerical analysis of heat and energy recovery ventilators performance based on CFD for detailed design. *Applied Thermal Engineering*, 2013, **51**(1-2), pp.770-80.
38. AL-WAKED, R., M.S. NASIF, G. MORRISON and M. BEHNIA. CFD simulation of air to air enthalpy heat exchanger. *Energy Conversion and Management*, 2013, **74**, pp.377-385.
39. ZHANG, L.-Z. Heat and mass transfer in plate-fin enthalpy exchangers with different plate and fin materials. *International Journal of Heat and Mass Transfer*, 2009, **52**(11-12), pp.2704-2713.
40. ZHANG, L.-Z. and F. XIAO. Simultaneous heat and moisture transfer through a composite supported liquid membrane. *International Journal of Heat and Mass Transfer*, 2008, **51**(9-10), pp.2179-2189.
41. ZHANG, L.-Z., C.-H. LIANG and L.-X. PEI. Heat and moisture transfer in application scale parallel-plates enthalpy exchangers with novel membrane materials. *Journal of Membrane Science*, 2008, **325**(2), pp.672-682.
42. MIN, J. and M. SU. Performance analysis of a membrane-based energy recovery ventilator: Effects of membrane spacing and thickness on the ventilator performance. *Applied Thermal Engineering*, 2010, **30**(8-9), pp.991-997.

43. NIU, J.L. and L.Z. ZHANG. Membrane-based Enthalpy Exchanger: Material considerations and clarification of moisture resistance. *Journal of Membrane Science*, 2001, **189**(2), pp.179-191.
44. LIN, S., J. BROADBENT and R. MCGLEN. Numerical study of heat pipe application in heat recovery systems. *Applied Thermal Engineering*, 2005, **25**(1), pp.127-133.
45. GAN, G. and S.B. RIFFAT. Naturally ventilated buildings with heat recovery: CFD simulation of thermal environment. *Building Services Engineering Research and Technology*, 1997, **18**(2), pp.67-75.
46. HUGHES, B.R., H.N. CHAUDHRY and J.K. CALAUTIT. Passive energy recovery from natural ventilation air streams. *Applied Energy*, 2014, **113**(0), pp.127-140.
47. CALAUTIT, J.K., B.R. HUGHES, H.N. CHAUDHRY and S.A. GHANI. CFD analysis of a heat transfer device integrated wind tower system for hot and dry climate. *Applied Energy*, 2013, **112**(0), pp.576-591.
48. ABD EL-BAKY, M.A. and M.M. MOHAMED. Heat pipe heat exchanger for heat recovery in air conditioning. *Applied Thermal Engineering*, 2007, **27**(4), pp.795-801.
49. VALI, A., C.J. SIMONSON, R.W. BESANT and G. MAHMOOD. Numerical model and effectiveness correlations for a run-around heat recovery system with combined counter and cross flow exchangers. *International Journal of Heat and Mass Transfer*, 2009, **52**(25-26), pp.5827-5840.
50. HVIID, C.A. and S. SVENDSEN. Analytical and experimental analysis of a low-pressure heat exchanger suitable for passive ventilation. *Energy and Buildings*, 2011, **43**(2-3), pp.275-84.
51. DAVIDSSON, H., R. BERNARDO and B. HELLSTROM. Theoretical and experimental investigation of a heat exchanger suitable for a hybrid ventilation system. *Buildings*, 2013, **3**, pp.18-38.
52. MAHMUD, K., G.I. MAHMOOD, C.J. SIMONSON and R.W. BESANT. Performance testing of a counter-cross-flow run-around membrane energy exchanger (RAMEE) system for HVAC applications. *Energy and Buildings*, 2010, **42**(7), pp.1139-1147.
53. WALLIN, J., H. MADANI and J. CLAEISSON. Run-around coil ventilation heat recovery system: A comparative study between different system configurations. *Applied Energy*, 2012, **90**(1), pp.258-265.
54. EMERSON, W.H. DESIGNING RUN-AROUND COIL SYSTEMS. *Journal of heat recovery systems*, 1983, **3**(4), pp.305-309.
55. WANG, J.C.Y. PRACTICAL THERMAL DESIGN OF RUN-AROUND AIR-TO-AIR HEAT RECOVERY SYSTEM. *Journal of heat recovery systems*, 1985, **5**(6), pp.493-501.
56. BAETENS, R., B. JELLE and A. GUSTAVSEN. Phase change materials for building applications: A state-of-the-art review. *Energy and Buildings*, 2010, **42**(9), pp.1361-8.
57. FARID, M.M., A.M. KHUDHAIR, S.A.K. RAZACK and S. AL-HALLAJ. A review on phase change energy storage: materials and applications. *Energy Conversion and Management*, 2004, **45**(9-10), pp.1597-1615.
58. KELLY, R. *Latent heat storage in building materials* [online]. 1997. [Accessed 27 February 2014]. Available from: <http://www.amec.com>.
59. KAURANEN, P., K. PEIPPO and P.D. LUND. An Organic PCM Storage-System with Adjustable Melting Temperature. *Solar Energy*, 1991, **46**(5), pp.275-278.

60. FELDMAN, D., D. BANU and D.W. HAWES. Development and Application of Organic-Phase Change Mixtures in Thermal Storage Gypsum Wallboard. *Solar Energy Materials and Solar Cells*, 1995, **36**(2), pp.147-157.
61. O'CONNOR, D., B. HUGHES and J.K. CALAUTIT. A Study of Passive Ventilation Integrated with Heat Recovery. *Energy and Buildings*, 2014, **82**(1), pp.799-811.
62. MARDIANA, A., S.B. RIFFAT and M. WORALL. Integrated heat recovery system with wind-catcher for building applications: towards energy-efficient technologies. A. Mendez-Vilas (Ed.), *Materials and processes for energy: communicating current research and technological developments*, Formatex Research Center, Badajoz, 2013.
63. SHAO, L., S.B. RIFFAT and G. GAN. Heat recovery with low pressure loss for natural ventilation. *Energy and Buildings*, 1998, **28**(2), pp.179-184.
64. CALAUTIT, J.K., H.N. CHAUDHRY, B.R. HUGHES and S.A. GHANI. Comparison between evaporative cooling and a heat pipe assisted thermal loop for a commercial wind tower in hot and dry climatic conditions. *Applied Energy*, 2013, **101**(1), pp.740-755.
65. RIFFAT, S.B. and G. GAN. Determination of effectiveness of heat-pipe heat recovery for naturally-ventilated buildings. *Applied Thermal Engineering*, 1998, **18**(3-4), pp.121-130.
66. GAN, G. and S.B. RIFFAT. A numerical study of solar chimney for natural ventilation of buildings with heat recovery. *Applied Thermal Engineering*, 1998, **18**(12), pp.1171-1187.
67. FLAGA-MARYANCZYK, A., J. SCHNOTALE, J. RADON and K. WAS. Experimental measurements and CFD simulation of a ground source heat exchanger operating at a cold climate for a passive house ventilation system. *Energy and Buildings*, 2014, **68**(A), pp.562-570.
68. KOSNY, J., D. YARBROUGH, W. MILLER, T. PETRIE, P. CHILDS, A.M. SYED and D. LEUTHOLD. Thermal performance of PCM-enhanced building envelope systems. *In: Thermal Performance of the Exterior Envelopes of Whole Buildings X, Proceedings of the ASHRAE/DOE/BTECC Conference*, December 2-7, Clear Water Beach, FL. 2007, pp.1-8.
69. VELRAJ, R., R.V. SEENIRAJ, B. HAFNER, C. FABER and K. SCHWARZER. Heat transfer enhancement in a latent heat storage system. *Solar Energy*, 1999, **65**(3), pp.171-180.
70. STRITIH, U. Heat transfer enhancement in latent heat thermal storage system for buildings. *Energy and Buildings*, 2003, **35**(11), pp.1097-1104.
71. MONODRAUGHT. *Cool-Phase - Natural Cooling and Low Energy Ventilation* [online]. 2014. [Accessed 13 March 2014]. Available from: <http://www.cool-phase.net/>.
72. GHAFFARIAN HOSEINI, A., N. DALILAH DAHLAN, U. BERARDI, A. GHAFFARIAN HOSEINI, N. MAKAREMI and M. GHAFFARIAN HOSEINI. Sustainable energy performances of green buildings: A review of current theories, implementations and challenges. *Renewable and Sustainable Energy Reviews*, 2013, **25**(1), pp.1-17.
73. ROETZEL, A., A. TSANGRASSOULIS, U. DIETRICH and S. BUSCHING. A review of occupant control on natural ventilation. *Renewable and Sustainable Energy Reviews*, 2010, **14**(3), pp.1001-1013

74. SAADATIAN, O., L.C. HAW, K. SOPIAN and M.Y. SULAIMAN. Review of windcatcher technologies. *Renewable and Sustainable Energy Reviews*, 2012, **16**(3), pp.1477-1495.
75. DEHGHANI-SANIJ, A.R., M. SOLTANI and K. RAAHEMIFAR. A new design of wind tower for passive ventilation in buildings to reduce energy consumption in windy regions. *Renewable and Sustainable Energy Reviews*, 2015, **42**(1), pp.182-195.
76. MOOSAVI, L., N. MAHYUDDIN, N. AB GHAFAR and M. AZZAM ISMAIL. Thermal performance of atria: An overview of natural ventilation effective designs. *Renewable and Sustainable Energy Reviews*, 2014, **34**(1), pp.654-670.
77. CUCE, P.M. and S. RIFFAT. A comprehensive review of heat recovery systems for building applications. *Renewable and Sustainable Energy Reviews*, 2015, **47**(1), pp.665-682.
78. SHI, L. and M.Y.L. CHEW. A review on sustainable design of renewable energy systems. *Renewable and Sustainable Energy Reviews*, 2012, **16**(1), pp.192-207.
79. CHAN, H.Y., S.B. RIFFAT and J. ZHU. Review of passive solar heating and cooling technologies. *Renewable and Sustainable Energy Reviews*, 2010, **14**(2), pp.781-789.
80. GE, T.S., Y.J. DAI and R.Z. WANG. Review on solar powered rotary desiccant wheel cooling system. *Renewable and Sustainable Energy Reviews*, 2014, **39**(1), pp.476-497.
81. SRIMUANG W. and P. AMATACHAYA. A review of the applications of heat pipe heat exchangers for heat recovery. *Renewable and Sustainable Energy Reviews*, 2012, **16**(6), pp.4303-4315.
82. PARAMESHWARAN R., S. KALAISELVAM, S. HARIKRISHNAN and A. ELAYAPERUMAL. Sustainable thermal energy storage technologies for buildings: A review. *Renewable and Sustainable Energy Reviews*, 2012, **16**(5), pp.2394-2433.

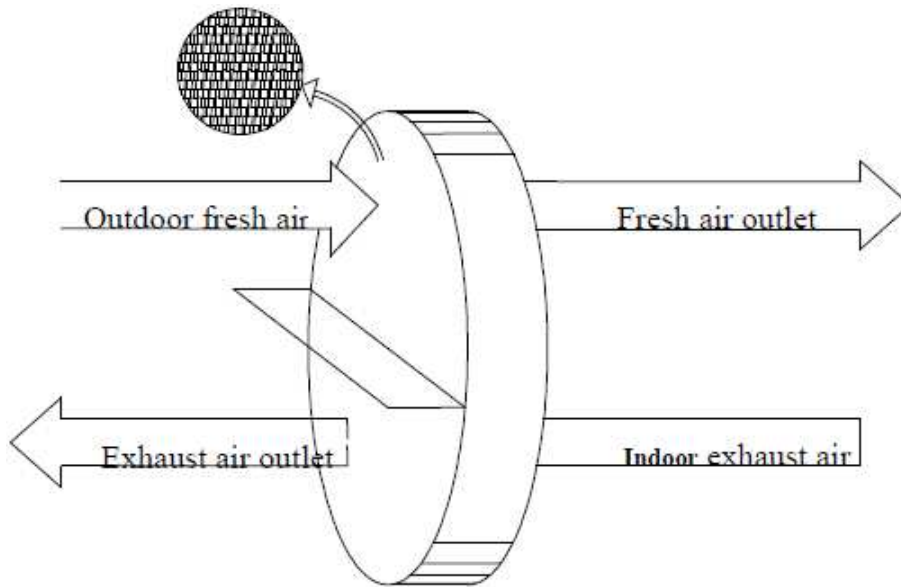

Figure 1 – Working principle of wheel heat recovery unit (18)

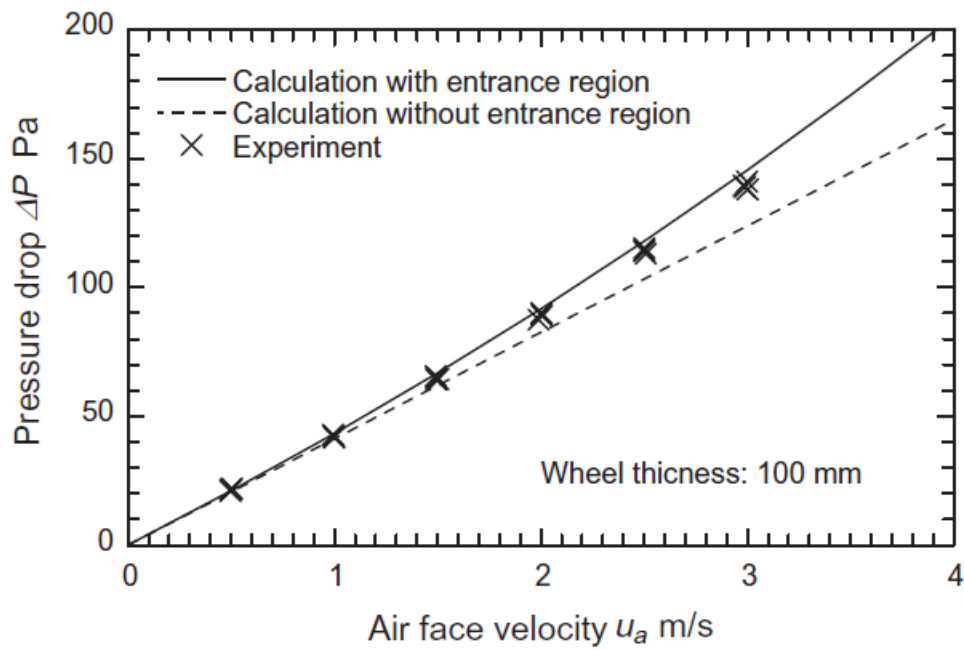

Figure 2 – Relationship between pressure drop and air superficial velocity (21)

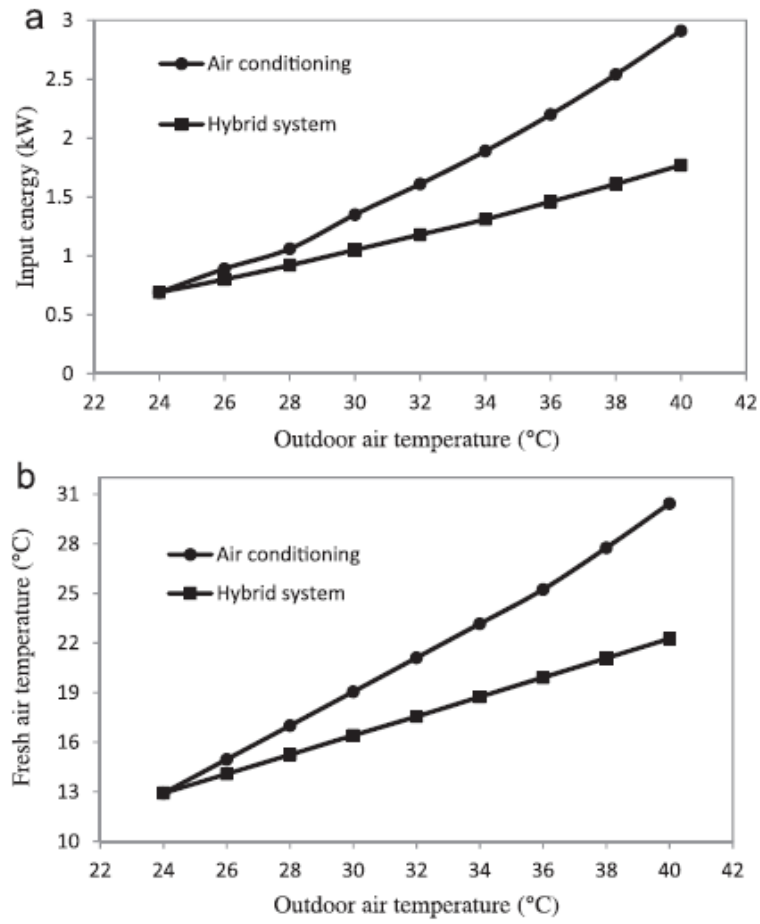

Figure 3 – Effect of outdoor air temperature (a) on input energy required, and (b) on fresh air temperature

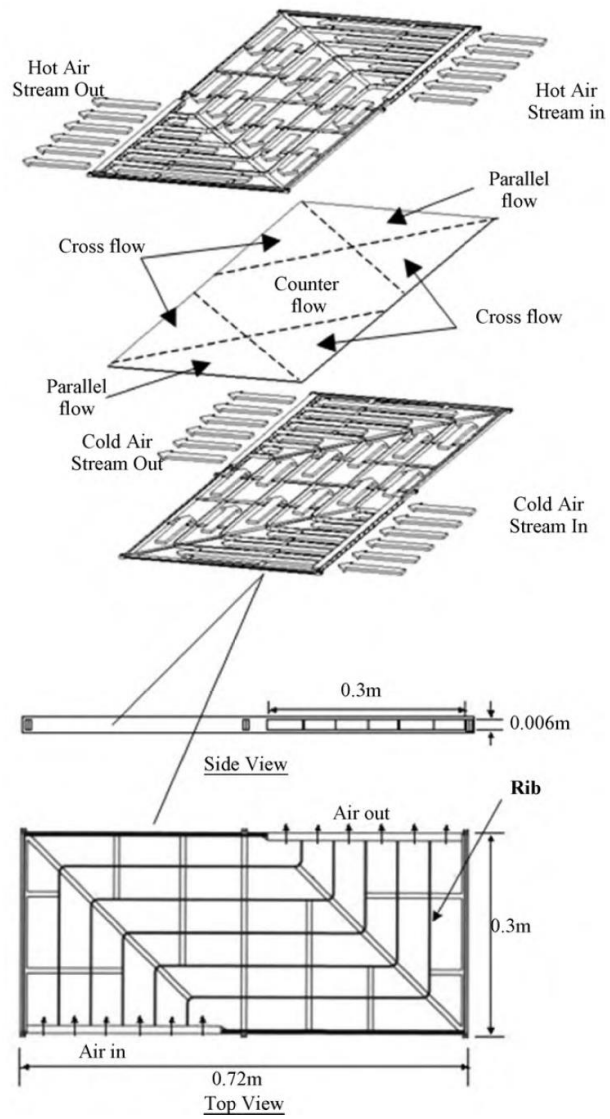

Figure 4 – Heat exchanger plastic frame flow channels (33)

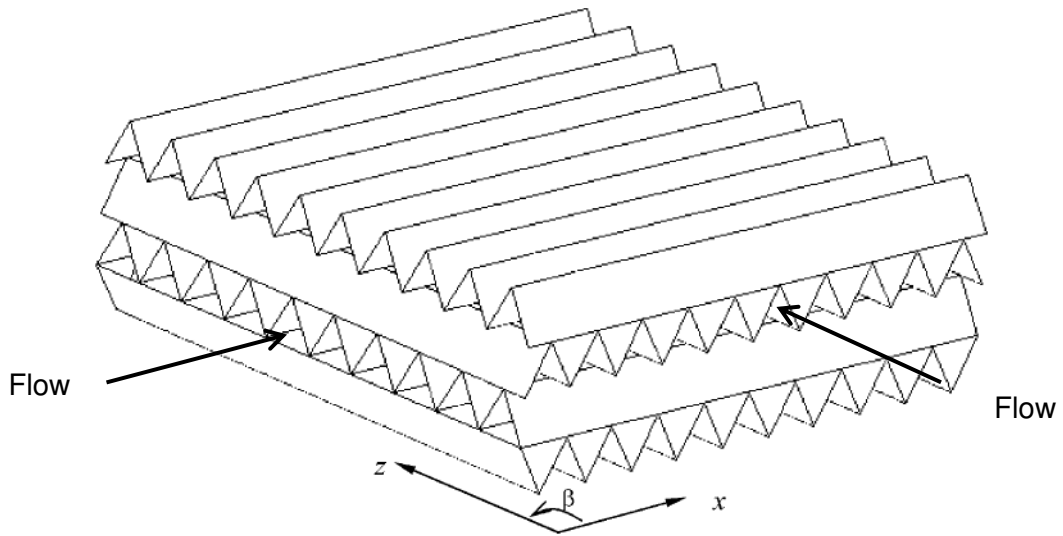

Figure 5 – The flow channel geometry for corrugated fixed plate heat exchangers (34)

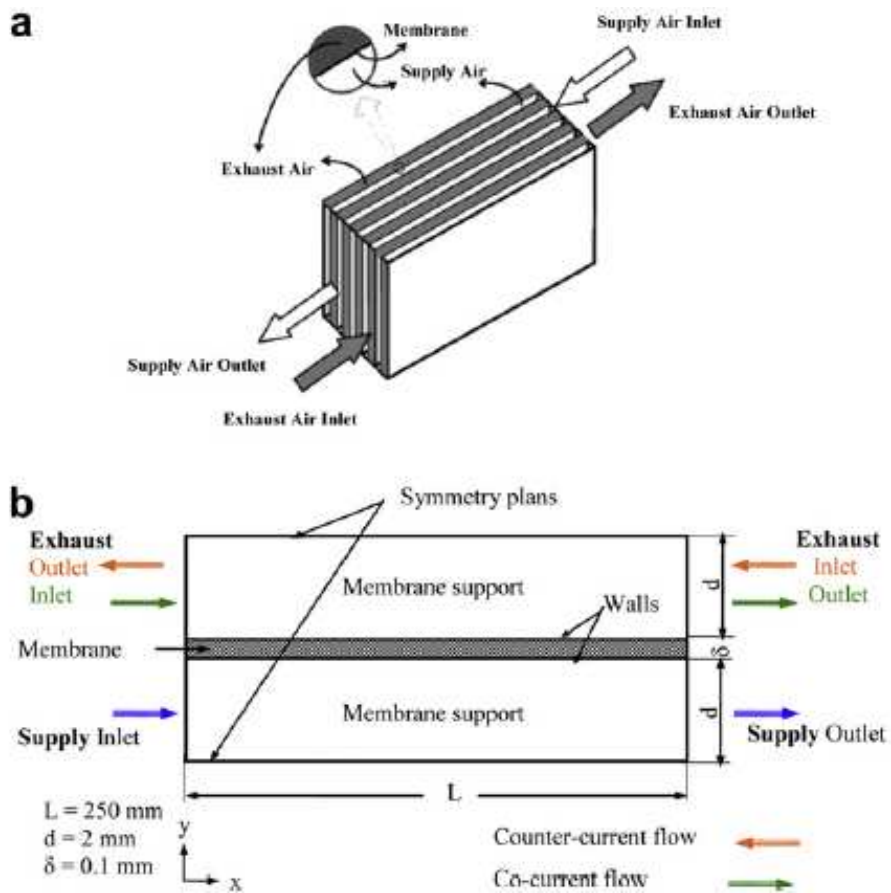

Figure 6 – Schematic of a membrane-based energy recovery ventilator: (a) core in counter flow arrangement; (b) schematic of the physical model in a co-current and counter flow arrangements (37).

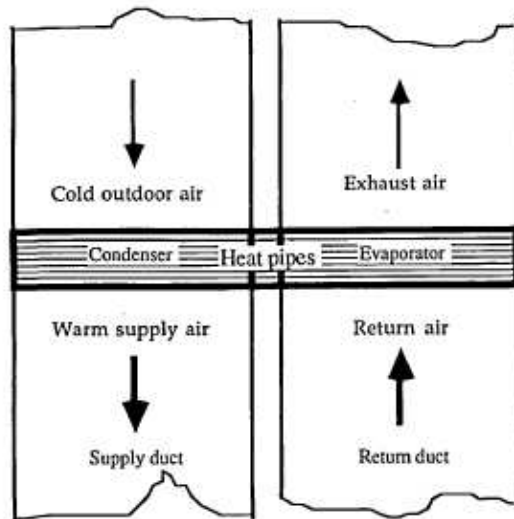

Figure 7 – Schematic representation of heat-pipe heat recovery unit in operation (45)

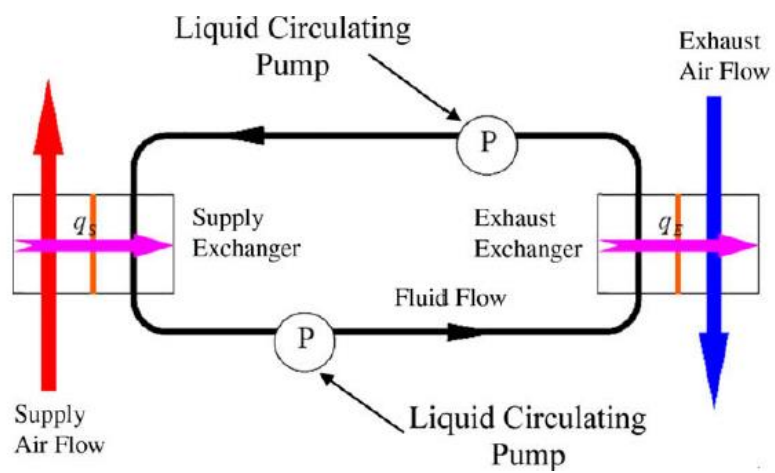

Figure 8 – Schematic diagram of a run-around heat recovery system (49)

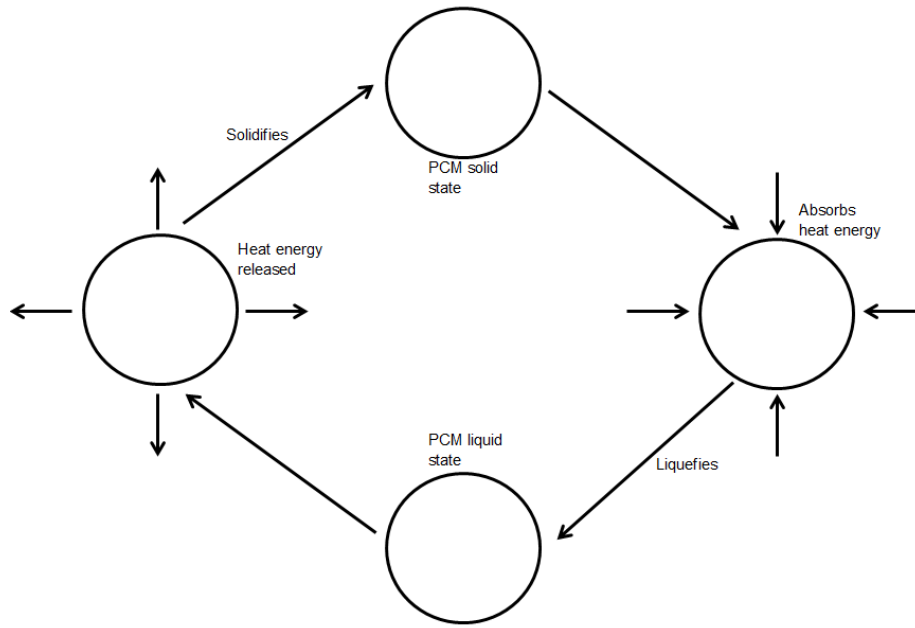

Figure 9 – Schematic diagram of heat transfer process of PCMs

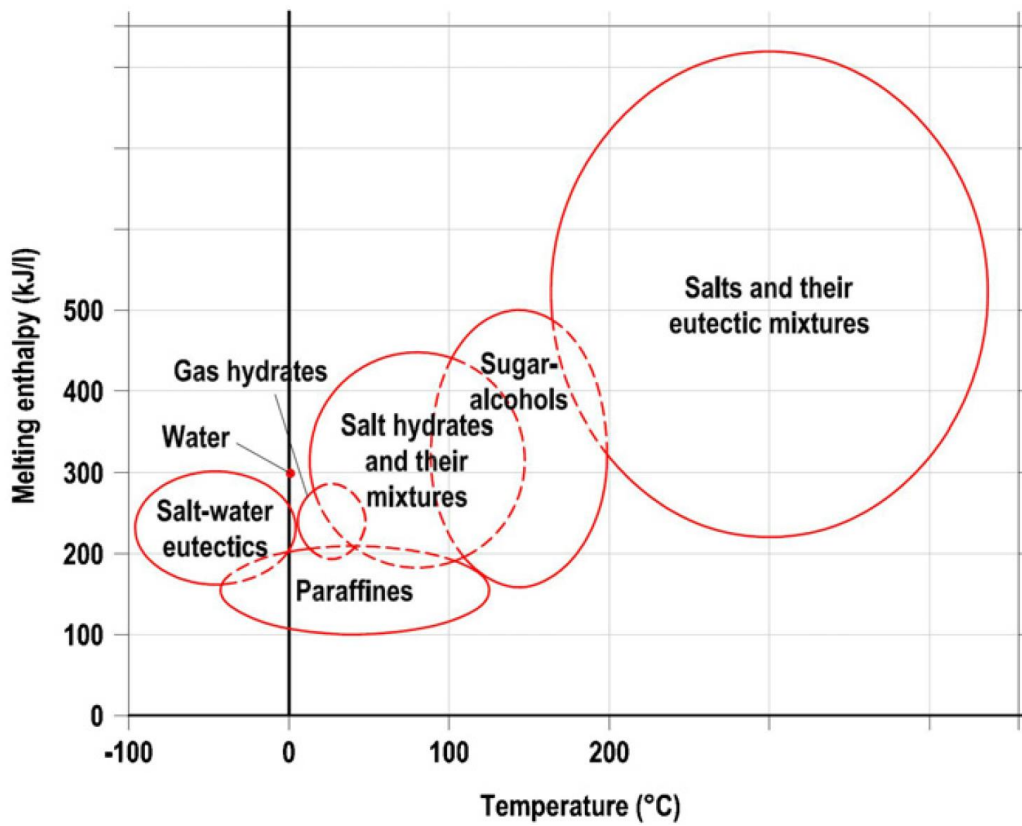

Figure 10 – The melting enthalpy and melting temperature for the different groups of phase change materials. (56)

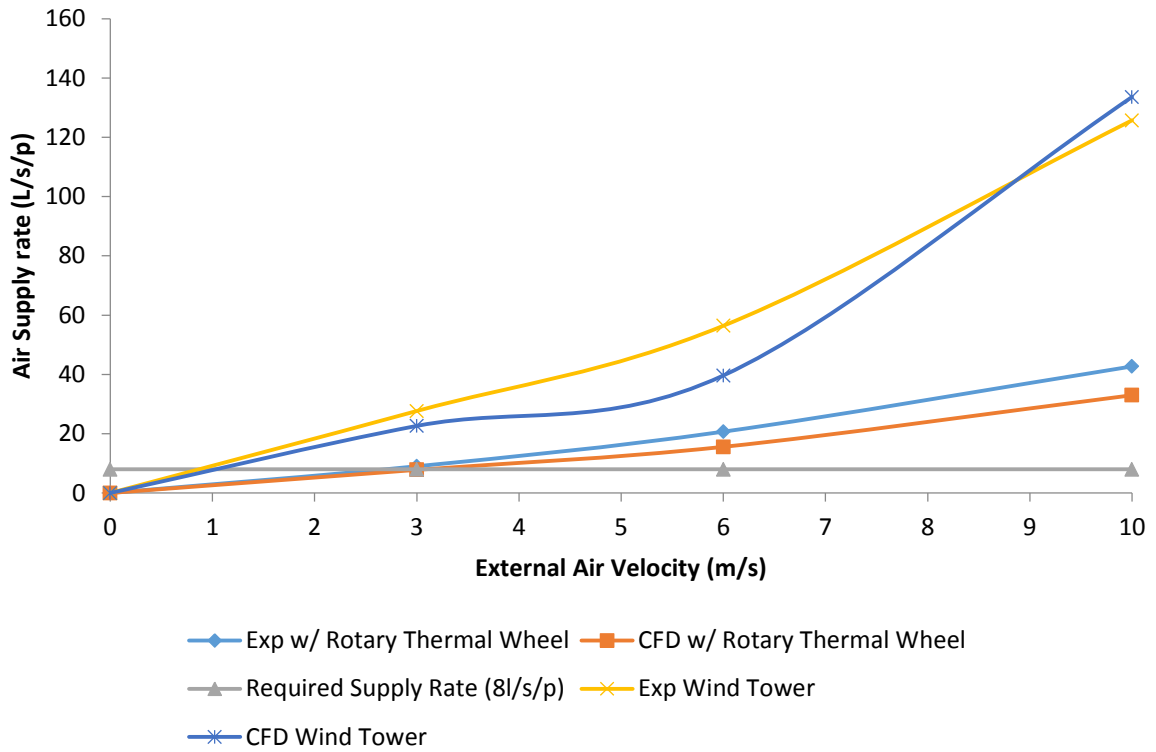

Figure 11 – Comparison of air supply rate for a wind tower and a wind tower with a rotary thermal wheel against the guideline supply rate of 8l/s.p. (61)

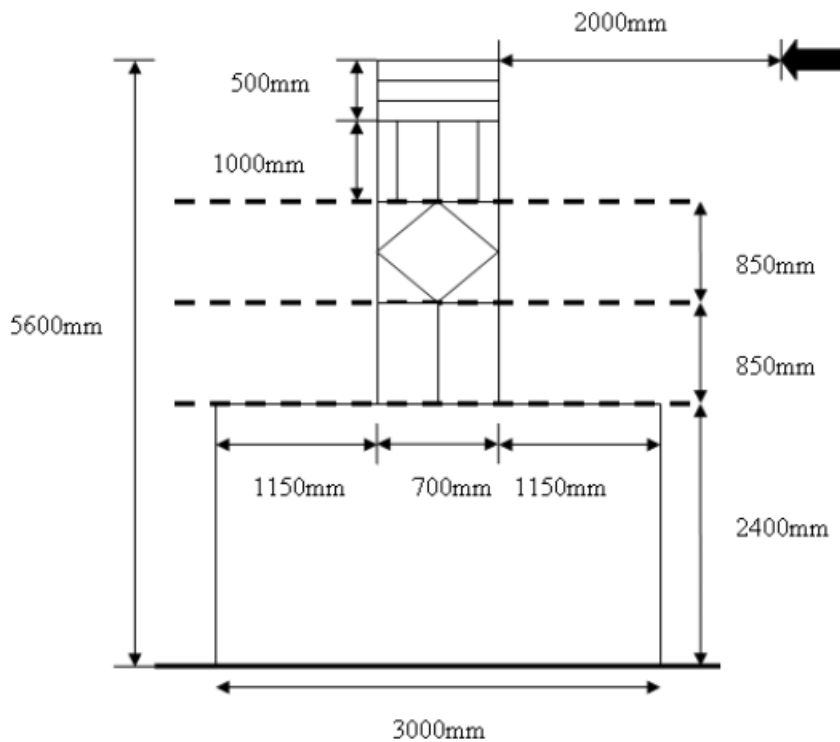

Figure 12 – The schematic diagram of experimental chamber and total dimension (62)

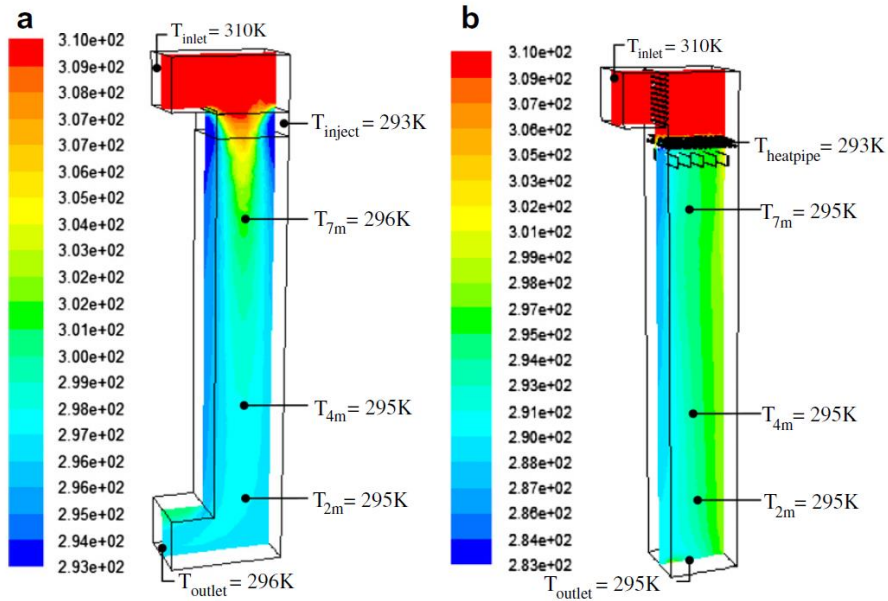

Figure 13 – Temperature contour lines of a cross sectional plane in the test channel; (a) evaporative cooling (b) heat pipe device (64)

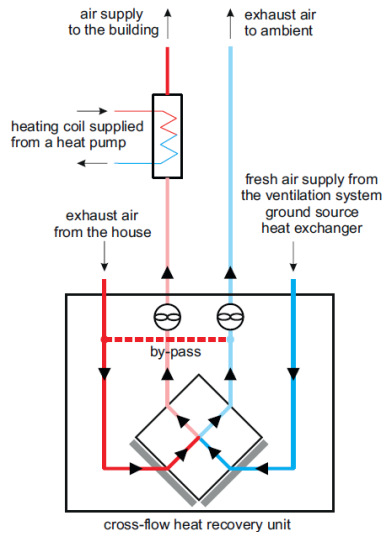

Figure 14 – The schematic view of the ventilation system in the passive house (67)

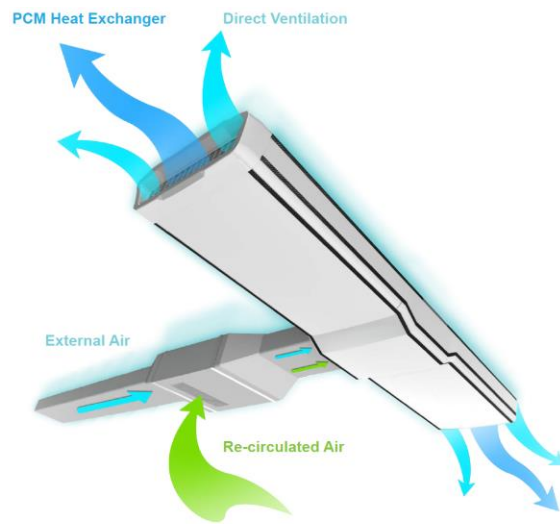

Figure 15 – Schematic diagram of operation of Cool-Phase system (71)

Table 1 – Summary and details of heat recovery devices

Type of HRV	Advantages	Disadvantages	Performance Parameters	Efficiency %	Pressure Drop (Pa)	Humidity Control	Ref
Rotary thermal wheel	High efficiency Sensible and latent heat recovery Compact design Frost control available	Cross contamination possible Requires adjacent airstreams Mechanically driven, requiring energy input	Rotation speed Air velocity Wheel Porosity	80+	4-45	Yes	(17-29)
Fixed Plate	No moving parts hence high reliability High heat transfer coefficient No cross contamination Compact design Frost control possible Sensible and latent heat recovery	High pressure loss across exchanger Limited to two separate airstreams Condensation build up Frost build up in cold climates	Material type Operating pressure Temperature Flow arrangement	70-90	7-30	Yes	(16, 17, 30-43, 62)
Heat pipes	No moving parts, high reliability No cross contamination Low pressure loss Compact design Heat recovery in two directions possible	Requires close airstreams Internal fluid should match local climate conditions	Fluid type Contact time Arrangement/configuration Structure	80	1-5	No	(7, 44-48, 63-66)
Run-around	Airstreams can be separate No cross contamination Low pressure loss Multiple sources of heat recovery	Multiple pumps required to move fluid Difficult to integrate into existing structures Low efficiency Cost	Exchanger type Fluid type Heat source	50-80	~1	No	(49-55, 67)
Phase Change Materials	Easy incorporation into building materials Offset peak energy demands No pressure loss No cross contamination No moving parts Long life cycle	Thermal storage as opposed to instantaneous transfer Expensive Not proven technology Difficulty in selecting appropriate material	Material type Impregnation method	~	0	No	(56-60, 68-71)