



Deposited via The University of Sheffield.

White Rose Research Online URL for this paper:

<https://eprints.whiterose.ac.uk/id/eprint/102867/>

Version: Accepted Version

Article:

Susmel, L. (2014) Nominal stresses and Modified Wohler Curve Method to perform the fatigue assessment of uniaxially loaded inclined welds. Proceedings of the Institution of Mechanical Engineers, Part C: Journal of Mechanical Engineering Science, 228 (16). pp. 2871-2880. ISSN: 0954-4062

<https://doi.org/10.1177/0954406214522991>

Reuse

Items deposited in White Rose Research Online are protected by copyright, with all rights reserved unless indicated otherwise. They may be downloaded and/or printed for private study, or other acts as permitted by national copyright laws. The publisher or other rights holders may allow further reproduction and re-use of the full text version. This is indicated by the licence information on the White Rose Research Online record for the item.

Takedown

If you consider content in White Rose Research Online to be in breach of UK law, please notify us by emailing eprints@whiterose.ac.uk including the URL of the record and the reason for the withdrawal request.

Nominal stresses and Modified Wöhler Curve Method to perform the fatigue assessment of uniaxially-loaded inclined welds

Luca Susmel

Department of Civil and Structural Engineering,
The University of Sheffield, Mappin Street, Sheffield, S1 3JD, UK

ABSTRACT

The present paper summarises an attempt of proposing a simple formula suitable for estimating the fatigue strength of welded connections whose weld beads are inclined with respect to the direction along which the fatigue loading is applied. By explicitly considering the degree of multiaxiality of the nominal stress state damaging the weld toe, such a formula is directly derived from the so-called Modified Wöhler Curve Method (MWCM). The MWCM is a bi-parametrical critical plane approach which postulates that, independently from the complexity of the assessed load history, fatigue strength can accurately be estimated by using the stress components relative to that material plane experiencing the maximum shear stress range. The accuracy and reliability of the proposed design technique was checked against a number of experimental results taken from the literature and generated by testing steel plates with inclined fillet welded attachments. This validation exercise allowed us to prove that the devised formula can successfully be used in situations of practical interest to design against fatigue welded joints whose welds are inclined with respect to the direction along which the cyclic force is applied.

Keywords: Welded joints, inclined welds multiaxial fatigue, proportional nominal loading, critical plane.

INTRODUCTION

The fatigue assessment of mechanical components is a complex problem that has to be addressed properly during the design process to avoid catastrophic in-service failures. In order to understand the impact of fatigue breakages on everyday life, it can be recalled here that, as reported in several well-known textbooks (see, for instance, Ref. [1] and references reported therein), 50% to 90% of mechanical assembly failures are caused by fatigue. Reviews both in the USA and Europe [2, 3] indicate that in-service breakage of components costs around 4% of GNP in industrialised nations. In this complex scenario, one of the most difficult challenges faced by those companies designing and manufacturing structural

assemblies subjected to in-service fatigue loading is improving their performances by reducing not only the weight, but also the associated production, maintenance and energy costs. It is well-known to engineers engaged in designing structures/components of any kind that one of the trickiest aspects behind a high-performance mechanical assembly is efficiently joining together its different parts. As far as metallic materials are concerned, certainly, welding represents the most adopted technological solution in situations of practical interest. For instance, if attention is focused on the automotive industry, a large number of structural parts/components are welded such as pillar reinforcements, bodyside frames, floor pans, suspension parts, steering columns, driveshafts, engine parts, transmission parts, etc. Due to the important role played by weldments in the industrial arena, since about the middle of the last century, an enormous effort has been made in order to formalise and validate (through appropriate experimental investigations) design methods suitable for performing the fatigue assessment of welded joints. As a result, nowadays structural engineers can take full advantage of several approaches which have specifically been devised to estimate fatigue damage in welded details subjected to in-service time-variable load histories [4, 5]. Amongst the existing techniques, it is recognised that the simplest method is the one making use of nominal stresses, fatigue strength being directly estimated from the specific S-N curve supplied, for the welded geometry being considered, by the available Standard Codes [4, 6, 7]. When either nominal stresses cannot be calculated or the standard fatigue curve for the specific geometry of the welded detail being assessed is not available, then either hot-spot or local stress based approaches are recommended to be used [4]. In this setting, examination of the state of the art [5, 8] shows that the most modern methodologies for the fatigue assessment of welded connections are those based on the use of local quantities. Amongst the local approaches which have been devised so far, certainly, the Fictitious Notch Radius concept [5, 9], the Theory of Critical Distances (TCD) [10-15], and the Strain Energy Density approach [16, 17] deserve to be mentioned explicitly. Owing to the fact that these design methods are based on the calculation of local stress/strain fields, in general they are used to deal with those situations which cannot directly be addressed by using the nominal stress based approach.

In this complex scenario, this paper summarises an attempt of proposing a simple nominal stress based formula suitable for estimating the fatigue strength of those welds which are inclined with respect to the direction along which the uniaxial cyclic loading is applied. The novelty characterising such an approach is that the effect of the weld orientation is directly modelled by tackling the design issue from a multiaxial fatigue viewpoint.

FUNDAMENTALS OF THE MWCM

The MWCM is a bi-parametrical critical plane approach which makes use of the shear stress range, $\Delta\tau$, and the normal stress range, $\Delta\sigma_n$, relative to the critical plane to estimate fatigue strength under multiaxial fatigue loading. According to Socie's fatigue damage model [18], the critical plane is defined as that material plane experiencing the maximum range of the shear stress. As far as welded connections are concerned, the damaging effect of stress components $\Delta\tau$ and $\Delta\sigma_n$ is suggested as being evaluated through critical plane stress ratio ρ_w , which is defined as [19]:

$$\rho_w = \frac{\Delta\sigma_n}{\Delta\tau} \quad (1)$$

According to definition (1), ρ_w is sensitive to the degree of non-proportionality of the applied loading path, but not to the presence of superimposed static stresses [8, 19]. This assumption derives from the fact that, when as-welded connections are subjected to cyclic loading, non-zero mean stresses play a minor role in the overall fatigue strength of welded connections [5]. This has to be ascribed to the effect of the local residual stresses arising from the welding process. In fact, these stresses alter, in the crack initiation regions, the local value of the load ratio, $R = \sigma_{\min}/\sigma_{\max}$, so that, under high tensile residual stresses, the local value of R can become larger than zero also under fully-reversed nominal fatigue loading. This is the reason why joints in the as-welded condition can efficiently be designed against fatigue by directly making use of reference fatigue curves experimentally determined under R ratios larger than zero. On the contrary, when welded joints are stress-relieved through appropriate heat treatments, their overall fatigue strength is seen to increase, the presence of superimposed static stresses becoming more and more important. The available codes of practice [4-6] suggest capturing the above effect by directly correcting the recommended fatigue curves through appropriate enhancement factors [9], the way of modelling the mean stress effect in stress-relieved welded joints subjected to multiaxial fatigue loading being discussed at the end of this section.

Turning back to the MWCM's *modus operandi*, our method estimates fatigue damage under complex time-variable loading according to the strategy summarised through the modified Wöhler diagram sketched in Figure 1. The above log-log chart plots the shear stress range relative to the critical plane, $\Delta\tau$, against the number of cycles to failure, N_f . By post-processing a large number of experimental results taken from the literature [19], we have shown that different modified Wöhler curves are obtained as stress ratio ρ_w varies (Fig. 1). In particular, it was observed that, given the range of the shear stress relative to the critical plane, the corresponding number of cycles to failure decreases as ρ_w increases. Alternatively,

the above trend could be described by saying that the modified Wöhler curves tend to shift downward in the diagram of Figure 1 with increasing of ρ_w .

According to the classic log-log schematisation which is adopted to summarise the fatigue strength of engineering materials and components, the position and the slope of any modified Wöhler curve can unambiguously be defined through the following linear relationships [5, 19-21]:

$$k_\tau(\rho_w) = \alpha \cdot \rho_w + \beta \quad (2)$$

$$\Delta\tau_{\text{Ref}}(\rho_w) = a \cdot \rho_w + b \quad (3)$$

In the linear laws reported above, $k_\tau(\rho_w)$ is the negative inverse slope, $\Delta\tau_{\text{Ref}}(\rho_w)$ is the reference shear stress range extrapolated at N_{Ref} cycles to failure (Fig. 1), while α , β , a and b are fatigue constants to be determined experimentally. By observing that ratio ρ_w is equal to unity under uniaxial loading (i.e., under either axial or bending fatigue loading) and to zero under cyclic torsion [5, 19], Eqs (2) and (3) can be rewritten as follows [19]:

$$k_\tau(\rho_w) = (k - k_0) \cdot \rho_w + k_0, \quad (4)$$

$$\Delta\tau_{\text{Ref}}(\rho_w) = \left(\frac{\Delta\sigma_A}{2} - \Delta\tau_A \right) \cdot \rho_w + \Delta\tau_A \quad (5)$$

In the above relationships k and k_0 are the negative inverse slopes of the uniaxial and torsional fatigue curve, respectively, whereas $\Delta\sigma_A$ and $\Delta\tau_A$ are the ranges of the corresponding reference stresses extrapolated at N_{Ref} cycles to failure. Since the only fatigue curves which are usually available to calibrate the MWCM are the uniaxial and the torsional ones, Eqs (4) and (5) suggest that, given the value of ρ_w , the position of the corresponding modified Wöhler curve has to be estimated.

The way of using the MWCM to predict fatigue lifetime of welded joints subjected to multiaxial fatigue loading is summarised in Figure 2. Consider then the tube-to-plate welded joint loaded in combined tension and torsion which is sketched in Figure 2a. Given the geometry and the absolute dimensions of the connection being assessed, the appropriate uniaxial and torsional standard fatigue curves (selected amongst those stated by the pertinent Standard Codes) can be used to directly calibrate Eqs (4) and (5). Subsequently, by post-processing the time-variable nominal stress state damaging the connection being designed (Fig. 2b), the orientation of the critical plane and the corresponding stress

quantities of interest (i.e., $\Delta\tau$ and $\Delta\sigma_n$ in Figure 2c) have to be determined by taking full advantage of one of the existing stress analysis tools [22, 23]. As soon as both $\Delta\tau$ and $\Delta\sigma_n$ are known, the corresponding critical plane stress ratio, ρ_w , can directly be calculated according to definition (1) - Figure 2c. The obtained value for ρ_w allows the position of the pertinent modified Wöhler to be estimated through calibration functions (4) and (5) – see Figures 2d and 2e. Finally, the number of cycles to failure, N_f , can directly be predicted by using the following trivial relationship (Fig. 2e):

$$N_f = N_{Ref} \cdot \left[\frac{\Delta\tau_{ref}(\rho_w)}{\Delta\tau} \right]^{k_t(\rho_w)} \quad (6)$$

If the uniaxial and torsional fatigue curves stated by the pertinent Standard Codes are employed as supplied to calibrate relationships (4) and (5), then the use of the MWCM results in accurate estimate as long as the welded joints being designed are supposed to work in the as-welded condition. On the contrary, if the welded connections under investigation are stress relieved, the accuracy in estimating fatigue lifetime can be increased by multiplying the reference shear stress range of the adopted modified Wöhler curve, $\Delta\tau_{Ref}$, by a suitable enhancement factor, $f(R_{CP})$, i.e.:

$$\Delta\tau_{Ref}(\rho_w) \cdot f(R_{CP}) = \left[\left(\frac{\Delta\sigma_A}{2} - \Delta\tau_A \right) \cdot \rho_w + \Delta\tau_A \right] \cdot f(R_{CP}) \quad (7)$$

To derive Eq. (7), the assumption was made that factor $f(R_{CP})$ depends on the load ratio, R_{CP} , calculated by using solely the stress perpendicular to the critical plane, that is [24]:

$$R_{CP} = \frac{\sigma_{n,min}}{\sigma_{n,max}} \quad (8)$$

where $\sigma_{n,min}$ and $\sigma_{n,max}$ are the minimum and the maximum value of the stress perpendicular to the critical plane, respectively. The idea of using the stress perpendicular to the critical plane to estimate, in stress relieved welded joints, the damaging effect of non-zero mean stresses takes as its starting point the fact that in non-welded metallic materials the presence of non-zero mean shear stresses can be neglected with little loss of accuracy as long as the maximum shear stress (during the loading cycle) is lower than the material yield shear stress [25]. According the above hypothesis (which is fully supported by the experimental evidence), the rules recommended by Sonsino in Ref. [9] to estimate the fatigue

enchantment factors under uniaxial fatigue loading can directly be extended to multiaxial fatigue situations as follows: [24]:

$$\begin{aligned}
 f(R_{CP}) &= 1.32 && \text{for } R_{CP} < -1 \\
 f(R_{CP}) &= -0.22 \times R_{CP} + 1.1 && \text{for } -1 \leq R_{CP} \leq 0 \\
 f(R_{CP}) &= -0.2 \times R_{CP} + 1.1 && \text{for } 0 < R_{CP} \leq 0.5 \\
 f(R_{CP}) &= 1 && \text{for } R_{CP} > 0.5
 \end{aligned} \tag{9}$$

for steel welded joints and

$$\begin{aligned}
 f(R_{CP}) &= 1.88 && \text{for } R_{CP} < -1 \\
 f(R_{CP}) &= -0.55 \times R_{CP} + 1.33 && \text{for } -1 \leq R_{CP} \leq 0 \\
 f(R_{CP}) &= -0.66 \times R_{CP} + 1.33 && \text{for } 0 < R_{CP} \leq 0.5 \\
 f(R_{CP}) &= 1 && \text{for } R_{CP} > 0.5
 \end{aligned} \tag{10}$$

for aluminium welded joints.

MWCM AND UNIAXIALLY-LOADED INCLINED WELDS

As far as fillet welds are concerned, the available Standard Codes and Recommendations [4, 6, 7] state different design fatigue curves which can be used to design connections subjected to uniaxial cyclic forces which are applied either normal or parallel to the weld axis. Some practical rules are suggested as being used to address those situations in which the weld bead is inclined with respect to the applied cyclic force [4]. Even if these rules are daily used by engineers engaged in designing welded structures and components, there are indications that these simple approaches should be improved in order to better take into account the actual direction of loading [26].

By taking as a starting point the assumption that inclined welds are subjected to proportional multiaxial local stress states even though the externally applied force is uniaxial, in what follows the MWCM applied in terms of nominal stresses is attempted to be used to derive a simple formula which can be used to accurately address this specific design problem. As to the idea of tackling this issue from a multiaxial fatigue viewpoint, it can be recalled here that the local physical processes resulting in the initiation of fatigue cracks depend on the entire stress field acting on the material in the vicinity of the crack initiation locations [8]. This implies that, as far as stress concentration phenomena of any kind are concerned, fatigue strength should always be estimated by adopting appropriate multiaxial fatigue criteria, since the stress fields acting on the fatigue process zone are always, at least, biaxial (this holding true independently from the degree of multiaxiality of the nominal load history). As

a result, notched components can be damaged either by external or by inherent multiaxiality: in the latter case the degree of multiaxiality of the local stress field depends on the geometrical feature contained by the component being assessed, whereas in the first case on the complexity of the applied loading path [27].

Bearing in mind the above remarks, consider the inclined fillet welded attachment sketched in Figure 3. This connection is assumed to be subjected to a uniaxial cyclic force, the corresponding nominal stress range, calculated with respect to the cross-sectional area of the plate, being equal to $\Delta\sigma_{nom}$. In order to tackle the design problem from a multiaxial fatigue point of view, the nominal stress range can be decomposed into two stress components so that $\Delta\sigma_x$ and $\Delta\tau_{xy}$ are perpendicular and parallel to the weld bead, respectively (Fig. 3). If θ is the angle defining the orientation of the weld with respect to the direction perpendicular to the applied loading (Fig. 3), the nominal stress components of interest can directly be calculated as follows [26]:

$$\Delta\sigma_x = \Delta\sigma_{nom} \cdot \cos^2 \theta \quad (11)$$

$$\Delta\tau_{xy} = \Delta\sigma_{nom} \cdot \sin \theta \cdot \cos \theta \quad (12)$$

The use of the above stress quantities to perform the fatigue assessment of welded joints can fully be justified by advocating the Notch-Stress Intensity Factor (N-SIF) approach [28]. Such a Linear Elastic Fracture Mechanics based method postulates that the fatigue damage extent in sharply notched engineering materials depends on the singular stress components [29]. In the presence of notch opening angles larger than about 100° , Mode II stresses are no longer singular [30], so that, fatigue damage can accurately be estimated by solely considering the contributions due to Mode I and Mode III loading [29]. Accordingly, fatigue strength of welded joints is suggested as being estimated by employing quantities which are directly related to the stress components due to Mode I and Mode III loading, respectively [31]. In this setting, to correctly use nominal quantities to estimate multiaxial fatigue damage in welded details, the total nominal stress tensor has to be decomposed into stress components $\Delta\sigma_x$ and $\Delta\tau_{xy}$ that are directly related to the local stresses due to Mode I and Mode III loading, respectively [31]. According to the above schematisation, the nominal stress tensor associated with the inclined weld being assessed can then be expressed as follows:

$$[\Delta\sigma] = \begin{bmatrix} \Delta\sigma_x & \Delta\tau_{xy} & 0 \\ \Delta\tau_{xy} & 0 & 0 \\ 0 & 0 & 0 \end{bmatrix} \quad (13)$$

The corresponding Mohr circle sketched in terms of ranges in Figure 4 allows the stresses relative to the critical plane to directly be calculated through the following trivial relationships:

$$\Delta\sigma_n = \frac{\Delta\sigma_x}{2} = \frac{\Delta\sigma_{nom}}{2} \cdot \cos^2 \theta \quad (14)$$

$$\Delta\tau = \sqrt{\frac{\Delta\sigma_x^2}{4} + \Delta\tau_{xy}^2} = \frac{\Delta\sigma_{nom} \cdot \cos^2 \theta}{2} \sqrt{1 + 4 \tan^2 \theta} \quad \text{for } \theta \neq \frac{\pi}{2} \quad (15)$$

By defining now trigonometric quantity q as:

$$q = \frac{1}{\sqrt{1 + 4 \tan^2 \theta}}, \quad (16)$$

it is straightforward to calculate the ρ_w value associated with the assessed inclination angle, θ , as follows:

$$\rho_w = \frac{\Delta\sigma_n}{\Delta\tau} = \frac{1}{\sqrt{1 + 4 \tan^2 \theta}} = q \quad (17)$$

This implies that calibration functions (4) and (5) can be rewritten for the specific case of a uniaxially-loaded inclined weld by simply replacing ρ_w with q , i.e.:

$$k_\tau(\rho_w) = k_\tau(q) = (k - k_0) \cdot q + k_0, \quad (18)$$

$$\Delta\tau_{Ref}(\rho_w) = \Delta\tau_{Ref}(q) = \left(\frac{\Delta\sigma_A}{2} - \Delta\tau_A \right) \cdot q + \Delta\tau_A \quad (19)$$

Finally, by taking full advantage of Eqs (15) to (19), the number of cycles to failure, N_f , can directly be predicted through relationship (6) rewritten as:

$$N_f = N_{Ref} \cdot \left[q \frac{\Delta\sigma_A + 2\Delta\tau_A(1-q)}{\Delta\sigma_{nom} \cos^2 \theta} f(R_{CP}) \right]^{(k-k_0)q+k_0} \quad (19)$$

where $f(R_{CP})$ is the fatigue enhancement factor estimated according to empirical formulas (9) and (10). To conclude, it is worth observing that, if the load history applied to the welded component being designed is characterised by a nominal load ratio equal to $R = \sigma_{nom,min} / \sigma_{nom,max}$, load ratio R_{CP} calculated according to definition (8) is invariably equal to R , in fact:

$$R_{CP} = \frac{\sigma_{n,min}}{\sigma_{n,max}} = \frac{\sigma_{nom,min} \cdot \cos^2 \theta / 2}{\sigma_{nom,max} \cdot \cos^2 \theta / 2} = \frac{\sigma_{nom,min}}{\sigma_{nom,max}} = R \quad (20)$$

VALIDATION BY EXPERIMENTAL DATA

To check the accuracy and reliability of the proposed design formula, a number of experimental results generated by testing, under zero-tension ($R=0$) uniaxial fatigue loading, steel plates with inclined fillet welds were selected from the technical literature. The geometries of the welded samples tested by Booth and Maddox [32] are sketched in Figure 5, whereas those tested by Kim and Yamada [33] in Figure 6. In both experimental investigations weld ends were mechanically treated to force fatigue cracks to initiate in the middle of the attachments. Accordingly, the portions of the weld beads of interest were tested in the as-welded condition, resulting in a fatigue enhancement factor, $f(R_{CP})$, invariably equal to unity [9].

As recommended by the IIW [4], fatigue lifetime of plates with transverse fillet welded attachments (i.e., the $\theta=0^\circ$ case) can accurately be estimated by using the FAT 71 design curve, that is, a Wöhler curve having, for a probability of survival, P_s , equal to 97.7%, reference stress range, $\Delta\sigma_A$, at $N_{Ref}=2 \cdot 10^6$ cycles to failure equal to 71 MPa and negative inverse slope, k , equal to 3. The $\Delta\sigma_{nom}$ vs. N_f diagram sketched in Figure 7 confirms that the above design curve is capable of correctly describing the fatigue behaviour of the investigated transverse fillet welds. As to the scatter band plotted in this chart, it is important to point out here that it was derived from the reference value of 1.5 recommended by Haibach and estimated by post-processing scatter bands delimited by experimental fatigue curves recalculated for a probability of survival equal to 10% and 90%, respectively [34]. In accordance with the above reference value, the scatter ratio of the stress range at $2 \cdot 10^6$ cycles to failure for 2.3% and 97.7% probabilities of survival was then taken equal to 1.85.

In order to correctly apply the MWCM, the constants in calibration functions (18) and (19) must be determined by considering also a fatigue curve experimentally determined under

torsional fatigue loading. As far as fillet welds subjected to cyclic shear stress are concerned, the IIW [4] recommends performing the fatigue assessment by using a Wöhler curve having reference shear stress range, $\Delta\tau_A$, at $N_{Ref}=2\cdot 10^6$ cycles to failure equal to 80 MPa (for $P_S=97.7\%$) and negative inverse slope, k_0 , equal to 5 (FAT 80 torsional fatigue curve).

The modified Wöhler diagrams sketched in Figure 8 fully confirm that the MWCM is capable of correctly modelling the fatigue behaviour of uniaxially-loaded fillet welds as the inclination angle, θ , increases from 0° to 45° . In particular, it is worth observing that such a remarkable accuracy is obtained by simply estimating the position of the pertinent modified Wöhler curve from Eqs (18) and (19) calibrated through the FAT 71 uniaxial and FAT 80 torsional fatigue curve [4]. As to the reported scatter bands, they were determined by imposing, as suggested by Haibach [34], a ratio of the stress range at $2\cdot 10^6$ cycles to failure for $P_S=2.3\%$ and $P_S=97.7\%$ equal to 1.85.

To conclude, the experimental, N_f , vs. estimated, $N_{f,e}$, number of cycles to failure diagram reported in Figure 9 summarises the accuracy of design formula (19) in estimating the fatigue lifetime of the investigated welded joints, the FAT 71 uniaxial and FAT 80 torsional fatigue curve recalculated for $P_S=50\%$ being used as calibration information. The error diagram of Figure 9 makes it evident that design formula (19) is highly accurate in estimating fatigue lifetime of inclined fillet welds, resulting in predictions falling within Haibach's normalised uniaxial scatter band.

CONCLUSIONS

- 1) Uniaxially-loaded inclined fillet welds can accurately be designed against fatigue by addressing the problem from a multiaxial fatigue viewpoint.
- 2) When the inclination angle is larger than zero and the problem is addressed in terms of nominal stresses, fillet welds can be assumed to be damaged by biaxial stress states that vary proportionally.
- 3) The new formula proposed in the present paper and directly derived from the MWCM was seen to be highly accurate in estimating fatigue lifetime of uniaxially-loaded inclined fillet welds.
- 4) More work needs to be done in this area to check the accuracy of the MWCM in estimating fatigue strength of inclined welds when our multiaxial fatigue criterion is applied in terms of either hot-spot or local stresses.

REFERENCES

- [1] Stephens RI, Fatemi A, Stephens RR, Fuchs HO. *Metal Fatigue in Engineering*. 2nd Edition, Wiley, New York, USA, 2000.

- [2] Reed RP, Smith JH, Christ BW. *The Economic Effects of Fracture in the United States*. U.S. Department of Commerce, National Bureau of Standards, Special Publication 647, March 1983.
- [3] Faria L. *The economic effect of fracture in Europe*. Final report of European Atomic Energy Community - Study contract no. 320105, 1991.
- [4] Hobbacher A. *Recommendations for fatigue design of welded joints and components*. International Institute of Welding, Document XIII-2151-07/XV-1254-07, May 2007.
- [5] Radaj D, Sonsino CM, Fricke W. *Fatigue Assessment of Welded Joints by Local Approaches*. Woodhead, Cambridge, UK, 2007.
- [6] Anon. (1988) *Design of steel structures*. ENV 1993-1-1, EUROCODE 3.
- [7] Anon. (1999) *Design of aluminium structures – Part 2: Structures susceptible to fatigue*. ENV 1999, EUROCODE 9.
- [8] Susmel L. *Multiaxial Notch Fatigue: from nominal to local stress-strain quantities*. Woodhead & CRC, Cambridge, UK, ISBN: 1 84569 582 8, March 2009.
- [9] Sonsino CM. A consideration of allowable equivalent stresses for fatigue design of welded joints according to the notch stress concept with the reference radii $r_{ref}=1.00$ and 0.05 mm. *Welding in the World*, 2009; 53 3/4: pp. R64-R75.
- [10] Taylor D, Barrett N, Lucano G. Some new methods for predicting fatigue in welded joints. *Int J Fatigue* 2002; 24: 509-518.
- [11] Susmel L. Modified Wöhler Curve Method, Theory of Critical Distances and EUROCODE 3: a novel engineering procedure to predict the lifetime of steel welded joints subjected to both uniaxial and multiaxial fatigue loading. *Int J Fatigue* 2008; 30: 888-907.
- [13] Susmel L. The Modified Wöhler Curve Method calibrated by using standard fatigue curves and applied in conjunction with the Theory of Critical Distances to estimate fatigue lifetime of aluminium weldments. *Int J Fatigue* 2009; 31: 197-212.
- [14] Susmel L. Estimating fatigue lifetime of steel weldments locally damaged by variable amplitude multiaxial stress fields. *Int J Fatigue* 2010; 32: 1057–1080.
- [15] Susmel L, Askes H. Modified Wöhler Curve Method and multiaxial fatigue assessment of thin welded joints. *Int J Fatigue* 2012;43: 30–42.
- [16] Lazzarin P, Zambardi R. A finite-volume-energy based approach to predict the static and fatigue behaviour of components with sharp V-shaped notches. *Int J Fracture* 2001; 112: 275-298.
- [17] Livieri P, Lazzarin P. Fatigue Strength of steel and aluminium welded joints based on generalised stress intensity factors and local strain energy. *Int J Fracture* 2005; 133: 247-276.
- [18] Socie DF. Multiaxial fatigue damage models. *J Eng Mater Tech (Trans ASME)* 1987; 109: 293–298.
- [19] Susmel L, Tovo R. On the use of nominal stresses to predict the fatigue strength of welded joints under biaxial cyclic loadings. *Fatigue Fract Engng Mater Struct* 2004; 27:1005-1024.
- [20] Susmel L, Lazzarin P. A Bi-Parametric Modified Wöhler Curve for High Cycle Multiaxial Fatigue Assessment. *Fatigue Fract Engng Mater Struct* 2002; 25: 63-78.
- [21] Lazzarin P, Susmel L. A Stress-Based Method to Predict Lifetime under Multiaxial Fatigue Loadings. *Fatigue Fract Engng Mater Struct* 2003; 26: 1171-1187.
- [22] Susmel L. A simple and efficient numerical algorithm to determine the orientation of the critical plane in multiaxial fatigue problems. *Int J Fatigue* 2010; 32: 1875–1883.

- [23] Susmel L, Tovo R, Socie DF. Estimating the orientation of Stage I crack paths through the direction of maximum variance of the resolved shear stress. *Int J Fatigue* 2014; 58; 94-101.
- [24] Susmel L, Sonsino CM, Tovo R. Accuracy of the Modified Wöhler Curve Method applied along with the $r_{ref}=1$ mm concept in estimating lifetime of welded joints subjected to multiaxial fatigue loading. *Int J Fatigue* 2011; 33; 1075-1091.
- [25] Sines G. Behaviour of metals under complex static and alternating stresses. In: *Metal Fatigue*, edited by G. Sines and J. L. Waisman. McGraw-Hill, New York, pp. 145-169, 1959.
- [26] Maddox SJ. *Fatigue assessment of welds not oriented either normal or parallel to the direction of loading*. IIW Document JWG XIII/XV-218-10, 2010.
- [27] Susmel L, Atzori B, Meneghetti G, Taylor D. Notch and Mean Stress Effect in Fatigue as Phenomena of Elasto-Plastic Inherent Multiaxiality. *Eng Fract Mech* 78: 2011; 1628-1643.
- [28] Lazzarin P, Tovo R. A notch stress intensity factor approach to the stress analysis of welds. *Fatigue Fract Engng Mater Struct* 1998; 21; 1089-1104.
- [29] Lazzarin P, Sonsino CM, Zambardi R. A notch stress intensity approach to assess the multiaxial fatigue strength of welded tube-to-flange joints subjected to combined loadings. *Fatigue Fract Engng Mater Struct* 2004; 27; 127-140.
- [30] Lazzarin P, Tovo R. A unified approach to the evaluation of linear elastic stress fields in the neighbourhood of cracks and notches. *Int J Fracture* 1996; 78; 3-19.
- [31] Susmel L, Tovo R. Local and structural multiaxial stress states in welded joints under fatigue loading. *Int J Fatigue*, 2006; 28; 564-575.
- [32] Booth GS, Maddox SJ. *Influence of various factors on the fatigue strength of steel plates with fillet-welded attachments*. TWI Research Report no. 93, 1979.
- [33] Kim I-T, Yamada K. *Fatigue behaviour of fillet welded joints inclined to a uniaxial cyclic load*. IIW Document XIII-2021-04, 2004.
- [34] Haibach E. *Service fatigue-strength – methods and data for structural analysis*. Düsseldorf: VDI; 1992.

NOMENCLATURE

| | |
|--------------------------|---|
| a, b, α , β | Constants in the MWCM's calibration functions |
| f(R_{CP}) | Enhancement factor |
| k | Negative inverse of the uniaxial fatigue curve |
| k_0 | Negative inverse of the torsional fatigue curve |
| k_τ | Negative inverse of the modified Wöhler curve |
| N_f | Number of cycles to failure |
| N_{Ref} | Reference number of cycles to failure |
| R | Load Ratio |
| R_{CP} | Load Ratio ($R_{CP}=\sigma_{n,min}/\sigma_{n,max}$) |
| θ | Weld bead inclination angle |
| ρ_w | Critical plane stress ratio for welded joints |
| $\sigma_{n,min}$ | Minimum stress perpendicular to the critical plane |
| $\sigma_{n,max}$ | Maximum stress perpendicular to the critical plane |

| | |
|----------------------|--|
| $\Delta\sigma_A$ | Uniaxial reference stress range extrapolated at N_{Ref} cycles to failure |
| $\Delta\sigma_n$ | Range of the stress normal to the critical plane |
| $\Delta\sigma_{nom}$ | Range of the nominal stress |
| $\Delta\sigma_x$ | Range of the stress normal to the weld bead |
| $\Delta\tau$ | Range of the shear stress relative to the critical plane |
| $\Delta\tau_A$ | Torsional reference stress range extrapolated at N_{Ref} cycles to failure |
| $\Delta\tau_{Ref}$ | Reference shear stress range extrapolated at N_{Ref} cycles to failure |
| $\Delta\tau_{xy}$ | Range of the shear stress parallel to the weld bead |

List of Captions

Figure 1: Modified Wöhler diagram.

Figure 2: In-field usage of the MWCM.

Figure 3: Inclined fillet weld subjected to uniaxial nominal fatigue loading and definition of nominal stresses $\Delta\sigma_x$ and $\Delta\tau_{xy}$.

Figure 4: Stress components relative to the critical plane calculated through Mohr's circle.

Figure 5: Geometry of the welded specimens tested by Booth and Maddox [32] (Dimensions in millimetres).

Figure 6: Geometries of the welded specimens tested by Kim and Yamada [33] (Dimensions in millimetres).

Figure 7: Accuracy of the FAT 71 fatigue curve in estimating the fatigue strength of the transverse fillet welds tested by Booth and Maddox (BM) [32] and by Kim and Yamada (KY) [33].

Figure 8: Accuracy of the MWCM in modelling the fatigue strength of the fillet welds tested by Booth and Maddox (BM) [32] and by Kim and Yamada (KY) [33].

Figure 9: Accuracy of the MWCM in estimating the fatigue lifetime of the fillet welds tested by Booth and Maddox (BM) [32] and by Kim and Yamada (KY) [33] – Lifetime is estimated by calibrating the MWCM through design fatigue curves recalculated for $P_S=50\%$.

Figures

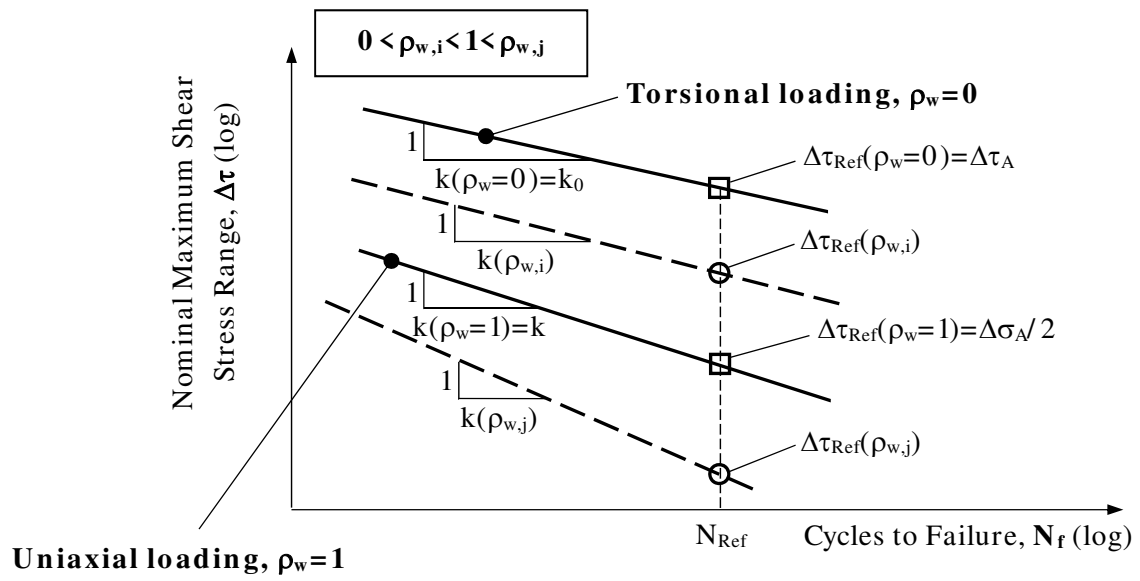

Figure 1: Modified Wöhler diagram.

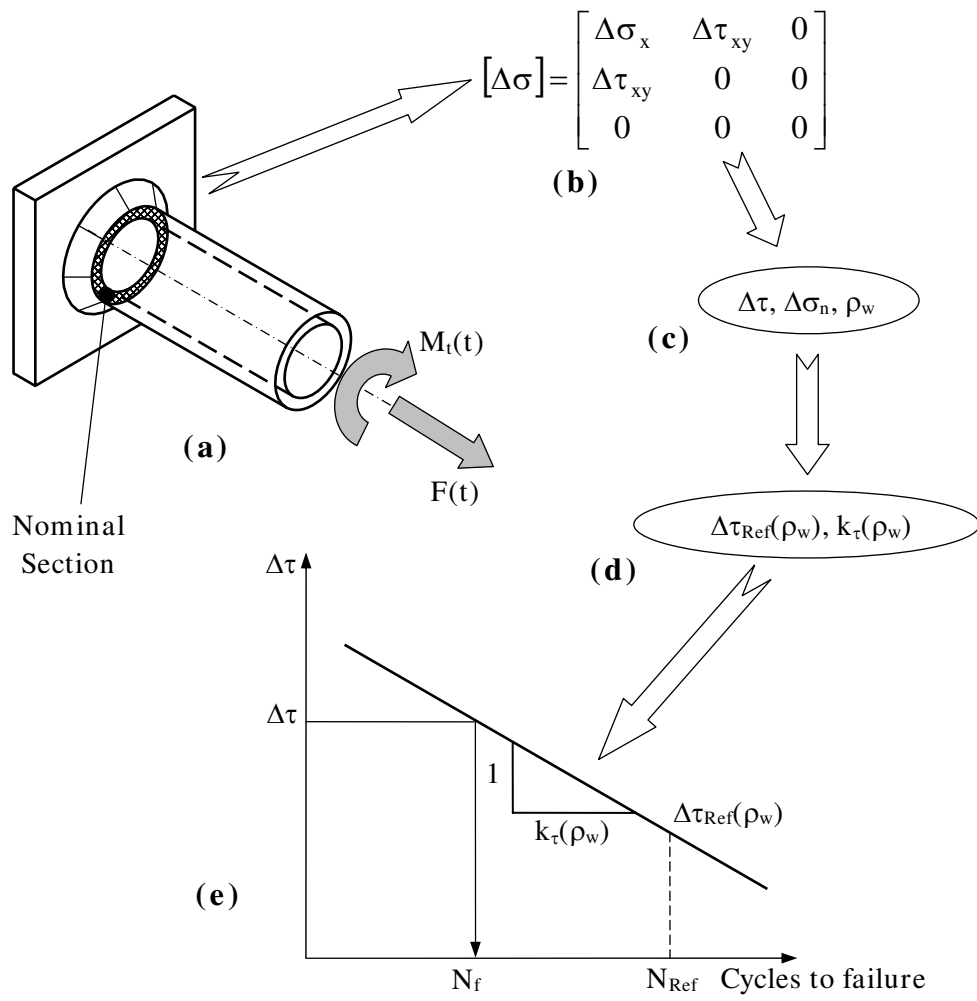

Figure 2: In-field usage of the MWCM.

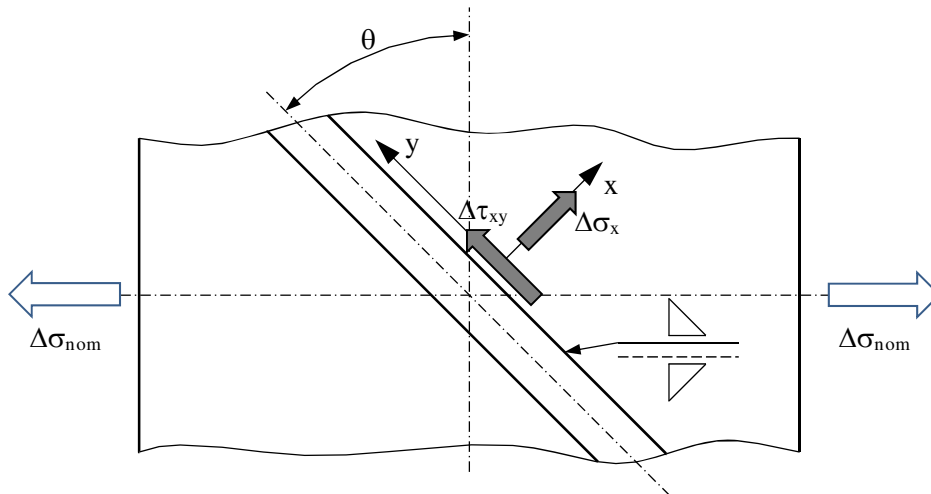

Figure 3: Inclined fillet weld subjected to uniaxial nominal fatigue loading and definition of nominal stresses $\Delta\sigma_x$ and $\Delta\tau_{xy}$.

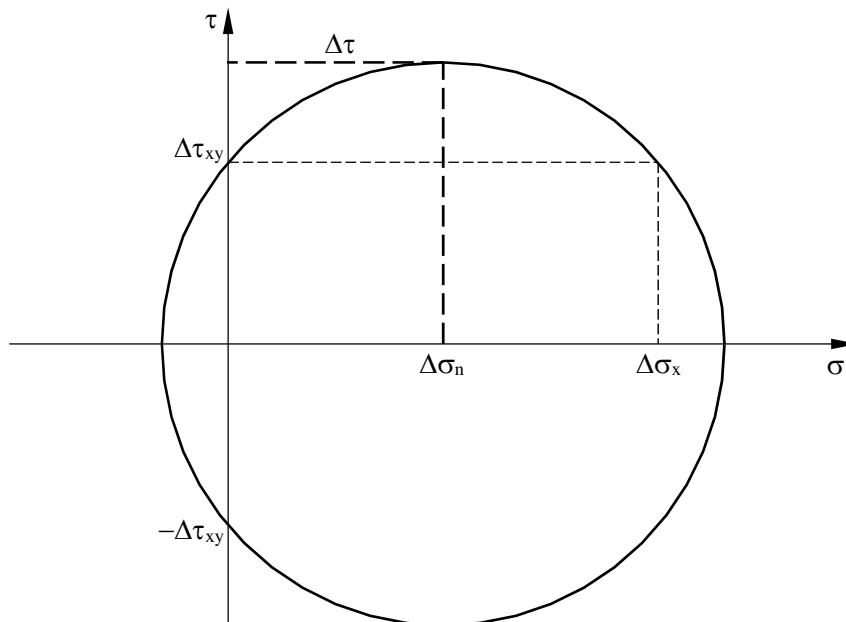

Figure 4: Stress components relative to the critical plane calculated through Mohr's circle.

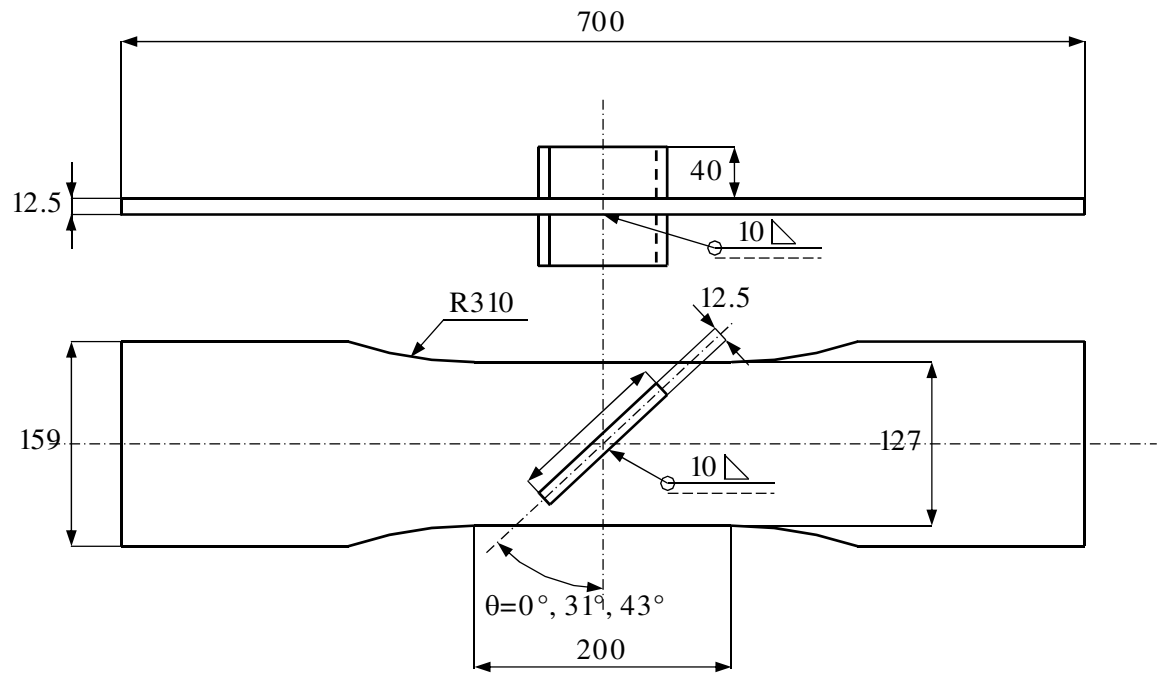
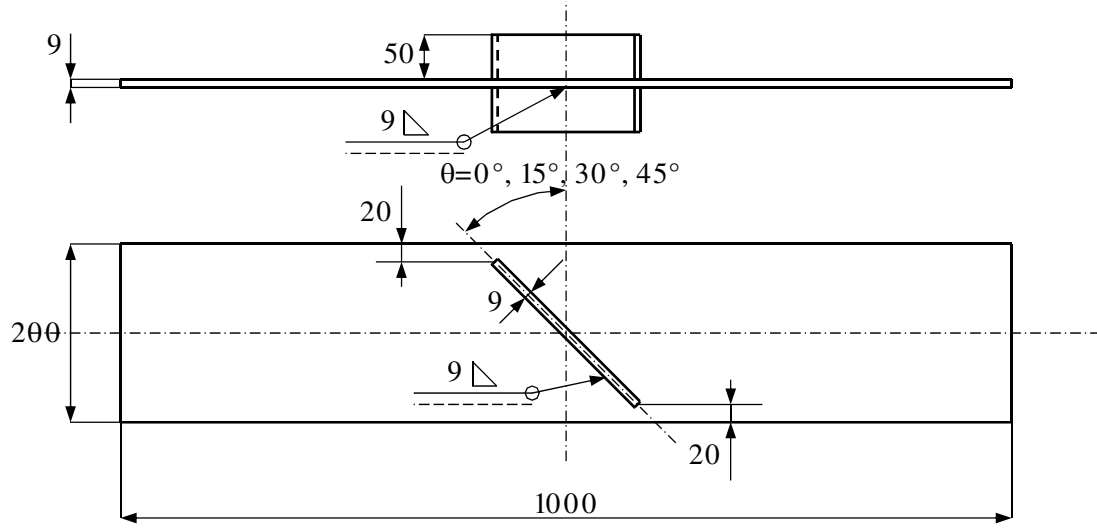
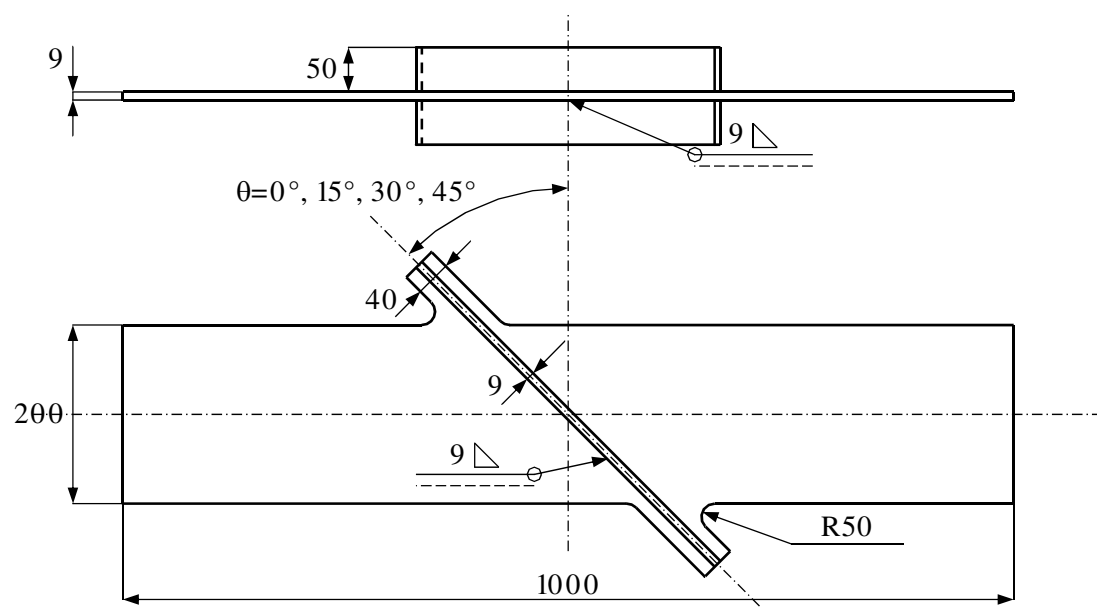

Figure 5: Geometry of the welded specimens tested by Booth and Maddox [32] (Dimensions in millimetres).



Out-of-plane gusset specimen



Non-load-carrying cruciform specimen

Figure 6: Geometries of the welded specimens tested by Kim and Yamada [33] (Dimensions in millimetres).

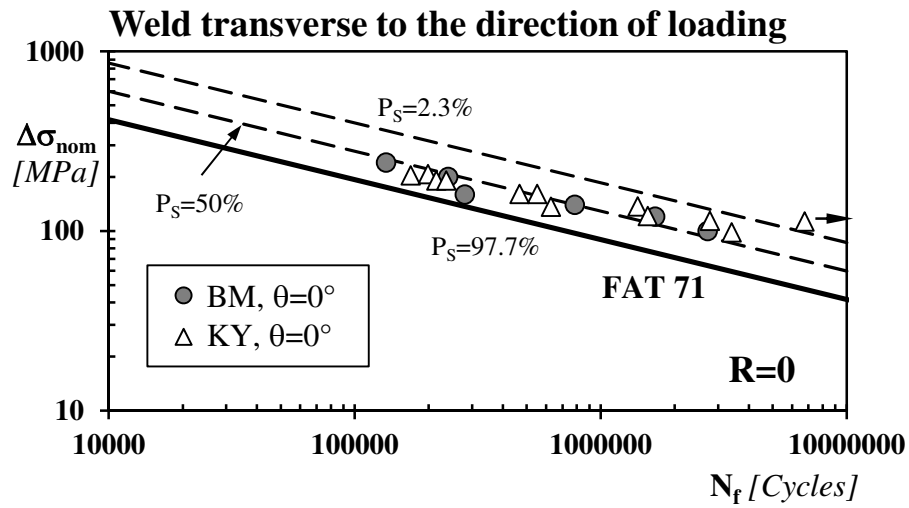

Figure 7: Accuracy of the FAT 71 fatigue curve in estimating the fatigue strength of the transverse fillet welds tested by Booth and Maddox (BM) [32] and by Kim and Yamada (KY) [33].

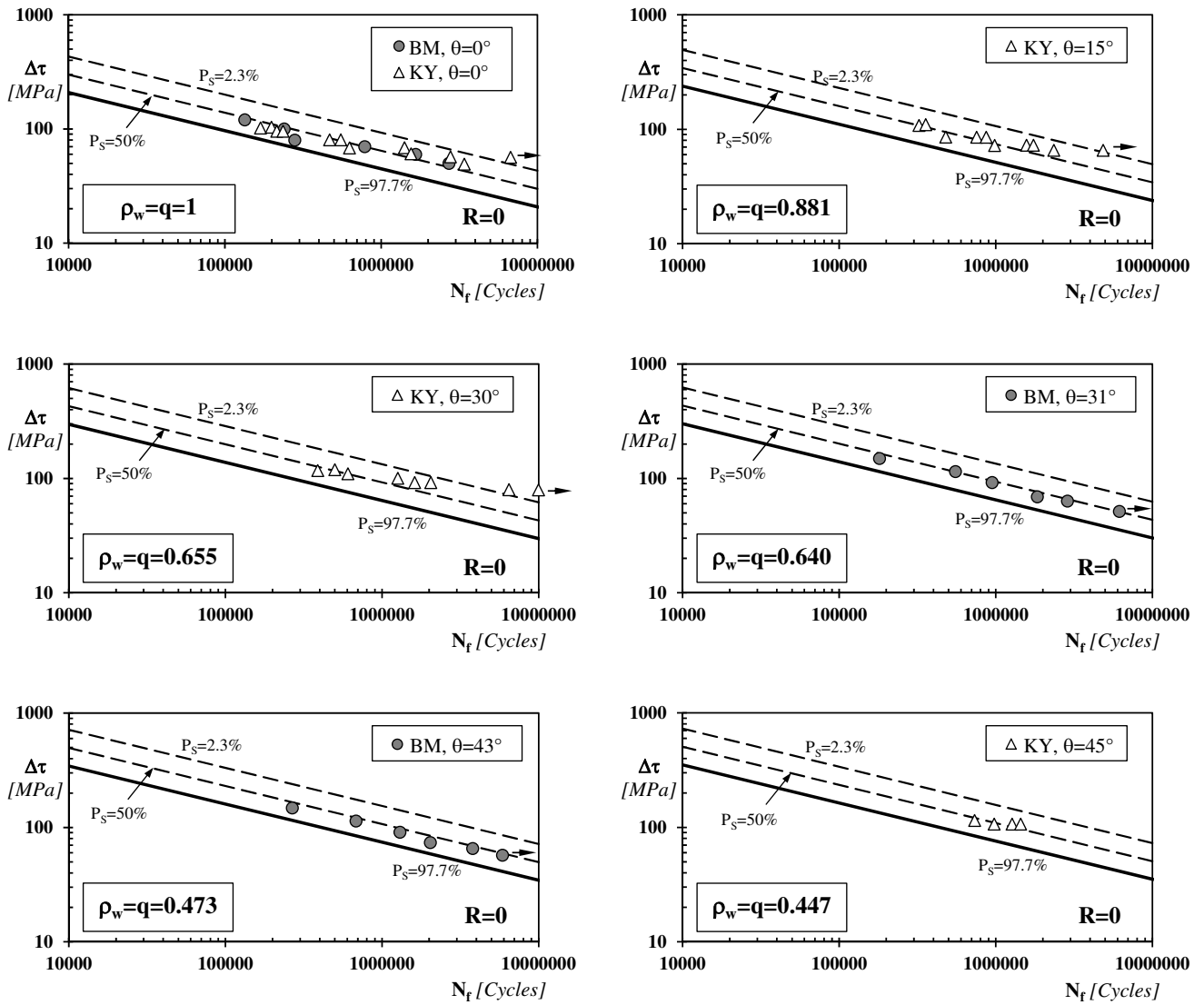

Figure 8: Accuracy of the MWCM in modelling the fatigue strength of the fillet welds tested by Booth and Maddox (BM) [32] and by Kim and Yamada (KY) [33].

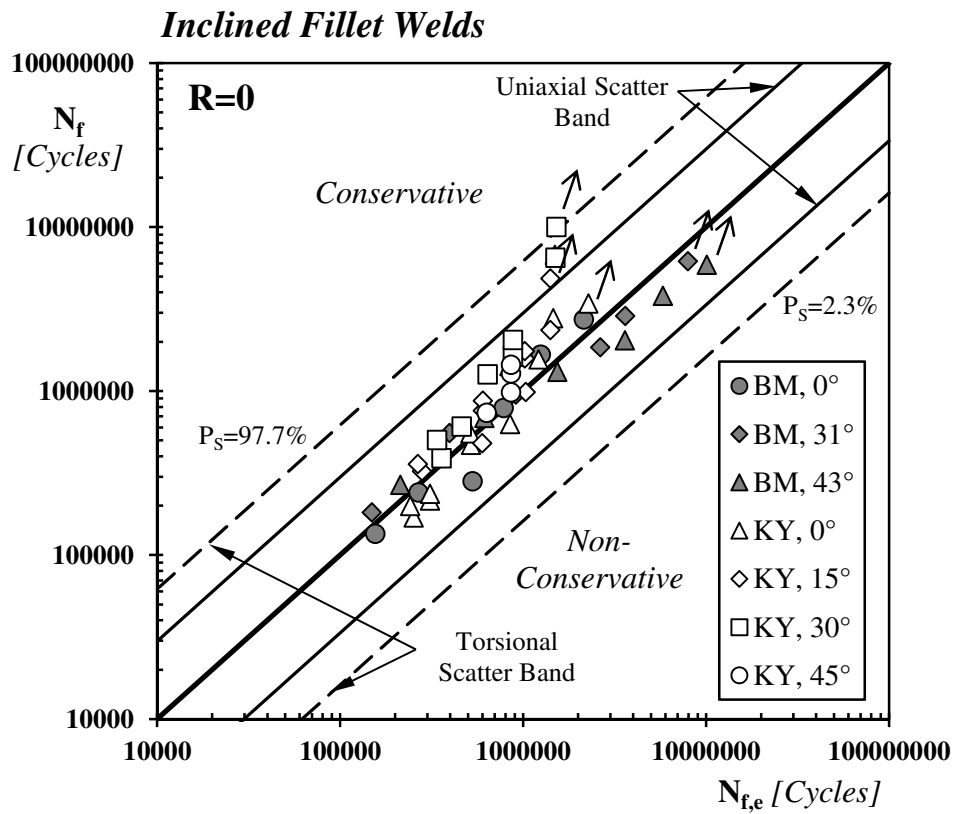

Figure 9: Accuracy of the MWCM in estimating the fatigue lifetime of the fillet welds tested by Booth and Maddox (BM) [32] and by Kim and Yamada (KY) [33] – Lifetime is estimated by calibrating the MWCM through design fatigue curves recalculated for $P_s=50\%$.