

This is a repository copy of *Absorption cross section measurement of stacked PCBs in a reverberation chamber*.

White Rose Research Online URL for this paper:

<https://eprints.whiterose.ac.uk/97625/>

Version: Accepted Version

---

### **Proceedings Paper:**

Parker, Sarah, Flintoft, Ian David [orcid.org/0000-0003-3153-8447](https://orcid.org/0000-0003-3153-8447), Marvin, Andy [orcid.org/0000-0003-2590-5335](https://orcid.org/0000-0003-2590-5335) et al. (6 more authors) (2016) Absorption cross section measurement of stacked PCBs in a reverberation chamber. In: 2016 Asia-Pacific Symposium on Electromagnetic Compatibility (APEMC2016). APEMC: Asia-Pacific International Symposium on Electromagnetic Compatibility, 18-21 May 2016 IEEE , CHN

<https://doi.org/10.1109/APEMC.2016.7522925>

---

### **Reuse**

Items deposited in White Rose Research Online are protected by copyright, with all rights reserved unless indicated otherwise. They may be downloaded and/or printed for private study, or other acts as permitted by national copyright laws. The publisher or other rights holders may allow further reproduction and re-use of the full text version. This is indicated by the licence information on the White Rose Research Online record for the item.

### **Takedown**

If you consider content in White Rose Research Online to be in breach of UK law, please notify us by emailing [eprints@whiterose.ac.uk](mailto:eprints@whiterose.ac.uk) including the URL of the record and the reason for the withdrawal request.

## **Absorption Cross Section Measurement of Stacked PCBs in a Reverberation Chamber**

S. L. Parker<sup>1</sup>, I. D. Flintoft<sup>1</sup>, A. C. Marvin<sup>1</sup>, J. F. Dawson<sup>1</sup>, S. J. Bale<sup>1</sup>, M. P. Robinson<sup>1</sup>, Ming Ye<sup>2</sup>, Changyong Wan<sup>3</sup> and Mengze Zhang<sup>3</sup>

<sup>1</sup>*Department of Electronics, University of York, Heslington, York YO10 5DD, UK*

<sup>2</sup>*Research and Development Center, Huawei Technologies AB, Kista, Sweden UK*

<sup>3</sup>*Huawei Industrial Base, Huawei Technologies Co. Ltd., Shenzhen, P. R. China*

Published in the Proceedings of the 7th Asia-Pacific International Symposium on Electromagnetic Compatibility & Signal Integrity and Technical Exhibition (APEMC 2016), Shenzhen, China, pp. 991-993, 18-21 May, 2016.

Accepted for publication 29/01/2016

DOI: [10.1109/APEMC.2016.7522925](https://doi.org/10.1109/APEMC.2016.7522925)

URL: <http://ieeexplore.ieee.org/xpl/articleDetails.jsp?arnumber=7522925>

© 2016 IEEE. Personal use of this material is permitted. Permission from IEEE must be obtained for all other uses, in any current or future media, including reprinting/republishing this material for advertising or promotional purposes, creating new collective works, for resale or redistribution to servers or lists, or reuse of any copyrighted component of this work in other works.

# Absorption Cross Section Measurement of Stacked PCBs in a Reverberation Chamber

S. L. Parker, I. D. Flintoft,  
A. C. Marvin, J. F. Dawson,  
S. J. Bale, M. P. Robinson  
Department of Electronics  
University of York  
York, UK  
[slp504@york.ac.uk](mailto:slp504@york.ac.uk)

Ming Ye  
Research and Development Center  
Huawei Technologies AB  
Kista, Sweden  
[ming.ye@huawei.com](mailto:ming.ye@huawei.com)

Changyong Wan, Mengze Zhang  
Huawei Industrial Base,  
Huawei Technologies Co. Ltd.  
Shenzhen, P. R. China  
[wanchangyong@huawei.com](mailto:wanchangyong@huawei.com)

**Abstract**—The Absorption Cross Section (ACS) of Printed Circuit Boards (PCBs) can be used to help determine how PCBs affect the internal electromagnetic (EM) field in a shielded enclosure and thus the enclosure shielding effectiveness. Stacked PCBs inside densely populated enclosures may not have the same ACS as the sum of the individual PCBs due to ‘shadowing’ effects. In this paper ACS measurement results from stacked PCBs are presented. The results show that stacking the PCBs close together reduces the ACS and this effect is increased with a greater number of PCBs.

**Keywords**—enclosure shielding, absorption cross section, reverberation chamber, printed circuit board

## I. INTRODUCTION

Shielding Effectiveness (SE) is a measure of how well an enclosure reduces the Electromagnetic (EM) field incident on it. It is a ratio of the incident power density on the enclosure to the power density inside the enclosure and is often specified for an empty enclosure. However, in reality the enclosure will not be empty and the SE will be affected by the energy absorbed by the contents [1]. It is therefore useful to be able to quantify the energy absorbed by typical contents such as PCBs and how multiple PCBs interact. Absorption Cross Section (ACS) measurements of individual PCBs in a reverberation chamber, using the method of Carlberg [2] have been reported in [3]. In this paper we examine the effect on the ACS when four PCBs were measured individually and in six different stacked configurations. The results show a ‘shadowing’ effect occurs which reduces the ACS of stacked PCBs.

## II. CALCULATION OF ACS

Average ACS of an object as measured in a reverberation chamber is defined as the ratio of the average power absorbed to the average power density of the incident field and is given by [1] as:

$$\langle \sigma_a \rangle = \frac{\lambda^2}{8\pi} \left( \frac{1}{G_{wo}} - \frac{1}{G_{no}} \right), \quad (1)$$

where  $\langle \sigma_a \rangle$  is average ACS,  $\lambda$  is the wavelength,  $G_{wo}$  is the mean net power transfer function with the object in the

reverberation chamber and  $G_{no}$  is the mean net power transfer function without the object. The brackets  $\langle \dots \rangle$  indicate averaging over stirrer positions and frequencies.  $G_{wo}$  and  $G_{no}$  are defined as:

$$G = \frac{\langle |s_{21}|^2 \rangle}{(1 - |s_{11}|^2)(1 - |s_{22}|^2)}, \quad (2)$$

where  $s_{21}$  is the transmission coefficient measured between two efficient antennas in the reverberation chamber and  $s_{11}$  and  $s_{22}$  are the reflection coefficients of the two antennas. Since here we are interested in relative ACS measurements the radiation efficiencies of the antennas are assumed to be unity.

Once the ACS of a PCB is known it can be used in the power balance model described by Hill [4] to compute the SE as the ratio of the incident and cavity power densities.

## III. PCBs UNDER TEST

The ACS of four PCBs in different stacked configurations is presented. Each PCB has dimensions of 283mm x 145mm and each has a variety of different components on it, including connectors, integrated circuits, passive components, and heat sinks. The four PCBs were taken from an Information and Communication Technology (ICT) system. The PCBs have been given the identification codes 2U\_PCB5, 2U\_PCB6, 2U\_PCB7 and 2U\_PCB8.

The ACS of each individual PCB was measured and the ACS of the stacked PCBs was measured in six different configurations; three measurements with a stack of 2 PCBs, two measurements with a stack of 3 PCBs and one measurement with all four PCBs. The PCBs in each configuration were grouped together as they would be when installed in the ICT enclosure. A plastic backplane was used to hold the PCBs together and the spacing between each PCB is 20mm as they would be installed in the enclosure. The backplanes of the PCBs were not connected together during these measurements; however, the front plates of the PCBs were in contact. All four PCBs are shown stacked together in Fig. 1.



Fig. 1. Photograph of all four PCBs stacked together with the plastic backplane.

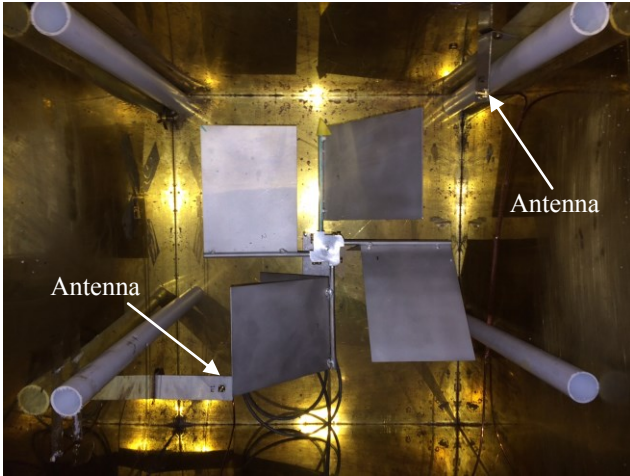

Fig. 2. View from above of the reverberation chamber setup showing the stirrer in the centre, supports for the polystyrene and antennas in the bottom left and top right.

#### IV. MEASUREMENT SET UP AND METHODOLOGY

The ACS measurements were carried out in a reverberation chamber with dimensions of  $0.6 \text{ m} \times 0.7 \text{ m} \times 0.8 \text{ m}$ . The measurement setup is shown diagrammatically in Fig. 2 and a photograph from the open top of the chamber is shown in Fig. 3. A stepped mechanical stirrer, controlled by a PC external to the reverberation chamber, was used to stir the chamber using 100 positions uniformly spaced over one rotation. A Vector Network Analyser (VNA) was used to collect a full set of S-parameters between two monopole antennas. 10,001 points were taken over the frequency range of 2 GHz to 20 GHz with a sweep time of 4.5 seconds. Frequency stirring, using a bandwidth of 50 MHz, was applied to the measurement data. A polystyrene sheet is used to support the PCBs in the working volume of the chamber above the stirrer.

Two sets of measurements are required to calculate the ACS; one with the object in the reverberation chamber and a second reference measurement with the reverberation chamber empty. One reference measure was carried out on each day measurements were being made. A validation measurement has been carried out for the procedure using objects with a known ACS [5]. Full details of the calibration of the measurement are given in [5], where it is also shown that the estimated uncertainty in the ACS is  $\pm 15\%$ .

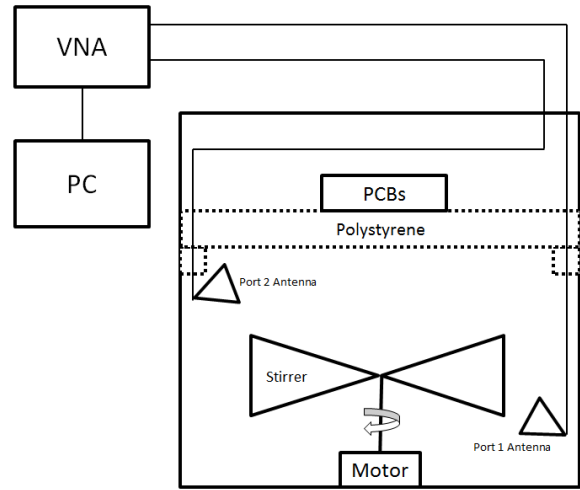

Fig. 3. Side view of the ACS measurement setup.

#### V. RESULTS

Fig. 4 shows the results for a pair of PCBs (2U\_PCB5 and 2U\_PCB6). The graph shows the ACS of each PCB when measured individually, the sum of the two individual PCB ACSs and the measured ACS of the two PCBs when stacked together. Fig. 5 shows the same effect when all four PCBs are stacked together. In both figures it can be seen that the ACS of the stacked PCBs is less than the summed ACSs of the individual PCBs. This shows that there is a ‘shadowing’ effect reducing the ACS when the PCBs are stacked together. This effect is larger when more PCBs are stacked together. For the four PCB case the ACS is reduced to approximately 75% of the summed ACS value with a difference of approximately  $5 \times 10^{-3} \text{ m}^2$ , which reduces slightly as frequency increases. For the two PCB case, below 10 GHz the ACS is reduced to approximately 75%, a difference of  $2.5 \times 10^{-3} \text{ m}^2$ . Between 10 GHz and 20 GHz the difference between the measured and summed ACS reduces to about  $10^{-3} \text{ m}^2$ , a reduction in ACS to approximately 85% of the summed value.

For the two PCB stack only two of the four PCB sides are subjected to shadowing; 50% of the PCBs surface area. The two outer PCB sides have nothing shadowing them. For the four PCB stack six of the eight PCB sides are subjected to shadowing, which is 75% of the PCBs surface area. This indicates why there is a greater reduction in ACS for a greater number of stacked PCBs.

Fig. 6 shows the measured ACS of all six configurations of stacked PCBs. The ACSs are grouped together depending on the number of PCBs stacked and it can be seen that as the number of PCBs in the stack increases the ACS also increases. However, as observed in Fig.4 and Fig. 5, as the number of PCBs in the stack increases the greater the reduction in ACS is.

The results show that the absorption of energy by the contents of an enclosure, in this case PCBs, is reduced due to a ‘shadowing’ effect caused by stacking the PCBs together. This affects the internal EM field in a shielded enclosure and so also affects the SE.

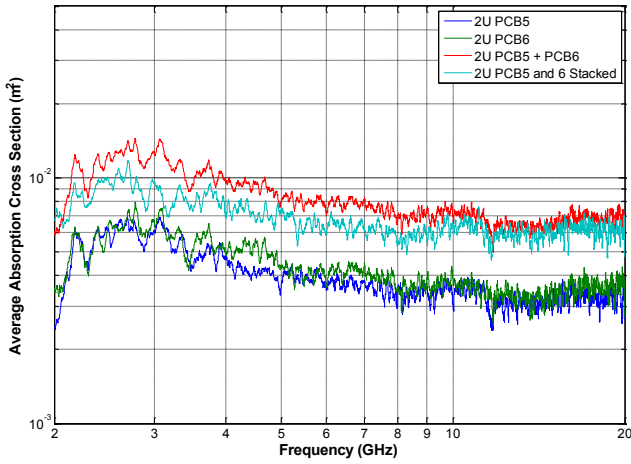

Fig. 4. Measured ACS of two stacked PCBs showing ACS of each individual PCB, the summation of these and the measured ACS of both PCBs when stacked together.

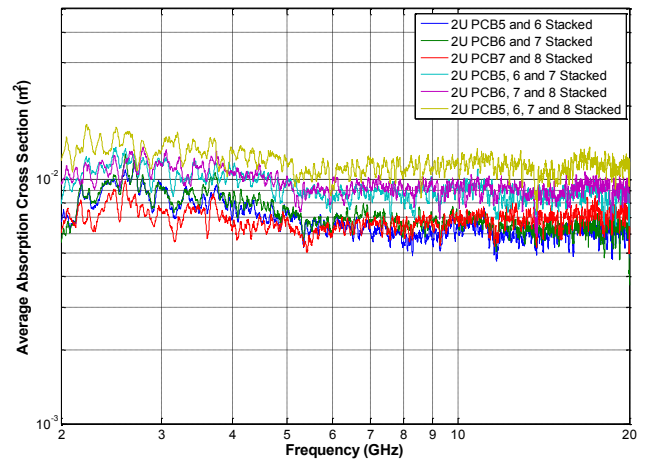

Fig. 6. Measured ACS of all stacked configurations of the PCBs.

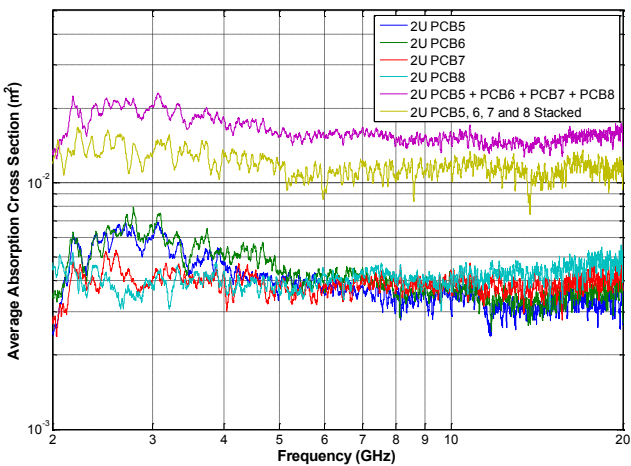

Fig. 5. Measured ACS of four stacked PCBs showing ACS of each individual PCB, the summation of these and the measured ACS of all PCBs when stacked together.

## VI. CONCLUSIONS

The ACS of four individual PCBs and six configurations of stacked PCBs have been measured in a reverberation chamber over the frequency range of 2 GHz to 20 GHz. The results show that there is a ‘shadowing’ effect which reduces the ACS of the stacked PCBs. This effect is increased as the number of PCBs in the stack is increased. This work has shown how measuring the ACS of stacked PCBs is useful for taking into account the contents of densely populated enclosures when calculating SE.

## ACKNOWLEDGEMENT

This work was supported by Huawei Technologies Co. Ltd., Shenzhen, P. R. China under Contract YB2014090010.

## REFERENCES

- [1] Marvin, A.; Dawson, J.; Ward, S.; Dawson, L.; Clegg, J. & Weissenfeld, A., "A proposed new definition and measurement of the shielding effect of equipment enclosures", *IEEE Transactions on Electromagnetic Compatibility*, vol. 46, no. 3, 459-468, Aug. 2004.
- [2] Carlberg, U., Kildal, P.-S., Wolfgang, A., Sotoudeh, O. and Orlenius, C., "Calculated and measured absorption cross sections of lossy objects in reverberation chamber," *IEEE Transactions on Electromagnetic Compatibility*, vol. 46, no. 2, pp. 146-154, May 2004
- [3] I. D. Flintoft, S. L. Parker, S. Bale, A. C. Marvin, J. F. Dawson and M. P. Robinson, "Measured average absorption cross-sections of printed circuit boards from 2 to 20 GHz", submitted to *IEEE Transactions on Electromagnetic Compatibility*.
- [4] D. A. Hill, M. T. Ma, A. R. Ondrejka, B. F. Riddle, M. L. Crawford and R. T. Johnk, "Aperture excitation of electrically large, lossy cavities", *IEEE Transactions on Electromagnetic Compatibility*, vol. 36, no. 3, pp. 169-178, August 1994.
- [5] I. D. Flintoft, S. J. Bale, S. L. Parker, A. C. Marvin, J. F. Dawson and M. P. Robinson, "On the measurable range of absorption cross-section in a reverberation chamber", *IEEE Transactions on Electromagnetic Compatibility*, accepted for publication.