



UNIVERSITY OF LEEDS

This is a repository copy of *Material characterisation of lightweight disc brake rotors*.

White Rose Research Online URL for this paper:

<http://eprints.whiterose.ac.uk/97066/>

Version: Accepted Version

Article:

Alnaqi, AA, Kosarieh, S orcid.org/0000-0002-0210-7165, Barton, DC orcid.org/0000-0003-4986-5817 et al. (2 more authors) (2018) Material characterisation of lightweight disc brake rotors. Proceedings of the Institution of Mechanical Engineers, Part L: Journal of Materials Design and Applications, 232 (7). pp. 555-565. ISSN 1464-4207

<https://doi.org/10.1177/1464420716638683>

Reuse

Items deposited in White Rose Research Online are protected by copyright, with all rights reserved unless indicated otherwise. They may be downloaded and/or printed for private study, or other acts as permitted by national copyright laws. The publisher or other rights holders may allow further reproduction and re-use of the full text version. This is indicated by the licence information on the White Rose Research Online record for the item.

Takedown

If you consider content in White Rose Research Online to be in breach of UK law, please notify us by emailing eprints@whiterose.ac.uk including the URL of the record and the reason for the withdrawal request.



eprints@whiterose.ac.uk
<https://eprints.whiterose.ac.uk/>

Material characterisation of lightweight disc brake rotors

¹Alnaqi, Abdulwahab A.*; ²Kosarieh, Shahriar; ²Barton, David C.; ²Brooks, Peter C.;
³Shrestha, Suman

¹Dep. of automotive and Marine Engineering Technology, College of Technological Studies - PAAET, Kuwait; ²University of Leeds, United Kingdom; ³Keronite International Ltd, United Kingdom

* Corresponding author. Tel: +965-99629911.

E-mail address: aa.alnaqi@paaet.edu.kw or eng_abdulwahab1982@yahoo.com (A.A. Alnaqi).

Abstract

Alumina coated lightweight brake rotors were investigated to evaluate the effect of coating properties on their friction performance and thermal durability. An alumina ceramic coating on AA6082 aluminium alloy (Al-Alloy) and on 6061/40SiC aluminium metal matrix composite (Al-MMC) prepared by plasma electrolytic oxidation (PEO) was studied using a programme of brake dynamometer and material characterisation tests. The results showed that the PEO alumina layer adhered well to the Al-alloy substrate and was more uniform and durable when compared to that on the Al-MMC. The PEO layer significantly improved the hardness of the rotor surface for both Al-alloy and Al-MMC substrate. The coated Al-alloy disc brake rotor was demonstrated to give good thermal and friction performance up to high rubbing surface temperatures of the order of 550°C but the rotor eventually failed due to temperature build-up at a critical location.

Keywords: Coating, aluminium oxide, plasma electrolytic oxidation, disc brake rotor, material characterisation.

List of Abbreviations

3D	Three Dimension
Al	Aluminium
Al-MMC	Aluminium metal matrix composite
Al-Alloy	Wrought aluminium alloy
DC	Direct Current
EDX	Energy-dispersive X-ray spectroscopy

PEO Plasma electrolytic oxidation

SEM Scanning electron microscope

1. Introduction

An automotive brake system is responsible for converting the kinetic energy of the vehicle to thermal energy which is then dissipated through the disc brake rotor and other parts. Most of the automotive industry use grey cast iron or steel for manufacturing disc brake rotors because of the good thermal properties and high melting point of ferrous-based materials. The main disadvantage of the conventional cast iron disc brake rotor is its weight, which has an impact on fuel consumption and vehicle emissions. The automotive industry is under huge pressure to reduce vehicle emissions by an average of 10% by 2015, according to the European Federation for Transport and the Environment [1]. This has motivated the automotive industry to find ways to reduce vehicle weight by using lightweight materials.

Aluminium and its alloys have properties (low density, high specific heat and high thermal conductivity) which make them ideal for various engineering applications. Also, aluminium is a passive material which can naturally form a dense oxide layer to give corrosion protection. Many researchers have investigated the possibility of using aluminium and its alloys in the disc brake rotor instead of the conventional cast iron or steel [2-5]. It has been found that the main disadvantage of aluminium alloy is the relatively low maximum operating temperature, which is of the order of 400°C, and this has led researchers to investigate the possibility of using some type of coating to protect the aluminium substrate during extreme braking conditions. Surface modification of the alloy using processes like thermal spraying [6] and anodizing [7] have been used in order to improve wear resistance and to protect the substrate from high temperatures. Aluminium alloy reinforced with ceramic (SiC) particles to form a metal matrix composite (MMC) has also been used to increase the surface resistance and strength of the alloy but again has been found limited to a maximum surface temperature of around 450°C [5]. Another type of surface treatment is plasma electrolytic oxidation (PEO) which provides a good thermal barrier of aluminium oxide because of its low thermal conductivity [8] and good wear resistance [9, 10].

Plasma electrolytic oxidation (PEO), which is variously known as micro-plasma oxidation, plasma electrolytic anode treatment and spark/discharge anodic coating [11], is an electrochemical surface treatment process that generates an oxide coating on a metal substrate [12]. PEO coatings are formed by the oxidation of metal substrate in an aqueous electrolyte

through a series of localized electrical discharge events [8, 11, 12]. The oxidation process is produced by passing a controlled electrical current through an electrolyte solution, which causes a plasma discharge to be formed around the desired component [13, 14]. The specified series of discharges allows oxide growth to form films on aluminium with a thickness of up to 100 μm [15]. The main advantages of the PEO alumina coating are its good wear resistance, good corrosion resistance and low thermal conductivity [8, 11, 13, 15]. Furthermore, the interfacial adhesion between the substrate and the coating is excellent because of the substrate chemical conversion rather than simple deposition.

In the current study, both aluminium alloy (6082-T6) and aluminium metal matrix composite (6061/40SiC, hereafter referred to as “Al-MMC”) were used to investigate the thermal and tribological performance of solid small scale brake rotors. Five small scale solid brake rotors were investigated: grey cast iron, forged aluminium alloy (6082), the same 6082 alloy but with an alumina surface layer applied by plasma electrolytic oxidation (PEO), cast Al-MMC, and the same Al-MMC again with a PEO alumina surface layer. The PEO treatment for both aluminium alloy and Al-MMC composite rotors was carried out by Keronite International Ltd. The thermal performance of the five discs is described in [16] whilst the main focus of the current study is to characterise the mechanical and surface properties of the coated and uncoated aluminium based disc brake materials.

2. Experimental methods

a. Small scale brake design and dynamometer testing

The overall dimensions of the small scale disc and brake pad were sized based on a newly developed scaling methodology [17, 18] and are shown in Figure 1. The basic philosophy of the scaling methodology was to produce very similar tribological conditions (rubbing speed, interface pressure and temperature) to that experienced by a full sized automotive brake.

The thermal performance of the various disc brake materials was comprehensively investigated using a 2 kW small scale brake dynamometer and an existing 45 kW full scale brake dynamometer, as shown in Figures 2 and 3 respectively. A series of proofing tests were performed on the small scale dynamometer according to the standard SAE test matrix [17]. The main reason for using the full scale dynamometer was to enable severe drag braking events to be simulated in order to test the small scale brake rotors to their limits.

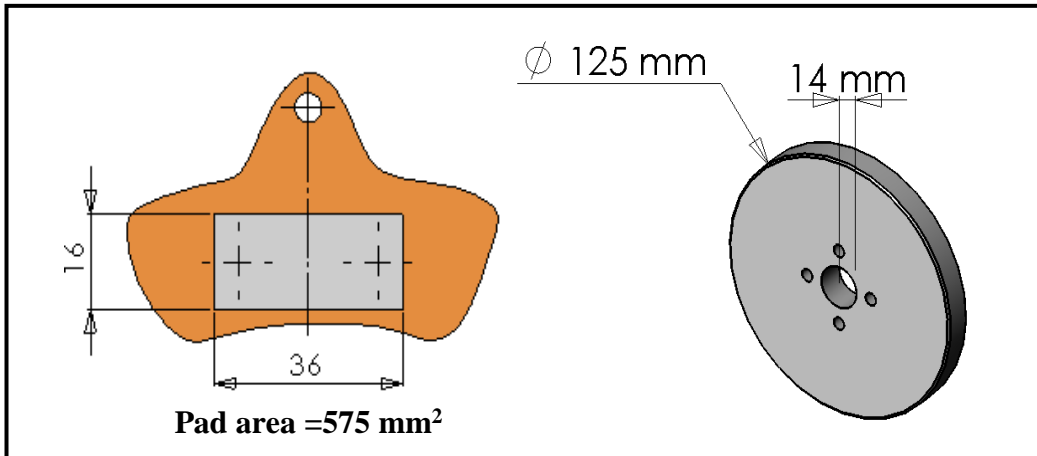

Figure 1: Small scale disc and pad geometry

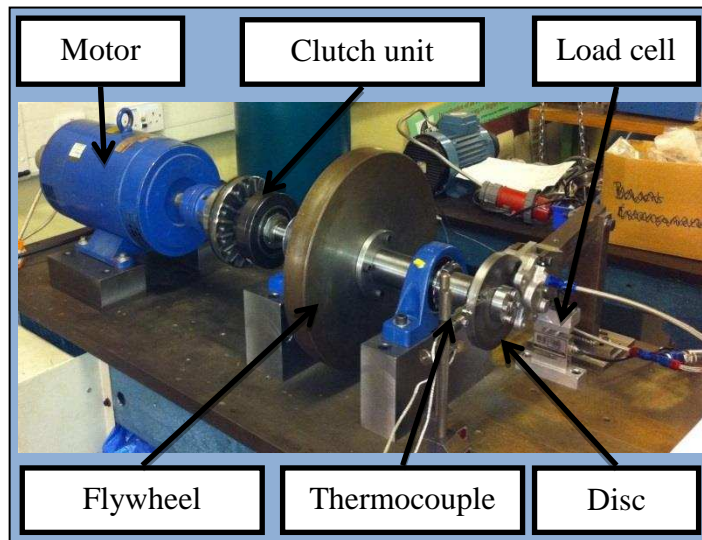

Figure 2: General overview of the small scale test rig

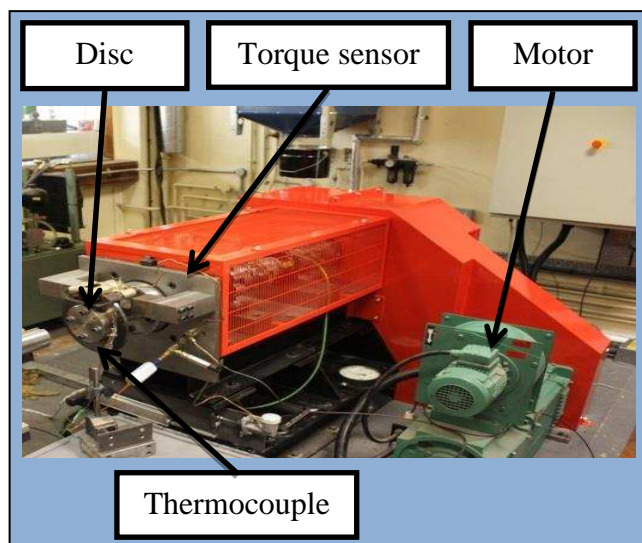

Figure 3: General overview of the full scale test rig

b. Materials

The substrate materials used to manufacture the small scale disc brake rotors were aluminium alloy (6082-T6) and Al-MMC (6061/40SiC); their chemical compositions were measured using Energy-Dispersive X-ray Spectroscopy (EDX) analysis (Carl Zeiss SEM EVO MA15) and the results are shown in Table 1. The PEO coatings used in this study were characterised in terms of roughness, thickness, hardness, surface uniformity and adhesion. The thermal and tribological performance of the various small scale discs have been presented in detail elsewhere [16, 17, 19].

The brake pads were provided by TMD Friction Company and the friction material was designed specifically for use against aluminium discs with ceramic surfaces. It was an organic based friction material containing a low amount of metallic compounds (LowMet).

Table 1: Elemental composition of disc brake rotors (weight %) from EDX analysis

Reference/element (wt%)	Al (6082)	Al-MMC
Si	1.65	28.93
Mg	0.59	0.2
Mn	1.09	0.02
Fe	1.25	0.14
Cr	0.13	0.04
Cu	0.17	0.19
Zn	0.05	--
Ti	0.07	0.02
Al	94.97	35.17
C	--	35.2

c. Preparation of PEO coating discs

The PEO treatment for all disc brake rotors was carried out by Keronite International Ltd. Plain brake discs, of $\text{Ø}125\text{mm} \times 14\text{mm}$ thickness as shown in Figure 1, were first machined from AA6082 alloy and Al-MMC billets. The disc specimens were degreased with acetone, then treated using the Keronite processing system that utilised a pulsed bipolar AC 160 kW power source and an alkaline electrolyte bath. General parameters of the PEO process used are presented in Table 2. The PEO coating was generated on the exposed surfaces of each rotor and grown to a nominal thickness of 30-50 μm which was confirmed using an induction thickness gauge by Keronite Company. The coating thickness was later confirmed using an optical microscope at Leeds University (see section 3).

Table 2: Typical process parameters during Keronite PEO coating for AA6082 alloy and Al-MMC

Parameter	PEO process	Parameter	PEO process
Pre-treatment	Degrease only	Coating rate ($\mu\text{m}/\text{min}$)	1-4
Electrolyte	Proprietary alkaline free of Cr, V or other heavy metals	Voltage (V)	200-900
Total salt content (%)	<4	Process temp ($^{\circ}\text{C}$)	12-30
Typical pH	7-12	Coating formation method	Plasma oxidation
Nominal thickness (μm)	15-60	Surface appearance	Grey

d. Sample preparation

The cross sectional views of the coated samples were prepared by cutting a specified section of the disc after the brake testing was finished and then using an automatic press machine to mount the samples in Bakelite resin.

Metallographic preparations (mechanical grinding and polishing) were carried out for the cross sectional samples only. Each sample was ground using SiC paper with gradually finer grit size starting at 240 and rising to 1200 grade. The grinding rotation speed was kept constant for all paper sizes, at 300 rpm, and the sample was rotated 90° after each paper. After grinding, the sample went through a polishing process, where a $3\ \mu\text{m}$ pile based diamond suspension was used, until a mirror-like surface was obtained. This procedure was carried out in accordance with standard guidelines [20].

e. Material characterisation

The main aim of this study was to evaluate the lightweight brake rotor materials before and after brake testing in order to investigate whether the proposed coated disc brake is capable of withstanding real braking conditions. Surface morphology, porosity and structure were investigated using optical and scanning electron microscopes (SEM). The optical and

scanning microscopes used in the current study were a Leica optical microscope and Carl Zeiss SEM EVO MA15, respectively.

The roughness, wear profile and transfer layer thickness of the discs were measured and analysed by NP Flex optical interferometer (Brucker). The roughness analysis was carried out in order to evaluate the Ra value at four different positions across the wear scar as shown in Figure 4. The trace length was 22mm across the wear scar at positions P₁ to P₄ inclusive. The analysis was performed using a Gaussian Filter with 0.8mm cut- off and 100:1 bandwidth least squares fit. The Zeiss EVO MA15 SEM was used to investigate the transfer layer and durability of the coatings. The SEM was also combined with an Oxford Instrument Energy Dispersive X-ray (EDX) analysis system to analyse elemental compositions of the materials used in the research.

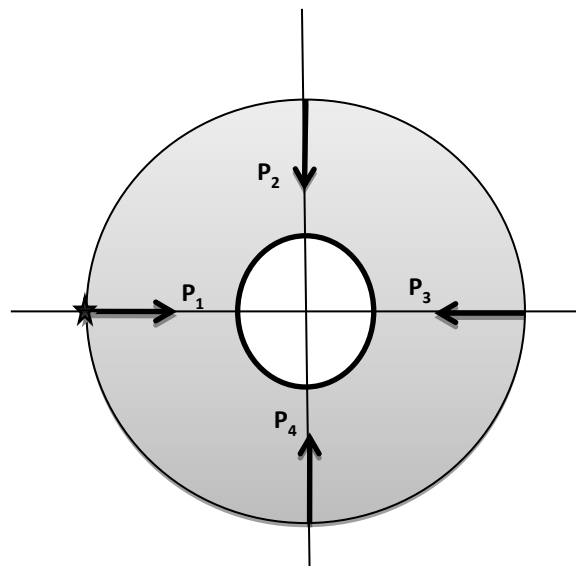

Figure 4: Trace positions for roughness analysis on the small scale disc brake

A Vickers micro indentation hardness tester (Mitutoyo HM-122 Hardness testing machine) was used to measure the mechanical properties of the disc brake rotor substrates and coatings. Since the indentations made by the Vickers micro-hardness tester were more than 10% of the coating thickness, it was necessary to make the measurements on the polished cross-sectional samples prepared as described in Section 2d. It was difficult to investigate the hardness of the PEO coating without polishing the surface of the sectioned samples as it was not easy to see the indentation on the coating surface. The micro hardness of the coating and substrate was evaluated using standard analysis technique and the measurements were taken from at least

four different places on the tested surfaces.. The test machine was calibrated before testing using the standard calibration kit.

3. Results and discussion

a. Dynamometer tests

The five small scale discs were tested on the small scale and full size dynamometers according to the representative SAE test matrix [17]; the surface temperature of the discs were monitored during all the tests using rubbing thermocouples and a high speed thermal imaging camera (FLIR X6540SC). The friction coefficient between the disc and pad surfaces was evaluated from the hydraulic line pressure (normal load) and brake torque measured using an appropriate transducer. The discs were loaded to their upper limits on the full size dynamometer in order to observe the effect of elevated temperature on the friction and coating performance.

The plain aluminium alloy disc did not complete the full programme of tests as scratches started to appear on the surface at a relatively low temperature of 200°C [16]. Typical rubbing surface temperature time histories for the remaining 3 discs under similar arduous braking duties are shown in Figure 5. Although normally one would expect the surface temperature of a coated disc to be higher due to the thermal barrier effect, it can be seen that the temperature reached by the coated Al-MMC disc was about the same as that of the uncoated MMC. This was because the coated MMC disc experienced much greater brake fade (reduction in CoF) at elevated temperature than the uncoated MMC which limited the temperature build-up. The maximum surface temperature reached during the standard programme was 500°C for the PEO-Al Alloy, as shown in Figure 5, since this rotor suffered lower brake fade than the coated Al-MMC and was therefore able to maintain its effective braking performance even at these elevated temperatures.

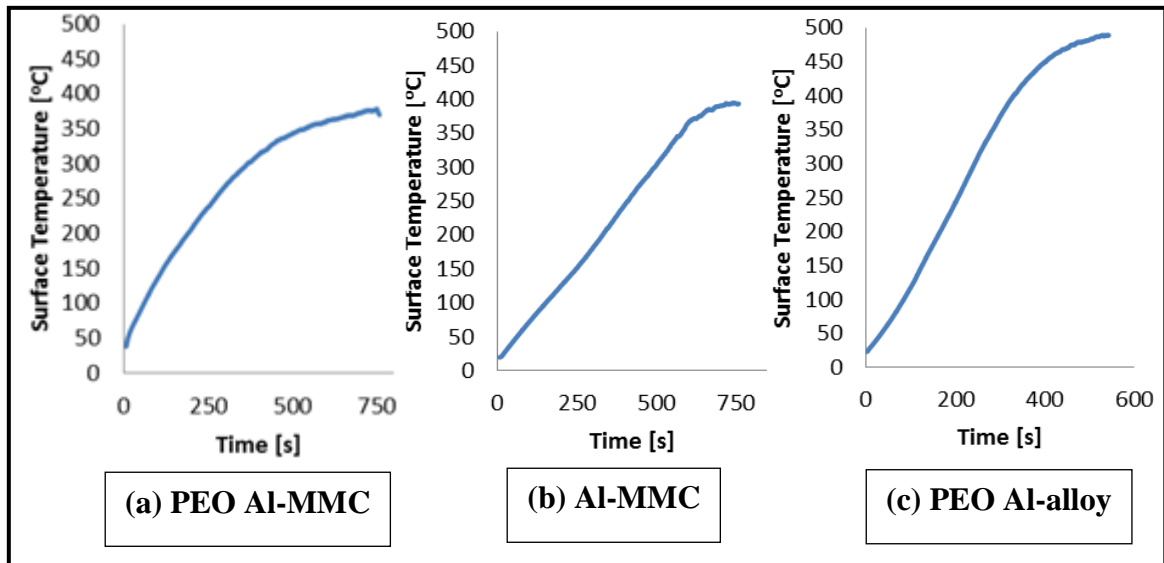

Figure 5: Maximum surface temperature of the disc brakes.

The average coefficients of friction during dynamometer testing at surface temperatures below 200°C are shown for each disc material in Figure 6. It can be seen that the grey cast iron disc had the highest coefficient of friction of almost 0.32, while the coated disc brake rotors had only slightly lower coefficients of friction in the range 0.25-0.3. The plain Al-MMC disc had the lowest average coefficient of all at a level of about 0.2 which is not acceptable for a modern disc brake. It should however be noted that the friction material had been optimised for the alumina coated discs and not for the uncoated MMC surface on which silicon carbide particles may be exposed.

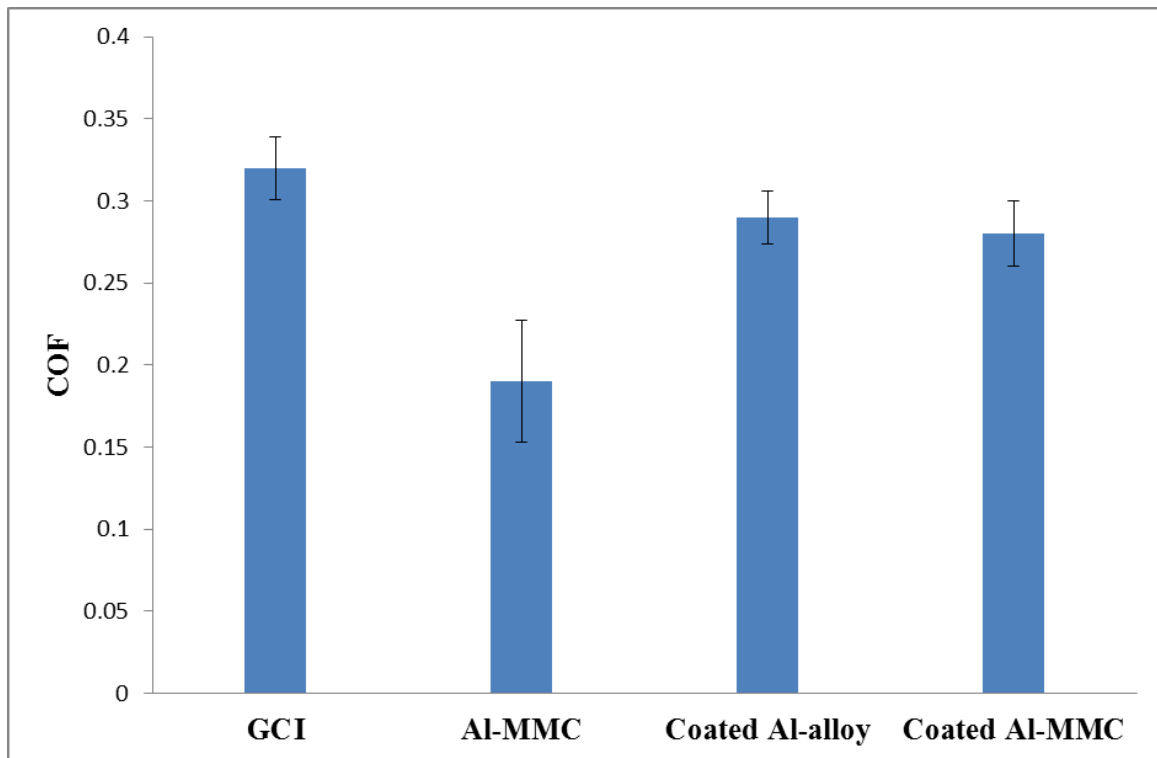

Figure 6: Average coefficient of friction (COF) for the small scale disc brake rotor (error bar shows standard deviation of measured value)

b. Failure mode of the coated aluminium alloy rotor

The coated aluminium alloy disc brake rotor was tested under extreme drag braking conditions until the rotor failed catastrophically when the rubbing surface temperature exceeded 550°C. The remains of the brake rotor after this catastrophic failure are shown in Figure 7. Visual inspection of the failed rotor showed that the failure occurred around the inner radius of the rubbing surface as shown in Figure 6a which is where the disc material experiences maximum thermal stress (due to temperature gradients) and high mechanical stress (due to the transmitted torque) in a region where the temperatures are also very high. Although the disc shattered into a number of separate pieces, Figure 7b, the coating on the rubbing surface remained fully attached to the pieces and to the remaining central rotor section. The fracture surface of the failed alloy material had a very fibrous appearance (Figure 7c) indicating that the highly uniaxial nature of the crystallised structure of the wrought alloy had induced an intergranular brittle fracture mode.

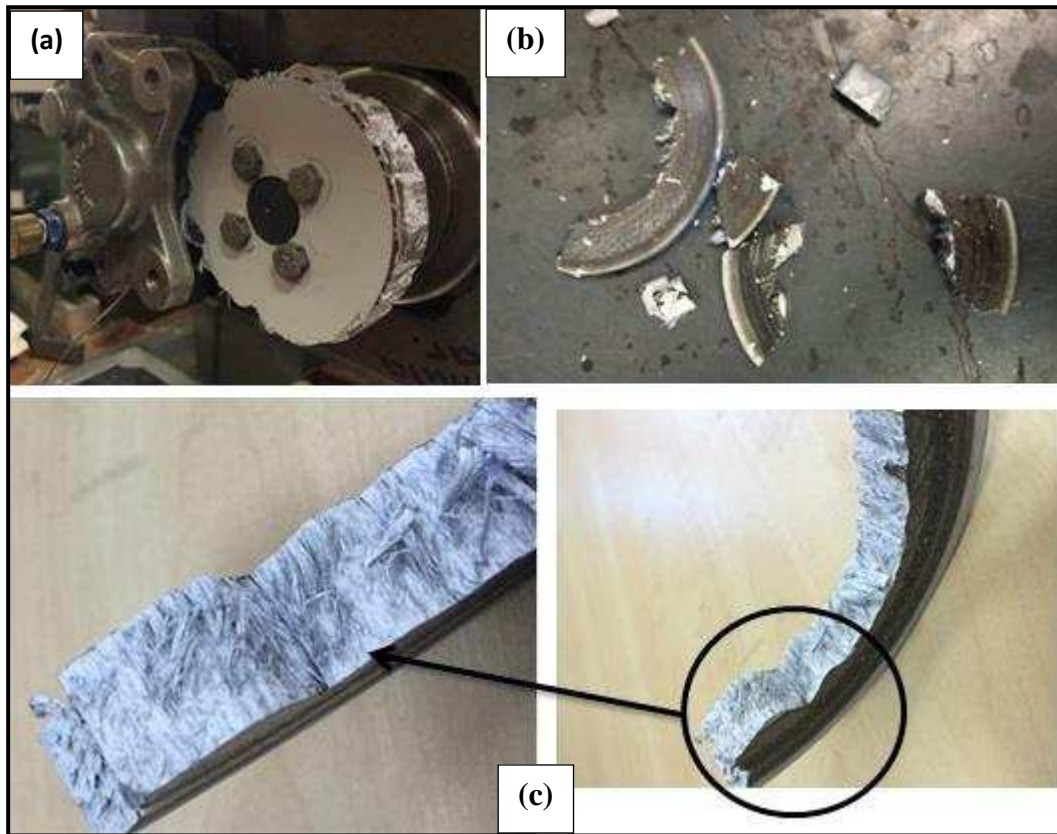

Figure 7: Coated wrought aluminium disc brake rotor after extreme braking.

The aluminium alloy rotors were machined from a forged billet in which the grain boundaries were formed predominantly in the axial direction with respect to the rotor (normal to the rubbing surface). It is postulated that this led to failure at the grain boundaries around the circumferences of the disc. In order to confirm this, small samples of the rubbing surface of the failed rotor were examined using SEM. The coating layer of the prepared sample was removed by grinding in order to investigate the grain boundary structure and mode of failure of the substrate only. The sample was coated with gold in order to create acceptable SEM images as shown in Figure 8. The white spots on the sample consist of silicon, iron, magnesium, manganese and copper. These micrographs tend to confirm the intergranular brittle fracture mode of the alloy substrate.

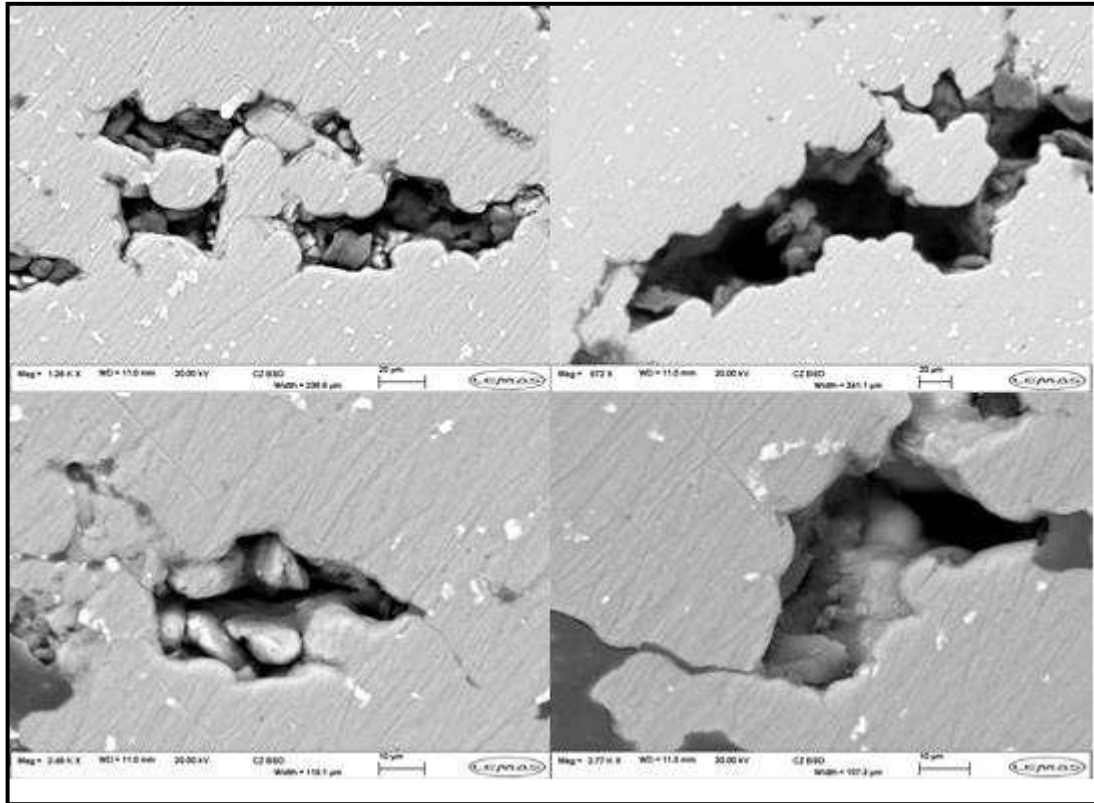

Figure 8: SEM images of the coated aluminium alloy substrate after failure.

c. Surface roughness before and after dynamometer testing

The surface roughness of all the discs was measured before and after test, with the results shown in Figure 9, which presents the average Ra values. The roughness value is important to consider in this work as it is likely to affect the wear rate of the friction material. It can be seen that there was no significant difference between the roughness values before and after the braking tests for the cast iron rotor. However the surface roughness of the plain Al-MMC increased substantially after braking tests due to the softening of the alloy matrix on the rubbing surface at the relatively high temperatures reached [16]. In contrast, the roughness values for both coated rotors were seen to decrease after testing. It can be seen that the coated Al-MMC has the highest roughness before testing, due to the surface morphology of the MMC substrate and the poor quality of the PEO coating for this material (see below). The large reduction in roughness after testing could be due to asperities on the surface of the coated Al-MMC rotor becoming detached due to interactions with the brake pad. No results are presented for the uncoated Al-alloy after testing since this material become quite severely scratched at relatively low temperatures.

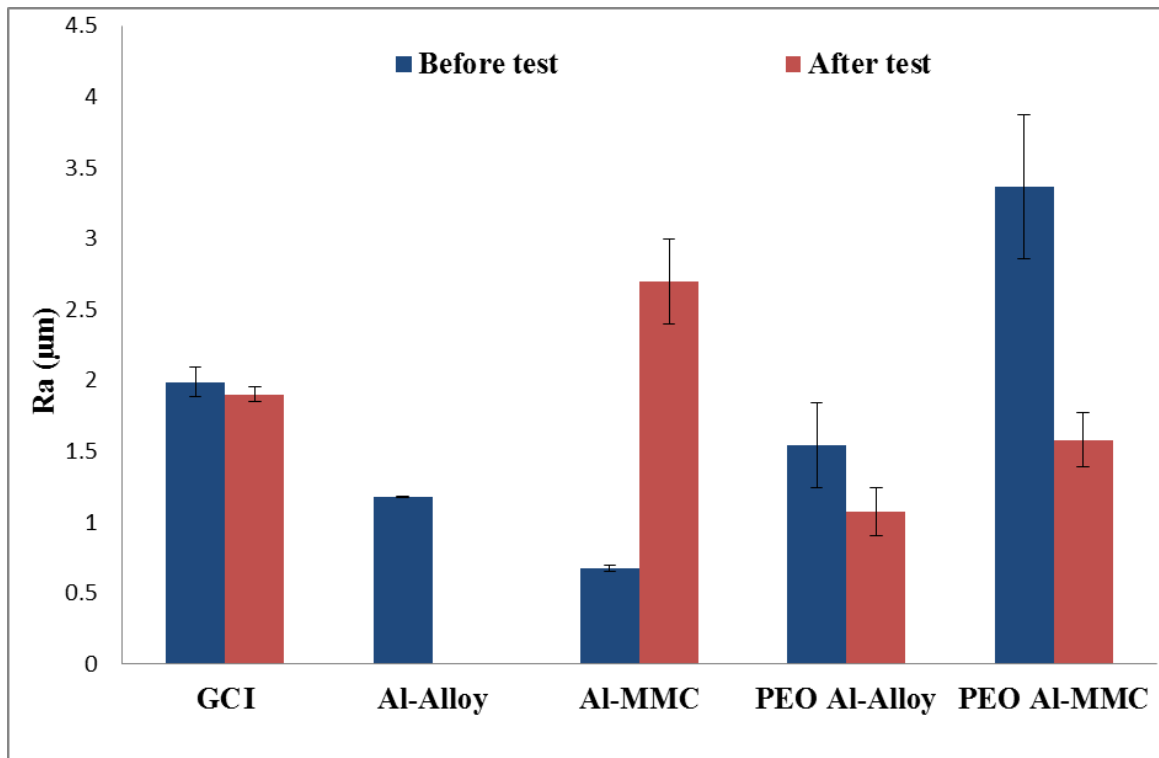
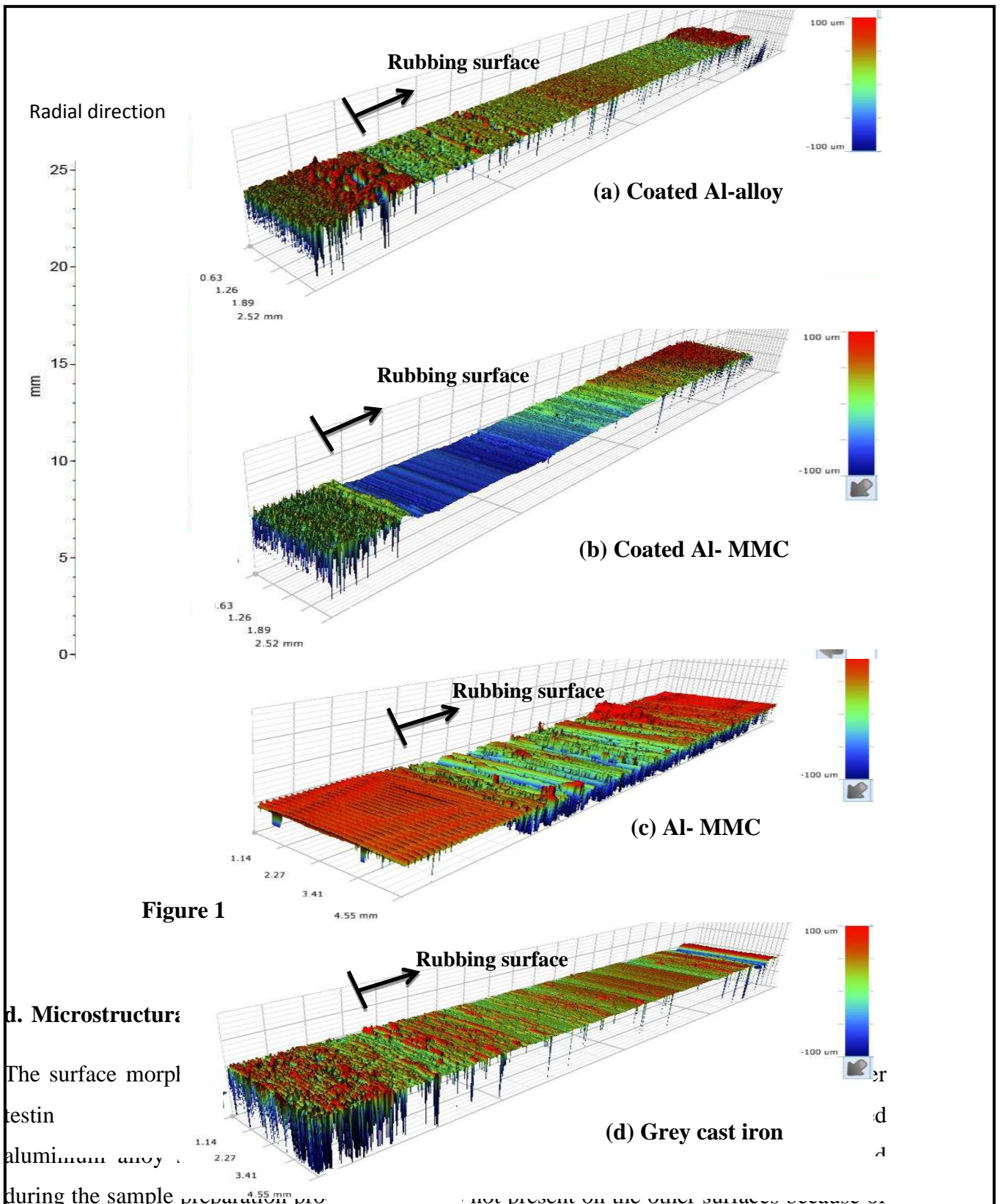

Figure 9: Roughness values for the discs before and after the braking tests (error bar shows standard deviation of measured value between different traces)

The optical interferometer was used to investigate the surface profiles after the braking tests, as shown in Figure 10, which represents the 3D profiles of the different disc brake rotors in the radial direction including both the rubbing and non-rubbing (non-wear) surfaces. It can be seen that both coated and uncoated Al-MMC (Figures 10(b) and 10(c)) were affected by the various braking tests while the coated Al-alloy Figure 10(a) had a more uniform and stable surface even when compared to the standard grey cast iron surface that is shown in Figure 10(d). In addition, the plain Al-MMC disc rubbing surface started to suffer from scratches when the surface temperature recorded by the sliding thermocouples exceeded 250 °C because the aluminium on the rubbing surface began to soften and became susceptible to third body damage.



the higher hardness. The white spots shown on this micrograph indicate the silicon phase of the aluminium substrate. The surface morphology of the uncoated aluminium MMC is shown in Figure 11(b). In this SEM image, the dark phase represents the metal alloy and the white phase represents the SiC particles.

The surface morphologies of the PEO coating on the Al-alloy and the Al-MMC appear very similar, as shown in Figures 11(c) and 11(d) respectively. It can be seen that many particles of spherical, lamellar or irregular shapes have formed on the surface due to volcano-like eruptions during the PEO process. Likewise, it can be seen that a number of small shrinkage holes have formed on the surface. Thus, the PEO surface morphologies are characterised by macro-particles which resulted from the spark discharge during the layer growth [21-23].

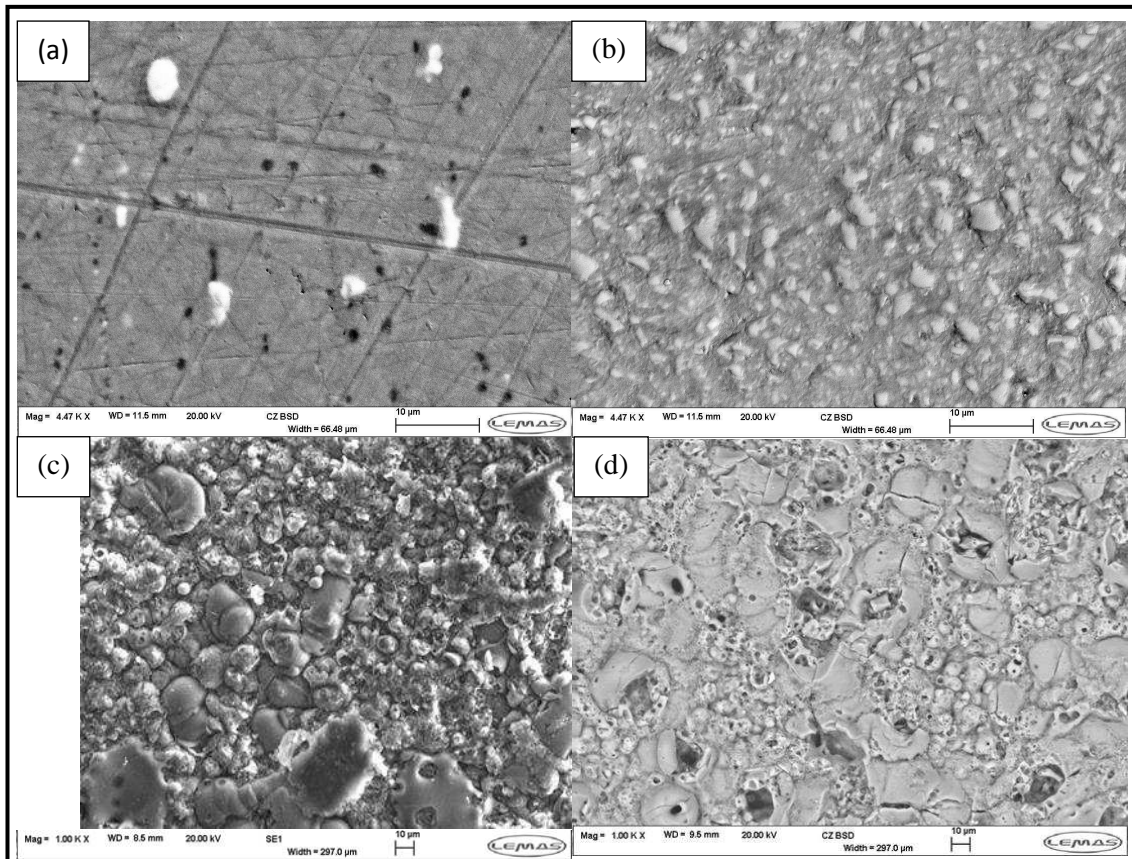

Figure 11: SEM images showing the surface morphology of: (a) Al-Alloy (6082), (b) Al-MMC (AMC640XA), (c) PEO coating of Al-alloy and (d) PEO coating of Al-MMC.

The transfer layer formed on the coated aluminium alloy disc brake rotor was investigated using the interferometer along with the optical and scanning microscopes. It was found that the transfer layer has an average thickness of 2-4 μm. Figure 12 shows the EDX map image of the coated aluminium alloy disc after testing. The dark patches present on the upper image in Figure 12(b) indicate that material has transferred from the brake pads across to the rubbing surface. This so called transfer layer is a combination of the disc and pad materials

and is a critical characteristic of the friction pair since it exerts influence over the thermal interactions between the disc and the pad.

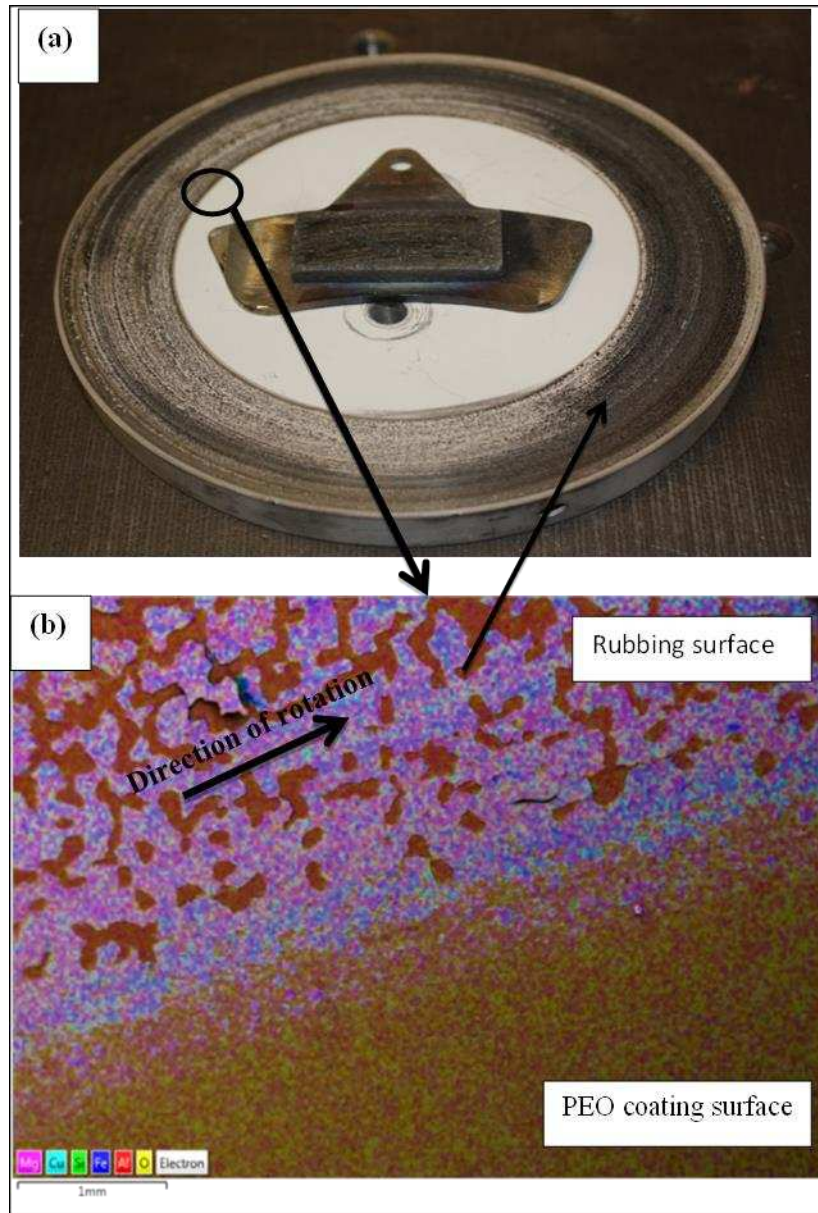

Figure 12: EDX map image of the coated aluminium alloy disc brake rotors after testing.

Figure 13 shows the SEM micrograph images of the coated aluminium alloy and aluminium MMC cross sections after testing. It appears that the Al-alloy has a very dense and uniform coating compared with that formed on the Al-MMC [9, 24]. This is believed to give a tremendously hard and robust tribo surface with a stable coefficient of friction and, in addition, some good thermal barrier characteristics.

On the other hand, the existence of a high proportion of SiC particles in the Al-MMC presents a real challenge to the PEO process, or any similar surface modification process. It means that the coating is not very uniform and has high levels of porosity, which reduce the coating hardness significantly when compared to that formed on the plain alloy, as shown in Figure 14. Although the PEO coating has been shown to improve the corrosion resistance of the Al-MMC substrate [9, 24], the durability was likely to be poorer compared to the coated aluminium alloy due to its lower density and lower hardness. Also potential crumbling and subsequent detachment of the Al₂O₃ particles plus some SiC could result in three-body abrasion wear between the coated Al-MMC disc and the brake pads.

It was found from micrographs such as those shown in Figure 13 that the average coating thickness for the Al-MMC substrate was 30 µm before the test and 20 µm after the test, while the coating thickness of the coated Al-alloy was 50 µm before the test and 49 µm after the test. This tends to support the notion that the PEO coating on the Al alloy rotor is much more durable than that on the Al-MMC.

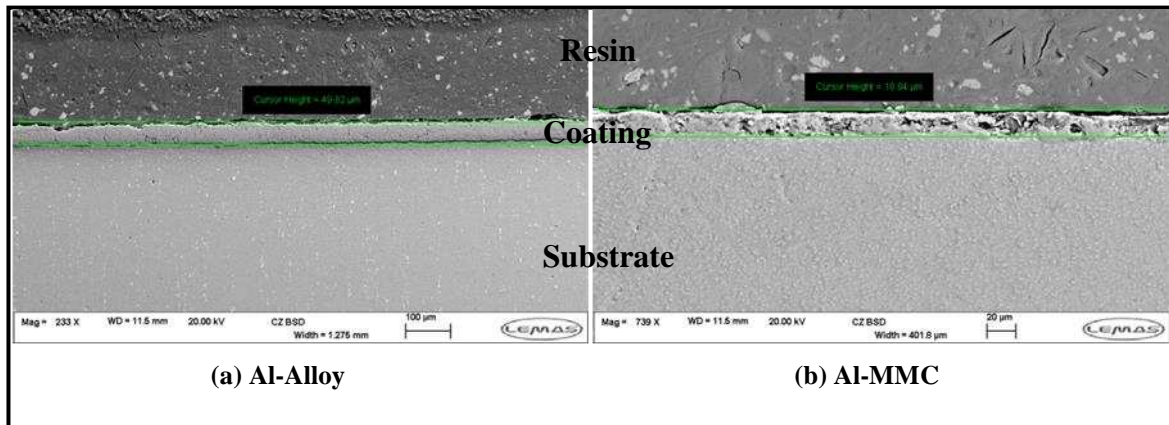

Figure 13: SEM images of the coated aluminium alloy and aluminium MMC cross section after testing [16].

e. Hardness measurements

Micro-hardness tests were carried out on cross-sections of the plain alloy and MMC brake rotors with and without PEO coating with the results shown in Figure 14. The uncoated Al-MMC has a significantly higher micro hardness of around 200 HV compared to the plain alloy due to the hardening effect of the SiC particles. It can be seen that the PEO coating on

the aluminium alloy coating achieved the highest hardness of 1400 HV while the hardness of the same coating on the Al-MMC was only 980 HV. This is an indication of the inferior quality of the PEO coating formed on the MMC compared with that on the plain alloy. The results obtained showed good agreement with other reported results [15, 21, 23].

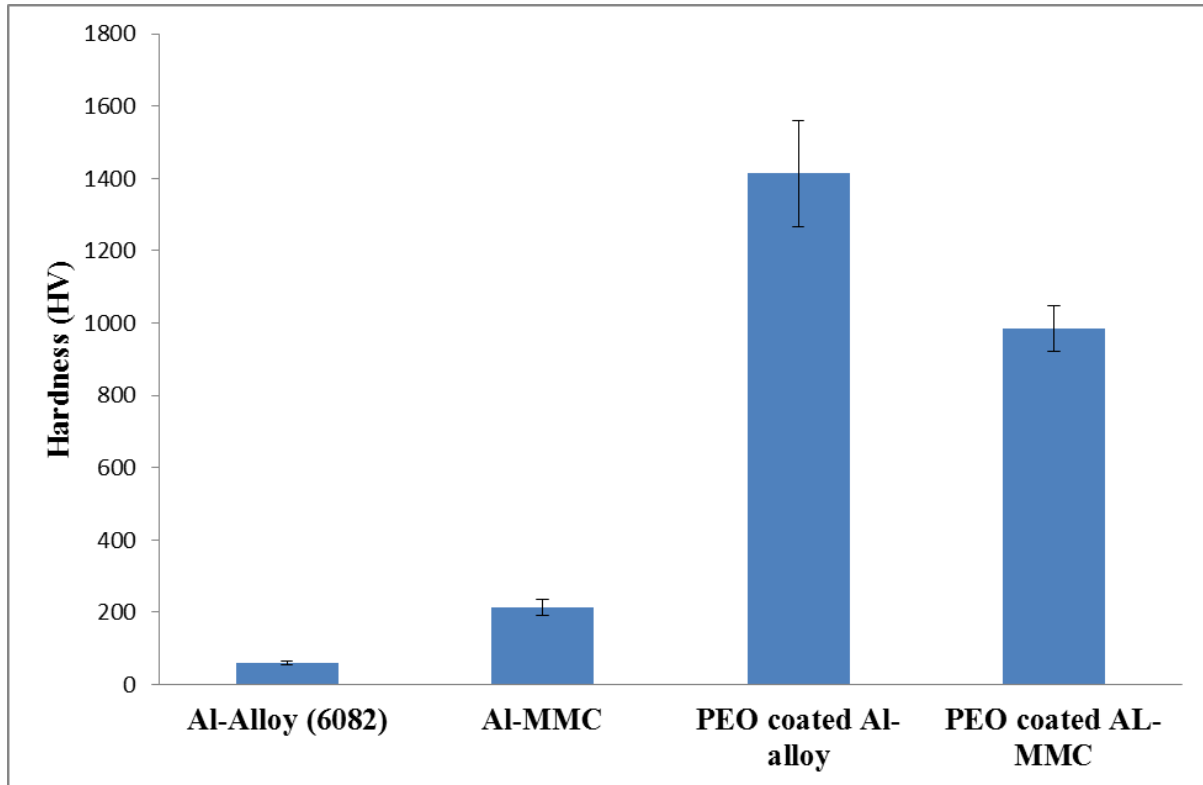

Figure 14: Micro-indentation hardness tests of the different disc materials (error bar shows standard deviation of 4 measured values)

4. Conclusions

The coefficients of friction associated with the alumina coated brake rotors were monitored throughout the dynamometer tests and were seen to be in the region of 0.28-0.34 which is acceptable for modern brake friction pair formulations. The coated aluminium alloy rotor showed substantial resistance to elevated temperatures and was able to withstand rubbing surface temperatures of over 500 °C without any damage to the substrate. The plain (uncoated) aluminium alloy and Al-MMC rotors could not withstand such conditions. However, the coated Al-MMC rotor suffered a significant reduction in COF at elevated temperature which limited the maximum surface temperature reached to less than 500°C.

The PEO coating on the aluminium alloy substrate achieved a micro hardness of 1400 HV while the hardness of the same coating on the Al-MMC was 980 HV. SEM micrographs indicated that the PEO coatings were denser and more uniform on the Al-alloy substrate than on the Al-MMC which substantiates why they gave higher hardness values. The coating thickness for the Al-MMC considerably reduced during dynamometer testing but that on the coated Al alloy stayed approximately constant at about 50 μm . It was also demonstrated that a transfer layer from the brake pads to the rubbing surface existed for both coated rotors and the thickness of that layer was in the range of 2-4 μm .

The coated aluminium alloy disc brake rotor eventually failed when the surface temperature exceeded about 550°C. The catastrophic failure of the coated disc was believed to be due to a combination of high mechanical and thermal stress in a region at the inner circumference of the rubbing surface where temperatures are also very high. Intergranular failure occurred at the grain boundaries of the wrought billet from which the disc brake rotor was machined. It may be possible to achieve further performance robustness by metallurgical changes to the aluminium alloy substrate and/or optimisation of the rotor geometry to enhance cooling including the use of ventilated discs.

5. Acknowledgement

The authors would like to thank the Kuwaiti National Government for funding Dr. Alnaqi's scholarship and Dirk Welp of TMD Friction Services for supplying the brake pad materials.

References

- [1] European Federation for Transport and Environment AISBL. 2012 [Accessed December 2012]; Available from: <http://www.transportenvironment.org/>.
- [2] M. A. Alsaif, K. L. Dahm, S. Shrestha, P. A. Dearnley, and D. C. Barton, *Plasma Electrolytic Oxidation (PEO) treated aluminium metal matrix composite rotors for lightweight automotive brakes*, France, 2010.
- [3] P. J. Blau and H. M. Meyer, "Characteristics of wear particles produced during friction tests of conventional and unconventional disc brake materials," *Wear*, vol. 255, pp. 1261-1269, 2003.
- [4] K. L. Dahm, A. J. Black, S. Shrestha, and P. A. Dearnley, "Plasma Electrolytic Oxidation treatment of aluminium alloys for lightweight disc brake rotors," *IMEchE Conference on Braking*, York (UK), pp. 53-60, 2009.
- [5] D. G. Grieve, D. C. Barton, D. A. Crolla, and J. T. Buckingham, "Design of a lightweight automotive brake disc using finite element and Taguchi techniques," *Proceedings of the Institution of Mechanical Engineers. Part D: Journal of Automobile Engineering*, vol. 212(4), pp. 245-254, 1997.

- [6] W. Bensalah, K. Elleuch, M. Feki, M. DePetris-Wery, H.F. Ayedi, "Comparative study of mechanical and tribological properties of alumina coatings formed on aluminium in various conditions," *Materials and Design*, vol. 30 (2009) 3731–3737.
- [7] G. Bolelli, L. Lusvarghi, M. Barletta, "Wear behaviour of thermally sprayed ceramic oxide coatings", *Wear* 267 (2009) 944–953.
- [8] J. A. Curran and T. W. Clyne, "The thermal conductivity of plasma electrolytic oxide coatings on aluminium and magnesium," *Surface & Coatings Technology*, vol. 199, pp. 177-183, 2005.
- [9] S. H. Cui, J. M. Han, Y. P. Du, and W. J. Li, "Corrosion resistance and wear resistance of plasma electrolytic oxidation coatings on metal matrix composites," *Surface & Coatings Technology*, vol. 201, pp. 5306-5309, 2007.
- [10] U. Malayoglu, K. C. Tekin, U. Malayoglu, and S. Shrestha, "An investigation into the mechanical and tribological properties of plasma electrolytic oxidation and hard-anodized coatings on 6082 aluminum alloy," *Materials Science and Engineering a-Structural Materials Properties Microstructure and Processing*, vol. 528, pp. 7451-7460, 2011.
- [11] A. L. Yerokhin, X. Nie, A. Leyland, A. Matthews, and S. J. Dowey, "Plasma electrolysis for surface engineering," *Surface & Coatings Technology*, vol. 122, pp. 73-93, 1999.
- [12] W.-C. Gu, G.-H. Lv, H. Chen, G.-L. Chen, W.-R. Feng, and S.-Z. Yang, "Characterisation of ceramic coatings produced by plasma electrolytic oxidation of aluminum alloy," *Materials Science and Engineering a-Structural Materials Properties Microstructure and Processing*, vol. 447, pp. 158-162, 2007.
- [13] S. Cui, J. Han, W. Li, S.-B. Kang, and J.-M. Lee, "Study on wear behavior of plasma electrolytic oxidation coatings on aluminum alloy," *Rare Metals*, vol. 25, pp. 141-145, 2006.
- [14] H. Kalkanci and S. C. Kurnaz, "The effect of process parameters on mullite-based plasma electrolytic oxide coatings," *Surface & Coatings Technology*, vol. 203, pp. 15-22, 2008.
- [15] J. A. Curran, H. Kalkanci, Y. Magurova, and T. W. Clyne, "Mullite-rich plasma electrolytic oxide coatings for thermal barrier applications," *Surface & Coatings Technology*, vol. 201, pp. 8683-8687, 2007.
- [16] A. Alnaqi, S. Shrestha, P. Brooks, and D. Barton, "Thermal Performance of PEO Coated Lightweight Brake Rotors Compared with Grey Cast Iron," *Eurobrake 2014 conference*, France, 2014.
- [17] A. Alnaqi, "Characterisation of coated lightweight brake rotors," PhD thesis, Mechanical Engineering, University of Leeds, Leeds, 2014.
- [18] A. Alnaqi, D. Barton, and P. Brooks, "Reduced scale thermal characterization of automotive disc brake," *Submitted for publication in : Applied thermal engineering*, vol., 2014.
- [19] A. Alnaqi, D. Barton, and P. Brooks, *Thermal Performance of Monolithic and Coated Disc Brakes Using Abaqus and Matlab Software*, Vienna, Austria, SIMULIA Community Conference, 2013.
- [20] M. Warmuzek, "Metallographic Techniques for Aluminum and Its Alloys," In *Metallography and Microstructures*, ASM Handbook, Vander Voort, G.F. (Ed.), vol. 9, pp. 711–751. Materials Park, OH: ASM International. 2004.
- [21] J. A. Curran, "Thermal and Mechanical Properties of Plasma Electrolytic Oxide Coatings," PhD thesis, University of Cambridge, 2005.
- [22] G.-H. Lv, W.-C. Gu, H. Chen, L. Li, E.-W. Niu, and S.-Z. Yang, "Microstructure and corrosion performance of oxide coatings on aluminium by plasma electrolytic oxidation in silicate and phosphate electrolytes," *Chinese Physics Letters*, vol. 23, pp. 3331-3333, 2006.
- [23] S. Shrestha, P. Shashkov, and B. D. Dunn, "MICROSTRUCTURAL AND THERMO-OPTICAL PROPERTIES OF BLACK KERONITE PEO COATING ON ALUMINIUM ALLOY AA7075 FOR SPACECRAFT MATERIALS APPLICATIONS," *10th Symposium on Materials in a Space Environment*, Colliour, France, 2006.

- [24] W. Xue, X. Wu, X. Li, and H. Tian, "Anti-corrosion film on 2024/SiC aluminum matrix composite fabricated by microarc oxidation in silicate electrolyte," *Journal of Alloys and Compounds*, vol. 425, pp. 302-306, 2006.