



UNIVERSITY OF LEEDS

This is a repository copy of *Poorer mental health is associated with cognitive deficits in old age*.

White Rose Research Online URL for this paper:
<http://eprints.whiterose.ac.uk/84476/>

Version: Accepted Version

Article:

Bauermeister, S and Bunce, D (2015) Poorer mental health is associated with cognitive deficits in old age. *Aging, Neuropsychology, and Cognition*, 22 (1). 95 - 105. ISSN 1382-5585

<https://doi.org/10.1080/13825585.2014.893554>

Reuse

Unless indicated otherwise, fulltext items are protected by copyright with all rights reserved. The copyright exception in section 29 of the Copyright, Designs and Patents Act 1988 allows the making of a single copy solely for the purpose of non-commercial research or private study within the limits of fair dealing. The publisher or other rights-holder may allow further reproduction and re-use of this version - refer to the White Rose Research Online record for this item. Where records identify the publisher as the copyright holder, users can verify any specific terms of use on the publisher's website.

Takedown

If you consider content in White Rose Research Online to be in breach of UK law, please notify us by emailing eprints@whiterose.ac.uk including the URL of the record and the reason for the withdrawal request.



eprints@whiterose.ac.uk
<https://eprints.whiterose.ac.uk/>

Journal of Aging, Neuropsychology, and Cognition (in press)

Poorer mental health is associated with cognitive deficits in old age

Sarah Bauermeister and David Bunce

Institute of Psychological Sciences, Faculty of Medicine and Health, University of Leeds,
Leeds, LS2 9JT, UK

Address for correspondence: Sarah Bauermeister, Institute of Psychological Sciences,
Faculty of Medicine and Health, University of Leeds, Leeds, LS2 9JT, UK

Email: s.bauermeister@leeds.ac.uk

Abstract word count = 135

Manuscript word count = 5021

Abstract

Few studies have examined the association between within-person (WP) reaction time (RT) variability and mental health (depression, anxiety, social dysphoria) in old age. Therefore, we investigated mental health (using the General Health Questionnaire) and cognitive function (mean RT or WP variability) in 257 healthy, community-dwelling adults aged 50 to 90 years ($M = 63.60$). The cognitive domains assessed were psychomotor performance, executive function, visual search and recognition. Structural equation models revealed that for WP variability, but not mean RT, poorer mental health was associated with visual search and immediate recognition deficits in older persons and that these relationships were partially mediated by executive function. The dissociation between mean RT and WP variability provides evidence that the latter measure may be particularly sensitive to the subtle effects of mental health on cognitive function in old age.

Keywords: age, mental health, cognitive function, GHQ, within-person variability

Research suggests that poorer mental health has a deleterious influence on cognitive function in old age (e.g., Bunce, Handley, & Gaines, 2008a; Bunce, Tzur, Ramchurn, Gain, & Bond, 2008b; Elderkin-Thompson, Mintz, Haroon, Lavretsky, & Kumar, 2007; Sheline et al., 2006). This may arise because depression and anxiety are associated with a reduction in the ability to process information and attentional resources are directed toward intrusive depression or anxiety-related thoughts resulting in impaired cognitive function (Hartlage, Alloy, Vazquez, & Dykman, 1993). With age-related decreases in processing resources, the additional demands created by poor mental health may further reduce the capacity available for cognitive processing. A key cognitive mechanism that may mediate the relationship between mental health and wider cognition is executive control supported by the frontal cortex. Both cognitive (e.g., Eysenck & Calvo, 1992) and neurobiological (e.g., Harrison, 2002) accounts implicate either executive function or the frontal cortex in behavioral responses to stress or anxiety.

In the present study, we assessed whether mental health moderated the association between age and cognition, and given the role of the frontal cortex in both depression (Koenigs & Grafman, 2009) and age-related cognitive decline (R. L. West, 1996), examined if associations were mediated by executive function. We were particularly interested in within-person (WP) RT variability (trial-to-trial variation in RT performance) as the measure is thought to reflect fluctuations in executive function (Bunce, MacDonald, & Hultsch, 2004; R. West, Murphy, Armilio, Craik, & Stuss, 2002) and our previous work (Bunce et al., 2008a; Bunce et al., 2008b) suggests it is sensitive to the effects of mental health on age differences in cognition. More broadly, the measure is held to index neurobiological disturbance (Hultsch, Strauss, Hunter, &

MacDonald, 2008) and is predictive of a range of neurological disorders relating to age including mild cognitive impairment and mild dementia (Bielak, Hultsch, Strauss, Macdonald, & Hunter, 2010; Dixon et al., 2007; Hultsch, MacDonald, Hunter, Levy-Bencheton, & Strauss, 2000), Parkinson's disease (de Frias, Dixon, Fisher, & Camicioli, 2007) and, indeed, mortality (Batterham, Bunce, MacKinnon, & Christensen, in press; MacDonald, Hultsch, & Dixon, 2008).

Therefore, following the findings of our previous studies (Bunce et al., 2008a, 2008b), we expected that WP variability would be greater in older persons with poorer mental health and that this association would be mediated by executive control, particularly those elements emphasizing inhibitory control as implicated by frontal accounts of mental health-cognitive effects (e.g., Hartlage et al., 1993). Given our expectation that mental health effects are mediated by inhibitory mechanisms, unlike our previous studies that used broadly defined measures of executive function (following Miyake Friedman, Emerson, Witzki, Howerter & Wager, 2000, involving updating, switching and inhibition), here we focused on inhibitory control as to our knowledge, no previous work has directly assessed this component in relation to age, mental health and cognition. This focus on inhibitory failures is supported by work elsewhere (e.g., Berman et al., 2011; Joormann, Nee, Berman, Jonides, & Gotlib, 2010) suggesting that performance on cognitive tasks may be affected by task-unrelated distractions such as ruminating and brooding, a source of interference that is more marked in persons diagnosed with major depressive disorders relative to controls.

Additionally, we contrasted WP variability with measures of mean RT obtained from the same cognitive task as our earlier studies showed the two measures to dissociate. That

is, Age x Mental health effects in relation to cognition were found for WP variability but not for mean RT measures suggesting the former measure may be more sensitive to subtle mental health effects. Importantly, whereas our earlier work examined the entire adult lifespan (18 to 92 years), here, we investigated middle age (50 years) to late old age (90 years). Our reasoning here was twofold. First, in the previous work, it is possible that the associations found between age, mental health and cognition were due to the wide age ranges investigated (i.e., spanning the extremes of the adult lifespan). Second, given accounts of inhibitory failure underlying broader cognitive deficits in aging persons (e.g., Hasher & Zacks, 1988), we expected that those inhibitory failures and their association with mental health may be more marked in person aged 50 years and over.

Method

Participants

Two hundred and fifty seven (154 women) community-dwelling persons aged 50 to 90 years ($M = 63.60$, $SD = 7.82$) recruited from local health clubs, sport clubs, community groups and the general community, participated in the study. Exclusions included any self-reports of major neurological disorder or, in order to remove possibly demented persons from the sample, a score <25 on the Mini-Mental State Examination (Folstein, Folstein, & McHugh, 1975). Verbal intelligence was assessed using the National Adult Reading Test (NART: Nelson, 1982; $M = 120.33$, $SD = 7.39$). The study received ethical approval from the appropriate local Research Ethics Committee.

Mental Health

The 12-item version of the General Health Questionnaire (GHQ) assessing depression, anxiety and social dysphoria was used to measure mental health (Goldberg, 1978). Questions (e.g., “been able to concentrate on whatever you’re doing?”, “felt capable of making decisions about things?”, “been thinking of yourself as a worthless person?”) were scored using the Likert method where each item was scored 0 (not at all) to 3 (much more than usual). We report the scale mean in which higher scores indicated poorer mental health ($M = 9.82$; $SD = 4.38$). A Cronbach alpha ($\alpha = .87$) suggested that the internal consistency for this scale was good.

Cognitive Tasks

RTs were collected for a battery of tasks covering the psychomotor, executive function, visual search and recognition domains using E-Prime (Psychology Software Tools, 2002). Instructions emphasised speed and accuracy of responding. Trials were presented pseudorandomly and practice trials were administered for each task.

Psychomotor: Three 48-trial tasks were administered. In a *Simple RT* task (SRT), participants were required to press the space bar whenever an ‘X’ appeared in the center of a computer screen (inter-trial intervals 300-1,000 ms). For a *Two-Choice* (2-CRT) version of the task, participants responded to a black 25 mm diameter circle presented to the right or left of the screen using designated keyboard keys (inter-trial interval = 500 ms). In a *Four-Choice* (4-CRT) version, black circles appeared in any of the four corners of the screen and appropriate keyboard keys used to respond (inter-trial interval = 500 ms).

Executive function: Tasks were administered that emphasised inhibitory control. First, in a 64-trial version of the Eriksen *flanker* task (Eriksen & Schultz, 1979), participants responded to the horizontal direction of a central target arrow while ignoring distractor flanker arrows (2 either side of the target arrow) using designated keyboard keys. Half of the trials were congruent (all arrows in same direction) and half were incongruent (middle arrow opposed direction of flanker arrows), and inter-trial intervals varied between 300 and 1,000 ms. Second, a 100-trial spatial *Stroop arrow* task involved responding to the direction of an arrow presented to the left, right or centre of the screen. 40 trials were spatially congruent (arrow pointed in the same direction as its spatial position on the screen), 40 trials were incongruent (arrow pointed in the opposite direction to its spatial position) and 20 trials were neutral (arrow appeared centrally, pointing left or right). Left or Right keyboard keys were used to respond (inter-trial interval = 500 ms). Finally, in a 96-trial *Stroop word* task, participants responded to the presented word ink color (red, blue, yellow and green) while ignoring the written word (red, blue, yellow and green) using appropriately colored keys. Half the trials were congruent (word-color match) and half were incongruent (word-color not matched), and the inter-trial interval was 500ms. For the above tasks, data from incongruent trials were used in statistical analyses.

Visual search: In a 64-trial *simple visual search* task, a 6 x 6 array of green letter 'O's appeared for each trial. For half of the trials, a green target letter 'Q' was embedded randomly within the array. Designated keyboard keys were pressed to indicate the presence or absence of the Q (inter-trial interval = 500 ms). In a *complex* version of the task, a similar block was presented except stimuli consisted of both green and red letter 'O's and 'Q's. Here, targets were determined by the conjunction of both letter type and

color with responses indicating whether the conjunction was present (e.g., a red 'Q' in an array of green 'Q's, and red and green 'O's), or absent. The inter-trial interval was 500 ms. Responses from target and non-target trials were combined in statistical analyses in both versions of the task.

Recognition: In *immediate recognition*, 16 target concrete nouns were presented for 2 s each in random order (inter-word interval = 500ms). After approximately 1 minute, the 16 target nouns were presented with 16 randomly intermixed distractor nouns. Participants were required to respond "yes" for a target or "no" for a distractor with appropriate keyboard keys. After approximate 30 minutes, a *delayed* test of recognition was administered. RTs for hits and correct rejections were combined for statistical analyses in both versions of the task.

Procedure

Participants completed the GHQ, cognitive tasks, and aerobic fitness measures for another part of the wider study (not reported here) were also recorded¹. The testing session lasted approximately 90 minutes.

Data processing and statistical analysis

Unusually fast and slow trials were eliminated using a lower boundary of 150ms and an upper boundary of the individual mean RT + 3 SD. Missing data points were replaced with the individual mean RT. For correct trials only, we computed mean RT and WP variability measures, the latter using the intraindividual standard deviation (ISD)

¹ We reran the main analyses reported below where significant effects were found having adjusted for aerobic fitness, **all the significant effects remained, and no others became significant.**

following procedures described elsewhere (Hultsch, MacDonald, & Dixon, 2002). At the sample level, we replaced a small amount of missing data ($\leq 1.6\%$) using the EM algorithm in SPSS version 18 (IBM Corporation, 2009) taking into account all of the variables in the study (see Shafer & Graham, 2002). To test moderation effects, the age and GHQ variables were centred, and the Age x GHQ cross-product interaction term computed.

Structural equation modelling using Amos version 18 (Amos Development Corporation, 2009) established whether the Age x GHQ interaction term (that was expected to show that older persons of poorer mental health recorded lower cognitive performance) first, predicted the cognitive outcomes and second, was mediated by executive function using a three stage procedure for testing mediated moderation following Baron and Kenny (1986). In Model 1 (see Figure 1 for Models 1 to 3), age, GHQ and the Age x GHQ interaction term formed the exogenous variables and latent constructs for psychomotor performance, executive function, visual search, and recognition represented the endogenous variables. This model established whether the Age x GHQ interaction paths attained significance having taken into account the primary effects of age and GHQ. In Model 2, all of the paths from the exogenous to the endogenous variables were eliminated except for those to executive function. Additional paths were introduced from executive function to the psychomotor, visual search and recognition endogenous variables. The focus here was whether the Age x GHQ path to executive function, and also the paths between executive function and the endogenous variables, became significant. Model 3 developed the previous model by reintroducing the direct paths between age, GHQ and the Age x GHQ variables, and the latent constructs while retaining the paths to and from executive function. In this model, if Age x GHQ

interaction terms that were significant in Model 1 became nonsignificant, it would suggest that mediation had taken place via executive function. Statistics for the three models are presented in Table 1.

Results

Bivariate correlations (not shown) between age and the cognitive variables were all significant with older age associated with slower responding and greater WP variability. Correlations involving the GHQ were predominantly nonsignificant. As NART scores were significantly associated with several of the cognitive variables, we adjusted for this variable in all analyses.

The findings for the three models for mean RT and WP variability are presented in Table 1. Covariances between error terms for SRT and 4-CRT, and between Stroop word and complex visual search, were allowed to facilitate model fit (Kline, 2005). In Model 1, although chi-square for both mean RT and WP variability was significant, the other goodness-of-fit statistics suggested acceptable model fit (see Table 1). Older age was associated with both slower mean RT and greater WP variability with paths to all the latent variables significant. Importantly, there were also significant Age x GHQ interactions in relation to both visual search and recognition for WP variability. Figure 2, obtained through multiple regression, shows the interaction in relation to visual search, suggesting that older age and poorer mental health were associated with greater WP variability (the significant interaction for recognition exhibited a similar trend). For mean RT, none of the Age x GHQ interaction terms were significant. As a major objective of the study was to test whether significant Age x GHQ interactions were mediated by

executive function in Models 2 and 3, we did not consider mean RT further in the mediated moderation analyses.

In Model 2 for WP variability, goodness-of-fit statistics suggested acceptable model fit. Both older age and higher GHQ scores were associated with greater WP variability in executive function, and executive function, in turn, was associated with greater WP variability in psychomotor performance, visual search and recognition. However, the Age x GHQ path to executive function was nonsignificant, thereby failing to meet one of the criteria for mediation (Baron & Kenny, 1986). Model 3 combined Models 1 and 2 with the original direct paths reintroduced from age, GHQ and the Age x GHQ interaction term to psychomotor performance, visual search and recognition. Again, goodness-of-fit statistics suggested acceptable model fit. Notably, the significant Age x GHQ paths for visual search and recognition in Model 1 were rendered nonsignificant in this model having taken into account executive function. Unexpectedly in Model 3, the Age x GHQ to Psychomotor performance path became significant having been nonsignificant in Model 1. This appears to be a suppressor effect resulting from the introduction of additional paths in Model 3.

In sum, although the full requirements for mediated moderation were not met as the Age x GHQ to executive function path in Model 2 was nonsignificant, the findings for Model 3 suggest that executive function was having an influence on associations between age, mental health and the other cognitive variables (i.e., the originally significant Age x GHQ paths to visual search and recognition became nonsignificant).

Discussion

There were several notable findings from the current investigation. First, as with studies elsewhere (e.g., Bunce et al., 2008a; Elderkin-Thompson et al., 2007; Sheline et al., 2006; R. L. West, 1996), we found that poorer mental health was associated with cognitive deficits in older persons and that, here, the association was greater with increasing old age. Second, this association was identified in respect to WP variability but not measures of mean RT from the same task. Third, we obtained qualified evidence that the significant Age x GHQ interactions in relation to the other cognitive variables were mediated by executive function.

The present study confirmed that for community-dwelling individuals aged 50 to 90 years screened for major neurological disorders and recording MMSE scores >24, poorer mental health was associated with cognitive deficits, and this trend grew stronger with increasing age. Importantly, the study found the association in relation to measures of WP variability but not measures of mean RT obtained from the same cognitive task. This finding adds to evidence that relative to mean RT, measures of WP variability are sensitive to subtle effects associated with mild psychopathology (Bunce et al., 2008a; Bunce et al., 2008b). Similar differential effects have also been found in relation to mild cognitive impairment (Dixon et al., 2007) and microscopic white matter lesions in the frontal cortex (Bunce et al., 2010; Bunce et al., 2007). Together, this work suggests that measures of WP variability may have considerable potential as part of wider assessment batteries in clinical contexts.

Unlike our earlier work (Bunce et al., 2008a; Bunce et al., 2008b), we only obtained partial support for the possibility that age-mental health-cognition effects were mediated by executive function. There are two possible explanations for this finding.

First, many of our participants were recruited from fitness clubs and it is thus possible that the sample was healthier and of greater fitness than is common in investigations of these older age ranges. Indeed, relative to our earlier study using the GHQ (Bunce et al., 2008b), the present sample recorded significantly better ($p < .01$) mental health scores. Although significant Age x GHQ interactions were found in relation to two of the four latent variables (visual search and recognition), it may require more marked mental health deficits to reveal associations with a broader range of cognitive variables, including psychomotor skills and executive function. Second, given relations with inhibitory function implied by frontal accounts of mental health-cognitive effects (Hartlage et al., 1993), we focused our executive control measures on inhibition. It is possible that this focus was too narrow as in Miyake's original formulation (Miyake et al., 2000), the constructs of updating and switching were taken into account too. It is likely that a combination of better mental health in this sample and the narrow focus of the executive function measures, underpinned the weakened mediated-moderation effects. Clearly, further research is required to provide insights into the antecedents and mechanisms influencing mental health-cognition relations in old age.

Although the study possessed several strengths including a comprehensive battery of cognitive measures and the use of sophisticated statistical modelling procedures, there were some limitations we should acknowledge. First, the design was cross-sectional and despite the use of structural equation modelling, we cannot therefore infer causality. Second, as is common elsewhere in community-based research, we screened participants using self-report measures of neurological disorders rather than specialised assessment commonly used in clinic-based research. Additionally, although not a limitation, in Model 3 for ISDs, we obtained a path coefficient for executive

function and psychomotor performance of 1.05. In structural equation modelling, it is possible that a standardised path coefficient is >1 , normally occurring when variables share a high degree of multicollinearity (Jöreskog, 1999; Kline, 2005). In studies such as the present where multiple variables were operationalized using similar metrics, multicollinearity is always a potential issue. However, we believe through the adoption of rigorous modelling procedures, we have offset the potential difficulties from this source. Finally, we used a relatively short 12-item self-report measure of mental health developed to assess minor psychiatric disorders, and it is possible that this measure did not sufficiently capture the construct of interest. However, research (e.g., Werneke, Goldberg, Yalcin, & Ustun, 2000) shows this version of the GHQ to tap constructs relating to depression, social dysfunction, and loss of confidence, and associations of 0.54 and above have been reported with the Beck Depression Inventory in both outpatient (Gao et al., 2004) and community samples (Bond & Bunce, 2000). We are, therefore, confident that the measure is sufficiently sensitive to capture state variation in minor psychiatric disorders.

Practically, the present study provides further evidence that the effects of poor mental health on cognition are selective and subtle, and can have greater impact with increasing age. Moreover, the findings suggest that measures of WP variability may have considerable potential as supplements to existing neuropsychological assessment tools in clinical settings. Earlier research has shown the measure to predict age-related neurological disorders including mild cognitive impairment and mild dementia (Bielak et al., 2010; Dixon et al., 2007), and Parkinson's disease (de Frias et al., 2007), and the present findings suggests this extends to mental health constructs such as depression, anxiety and stress. Clearly, further research is required to confirm this clinical potential.

To conclude, the findings suggest that in cognitively intact older individuals functioning in the community, mental health may have a subtle effect on cognitive performance. We found that that GHQ scores moderated the association between age and cognition, and that executive control partially accounted for that association, although the full requirements for mediation were not met. Importantly, the above associations were apparent for measures of WP variability but not for mean RT obtained for the same cognitive tasks. The finding provides further evidence that WP variability measures may be particularly sensitive to subtle cognitive effects and may have considerable potential for use in both community and clinical settings.

References

- Baron, R. M., & Kenny, D. A. (1986). The moderator-mediator variable distinction in social psychological research: Conceptual, strategic, and statistical considerations. *Journal of Personality and Social Psychology*, *51*, 1173-1182.
- Batterham, P. J., Bunce, D., MacKinnon, A. J., & Christensen, H. (in press). Intraindividual reaction time variability and all-cause mortality over 17 years. *Age and Ageing*.
- Berman, M. G., Peltier, S., Nee, D. E., Kross, E., Deldin, P. J., & Jonides, J. (2011). Depression, rumination and the default network. *Soc Cogn Affect Neurosci*, *6*(5), 548-555. doi: 10.1093/scan/nsq080
- Bielak, A. A., Hultsch, D. F., Strauss, E., Macdonald, S. W., & Hunter, M. A. (2010). Intraindividual variability in reaction time predicts cognitive outcomes 5 years later. *Neuropsychology*, *24*(6), 731-741. doi: 10.1037/a0019802
- Bond, F. W., & Bunce, D. (2000). Mediators of change in emotion-focused and problem-focused worksite stress management interventions. *J Occup Health Psychol*, *5*(1), 156-163.

- Bunce, D., Anstey, K. J., Cherbuin, N., Burns, R., Christensen, H., Wen, W., & Sachdev, P. S. (2010). Cognitive deficits are associated with frontal and temporal lobe white matter lesions in middle-aged adults living in the community. *PLoS One*, *5*(10), e13567. doi: 10.1371/journal.pone.0013567
- Bunce, D., Anstey, K. J., Christensen, H., Dear, K., Wen, W., & Sachdev, P. (2007). White matter hyperintensities and within-person variability in community-dwelling adults aged 60-64 years. *Neuropsychologia*, *45*(9), 2009-2015.
- Bunce, D., Handley, R., & Gaines, S. O., Jr. (2008a). Depression, anxiety, and within-person variability in adults aged 18 to 85 years. *Psychol Aging*, *23*(4), 848-858.
- Bunce, D., MacDonald, S. W., & Hultsch, D. F. (2004). Inconsistency in serial choice decision and motor reaction times dissociate in younger and older adults. *Brain Cogn*, *56*(3), 320-327.
- Bunce, D., Tzur, M., Ramchurn, A., Gain, F., & Bond, F. W. (2008b). Mental health and cognitive function in adults aged 18 to 92 years. *Journal of Gerontological Sciences: Psychological Sciences* *63*(2), 67-74.
- de Frias, C. M., Dixon, R. A., Fisher, N., & Camicioli, R. (2007). Intraindividual variability in neurocognitive speed: a comparison of Parkinson's disease and normal older adults. *Neuropsychologia*, *45*(11), 2499-2507.
- Dixon, R. A., Garrett, D. D., Lentz, T. L., MacDonald, S. W., Strauss, E., & Hultsch, D. F. (2007). Neurocognitive markers of cognitive impairment: exploring the roles of speed and inconsistency. *Neuropsychology*, *21*(3), 381-399. doi: 10.1037/0894-4105.21.3.381
- Elderkin-Thompson, V., Mintz, J., Haroon, E., Lavretsky, H., & Kumar, A. (2007). Executive dysfunction and memory in older patients with major and minor depression. *Archives of Clinical Neuropsychology*, *22*, 221-270.
- Eriksen, C. W., & Schultz, D. W. (1979). Information processing in visual search: A continuous flow conception and experimental results. *Perception & Psychophysics*, *25*(4), 249-263.

- Eysenck, M. W., & Calvo, M. G. (1992). Anxiety and performance: the processing efficiency theory. *Cognition and Emotion*, 6, 409-434.
- Folstein, M. F., Folstein, S. E., & McHugh, P. R. (1975). "Mini-mental-state": A practical method for grading the cognitive state of patients for the clinician. *Journal of Psychiatric Research*, 12, 189-198.
- Gao, F., Luo, N., Thumboo, J., Fones, C., Li, S. C., & Cheung, Y. B. (2004). Does the 12-item General Health Questionnaire contain multiple factors and do we need them? [Evaluation Studies]. *Health Qual Life Outcomes*, 2, 63. doi: 10.1186/1477-7525-2-63
- Goldberg, D. (1978). *Manual of the general health questionnaire*. Windsor Ontario, Canada: National Foundation for Educational Research.
- Harrison, P. J. (2002). The neuropathology of primary mood disorder. *Brain*, 125, 1428-1449.
- Hartlage, S., Alloy, L. B., Vazquez, C., & Dykman, B. (1993). Automatic and effortful processing in depression. *Psychological Medicine*, 27, 247-278.
- Hasher, L., & Zacks, R. T. (1988). Working memory, comprehension and aging: A review and new view. In G. H. Bower (Ed.), *The psychology of learning and motivation* (Vol. 22, pp. 193-225). San Diego, CA: Academic Press.
- Hultsch, D. F., MacDonald, S. W., & Dixon, R. A. (2002). Variability in reaction time performance of younger and older adults. *Journal of Gerontological Sciences: Psychological Sciences* 57(2), 101-115.
- Hultsch, D. F., MacDonald, S. W. S., Hunter, M. A., Levy-Bencheton, J., & Strauss, E. (2000). Intraindividual variability in cognitive performance in older adults: comparison of adults with mild dementia, adults with arthritis, and healthy adults. *Neuropsychology*, 14(4), 588-598.
- Hultsch, D. F., Strauss, E., Hunter, M. A., & MacDonald, S. W. S. (2008). Intraindividual Variability, Cognition and Aging. In F. I. M. Craik & T. A. Salthouse (Eds.), *The*

Handbook of Aging and Cognition (3 ed., pp. 491-556). New York and Hove: Psychology Press.

Joormann, J., Nee, D. E., Berman, M. G., Jonides, J., & Gotlib, I. H. (2010). Interference resolution in major depression. *Cogn Affect Behav Neurosci*, *10*(1), 21-33. doi: 10.3758/CABN.10.1.21

Jöreskog, K. G. (1999). How Large Can a Standardized Coefficient Be? Retrieved 17/11/11, from <http://www.ssicentral.com/lisrel/techdocs/HowLargeCanaStandardizedCoefficientbe.pdf>

Kline, R. B. (2005). *Principles and Practice of Structural Equation Modeling* (2nd ed.). United States of America: The Guildford Press.

Koenigs, M., & Grafman, J. (2009). The functional neuroanatomy of depression: distinct roles for ventromedial and dorsolateral prefrontal cortex. *Behav Brain Res*, *201*(2), 239-243. doi: 10.1016/j.bbr.2009.03.004

MacDonald, S. W. S., Hultsch, D. F., & Dixon, R. A. (2008). Predicting impending death: inconsistency in speed is a selective and early marker. *Psychol Aging*, *23*(3), 595-607.

Miyake, A., Friedman, N. P., Emerson, M. J., Witzki, A. H., Howerter, A., & Wager, T. D. (2000). The unity and diversity of executive functions and their contributions to complex "Frontal Lobe" tasks: a latent variable analysis. *Cogn Psychol*, *41*(1), 49-100. doi: 10.1006/cogp.1999.0734

Nelson, H. (1982). *The National Adult Reading Test (NART)*. Windsor, England: Nfer-Nelson.

Shafer, J. L., & Graham, J. W. (2002). Missing data: Our view of the state of the art. *Psychol Methods*, *7*, 147-177.

Sheline, Y. I., Barch, D. M., Garcia, K., Gersing, K., Pieper, C., Welsh-Bohmer, K., . . . Doraiswamy, P. M. (2006). Cognitive function in late life depression:

Relationships to depression severity, cerebrovascular risk factors and processing speed. *Biological Psychology*, 60, 58-65.

Werneke, U., Goldberg, D. P., Yalcin, I., & Ustun, B. T. (2000). The stability of the factor structure of the General Health Questionnaire. *Psychol Med*, 30(4), 823-829.

West, R., Murphy, K. J., Armilio, M. L., Craik, F. I., & Stuss, D. T. (2002). Lapses of intention and performance variability reveal age-related increases in fluctuations of executive control. *Brain Cogn*, 49(3), 402-419.

West, R. L. (1996). An application of prefrontal cortex function theory to cognitive aging. *Psychol Bull*, 120(2), 272-292.

Table 1. Models 1-3 goodness-of-fit measures and standardized regression weights for mental health (GHQ) for both mean reaction time and within-person variability

Goodness-of-fit	Mean RT		ISD	
	Model 1	Model 1	Model 2	Model 3
χ^2	73.46*	78.78**	107.61**	78.78**
χ^2/df	1.44	1.55	1.71	1.55
CFI	.98	.96	.93	.96
NFI	.94	.89	.85	.89
RMSEA	.04	.05	.05	.05
Path Coefficients				
Psychomotor	<--Age	.47**	.43**	-.16
Executive Function	<--Age	.68**	.56**	.54**
Visual Search	<--Age	.52**	.32**	.06
Recognition	<--Age	.53**	.36**	.02
Psychomotor	<--GHQ	.04	.18*	.04
Executive Function	<--GHQ	.04	.13	.17**
Visual Search	<--GHQ	.06	.10	.04
Recognition	<--GHQ	.10	.12	.04
Psychomotor	<--Age x GHQ	-.11	-.11	-.18**
Executive Function	<--Age x GHQ	.00	.07	.04
Visual Search	<--Age x GHQ	.09	.15*	.12
Recognition	<--Age x GHQ	.12	.20*	.16
Psychomotor	<--EF		.88**	1.05**
Visual Search	<--EF		.54**	.47**
Recognition	<--EF		.57**	.61**

Notes: χ^2/df = chi-squared/degrees of freedom; CFI = comparative fit index; NFI = non normative fit index; RMSEA = root mean square error of approximation (good fit = χ^2/df = <2.0; CFI and NFI = >.90; RMSEA = <.05); GHQ = General Health Questionnaire; ISD = intraindividual standard deviation; RT = reaction time; EF = executive function. All models adjusted for National Adult Reading Test scores. *p < .05; **p < .01.

Model 1

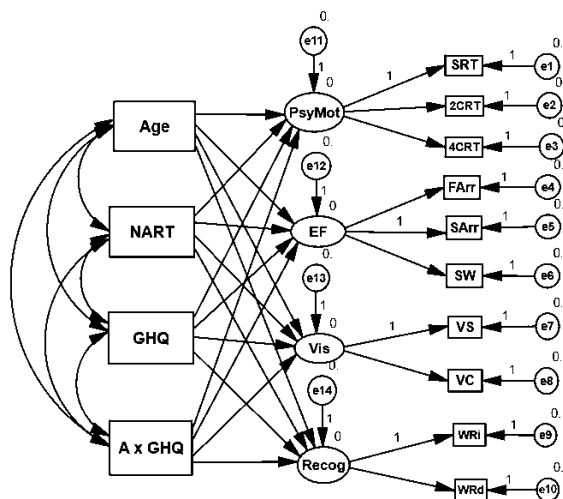

Model 2

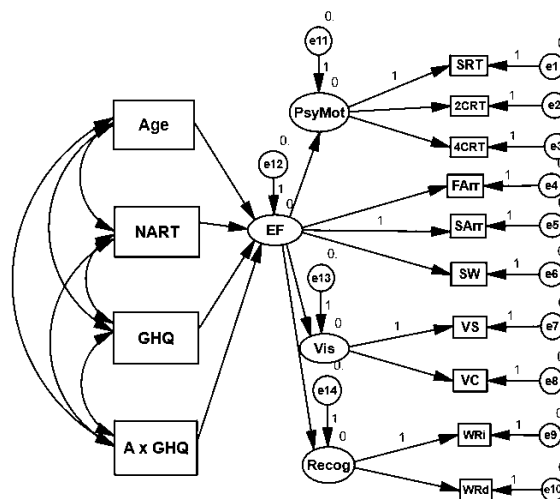

Model 3

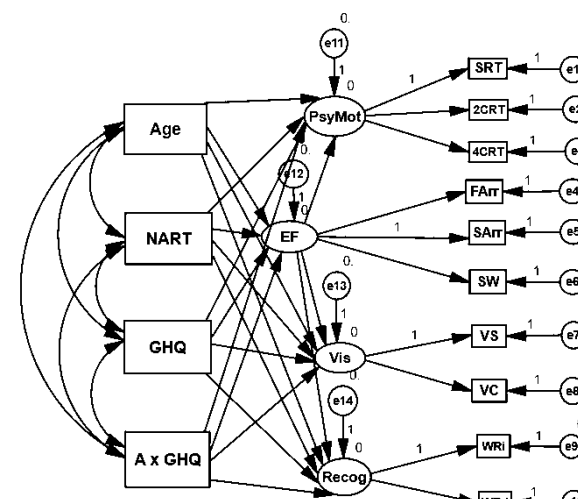

Figure 1. Structural equation models, for age, GHQ, Age x GHQ interaction terms, and cognitive variables.

e1-e14 = error terms 1-14, PsyMot = psychomotor performance, EF = executive function, Vis = visual search, Recog = recognition, SRT = simple reaction time, 2CRT = two-choice reaction time, 4CRT = four-choice reaction time, FArr = flanker arrows, SArr = Stroop arrow, SW = Stroop word, VS = simple visual search, VC = complex visual search, WRi = immediate recognition, WRd = delayed recognition, GHQ = General Health Questionnaire-12, A x GHQ = Age x GHQ interaction term, NART = National Adult Reading Test.

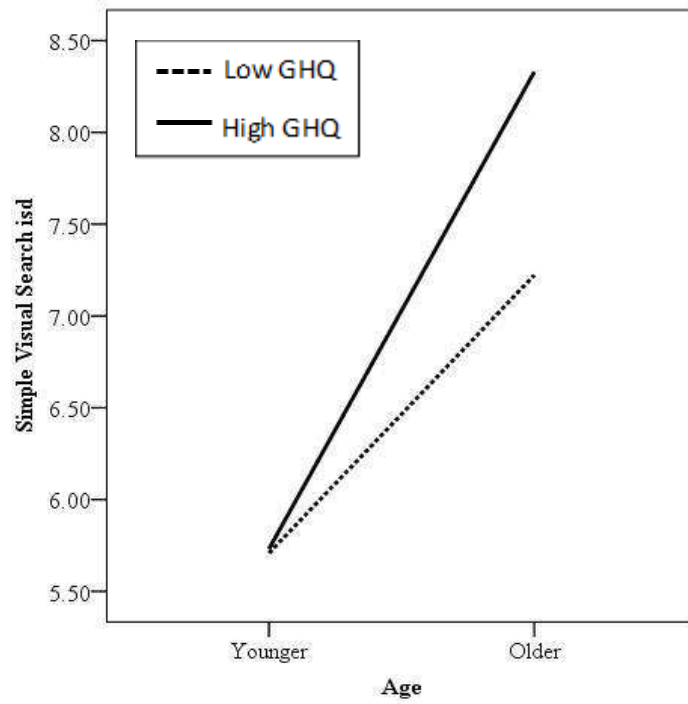

Figure 2. Significant Age x GHQ interaction in respect to WP variability for simple visual search (higher GHQ scores = poorer mental health; age= continuous variable).