



UNIVERSITY OF LEEDS

This is a repository copy of *Modality specificity and integration in working memory: Insights from visuospatial bootstrapping*.

White Rose Research Online URL for this paper:
<http://eprints.whiterose.ac.uk/81571/>

Version: Accepted Version

Article:

Allen, RJ, Havelka, J, Falcon, T et al. (2 more authors) (2014) Modality specificity and integration in working memory: Insights from visuospatial bootstrapping. *Journal of Experimental Psychology: Learning, Memory, and Cognition*. ISSN 1939-1285

<https://doi.org/10.1037/xlm0000058>

Reuse

Unless indicated otherwise, fulltext items are protected by copyright with all rights reserved. The copyright exception in section 29 of the Copyright, Designs and Patents Act 1988 allows the making of a single copy solely for the purpose of non-commercial research or private study within the limits of fair dealing. The publisher or other rights-holder may allow further reproduction and re-use of this version - refer to the White Rose Research Online record for this item. Where records identify the publisher as the copyright holder, users can verify any specific terms of use on the publisher's website.

Takedown

If you consider content in White Rose Research Online to be in breach of UK law, please notify us by emailing eprints@whiterose.ac.uk including the URL of the record and the reason for the withdrawal request.



eprints@whiterose.ac.uk
<https://eprints.whiterose.ac.uk/>

Modality Specificity and Integration in Working Memory: Insights from Visuospatial
Bootstrapping

Richard J. Allen^a, Jelena Havelka^a, Thomas Falcon^a, Sally Evans^a, & Stephen Darling^b

^a - Institute of Psychological Sciences, University of Leeds

^b - Queen Margaret University, Edinburgh

IN PRESS, JEPLMC

Correspondence concerning this article should be addressed to Richard Allen, Institute of Psychological Sciences, University of Leeds, LS2 9JT, United Kingdom. E-mail:

r.allen@leeds.ac.uk

Abstract

The question of how meaningful associations between verbal and spatial information might be utilized to facilitate working memory performance is potentially highly instructive for models of memory function. The present study explored how separable processing capacities within specialized domains might each contribute to this, by examining the disruptive impacts of simple verbal and spatial concurrent tasks on young adults' recall of visually presented digit sequences encountered either in a single location or within a meaningful spatial 'keypad' configuration. The previously observed advantage for recall in the latter condition (the 'visuospatial bootstrapping effect') consistently emerged across three experiments, indicating use of familiar spatial information in boosting verbal memory. The magnitude of this effect interacted with concurrent activity; articulatory suppression during encoding disrupted recall to a greater extent when digits were presented in single locations (Experiment 1), while spatial tapping during encoding had a larger impact on the keypad condition and abolished the visuospatial bootstrapping advantage (Experiment 2). When spatial tapping was performed during recall (Experiment 3), no task by display interaction was observed. Outcomes are discussed within the context of the multicomponent model of working memory, with a particular emphasis on cross-domain storage in the episodic buffer (Baddeley, 2000).

Key words: Working memory, binding, bootstrapping, episodic buffer.

Modality Specificity and Integration in Working Memory: Insights from Visuospatial
Bootstrapping

The majority of research on working memory has examined how information encountered within a single modality (e.g. vision or audition) is temporarily encoded and subsequently recalled. In line with this, classic models of working memory (e.g. Baddeley & Hitch, 1974; Logie, 1995) focused on capturing distinctions between domains or modalities. Baddeley and Hitch (1974) suggested a tripartite model comprising separate auditory-verbal and visuospatial stores (the phonological loop and visuospatial sketchpad respectively) and a central executive control resource. A range of evidence exists to support such distinctions between different temporary storage capacities (Baddeley, 2012), though research suggests the operation of both specialized and general processing resources (e.g. Barrouillet, Bernadin, Portrat, Vergauwe, & Camos, 2007; Cowan & Morey, 2007; Davis, Rane, & Hiscock, 2013; Jarrold, Tam, Baddeley, & Harvey, 2011; Morey & Mall, 2012), with shared variance between domains more pervasive when complex processing is required (Engle, Tuholski, Laughlin, & Conway, 1999; Engle, 2010).

This leaves open the question of how interaction between different sources of information might be achieved in order to provide us with a multi-modal representation of the world. For example, when we encounter verbal stimuli distributed across spatial locations, how might these sources of information be combined in working memory in order to inform and facilitate subsequent retrieval? Baddeley (2000) addressed this in a revised multicomponent model, adding a modality-general store termed the episodic buffer. This was assumed to support the active integration and binding of information from different sources, including modality-specific subsystems and pre-existing knowledge held in long-term memory. Recent evidence has indicated that participants are able to make recognition or recall judgments concerning simple combinations of features within domains (e.g. Allen, Baddeley,

& Hitch, 2006, 2014), between verbal and spatial domains (Langerock, Vergauwe, & Barrouillet, 2014; Morey, 2009), and across modalities (Allen, Hitch, & Baddeley, 2009). It is also possible to observe interactions between domains or modalities that serve to facilitate single task performance. Verbal coding can be enlisted to support visuospatial WM (e.g. Brown, Forbes, & McConnell, 2006; Mate, Allen, & Baques, 2012; Morey & Cowan, 2005), with articulatory suppression often required to prevent the use of such strategies when examining visual and spatial WM. Similarly, visual and spatial WM resources can support verbal memory, either automatically or through strategy adoption. For example, St. Clair-Thompson and Allen (2013) found that a visual strategy (as indexed by effects of visuospatial n-back and dynamic visual noise) could be used during backward digit recall to aid reversal of the sequence at recall. Indeed, there is an established literature indicating visuospatial support for verbal memory (e.g. Brooks, 1967; Paivio, 1991; Ueno & Saito, 2013). However, few studies have examined how verbal and spatial information may be combined using stored long-term knowledge; indeed, the question of how different domains interact with each other and with LTM was a core motivation for the episodic buffer concept (Baddeley, 2000).

The question of how such information may be utilized to boost memory performance has recently been addressed using the *visuospatial bootstrapping* paradigm introduced by Darling and Havelka (2010). In the key conditions of this first study, digit sequences were visually presented either in a single spatial location, or within a familiar keypad array as commonly found on telephones or ATMs. Verbal recall of the digit sequences was significantly more accurate when encountered within the familiar keypad array, relative to the single location condition. This effect appears to be non-strategic in nature, as the affordance is an incidental and implicit part of the task (see Morey, 2011); spatial information is not explicitly required for successful performance, but reliable effects are nevertheless observed. This would fit with a recent version of the multicomponent WM model (Baddeley, Allen, &

Hitch, 2011), which proposes that many forms of information binding (e.g. visual, cross-modal, or within linguistic sequences) can proceed relatively automatically (e.g. Allen et al., 2006, 2014; Allen et al., 2009; Allen, Hitch, Mate, & Baddeley, 2012; Baddeley, Hitch, & Allen, 2009); this may also apply to the association of verbal and visuospatial information involved in bootstrapping. Crucially, the effect appears to utilize *pre-existing* associations between verbal and spatial information. Darling, Allen, Havelka, Campbell, and Rattray (2012; see also Darling, Parker, Goodall, Havelka, & Allen, 2014) compared verbal recall using typical keypad and single location displays, with two new conditions that preserved the basic keypad layout but randomized digit locations within these arrays (thus removing the long-term component). While the advantage for recall using typical keypad arrays was replicated, randomized arrays showed no benefit relative to the single location condition. The bootstrapping effect therefore appears to draw on stored keypad knowledge in order to benefit from verbal-spatial associations, thus providing a useful method to explore interaction and binding between multiple domains of processing and LTM. This requirement for the presence of long-term representations in order for participants to derive a visuospatial bootstrapping advantage means that this effect may be characterized as a form of ‘expert’ memory (e.g. Chase & Simon, 1973; Ericsson & Kintsch, 1995) that is reliably observed across young adult participants, and furthermore that it can be differentiated from previous observations of simple dual coding benefits in memory (Brooks, 1967; Paivio, 1971, 1991). It is not the basic visuospatial information that facilitates recall, but, crucially, the familiar and meaningful association between visuospatial and verbal material.

The current study utilized visuospatial bootstrapping to examine how potential subcomponents of working memory may contribute to the online combination of verbal and spatial information in the environment, based on stored long-term knowledge. According to Baddeley et al. (2011), information from different modalities (e.g. verbal and visuospatial) is

initially processed within modality-specific storage capacities before being integrated within the episodic buffer. Thus, support may be required from verbal and spatial subcomponents in order to provide the ‘raw materials’ for binding between these domains. In line with this, Ericsson and Kintsch (1995) suggested that higher-level processing requires lower level outputs to be initially retained in specialized memory buffers, before being integrated. Some initial support does exist to support these claims; intentional verbal-spatial binding appears to be negatively impacted by concurrent articulatory suppression (Morey, 2009) and phonological similarity (Guerard, Tremblay, & Saint-Aubin, 2009), thus indicating the contribution of phonological WM to the temporary binding of verbal and spatial information. Once bound, however, it may be that modality-specific processes become less important; Langerock et al. (2014) have recently found that verbal and spatial loads applied during retention have equivalent effects on memory for single features and verbal-spatial conjunctions. Exploring these issues in the context of visuospatial bootstrapping provides novel insights concerning how possible episodic buffer functioning might be reliant on or separable from different WM subcomponents, and how multimodal binding with support from LTM might protect and facilitate memory performance relative to single modality processing.

Based on dual-task logic, any task that involves verbal or spatial processing should be particularly disrupted by the concurrent performance of additional activities that load on these WM components. This basic approach was applied in three experiments, in which digit sequences were visually presented (either in single locations or within familiar ‘keypad’ arrays) under conditions of verbal (Experiment 1) or spatial (Experiment 2) working memory load. The final experiment (Experiment 3) shifted the spatial load to the recall phase of the primary task. We expected to firstly replicate previous observations of a visuospatial bootstrapping advantage under no load conditions (e.g. Darling et al., 2012). We also

anticipated negative effects of articulatory suppression and spatial tapping on performance in each of the display conditions. Furthermore, if verbal and spatial WM resources make differential contributions to performance in the different display conditions, this should be reflected in the relative magnitude of effects. Specifically, we anticipated that verbal WM would be relatively more important for recall in the single digit condition and thus that there would be greater impact of concurrent articulatory suppression on single digit presentations in Experiment 1, while spatial WM would contribute more to recall when digits are presented within familiar keypad arrays, predicting larger disruption by concurrent spatial tapping in the keypad condition in Experiment 2. Comparison of effects when spatial load is shifted from encoding to recall (Experiment 3) would indicate whether this is important throughout all stages of the task, or whether spatial processing is only important during initial binding of verbal and spatial information; the latter outcome would indicate the creation of modality-general representations within the episodic buffer.

Experiment 1

This first study examined the impact of concurrent articulatory suppression (AS) on digit recall performance following visual presentation either using single locations or standard keypad arrays. AS is a standard methodological tool that involves participants repeatedly articulating a simple word or phrase. It is commonly used to disrupt verbal recoding of visually presented stimuli and prevent articulatory rehearsal strategies that might otherwise keep verbal representations active over time (e.g. Baddeley, Thomson, & Buchanan, 1975; Baddeley, Lewis, & Vallar, 1984; Murray, 1968), while minimally impacting on central executive control resources (e.g. Morey & Cowan, 2004). In particular, for the highly familiar numerical stimuli used in the current study, it is likely that suppression particularly impacts on ongoing phonological maintenance and rehearsal, while still allowing initial derivation of a phonological code from written material (Besner, 1987). We therefore implemented it in the

present study to examine how memory for digits presented within a meaningful spatial configuration or in a single location might draw on verbal storage and rehearsal.

Given that both conditions involve visual presentation of to-be-recalled verbal information, we expected to find a substantial general effect of AS on performance, through the requirement to verbally maintain digit sequences. If the bootstrapping effect generally relies on WM in a modality-independent manner, it should be selectively impaired by any concurrent task, meaning that we would expect to find relatively larger impacts of AS on the keypad condition. However, Morey (2009) observed that visually presented letter discrimination during concurrent AS was superior when maintenance of letters within spatial locations (i.e. as part of cross-domain binding) was encouraged, relative to when letter location was irrelevant. Thus, an alternative possibility is that dependence on verbal coding is reduced, as implicit binding of verbal information with a familiar spatial configuration in the keypad condition might protect against AS interference through the provision of representational formats that are independent of the phonological loop. In contrast, for the single location condition, the lack of meaningful variation in spatial information would leave performance more dependent on transient visual representations of the presented digits and associated verbal code maintained through rehearsal by the participant. Recall in this case should therefore be relatively more vulnerable to interference from a concurrent verbal task that particularly disrupts the rehearsal process.

Method

Participants

Thirty-two participants (8 males, 24 females; mean age 22.1, range 18-47, $SD = 5.67$) took part in this experiment. All were students or staff members at the University of Leeds.

Design

A 2x2 repeated measures design was implemented, manipulating display type (single vs. keypad) and concurrent task (no task vs. articulatory suppression). All participants took part in all conditions within a single session, in a fully counterbalanced order. The dependent variable was the mean proportion of digits correctly recalled in each condition.

Materials and Procedure

Testing was controlled on a 13" Macbook, using a programme written in SuperCard 4.7. Each trial was initiated by participants pressing a space bar, and began with a fixation cross presented centrally for 500ms followed by a 250ms blank screen delay, before the sequence started. Digits were presented in Arial font (black, size 36) within black square outlines 60x60px in size (see Figure 1). Each display was presented for 500ms, with the target digit indicated by highlighting the background in green, with displays separated by 500ms blank screen inter-stimulus intervals. For the single digit display, each item was presented in isolation at screen centre. For the typical keypad display, all 10 digits (0-9) were presented in a familiar keypad layout, with 12px separating each square. Participants attempted to verbally recall the entire digit sequence in its original order immediately upon offset of the final item.

<Figure 1>

Each session started with a span test (using the single digit display condition) in order to ascertain sequence length to use for each participant. Following one practice trial containing a two-digit sequence, a standard span procedure was implemented with length progressively increased from 2-10 digits, with two sequences at each length. Testing continued until participants failed to correctly recall in order either of the sequences at a given length, with span classed as the maximum length at which at least one sequence was accurately recalled. The four experimental conditions then followed, with each containing 1 practice trial and 20 test trials performed at the same predetermined sequence span length.

Articulatory suppression was performed from the point of fixation through to the end of the sequence presentation (and the start of the recall phase). For this task, participants were required to repeatedly vocalize the phrase *coca-cola* at a rate of approximately one per second.

Results

Participants achieved a mean span score of 6.84 (SE = .17) in the pretest, with this being the mean sequence length implemented in the subsequent experimental conditions. Strict serial position scoring criteria were applied to the latter data, to yield a measure of mean proportion of digits correctly recalled per sequence¹. This is displayed in Figure 2, for each display type and concurrent task condition. A 2x2 repeated measures ANOVA revealed significant effects of display type, $F(1,31) = 66.59$, $\eta p^2 = .68$, $p < .001$, and articulatory suppression, $F(1,31) = 397.11$, $\eta p^2 = .93$, $p < .001$, indicating superior recall for digits in the keypad condition relative to single digit displays, and a substantial negative effect of suppression. In addition, there was a significant interaction between display type and concurrent task, $F(1,31) = 5.51$, $\eta p^2 = .15$, $p < .05$. Further analyses revealed that articulatory suppression had significant effects on both single digit, $t(31) = 15.32$, $p < .001$, and keypad conditions, $t(31) = 11.53$, $p < .001$, though effect size was considerably larger for the single digit condition ($d = 1.96$) than for keypad recall ($d = 1.19$).

Discussion

This experiment replicated the basic advantage in digit recall for the typical keypad displays over the single location condition, indicating the visuospatial bootstrapping effect (Darling & Havelka, 2010; Darling et al., 2012, 2014) to be a robust and reliable phenomenon.

Articulatory suppression had a substantial deleterious effect on digit recall performance in both conditions, revealing an expected role for the phonological loop (Baddeley & Hitch,

1974) in this task. Importantly, the negative effect of this concurrent activity was significantly larger for recall of digits from the single location condition, relative to the keypad display condition. It appears that the availability of meaningful spatial information not only facilitates verbal recall performance in general, but also reduces the relative reliance on phonological WM and resulting susceptibility to disruption by concurrent verbal suppression.

Experiment 2

We would argue that the larger effects of AS on single location recall relative to keypad recall in Experiment 1 reflects a stronger relative reliance on modality-specific processing; specifically, the set up and maintenance (through rehearsal) of phonological representations. An alternative possibility, however, is that the availability of stored configural knowledge to support digit recall may protect performance against any form of working memory load, regardless of modality. Experiment 2 replaced articulatory suppression with a simple spatial analogue (spatial tapping) to examine whether differential patterns of concurrent task effects are general or modality-specific in nature. Spatial tapping typically involves participants repeatedly tapping out a simple sequence at a steady pace on a spatial array. It can be dissociated from impacts of AS and provides a straightforward and reliable method of examining the involvement of visuospatial working memory in various cognitive tasks (e.g. Barton, Mathews, Farmer, & Belyavin, 1995; Brown & Wesley, 2013; Darling, Della Sala, & Logie, 2009; Farmer, Berman, & Fletcher, 1986; Larsen & Baddeley, 2003; Pearson, Logie, & Gilhooly, 1999) while placing relatively minimal load on phonological processing or central executive control (e.g. Barton et al., 1995; Chincotta, Underwood, Abd Ghani, Papadopoulou, & Wresinski, 1999; Smyth & Pelky, 1992). The effects of spatial tapping may be even more specific, with studies (e.g. Darling et al., 2009; Della Sala, Gray, Baddeley, Allemano, & Wilson, 1999) suggesting that this task particularly loads on a spatial WM

component, termed the ‘inner scribe’ by Logie (1995, 2003), that may be separable from visual storage (termed the ‘visual cache’).

While the use of visuospatial information in the primary task appears to require the availability of stored configural knowledge in LTM (Darling et al., 2012, 2014), its initial utilization is nevertheless assumed to be visuospatial in nature, and thus rely on these subcomponents of WM. In support of this, Tanaka et al. (2002) used fMRI to examine the superior digit recall performance of expert mental abacus users, and found that they showed activation in bilateral fronto-parietal areas involved in visuospatial processing, while non-experts showed activation in areas responsible for verbal WM, including Broca’s area. The visuospatial bootstrapping paradigm may provide a more widely accessible method of examining similar processes of interaction between verbal and spatial information using long-term knowledge. We therefore predicted that spatial tapping performed concurrently during presentation of the digit sequences would have a significantly more disruptive impact on performance when digits were presented within a typical keypad configuration, relative to a single digit location condition.

Method

Participants

Thirty-two participants (5 males, 27 females; mean age 19.4, range 18-23, $SD = 1.04$) took part in this experiment. All were students at the University of Leeds.

Design

A 2x2 repeated measures design was implemented, manipulating display type (single vs. keypad) and concurrent task (no task vs. spatial tapping). All participants took part in all

conditions within a single session, in a fully counterbalanced order. The dependent variable was the mean proportion of digits correctly recalled in each condition.

Materials and Procedure

Materials and testing procedure were closely based on Experiment 1. The main difference in this experiment was that spatial tapping was implemented in the concurrent task condition. For this task, participants were required to concurrently perform a spatial tapping task throughout the encoding phase, from fixation cross to final item offset. This was performed on a set of 4 black felt pads (each sized 2.8cm²) attached to a secure base and arranged in a cross formation (see Figure 1 inset), with a regular *up-down-left-right* movement required at approximately two taps per second. Participants were permitted to familiarize themselves with the configuration and pattern of motion before starting the first of the tapping conditions. The spatial array was then placed out of view behind a screen (though still in easy reach of the participant) during task performance, in order to minimize visual disruption and emphasize the spatial nature of the task. In the no tapping condition, participants were not required to concurrently perform any action during encoding.

Results

Participants achieved a mean span score of 6.97 (SE = .14) in the pretest, with this being the mean sequence length implemented in the subsequent experimental conditions. Strict serial position scoring criteria were applied to the latter data, to yield a measure of mean proportion of digits correctly recalled per sequence². This is displayed in Figure 3, for each display type and concurrent task condition. A 2x2 repeated measures ANOVA revealed significant effects of display type, $F(1,31) = 4.55$, $\eta^2 = .13$, $p < .05$, and spatial tapping, $F(1,31) = 115.14$, $\eta^2 = .79$, $p < .001$, indicating superior recall for digits in the keypad condition relative to single digit displays, and a substantial negative effect of spatial tapping. In addition, there was

a significant interaction between display type and concurrent task, $F(1,31) = 4.71$, $\eta p^2 = .13$, $p < .05$. Further analyses revealed that spatial tapping had significant effects on both single digit, $t(31) = 5.91$, $p < .001$, and keypad conditions, $t(31) = 8.38$, $p < .001$, though effect size was considerably larger for keypad recall ($d = 1.56$) than for the single digit condition ($d = 0.92$). In particular, the significant advantage for keypad over single location displays was present in the no load condition, $t(31) = 5.61$, $p < .001$, $d = .89$, but not in the spatial tapping condition, $t(31) = .08$, $p = .94$, $d = .02$.

Discussion

This experiment again successfully replicated the bootstrapping effect (Darling & Havelka, 2010; Darling et al., 2012, 2014); participants do reliably make use of available, meaningful verbal-spatial associations when recalling digit sequences. We also observed a large impact of concurrent spatial tapping on both display conditions. It is likely that the requirement to encode visually presented stimuli loads on visuospatial processing regardless of particular configurations or response formats (e.g. Brown & Wesley, 2013), hence why such effects emerged even in the single location condition. Indeed, Chincotta et al. (1999) observed significant effects of a similar spatial tapping task on digit recall (using single location presentation), and argued for a spatial component in encoding and storing digit numerals.

Most importantly, a significant display by task interaction emerged, with larger disruptive effects of spatial tapping on recall in the keypad condition. In fact, performing the concurrent tapping task during sequence presentation abolished the bootstrapping effect. This experiment provides the first evidence that the bootstrapping advantage emerges through processes taking place during encoding, rather than at storage or later recall. Specifically, it appears that when spatial WM resources are loaded using an additional task during encoding, participants are no longer able to utilize spatial information in the environment to boost

performance. Thus, availability of domain-specific resources does appear to be important in supporting the construction and utilization of cross-domain associations.

The findings of Experiment 2 might reflect importance of spatial processing availability during initial binding of verbal and spatial information, with subsequent retention in a modality-general store such as the episodic buffer (Baddeley, 2000). One alternative possibility, however, is that verbal and spatial information is stored in separate modality-specific streams (Cowan, Saults, & Morey, 2006), with both independently feeding into recall performance. While still reflecting the interaction of different domains in supporting WM performance, this suggestion might explain the different patterns of AS and ST effects without the need to posit an additional general storage capacity such as the episodic buffer. This question was examined in a final experiment, in which spatial load was shifted to the recall phase.

Experiment 3

In this final experiment, participants were free to initially encode the digit sequences without any additional task requirement, but in the interference conditions, began performing spatial tapping at the same time as they commenced verbal recall. If the bootstrapping recall advantage is due to information from different modalities being stored separately and then independently informing recall performance, the pattern of interference effects should be the same when spatial tapping is moved to the recall phase as when it is implemented at encoding. In contrast, if the bootstrapping effect reflects initial binding of verbal and spatial information during encoding within a modality-general component such as the episodic buffer, then the display by tapping interaction will not be observed when tapping is only performed at recall; the bindings will already have been set up, so the keypad condition will no longer be vulnerable to spatially-oriented interference.

Method

Participants

Thirty-two participants (6 males, 26 females; mean age 20.2, range 18-32, $SD = 3.28$) took part in this experiment. All were students at the University of Leeds.

Design, Materials, and Procedure

The experimental design, materials, and procedure were identical to that used in Experiment 2. The exception was that participants performed the spatial tapping task during the recall phase, commencing tapping as soon as digit presentation ended and continuing until they had completed their recall attempt.

Results

Participants achieved a mean span score of 7.09 ($SE = .17$) in the pretest, with this being the mean sequence length implemented in the subsequent experimental conditions. Mean proportion of digits correctly recalled per sequence was again used as the primary DV³. This is displayed in Figure 4, for each display type and concurrent task condition. A 2x2 repeated measures ANOVA revealed significant effects of display type, $F(1,31) = 11.97$, $\eta p^2 = .28$, $p < .01$, and spatial tapping, $F(1,31) = 20.85$, $\eta p^2 = .40$, $p < .001$, indicating superior recall for digits in the keypad condition relative to single digit displays, and a negative effect of spatial tapping. However, the interaction between display type and concurrent task was not significant, $F(1,31) = .01$, $\eta p^2 = .00$, $p = .94$.

Discussion

With spatial tapping shifted to the response phase, this experiment replicated the two main effects that were observed in Experiment 2; digit recall was superior following the keypad presentation (i.e. the bootstrapping effect was again observed), and spatial tapping negatively

impacted on performance. This latter finding would at least partly reflect a dual-response bottleneck (see also Hegarty, Shah, & Miyake, 2000), with participants required to concurrently respond in two different tasks. However, the critical finding in this experiment was that, with tapping performed during recall instead of encoding, the interaction between presentation method and concurrent task was not significant. Therefore, following initial encoding, spatial WM resources were not differentially important for digit recall as a function of how the information was originally presented. These findings will be discussed further in the following section.

General Discussion

Three experiments replicated the visuospatial bootstrapping advantage previously observed by Darling et al. (2012, 2014; Darling & Havelka, 2010); digit recall was reliably superior when digits were presented within a familiar spatial keypad array, relative to presentation in a single location. Given that this effect involves combining information from separable (verbal and spatial) domains, the key question in the current study concerned how processing in these domains may contribute to such cross-domain binding, and the implications this may have for models of working memory. As expected, performance of simple tasks requiring verbal or spatial processing during stimulus presentation negatively impacted on digit recall performance following both display conditions, indicating contributions of these specialized sub-components of working memory regardless of how the information was encountered. However, the relative magnitude of these disruptive effects varied with display configuration when the concurrent tasks were performed at encoding, in line with our a priori predictions; single location recall was relatively more susceptible to disruption from articulatory suppression (Experiment 1), while recall following keypad presentation showed greater disruption by concurrent spatial tapping (Experiment 2), though not when the latter task was shifted to the recall phase (Experiment 3). This novel pattern of findings provides new

insights for models of working memory, and in particular how specialized sub-systems might contribute to the interaction between these systems and stored knowledge in LTM.

As previously suggested (Darling et al., 2012, 2014; Darling & Havelka, 2010), the visuospatial bootstrapping effect reflects binding of verbal and spatial information based on stored configural knowledge. This may be served by a modality-general storage capacity such as the episodic buffer within the multicomponent model of working memory (Baddeley, 2000). According to (Baddeley et al., 2011), the episodic buffer is directly connected to modality-specific subcomponents responsible for processing visual and spatial information and phonological information respectively, with information from the environment feeding into the episodic buffer via these specialized capacities. This general approach is supported by the present work, with the underlying processing indexed by the bootstrapping effect responding in distinct ways to varying forms of concurrent disruption, suggesting an interactive relationship between cross-domain storage and separable, specialized processing capacities.

Articulatory suppression particularly impacts on the maintenance and rehearsal of familiar visually presented verbal material (Besner, 1987). Performance in the single digit condition is heavily dependent on verbal maintenance due to the absence of other environmental cues, and therefore particularly suffers when this is prevented. In contrast, the availability of a familiar spatial configuration in which to embed to-be-remembered digit sequences reduces the reliance on verbal working memory, and with it the impact of AS. These findings from Experiment 1 fit with Morey's (2009) observation of superior letter recognition memory under suppression when participants were encouraged to bind letters to their spatial locations. Morey suggested that verbal-spatial associations are retained within the episodic buffer (Baddeley, 2000) or Cowan's (2004) focus of attention, and are hence

somewhat preserved from domain-specific interference. The present findings extend this to the use of familiar verbal-spatial associations in a digit recall task.

In contrast to the reduced impact of AS, however, the relatively larger impact of spatial tapping on keypad recall observed in Experiment 2 (and the resulting abolition of the bootstrapping advantage) would nevertheless suggest that domain-specific processes are critical for the activation and utilization of familiar verbal-spatial associations in order to facilitate recall. It appears that sufficient visuospatial resources should be available in order for verbal recall to benefit from the familiar keypad configuration; when these are loaded by concurrent spatial tapping, participants can no longer draw on this spatial information, and may instead rely on verbal working memory. Thus, in addition to storage in the episodic buffer, modality-specific storage also remains available should cross-domain binding be de-emphasized or prevented, as in the case of spatial tapping. This reflects the flexible nature of working memory, with different strategies and processes potentially employed to suit different situations (Logie, 2011; Morey, 2009). We would suggest that, in the case of visuospatial bootstrapping, availability of spatial resources is important for the development of verbal-spatial binding in the episodic buffer. It remains to be seen whether these resources are required for coding directly into the buffer itself, or for creation of visuospatial representations which are then drawn into this modality-general store.

One alternative explanation for the findings from Experiments 1 and 2 might be that, rather than requiring cross-domain storage from the point of encoding, verbal and visuospatial information is held in parallel within modality-specific stores, with each used at retrieval to inform recall performance. Cowan et al. (2006) noted such a possibility in a task requiring memory for sequences of arbitrary pairings of names and locations. In this way, the process of cross-modal integration might occur during retrieval rather than encoding. However, this class of suggestion is undermined by the complete absence of any interaction between display type

and spatial tapping in Experiment 3, when tapping was performed during recall instead of encoding. If the bootstrapping advantage was solely the result of participants being able to draw on modality-specific spatial representations at recall, spatial tapping at this phase should have also reduced or abolished the advantage. Instead, Experiments 2 and 3 combined indicate that spatial processing is key to initial formation of domain-general representations within the episodic buffer, but not their subsequent use at recall.

This conclusion is supported by recent observations from Langerock et al. (2014) in their study of memory for visually presented verbal information (letters), spatial locations, or verbal-spatial binding. Tasks loading on verbal or spatial processing were added during short retention intervals separating presentation of each target item; these disrupted performance in the primary memory task to the same extent across feature and binding conditions. Langerock et al. interpreted this to indicate a separation between domain-specific sub-systems and the episodic buffer, with cross-domain associations maintained within the latter limited capacity store. While Experiment 3 in the present study was focused on retrieval rather than retention, the findings nevertheless provide convergent support for the claims of Langerock et al. regarding modality-general storage, but also go further in demonstrating that domain-specific processes do make separable contributions during initial encoding (Experiments 1 and 2). Following on from the work of Langerock et al., it would be of value for future research to examine how visuospatial bootstrapping effects may vary across retention intervals. While this question is outside the scope of the present study (which was focused on immediate recall), it would be useful to establish whether the bootstrapping advantage survives or even increases over time, and what cognitive processes may be involved during these extended maintenance periods.

Domain-general retention of verbal-spatial associations that is connected to but separable from domain-specific processing would fit with our recent developmental

exploration of bootstrapping effects (Darling et al., 2014). In that study, we observed a bootstrapping advantage of equivalent magnitude in 9-year old children and young adults, while a group of 6-year old children did not show this effect. This abrupt emergence of the bootstrapping advantage can be distinguished from the more gradual development of verbal and visuospatial processing through childhood and into adolescence (e.g. Gathercole, 1999). The present dual-task study builds on this distinction; these modality-specific components are clearly involved in the present digit recall tasks, and visuospatial processing appears to be important during initial encoding of familiar verbal-spatial associations, but these are not the only underlying factors driving the effect; cross-domain binding and the application of stored long-term knowledge to working memory are also important.

Previous observations of visuospatial bootstrapping effects only occurred with meaningful configurations (Darling et al., 2012, 2014). This bears comparison with research showing increased expert memory for representative stimuli, and not randomly rearranged versions, in fields such as chess (Chase & Simon, 1973) and music (Sloboda, 1976). Similarly, individuals who (through extensive practice) are highly skilled at using a ‘mental abacus’ strategy to carry out calculations can show superior digit span performance alongside normal span for other materials (e.g. letters), indicating the use of established visuospatial expertise drawn from LTM to supplement digit memory (Hatano & Osawa, 1983). In line with the current findings, an fMRI study of digit recall performance by Tanaka et al. (2002) found that abacus experts showed activation in bilateral fronto-parietal areas linked to visuospatial processing, while for non-experts activity was predominantly in the left hemisphere in regions responsible for verbal WM. In contrast to such expert memory studies, however, knowledge of the keypad configuration as utilized in the present study reliably influences memory in typical groups of older children and young adults, indicating that it can

be generalized beyond a minority of expert users and cognitive skills that require years of specialized practice.

Examining dual-task effects

The application of dual-task logic to working memory has previously been widely and successfully used in driving theoretical developments (see Baddeley, 2007). It is important however to consider the extent to which component tasks are relatively process-pure and load primarily on intended cognitive components. Both articulatory suppression (e.g. Baddeley et al., 1975, 1984; Barton et al., 1995; Farmer et al., 1986; Larsen & Baddeley, 2003; Morey & Cowan, 2004, Morey, 2009) and spatial tapping (e.g. Barton et al., 1995; Brown & Wesley, 2013; Darling et al., 2009; Della Sala et al., 1999; Farmer et al., 1986; Larsen & Baddeley, 2003; Pearson et al., 1999; Smyth & Pelky, 1992) have been frequently utilized for the purposes set out in the current study and their use in this context is non-contentious. Nevertheless, these tasks may also load on additional capacities, as well as modality-specific processing, and these should be considered in light of the present outcomes.

One possibility is that the selective disruption effects observed in Experiments 1 and 2 may reflect input interference, with articulatory suppression and spatial tapping generating general attentional distraction that conflicts with the encoding of phonological or spatial information in the different experiments. However it does not follow that loading on the same general attentional resource by two concurrent tasks would then have directly contrasting effects on encoding of two different forms of information (single and keypad display); if both AS and ST simply load on the same general resource, this logically should impinge in the same way on primary task performance. Though it may be possible to argue that these findings reflect modality specificity of initial attentional resources rather than storage per se, this would still support our interpretation of modality-specific initial processing that varies

between keypad and single conditions. It should be noted that, while we consider how a multimodal account of working memory offers the most compelling and parsimonious account for our data, we do not explicitly reject other theoretical approaches. Nevertheless, the findings suggest that models that de-emphasize a modular approach in favour of a strongly unitary view (e.g. Cowan, 1995, 2005; Oberauer, 2002; Unsworth & Engle, 2007) might at least require some adjustment.

While the contrasting effects of AS and ST are therefore unlikely to simply reflect common impacts of a general attentional load, an alternative view of the spatial tapping task alone might be that it has a substantial executive component in addition to its modality specific effects. For example, processing within the episodic buffer might particularly draw on the central executive at encoding only (and not retrieval), with the executive load placed by spatial tapping disrupting this encoding-based binding process. While we would not presently wish to completely reject the suggestion that spatial tapping does require some level of general attentional control, previous research has suggested that this is relatively minimal and that the disruptive impact of spatial tapping can be dissociated from those produced by executive load tasks (e.g. Allen et al., 2009; Chincotta et al., 1999; Eysenck, Payne, & Derakshan, 2005; Kemps, Szmalec, Vandierendonck, & Crevits, 2005; Smyth & Pelky, 1992). In addition, while the original conception of the episodic buffer identified it as being critically reliant on executive control (Baddeley, 2000), more recent studies have demonstrated that it may operate in a relatively automatic manner, independently of attentional load (see Baddeley et al., 2011). It is therefore unlikely that the abolition of the bootstrapping advantage by spatial tapping observed in Experiment 2 solely reflects an executive load.

It is also worth noting that spatial tapping was observed to disrupt single-location recall in Experiment 2. If this task was entirely pure in its impacts on spatial WM, this type of

pattern might not be expected to occur. Tapping disruption was lower than in the keypad condition of the same experiment, meaning that this pattern does not markedly affect interpretation of the key finding of this study (that tapping abolishes any evidence of a bootstrapping advantage for keypad displays), but it nevertheless merits some attention. Spatial tapping has previously been shown to impact on verbal task performance (e.g. Jones et al., 1995), though it is not always consistently observed (Guerard & Tremblay, 2008; Meiser & Klauer, 1999). Moreover some imprecision in selective interference might be understandable. In the visuospatial bootstrapping paradigm, presentation is visual in all conditions, and thus even the single location condition has a visual component. While visual and spatial components of working memory have been argued to be separable (Darling et al., 2009; Della Sala et al., 1999; Logie, 1995), tapping tasks can impair memory for dynamic visually presented items (Pickering, Gathercole, Hall & Lloyd, 2001). Hence a concurrent tapping task loading on operations associated with the visuospatial sketchpad (under the Baddeley framework) might disrupt *any* visually presented primary task to at least some extent. This may at least partly account for why some spatial tapping effects emerged in the single location condition in Experiment 2. As indicated by the name of the phenomenon, we do not wish to argue that visuospatial bootstrapping is critically reliant only on spatial processing, but rather that it draws on specialized visuospatial capacities in boosting verbal working memory performance.

To conclude this section, very few tasks are entirely process-pure, and thus it is likely that both articulatory suppression and spatial tapping involve elements additional to disruption of verbal rehearsal and spatial processing. However, spatial tapping clearly does have a strong spatial component, and the findings observed in Experiments 2 and 3 are in line with our a priori predictions regarding how spatial processing might contribute to visuospatial bootstrapping during encoding and retrieval. As such our interpretation provides a clearly

motivated and parsimonious account of the pattern of effects observed. While the present study was focused on verbal and spatial modality-specific processing, it will be fruitful for further research to examine whether other processes (for example, executive attention or motoric processing) are also critical to visuospatial bootstrapping.

Conclusions

Overall, the present study demonstrates across three experiments that the visuospatial bootstrapping advantage is not only highly reliable, but responds in contrasting yet logical ways to dual task manipulations. The availability of familiar verbal-spatial associations facilitates digit recall and reduces reliance on maintenance in verbal working memory. This effect initially emerges at encoding and requires spatial processing resources to support the activation of verbal-spatial associations. Once these are set up within a domain-general storage capacity such as the episodic buffer, spatial processing is then no longer critical.

References

- Allen, R.J., Baddeley, A.D., & Hitch, G.J. (2006). Is the binding of visual features in working memory resource-demanding? *Journal of Experimental Psychology: General*, *135*, 298-313.
- Allen, R.J., Baddeley, A.D., & Hitch, G.J. (2014). Evidence for two attentional components in visual working memory. *Journal of Experimental Psychology: Learning, Memory, & Cognition*.
- Allen, R.J., & Hitch, G.J., & Baddeley, A.D. (2009). Cross-modal binding and working memory. *Visual Cognition*, *17* (1/2), 83-102.

- Allen, R.J., Hitch, G.J., Mate, J., & Baddeley, A.D. (2012). Feature binding and attention in working memory: A resolution of previous contradictory findings. *The Quarterly Journal of Experimental Psychology*, 65 (12), 2369-2383.
- Baddeley, A. (2000). The episodic buffer: A new component of working memory? *Trends in Cognitive Sciences*, 4(11), 417-423.
- Baddeley, A. (2007). *Working memory, thought, and action*. Oxford University Press.
- Baddeley, A.D. (2012). Working memory: Theories, models, and controversies. *Annual Review of Psychology*, 63, 1-29.
- Baddeley, A.D., Allen, R.J., & Hitch, G.J. (2011). Binding in visual working memory: The role of the episodic buffer. *Neuropsychologia*, 49(6), 1393-1400.
- Baddeley, A.D., & Hitch, G. J. (1974). Working memory. *The Psychology of Learning and Motivation*, 8, 47-89.
- Baddeley, A. D., Hitch, G. J., & Allen, R. J. (2009). Working memory and binding in sentence recall. *Journal of Memory and Language*, 61(3), 438-456.
- Baddeley, A.D., Lewis, V., & Vallar, G. (1984). Exploring the articulatory loop. *The Quarterly Journal of Experimental Psychology*, 36 (2), 233-252.
- Baddeley, A.D., Thomson, N., & Buchanan, M. (1975). Word length and the structure of short-term memory. *Journal of Verbal Learning and Verbal Behavior*, 14 (6), 575-589.
- Barrouillet, P., Bernardin, S., Portrat, S., Vergauwe, E., & Camos, V. (2007). Time and cognitive load in working memory. *Journal of Experimental Psychology: Learning, Memory, and Cognition*, 33(3), 570.

- Barton, A., Mathews, B., Farmer, E., & Belyavin, A. (1995). Revealing the basic properties of the visuospatial sketchpad: The use of complete spatial arrays. *Acta Psychologica*, *89*, 197-216.
- Besner, D. (1987). Phonology, lexical access in reading, and articulatory suppression: A critical review. *Quarterly Journal of Experimental Psychology A: Human Experimental Psychology*, *39* (3), 467-478.
- Brooks, L. R. (1967). The suppression of visualization by reading. *Quarterly Journal of Experimental Psychology*, *19*(4), 289-299.
- Brown, L. A., Forbes, D., & McConnell, J. (2006). Limiting the use of verbal coding in the Visual Patterns Test. *Quarterly Journal of Experimental Psychology*, *59*, 1169-1176.
- Brown, L. A., & Wesley, R.W. (2013). Visual working memory is enhanced by mixed strategy use and semantic coding. *Journal of Cognitive Psychology*, *25* (3), 328-338.
- Chase, W. G., & Simon, H. A. (1973). Perception in chess. *Cognitive psychology*, *4*(1), 55-81.
- Chincotta, D., Underwood, G., Abd Ghani, K., Papadopoulou, E., & Wresinski, M. (1999). Memory span for Arabic numerals and digit words: Evidence for a limited-capacity, visuospatial storage system. *The Quarterly Journal of Experimental Psychology*, *52A*, 325-351.
- Cowan, N. (1995). *Attention and memory: An integrated framework*. Oxford Psychology Series, New York.
- Cowan, N. (2004). *Working memory capacity*. Psychology Press.
- Cowan, N., & Morey, C.C. (2007). How can dual-task working memory retention limits be investigated? *Psychological Science*, *18*(8), 686-688.

- Cowan, N., Saults, J. S., & Morey, C. C. (2006). Development of working memory for verbal–spatial associations. *Journal of Memory and Language*, 55(2), 274-289.
- Darling, S., Allen, R.J., Havelka, J., Campbell, A., & Rattray, E. (2012). Visuospatial bootstrapping: Long-term memory representations are necessary for implicit binding of verbal and visuospatial working memory. *Psychonomic Bulletin & Review*, 19 (2) , 258-263.
- Darling, S., Della Sala, S., & Logie, R.H. (2009). Dissociation between appearance and location within visuo-spatial working memory. *The Quarterly Journal of Experimental Psychology*, 62 (3), 417-425.
- Darling, S., & Havelka, J. (2010). Visuospatial bootstrapping: Evidence for binding of verbal and spatial information in working memory. *The Quarterly Journal of Experimental Psychology*, 63(2), 239-245.
- Darling, S., Parker, M.J., Goodall, K.E., Havelka, J., & Allen, R.J. (2014). Visuospatial bootstrapping: Implicit binding of verbal working memory to visuospatial representations in children and adults. *Journal of Experimental Child Psychology*, 119, 112-119.
- Davis, L.C., Rane, S., & Hiscock, M. (2013). Serial recall of visuospatial and verbal information with and without material-specific interference: Implications for contemporary models of working memory. *Memory*, 21 (7), 778-797.
- Della Sala, S., Gray, C., Baddeley, A., Allamano, N., & Wilson, L. (1999). Pattern span: A tool for unwelding visuo-spatial memory. *Neuropsychologia*, 37, 1189-1199.

- Engle, R. W. (2010). Role of working-memory capacity in cognitive control. *Current Anthropology*, 51(S1), S17-S26.
- Engle, R. W., Tuholski, S. W., Laughlin, J. E., & Conway, A. R. (1999). Working memory, short-term memory, and general fluid intelligence: a latent-variable approach. *Journal of Experimental Psychology: General*, 128(3), 309-331.
- Ericsson, K. A., & Kintsch, W. (1995). Long-term working memory. *Psychological Review*, 102 (2), 211.
- Eysenck, M.W., Payne, S., & Derakshan, N. (2005). Trait anxiety, visuospatial processing, and working memory. *Cognition and Emotion*, 19 (8), 1214-1228.
- Farmer, E.W., Berman, J.V.F., & Fletcher, Y.L. (1986). Evidence for a visuo-spatial scratch-pad in working memory. *The Quarterly Journal of Experimental Psychology*, 38A, 675-688.
- Gathercole, S. (1999). Cognitive approaches to the development of short-term memory. *Trends in Cognitive Sciences*, 3, 410-419.
- Guérard, K., & Tremblay, S. (2008). Revisiting evidence for modularity and functional equivalence across verbal and spatial domains in memory. *Journal of Experimental Psychology: Learning, Memory, and Cognition*, 34(3), 556.
- Guérard, K., Tremblay, S., & Saint-Aubin, J. (2009). Similarity and binding in memory: Bound to be detrimental. *The Quarterly Journal of Experimental Psychology*, 62(1), 26-32.

- Hatano, G., & Osawa, K. (1983). Digit memory of grand experts in abacus-derived mental calculation. *Cognition*, *15*(1), 95-110.
- Hegarty, M., Shah, P., & Miyake, A. (2000). Constraints on using the dual-task methodology to specify the degree of central executive involvement in cognitive tasks. *Memory & Cognition*, *28* (3), 376-385.
- Jarrold, C., Tam, H., Baddeley, A.D., & Harvey, C.E. (2011). How does processing affect storage in working memory tasks? Evidence for both domain-general and domain-specific effects. *Journal of Experimental Psychology: Learning, Memory, and Cognition*, *37*(3), 688.
- Jones, D., Farrand, P., Stuart, G., & Morris, N. (1995). Functional equivalence of verbal and spatial information in serial short-term memory. *Journal of Experimental Psychology: Learning, Memory, and Cognition*, *21*(4), 1008.
- Kemps, E., Szmalec, A., Vandierendonck, A., & Crevits, L. (2005). Visuo-spatial processing in Parkinson's disease: evidence for diminished visuo-spatial sketch pad and central executive resources. *Parkinsonism and Related Disorders*, *11*, 181-186.
- Langerock, N., Vergauwe, E., & Barrouillet, P. (2014). The maintenance of cross-domain associations in the episodic buffer. *Journal of Experimental Psychology: Learning, Memory, & Cognition*.
- Larsen, J.D., & Baddeley, A.D. (2003). Disruption of verbal STM by irrelevant speech, articulatory suppression, and manual tapping: Do they have a common source? *Quarterly Journal of Experimental Psychology A: Human Experimental Psychology*, *56* (8), 1249-1268.
- Logie, R. H. (1995). *Visuo-spatial working memory*. Psychology Press.

- Logie, R. H. (2003). Spatial and visual working memory: A mental workspace. *Psychology of learning and motivation, 42*, 37-78.
- Logie, R. H. (2011). The functional organization and capacity limits of working memory. *Current Directions in Psychological Science, 20*(4), 240-245.
- Mate, J., Allen, R. J., & Baqués, J. (2012). What you say matters: Exploring visual–verbal interactions in visual working memory. *The Quarterly Journal of Experimental Psychology, 65*(3), 395-400.
- Meiser, T., & Klauer, K. C. (1999). Working memory and changing-state hypothesis. *Journal of Experimental Psychology: Learning, Memory, and Cognition, 25*(5), 1272.
- Morey, C. C. (2009). Integrated cross-domain object storage in working memory: Evidence from a verbal–spatial memory task. *The Quarterly Journal of Experimental Psychology, 62*(11), 2235-2251.
- Morey, C.C. (2011). Maintaining binding in working memory: Comparing the effects of intentional and incidental affordances. *Consciousness and Cognition, 20*, 920-927.
- Morey, C. C., & Cowan, N. (2004). When visual and verbal memories compete: Evidence of cross-domain limits in working memory. *Psychonomic Bulletin & Review, 11*(2), 296-301.
- Morey, C. C., & Cowan, N. (2005). When do visual and verbal memories conflict? The importance of working-memory load and retrieval. *Journal of Experimental Psychology: Learning, Memory, and Cognition, 31*(4), 703.

- Morey, C. C., & Mall, J. T. (2012). Cross-domain interference costs during concurrent verbal and spatial serial memory tasks are asymmetric. *The Quarterly Journal of Experimental Psychology*, 65(9), 1777-1797.
- Murray, D. J. (1968). Articulation and acoustic confusability in short-term memory. *Journal of Experimental Psychology*, 78(4p1), 679.
- Oberauer, K. (2002). Access to information in working memory: Exploring the focus of attention. *Journal of Experimental Psychology: Learning, Memory, and Cognition*, 28(3), 411-421.
- Paivio, A. (1971). *Imagery and Verbal Processes*. Holt, Rinehart, and Winston, New York (Reprinted 1979, Erlbaum, Hillsdale, New Jersey)
- Paivio, A. (1991). Dual coding theory: Retrospect and current status. *Canadian Journal of Psychology*, 45(3), 255-287.
- Pickering, S.J., Gathercole, S.E., Hall, M. & Lloyd, S.A. (2001). Development of memory for pattern and path: Further evidence for the fractionation of visuo-spatial memory. *The Quarterly Journal of Experimental Psychology*, 54A(2), 397-420.
- Pearson, D.G., Logie, R.H., & Gilhooly, K.J. (1999). Verbal representations and spatial manipulation during mental synthesis. *European Journal of Cognitive Psychology*, 11(3), 295-314.
- Sloboda, J. A. (1976). Visual perception of musical notation: Registering pitch symbols in memory. *The Quarterly Journal of Experimental Psychology*, 28(1), 1-16.

- Smyth, M.M., & Pelky, P.L. (1992). Short-term retention of spatial information. *British Journal of Psychology*, 83(3), 359-374.
- St Clair-Thompson, H.L., & Allen, R.J. (2013). Are forward and backward recall the same? A dual-task study of digit recall. *Memory & Cognition*, 1-14.
- Tanaka, S., Michimata, C., Kaminaga, T., Honda, M., & Sadato, N. (2002). Superior digit memory of abacus experts: an event-related functional MRI study. *Brain Imaging*, 13 (17), 2187-2191.
- Ueno, T., & Saito, S. (2013). The role of visual representations within working memory for paired-associate and serial order of spoken words. *The Quarterly Journal of Experimental Psychology*, 1-15.
- Unsworth, N., & Engle, R.W. (2007). The nature of individual differences in working memory capacity: active maintenance in primary memory and controlled search from secondary memory. *Psychological review*, 114 (1), 104.

Footnotes

1. Previous work on bootstrapping (Darling & Havelka, 2010; Darling et al., 2012) has used mean proportion of trials on which all items were successfully recalled as the main DV. Mean proportion of fully recalled sequences was not analyzed in this experiment, as a number of participants performed at floor in the articulatory suppression conditions on this measure, failing to correctly recall any full sequence.

2. Analysis of mean proportion of trials on which all items were successfully recalled revealed equivalent patterns of data, with significant effects of display type, $F(1,31) = 6.89$, $\eta p^2 = .18$, $p < .05$, concurrent task, $F(1,31) = 128.43$, $\eta p^2 = .81$, $p < .001$, and the display x task interaction, $F(1,31) = 8.47$, $\eta p^2 = .22$, $p < .01$. Paired samples t-tests showed a significant bootstrapping effect in the no task condition, $t(31) = 4.82$, $p < .001$, $d = .72$, but not with spatial tapping, $t(31) = .01$, $p = .906$, $d = .02$.

3. Analysis of mean proportion of trials on which all items were successfully recalled revealed equivalent patterns of data, with significant effects of display type, $F(1,31) = 22.70$, $\eta p^2 = .42$, $p < .001$, concurrent task, $F(1,31) = 18.13$, $\eta p^2 = .37$, $p < .001$, but no display x task interaction, $F(1,31) = .06$, $\eta p^2 = .00$, $p = .81$.

Author's note

We would like to thank Sadia Aslam, Heather Parr, and Chloe Smith for their assistance with data collection.

Figure captions

Figure 1. Illustration of a) presentation method in each display condition, and b) spatial tapping layout used in Experiments 2 and 3, with arrows indicating direction of tapping sequence

Figure 2. Mean proportion correct per sequence (with standard error) in Experiment 1

Figure 3. Mean proportion correct per sequence (with standard error) in Experiment 2

Figure 4. Mean proportion correct per sequence (with standard error) in Experiment 3

Figure 1

a).

Single location presentation

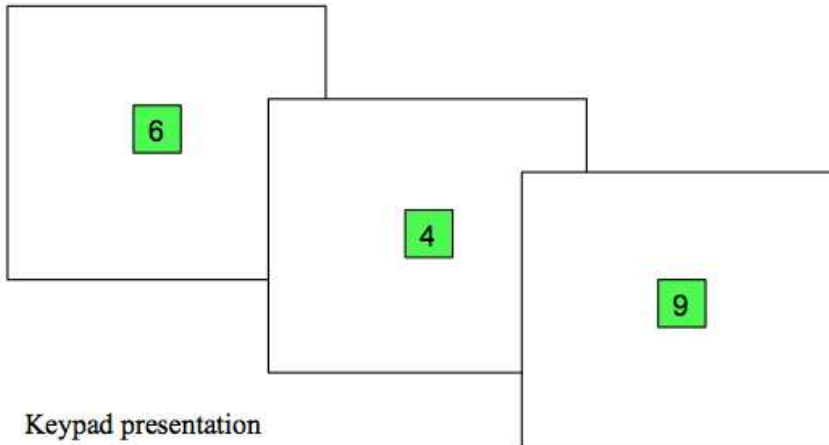

Keypad presentation

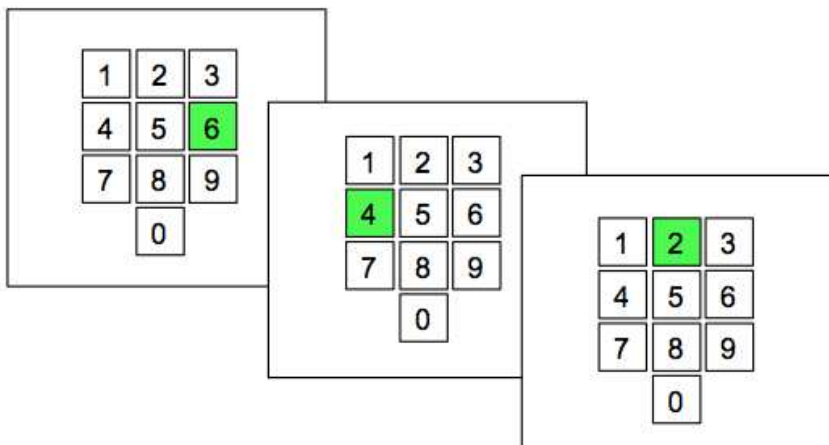

Etc.....Verbal recall

Etc.....Verbal recall

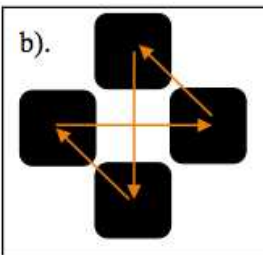

Figure 2

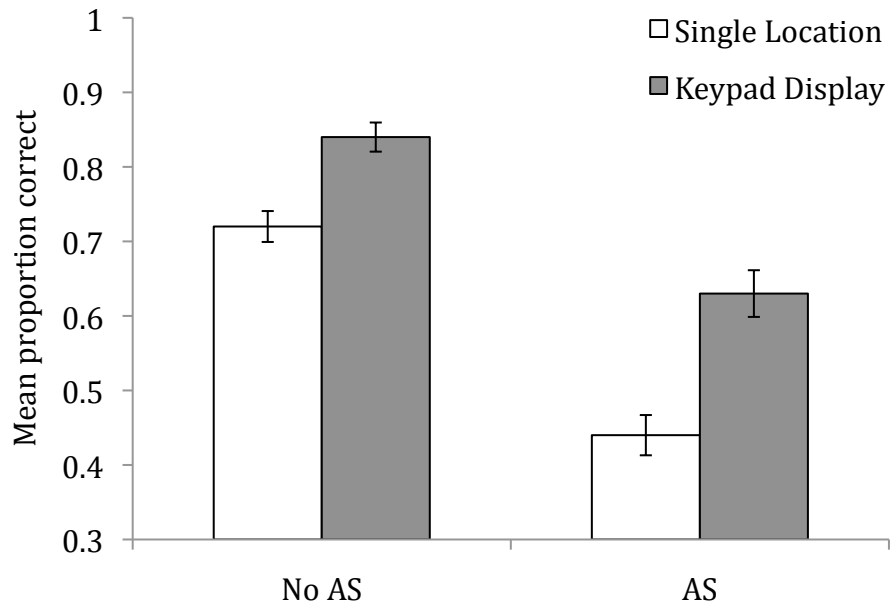

Figure 3

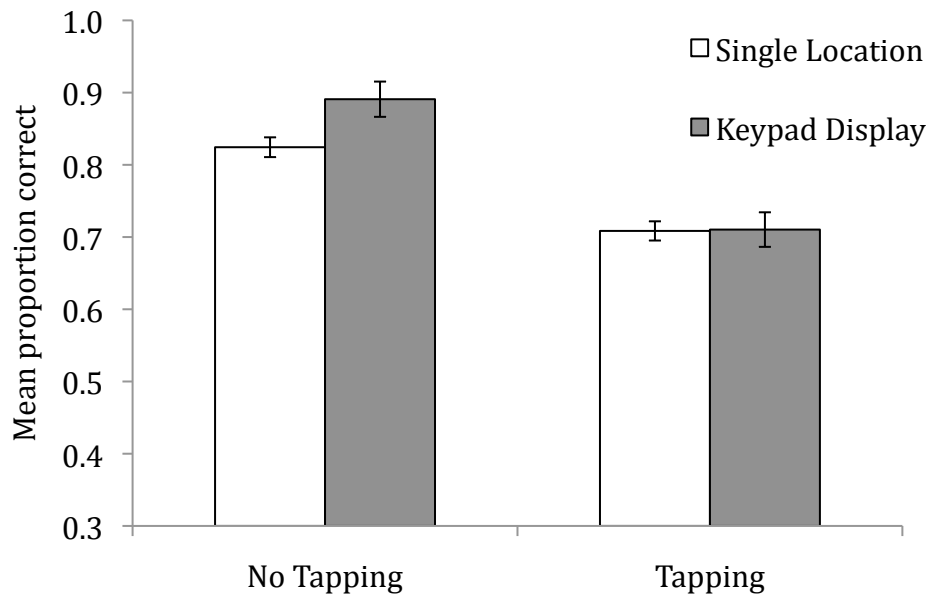

Figure 4

