



UNIVERSITY OF LEEDS

This is a repository copy of *BitTorrent content distribution in optical networks*.

White Rose Research Online URL for this paper:

<https://eprints.whiterose.ac.uk/81233/>

Version: Accepted Version

Article:

Lawey, AQ, El-Gorashi, TEH and Elmirghani, JMH (2014) BitTorrent content distribution in optical networks. *Journal of Lightwave Technology*, 32 (21). pp. 4209-4225. ISSN 0733-8724

<https://doi.org/10.1109/JLT.2014.2351074>

Reuse

Items deposited in White Rose Research Online are protected by copyright, with all rights reserved unless indicated otherwise. They may be downloaded and/or printed for private study, or other acts as permitted by national copyright laws. The publisher or other rights holders may allow further reproduction and re-use of the full text version. This is indicated by the licence information on the White Rose Research Online record for the item.

Takedown

If you consider content in White Rose Research Online to be in breach of UK law, please notify us by emailing eprints@whiterose.ac.uk including the URL of the record and the reason for the withdrawal request.



eprints@whiterose.ac.uk
<https://eprints.whiterose.ac.uk/>

BitTorrent Content Distribution in Optical Networks

Ahmed Q. Lawey, Taisir E. H. El-Gorashi and Jaafar M. H. Elmirghani

School of Electronic and Electrical Engineering, University of Leeds, LS2 9JT, United Kingdom

Abstract—In this paper, we extend our previous study on BitTorrent, the most popular peer-to-peer (P2P) protocol, to investigate different aspects related to its energy efficiency in IP over WDM (IP/WDM) networks, validating the power savings previously obtained by modelling and simulation through experimental results. Our contributions can be summarized as follows: Firstly, we compare the energy consumption of our previously proposed energy efficient BitTorrent protocol to that of the original BitTorrent protocol and the Client-Server (C-S) schemes over bypass IP/WDM networks considering a range of network topologies with different number of nodes and average hop counts. Our results show that for a certain swarm size, the energy efficient BitTorrent protocol achieves higher power savings in networks with lower number of nodes as the opportunity to localise traffic increases. Secondly, we extend our previously developed energy efficient BitTorrent heuristic enhancing its performance by allowing peers to progressively traverse more hops in the network if the number of peers in the local node is not sufficient. Thirdly we extend our previously developed Mixed Integer Linear Programming (MILP) model to optimise the location as well as the upload rates of operator controlled seeders (OCS) to mitigate the performance degradation caused by leechers leaving after finishing the downloading operation. Fourthly, we compare the power consumption of Video on Demand (VoD) services delivered using Content Distribution Networks (CDN), P2P and a promising hybrid CDN-P2P architecture over bypass IP/WDM core networks. A MILP model is developed to carry out the comparison. We investigate two scenarios for the hybrid CDN-P2P architecture: the H-MinNPC model where the model minimises the IP/WDM network power consumption and the H-MinTPC model where the model minimises the total power consumption including the network and the CDN datacenters power consumption. Finally we carry out an experimental evaluation of the original and energy efficient BitTorrent heuristics.

Index Terms—BitTorrent, IP/WDM, power consumption, peer selection, locality, peers behaviour, CDN-P2P

I. INTRODUCTION

The intrinsic goal behind the creation of the Internet was, and still in most applications is, distributing various kinds of content. Therefore, efficient and cost effective content distribution strategies have played a major role in changing the Internet architecture over the years [1]. Several content providers, such as Google, Facebook and YouTube, invest in large datacenters located in diverse geographical locations and connected to high-speed optical networks to meet the ever-increasing demands of content hungry users. However, serious concerns are raised about the power consumption of datacenters [2], leading to significant research efforts being focused on reducing the datacenters power consumption by exploring opportunities inside datacenters [3] and/or optimizing their locations and traffic patterns in the network [4], [5].

On the other hand, Peer-to-Peer (P2P) protocols are emerging

as an efficient content distribution approach [6]. BitTorrent, the most popular P2P protocol, is recognized as a successful P2P system based on a set of efficient mechanisms that overcome many challenges other P2P protocols experience such as scalability, fairness, churn and resource utilization. However, some researchers argue that the BitTorrent fairness mechanism is not very effective as it allows free riders to download more content than they provide to the sharing community. Regardless of the academic concerns, BitTorrent traffic accounts for 17% to 50% of the total Internet upload traffic in some segments [7], [8]. The current BitTorrent implementation is based on random graphs since such graphs are known to be robust [9], yet random graphs mean that BitTorrent is location un-aware which represented a burden on ISPs for many years [10] as traffic might cross their networks unnecessarily causing high fees to be paid to other ISPs.

Existing research on energy aware BitTorrent has focused on the power consumption of both the network side and the peers' side. At the peers' side, studies such as the work in [11] suggested elevating the file sharing task to proxies which distribute the content locally to the clients. In [12] the authors used the result of the fluid model in [13] to study the energy efficiency of BitTorrent in steady state. At the network side, the authors in [14] evaluated the energy efficiency of Client-Server (C-S) and BitTorrent based P2P systems using a simplified model and concluded that P2P systems are not energy efficient in the network side compared to C-S systems due to the multiple hops needed to distribute file pieces between peers. The study suggests that smart peer selection mechanisms might help reduce the number of hops, and consequently the energy consumption. Similar observations are made in [15], [16] where location unawareness doubles the utilization of the access network yielding a higher power consumption. Adding the idle power consumption of the peripherals used for P2P content delivery can double the power consumption in the user's equipments as shown in [17]. However, other researchers in the literature argue that since users of P2P systems only use the already powered on peripherals, only the traffic induced power consumption should be taken into account as in [14]. The authors in [18] studied the performance versus locality trade-offs in BitTorrent like protocols by developing an LP model and a heuristic.

In [19], [20], we investigated the energy consumption of BitTorrent in IP over WDM (IP/WDM) networks considering different IP/WDM approaches. We showed, by mathematical modelling and simulation that peers' co-location awareness, known as locality, helps reduce BitTorrent cross traffic and consequently reduces the power consumption of BitTorrent on the network side, especially for popular content with large number of interested users. Unlike [18], our BitTorrent model takes into account the roles of seeders and leechers, explicitly defines both upload and download capacities, and the peers'

locations refer to the IP/WDM nodes rather than ISPs. In [21], we discussed the impact of leechers' behaviour on the network energy consumption. In [22], we studied the impact of renewable energy availability on BitTorrent traffic in IP/WDM networks. Compared to our contributions in [19] - [22], this paper extends the work by: (i) studying the impact of different physical network topologies on the performance and energy consumption of BitTorrent, (ii) extending the energy efficient BitTorrent (EEBT) heuristic presented in [19] to enhance its performance, (iii) introducing a developed Mixed Integer Linear Programming (MILP) model to optimise the location of operator controlled seeders as well as their upload rate, (iv) investigating the power consumption of a hybrid Content Distribution Networks - Peer to Peer (CDN-P2P) architecture, (v) building an experimental demonstrator which enabled us to demonstrate the performance and energy consumption of the original (OBT) and EEBT and made it possible to verify our models, heuristics and simulations by comparing the experimental results to the theoretical results considering similar peers distributions.

The remainder of this paper is organized as follows. Section II briefly reviews IP/WDM networks and their power minimisation. In Section III we review BitTorrent systems and study the impact of physical network topology on the performance and energy consumption of BitTorrent. Section IV proposes an extended energy efficient BitTorrent heuristic (EEBTv2) and compares its performance to the old heuristic presented in [19]. Section V introduces a new MILP for studying the impact of peers' behaviour where we optimise the location and upload rates of operator controlled seeders. In section VI we investigate the power consumption of a hybrid CDN-P2P network. In Section VII we conduct experimental evaluation of EEBT and compare the results to the MILP model. Finally, Section VIII concludes the paper.

II. IP/WDM NETWORKS

The IP/WDM network consists of two layers, the IP layer and the optical layer. In the IP layer, an IP router is used at each node to aggregate traffic from access networks. Each IP router is connected to the optical layer through an optical switch. Optical switches are connected to optical fiber links where a pair of multiplexers/demultiplexers is used to multiplex/demultiplex wavelengths [23]. Optical fibers provide the large capacity required to connect IP routers. Transponders provide OEO processing for full wavelength conversion at each node. In addition, for long distance transmission, EDFAs are used to amplify the optical signal on each fiber. Fig. 1 shows the architecture of an IP/WDM network.

Two approaches can be used to implement the IP/WDM network, namely, lightpath bypass and non-bypass. In the bypass approach, lightpaths are allowed to bypass the IP layer of intermediate nodes. Implementing such an approach requires intelligence at the optical layer which involves many technical challenges. On the other hand, the forwarding decision in the non-bypass approach is made at the IP layer; therefore, the

incoming lightpaths go through OEO conversion at each intermediate node. The non-bypass approach is implemented in most of the current IP/WDM networks. In addition to the ease of implementation, the non-bypass approach allows operators to perform traffic control operations such as deep packet inspection and other analysis measures.

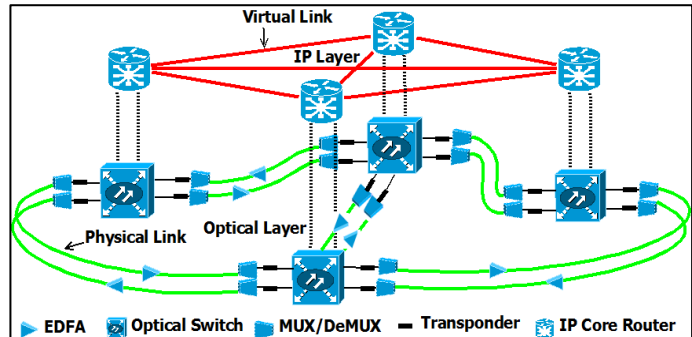

Fig. 1 IP/WDM Network

Energy efficiency of IP/WDM networks is widely investigated in the literature. The authors in [23] have shown that the lightpath bypass approach consumes less power compared to the non-bypass approach as bypassing the IP layer at intermediate nodes reduces the number of router ports, the major power consumers in IP/WDM networks. In [24] the authors focused on reducing the CO₂ emission of backbone IP/WDM networks by minimizing non-renewable energy consumption through introducing renewable energy sources where the traffic is re-routed toward green paths powered by solar cells. They also considered optical bypass and minimum hop routing. In [4] a MILP model is developed to optimise the location of datacenters in IP/WDM networks as a means of reducing the network power consumption. In [25], energy efficient IP/WDM physical topologies are investigated considering different IP/WDM approaches, nodal degree constraints, traffic symmetry and renewable energy availability.

III. BITTORRENT SYSTEMS

A. BitTorrent Overview

In BitTorrent [9], file sharing starts by dividing the file to be shared into small pieces, each of 256 kB typically, by the file owner. The file owner generates a corresponding metadata file, called the torrent file that includes essential information about the shared file to help interested users download it. The torrent file is shared using the HTTP protocol so that users can download it through web pages. The torrent file directs users to a central entity, called the tracker which monitors the group of users currently sharing the content. Such groups are referred to as swarms in BitTorrent terminology and their members as peers. Peers in a swarm are divided into seeders and leechers. Seeders have a complete copy of the file to be shared while leechers have some or none of the file pieces. When contacted by leechers, the tracker returns a list of

randomly chosen peers. Leechers select a fixed number of other interested leechers to upload a piece to after the leecher finishes downloading that piece. This selection process, known as the choke algorithm, is the central mechanism of BitTorrent. Each leecher updates its selection every 10 seconds to select the four peers offering it the highest download rates. On the other hand, seeders select leechers based on their download rates or in a round robin fashion [26]. Tit-for-Tat (TFI) is another implemented mechanism that guarantees fairness by not permitting peers to download more than they upload to other peers.

The BitTorrent protocol employs other mechanisms to ensure its stability and performance such as the piece selection strategy, implemented by the Local Rarest First (LRF) algorithm, where leechers seek to download the least replicated piece first. The experimental study in [26] has shown that LRF ensures a good replication of pieces in real torrents. An optimal LRF ensures the availability of interested pieces that peers can always find to download from each other. Another mechanism is the optimistic unchoke algorithm that enables recently arriving peers to download their first piece and allows existing peers to discover better candidates in terms of the download rates they offer.

As stated earlier, BitTorrent randomness in peers selection where they select each other randomly regardless of the impact on the underlying network represents a major concern. For instance, a seeder in a certain ISP network might unchoke a remote leecher in another ISP while overlooking a nearby leecher located in the same ISP. This generates network cross traffic which results in extra fees to be paid to the other ISP. Such behaviour is referred to as location un-awareness. Several studies proved that employing locality in peer selection, i.e., prioritizing nearby peers over far ones, can reduce ISP cross traffic while maintaining acceptable performance for BitTorrent [10]. Service support through Nano-datacenters (Nada) has been shown to benefit from location awareness in BitTorrent managed networks [27].

We developed a MILP model to study the impact of peer selection on the power consumption of BitTorrent [19], [20] over bypass and non-bypass IP/WDM networks. In that model peers' locations refer to nodes in the IP/WDM network rather than ISPs Autonomous Systems, i.e. the model tries to minimize traffic between nodes. The objective function of the model considered maximizing the download rate while the network power consumption is minimized. We assumed optimal LRF, where peers always have interesting file pieces. We also assumed a flash crowd scenario for BitTorrent, the most challenging phase for content providers [10], where the majority of leechers arrive soon after a popular content is shared. For simplicity, we did not consider optimistic unchoke in the MILP model. In this work we also use these assumptions for the parts dealing with model analysis.

B. MILP Model Results

In [19] we compared the EEBT with the original implementation of BitTorrent (OBT) and Client-Servers (C-S) systems considering the NSFNET as an example network.

Our results in [19] indicate that OBT protocol, based on random peer selection, is energy unaware and therefore has similar energy consumption on the network side compared to a typical C-S model considering similar delivery scenarios. However, the EEBT protocol we introduced, which exploits locality, can reduce the energy consumption of BitTorrent in IP/WDM networks by 30% and 36% compared to the C-S scheme under the bypass and non-bypass approaches, respectively, while maintaining the optimal download rate. Investigating the behaviour of our EEBT model shows that the model converges to locality where peers select each other based on their location rather than randomly. In Fig. 2 we show a visualisation of the selection matrix U_{ijk} ($U_{ijk} = 1$ if peer i unchokes peer j in swarm k , otherwise $U_{ijk} = 0$) for a single swarm of 30 seeders and 70 leechers in the NSFNET network. The red dots in the graph represent peers. It is obvious that peer selection in OBT is random, as peers have no sense of location; therefore, a peer might select a far peer while neglecting a nearby one. Examining the peer selection for the energy aware BitTorrent, we notice that peers favour peers who are near in terms of number of hops as fewer hops yield lower power consumption.

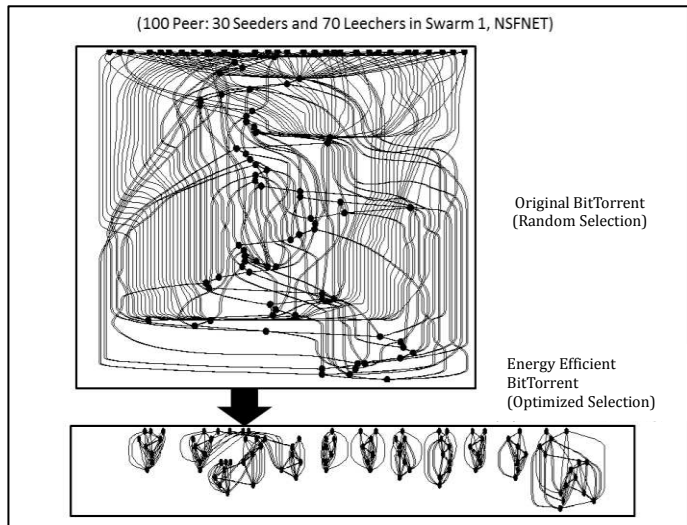

Fig. 2 Peers Selection Matrix U_{ijk}

In this section we study the impact of the network topology on the energy efficiency of BitTorrent over bypasses IP/WDM networks. We consider three topologies of different number of nodes and average hop counts, namely, the AT&T network in USA, the British Telecom network in Europe (EU BT), and the Italian network.

In [19] we considered the same content distribution scenario for the different schemes (BitTorrent and C-S schemes) over the NSFNET topology where 160,000 groups of downloaders, each

downloading a 3 GB file, are distributed randomly over the network nodes. Each group consists of 100 members.

For the BitTorrent scenario, we refer to the downloader groups as swarms and their members as peers. Each swarm has 100 peers. We considered a homogeneous system where all peers have an upload capacity of 1Mbps. This capacity reflects typical P2P users in the Internet [28]. The average regular traffic demand between each node pair in the NSFNET considering different time zones is 82 Gbps [4]. The aggregate BitTorrent traffic is 16 Tbps, however some peers communicate with peers in their own node. Therefore the aggregate BitTorrent traffic that contributes to cross-node traffic is 14.9 Tbps which corresponds to an average node-to-node BitTorrent traffic of 82 Gbps. The scenario we considered represents a future scenario with approximately double the current level of network traffic. Note that traffic is currently growing at 30%-40% per year [29] and therefore doubles every two years approximately.

To study the performance over the different topologies, we estimate the average regular traffic between node pairs, ART_n , based on the traffic of the NSFNET topology:

$$ART_n = \left(\frac{P_n}{P_{NSFNET}} \right) \cdot ART_{NSFNET} \text{ Gbps} \quad (1)$$

where P_n is the population of users in topology n and P_{NSFNET} , is the population of users in the NSFNET which is considered to be equal to the USA population, ART_{NSFNET} is the average regular traffic demands between node pairs in NSFNET (Table I). We use ART_n to generate the elements of the regular traffic matrix, denoted as RTN_{sd} , randomly and uniformly distributed between $[10, (2 \cdot ART_n - 10)]$ Gbps.

The number of swarms, NS_n , is calculated based on the fact that the total swarm traffic should be equal to the total regular traffic so that each contribute 50% of the total traffic in the network. Solving the MILP model on a PC does not scale to produce results for a large network. Therefore in [19] to define a tractable problem, we solve the model for 20 swarms and assume that the network contains 8k replicas of these 20 swarms, i.e. a total of 160k swarms so the swarms contribute 50% of the total traffic in the network. To obtain the total number of swarms for each of the topologies considered in this study, the 20 swarms are scaled by the ratio between the total regular traffic and the total swarms' traffic. So NS_n is given as:

$$NS_n = 20 \cdot \left(\frac{\sum_{s \in N} \sum_{d \in N} RTN_{sd}}{\sum_{s \in N} \sum_{d \in N} STN_{sd}} \right) \quad (2)$$

where STN_{sd} is the swarms traffic between nodes s and d due to running the OBT model with 20 swarms. The resulting regular traffic and number of swarms are summarized in Table I.

For the C-S scheme, the model in [4] is used to optimally locate 5 datacenters in the different topologies and evaluate the performance of the C-S scheme. Note that we assume different data centres have different content, i.e. content is not replicated,

and all the content is equally popular. For fair comparison, the number of downloaders in the C-S scenario is assumed to be equal to the number of leechers in the BitTorrent scenario, and seeders are replaced by five datacenters with an upload capacity equal to the total upload capacity of all peers in the BitTorrent scenario. This ensures that the upload capacity and download demands are the same for both scenarios and therefore, the power consumption will only depend on how the content is distributed.

The results are obtained against increasing number of seeders (from 25 to 95) in steps of 10 where the number of leechers decreases accordingly to maintain the total number of peers in all cases at $PN = 100$ peers (Table II). For instance, if the number of seeders is 55 in a figure, this means that the number of leechers is 45. Power savings are calculated at each number of seeders case and eventually averaged over the whole range to obtain the average power savings as increasing/decreasing number of seeders/leechers represents a scenario where leechers turn gradually into seeders after finishing downloading the file.

TABLE I. ANALYZED NETWORKS INFORMATION

Network	Country	Population (Million)	No. of Nodes	No. of Links	Avg. Hop Count	Avg. Regular Traffic (Gbps)	No. of Swarms
NSFNET	USA	314	14	21	2	82	160,000
AT&T	USA	314	25	54	2.5	82	509,400
EU BT	Europe	406	21	34	2	105.8	464,740
Italian	Italy	61	21	36	3	15.9	70,000

Table II displays the input parameters to the models [19].

TABLE II
INPUT DATA FOR THE MODELS

Power consumption of a router port (Prp)	1000 W [30]
Power consumption of transponder (Pt)	73 W [23]
Power consumption of an optical switch (PO_i) $\forall i$	85 W [31]
Power consumption of EDFA (Pe)	8 W [32]
Power consumption of a Mux/Demux (Pmd)	16 W [33]
No. of wavelengths in a fiber (W)	16
Bit rate of each wavelength (B)	40 Gbps
Span distance between EDFAs (S)	80 km
Number of modeled swarms (SN)	20
Number of peers in single swarm (PN)	100
Number of upload slots (SLN)	4
Upload capacity for each peer (Up)	0.001 Gbps
Download capacity for each peer (Dp)	0.01 Gbps
Number of datacenters (DCN)	5
Factor of average download rate (α)	1,000,000
Factor of power consumption (β)	0 or 1

B.1 AT&T Network:

The AT&T network [34], [35] projected on USA map [36], shown in Fig. 3, consists of 25 nodes and 54 bidirectional links. As the AT&T network is located in USA; it is considered to have the same population and average regular traffic between node pairs as the NSFNET. However, due to its higher number of nodes compared to the NSFNET, the total regular traffic in this network will be higher. Therefore, 509,400 swarms are assumed for this network as shown in Table I. The 5 data centres of the C-S system are optimally located at nodes 11, 13, 14, 17 and 24 to minimise power consumption using our data centres MILP in [4].

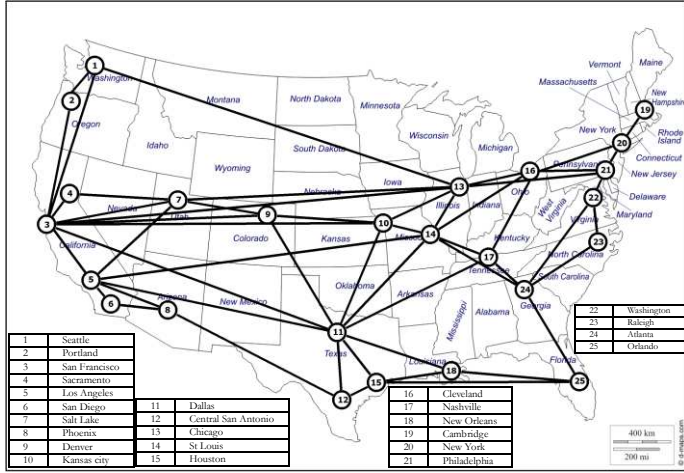

Fig. 3 AT&T Network [34], [35], [36]

Fig. 4 compares the performance of the original BitTorrent (OBT), Energy Efficient BitTorrent (EEBT) and Client Server (C-S) schemes over the AT&T network. Similar trends to those observed for the NSFNET network [19] are observed for the AT&T network. Fig. 4(a) shows that the three schemes: OBT, EEBT and C-S achieve the optimal download rates. However, they consume different amounts of power as shown in Fig. 4(b). The OBT scheme has the highest power consumption as it yields the highest cross traffic between nodes due to its locality unawareness. The C-S scheme consumes slightly less power compared to the OBT as downloaders consume no power in the core network when they download from a local datacenter in their node, yielding 1% power saving compared to the OBT. The EEBT scheme is the most energy efficient scheme among the schemes considered as it considers the peers' locations, resulting in 19% power saving compared to the OBT scheme. The lower power saving achieved by the EEBT scheme over the AT&T (19%) network compared to the savings over the NSFNET (30%) [19] is due to the higher number of nodes which leads to having a smaller number of localized peers per node, hence, higher likelihood that leechers connect with peers across the network to achieve the optimal download rate [37]. As noticed in [19], the decline in power consumption at 95 seeders is because the remaining 5 leechers only require a total download rate of 0.05 Gbps due to their download capacity limit which can be satisfied

by only 50 peers (the 5 leechers plus 45 seeders out of the 95 seeders) in the BitTorrent scheme, resulting in 50% lower P2P upload traffic in the network and consequently lower power consumption as shown in Fig. 4(b). For C-S scheme the servers will push less traffic as well to satisfy the lower demanded traffic by the 5 downloaders.

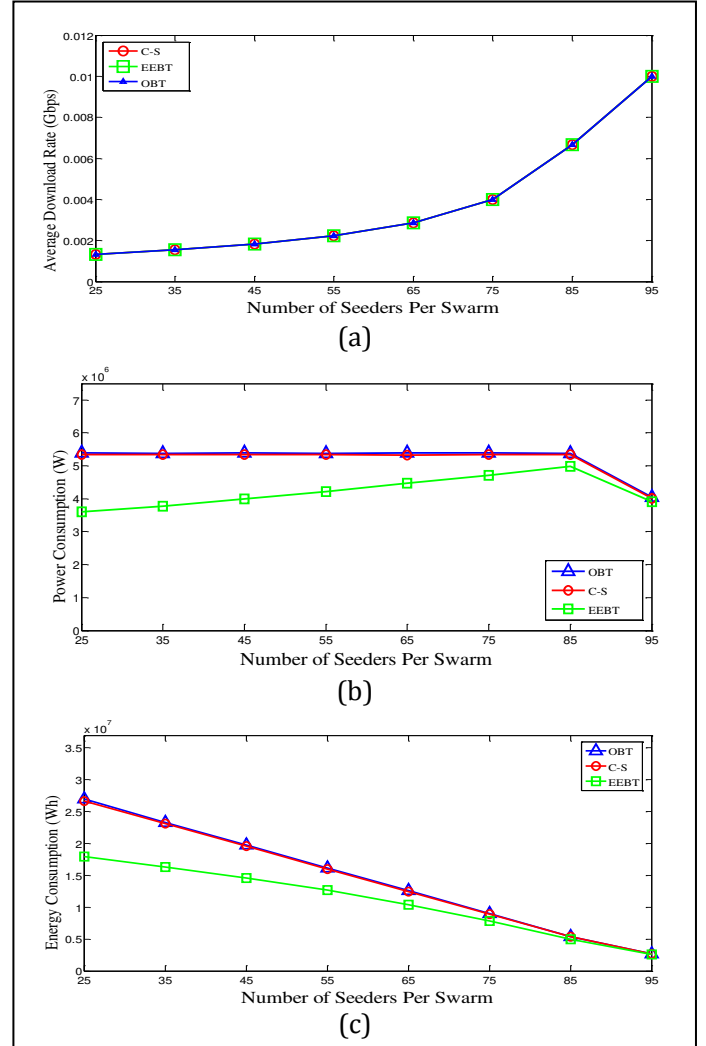

Fig. 4 AT&T Network Results (a) Download rate (b) IP/WDM Power Consumption (c) IP/WDM Energy Consumption

To evaluate the energy consumption under a particular number of seeders, we multiplied the power consumption by the average download time (calculated by dividing the file size by average download rate). As all schemes achieve similar download rates, the energy consumption, shown in Fig. 4(c), displays similar trend as the power consumption. Note that Fig 4b (power) shows a sudden drop, while Fig 4c (energy) does not. This is due to the download capacity limit of 10 Mbps per peer which reduces the download rate for the 5 leechers from 20 Mbps to 10 Mbps; (At 95 seeders (i.e. 5 leechers)), the average download rate per leecher should be $100 \times 1\text{Mbps}/5 = 20 \text{ Mbps}$ which is double the download capacity per leecher ($D_p = 10 \text{ Mbps}$, table II)). This

means that the power at 95 seeders is multiplied by a longer time duration, (0.67 hours rather than 0.33 hours), due to the lower download rate and consequently this slopes the energy curve up compared to other cases and prevents the reproduction of the drop in power consumption curve.

B.2 British Telecom European Network (EU BT):

The EU BT Network [34], [38] projected on the map of Europe [39], depicted in

Fig. 5, has 21 nodes and 34 bidirectional links. The total population of the cities covered by this network is higher than that of the NSFNET, therefore, higher average regular traffic and number of swarms is considered for this network as shown in Table I. The 5 data centres of the C-S system are optimally located at nodes 1, 4, 6, 8 and 12 to minimise the power needed.

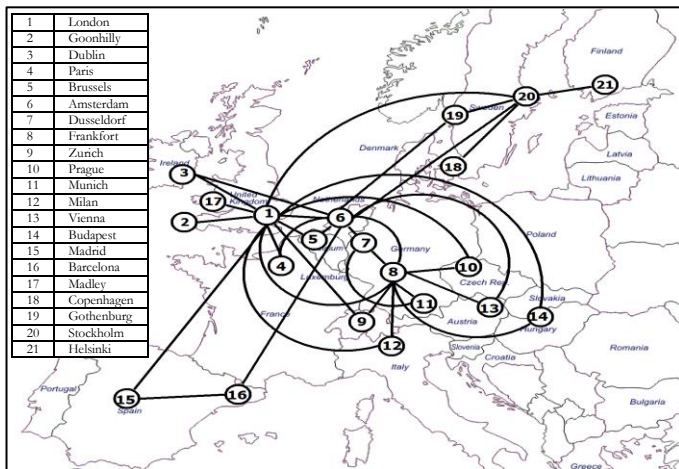

Fig. 5 EU BT Network [34], [38], [39]

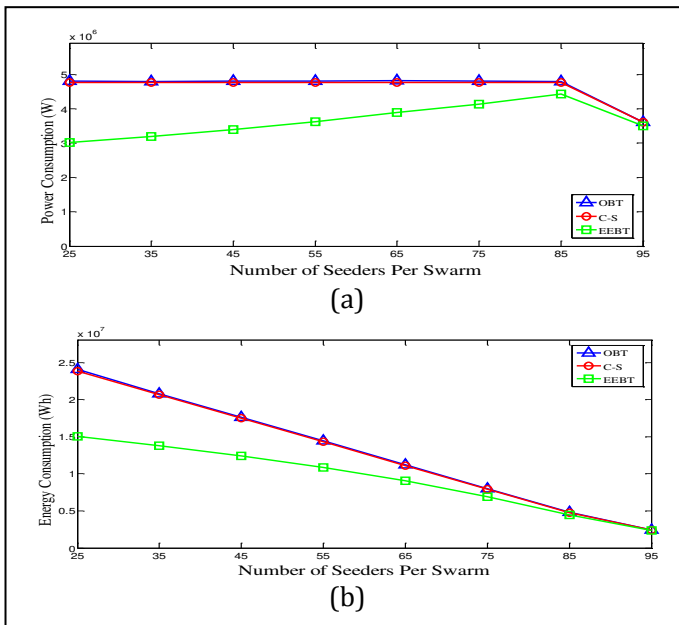

Fig. 6 EU BT Network Results (a) IP/WDM Power Consumption (b) IP/WDM Energy Consumption

Fig. 6 displays the EU BT network power and energy consumption. The average download rate exhibits similar values to those in Fig. 4(a) since the physical topology has no impact on the optimal download rate. Fig. 6(a) reveals that EEBT saves 21% of the network power consumption compared to the OBT. The slightly higher power saving compared to the power savings achieved by the EEBT scheme over the AT&T network is due to the lower number of nodes in the EU BT network, and hence, higher average number of peers per node which increases the ability to localise traffic within the same node.

B.3 Italian Network:

The Italian network [34][40] projected on Italy map [41], shown in Fig. 7, consists of 21 nodes and 36 bidirectional links. It has the lowest population among the analyzed networks, leading the lowest regular traffic and number of swarms as shown in Table I. We consider the C-S system with 5 datacenters located optimally at nodes 9, 12, 13, 14, and 15.

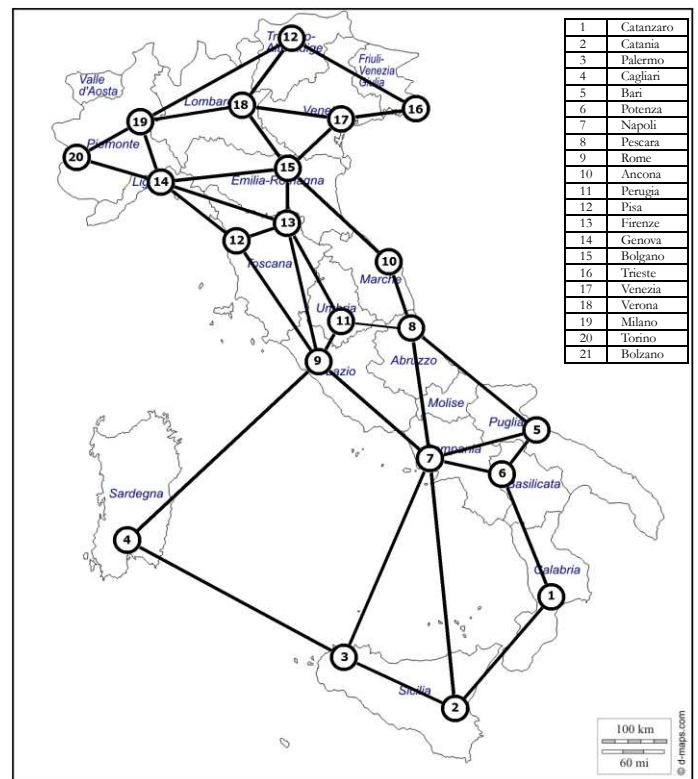

Fig. 7 The Italian Network [34],[40], [41]

As explained above in section B2, the average download rate is the same as that observed in Fig. 4(a) as peers download rate is independent of the physical topology considered. Fig. 8 reveals that EEBT achieves 22% power and energy savings compared to the OBT scheme. This saving is slightly higher compared to the savings over the EU BT network despite the fact that both networks have similar number of nodes. This is due to the higher average hop count of the Italian network (3 hops) compared to the EU BT network (2 hops) which increases the power consumed by the transponders and multiplexers/demultiplexers

(both consume more power with respect to EDFA). Therefore locality in the Italian network will yield higher reduction in the number of utilized transponders and multiplexers/demultiplexers compared to the EU BT network. More saving is expected for non-bypass IP/WDM approach where the number of router ports, the most power consuming devices in the network, is a function of the hop count.

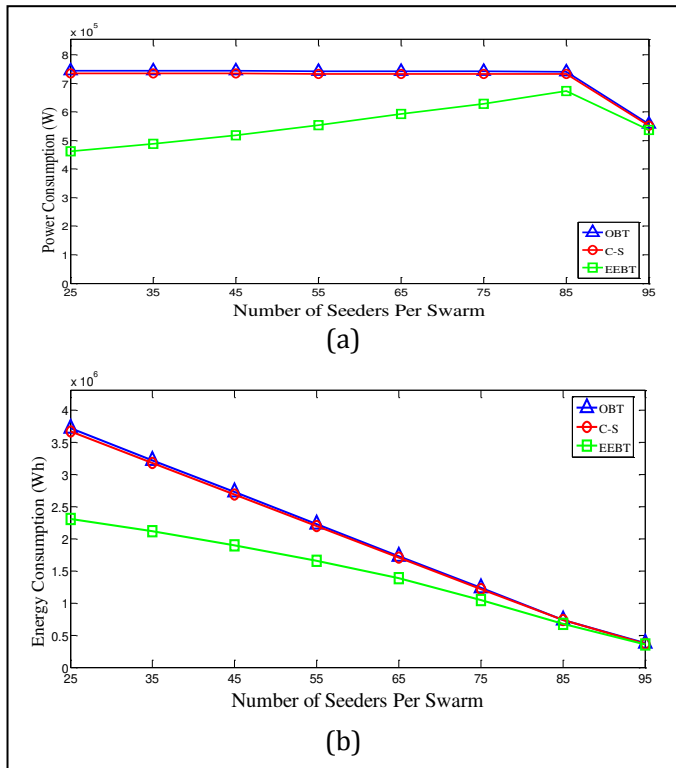

Fig. 8 Italian Network Results (a) IP/WDM Power Consumption (b) IP/WDM Energy Consumption

We finally conclude that the size of the network in terms of number of nodes and the average hop count are the main drivers for power saving in localized BitTorrent P2P protocols. Smaller networks with higher average hop counts yield more saving when comparing OBT and C-S for a given swarm with certain number of peers.

IV. ENHANCED ENERGY EFFICIENT BITTORRENT HEURISTIC (EEBTv2)

Investigating the results of the energy efficient BitTorrent model (EEBT) shows that the majority of peers selected by any leecher are located within the leecher local node to minimise energy consumption as spanning the neighbouring nodes can increase the power consumption of the network unnecessarily. Such localized selection did not affect the achieved average download rates. The TFT mechanism ensures that the download rate a leecher gets from other leechers is limited to its upload capacity. Therefore, as all leechers are assumed to have the same upload capacity, spanning to peers in neighbouring nodes does not grant leechers higher download rates than what they can

achieve from leechers in the local node as long as a sufficient number of leechers (at least 5 leechers, including the leecher itself, (in the BitTorrent protocol a leecher is allowed to connect to a maximum of 4 peers)) are available in the local node. The results also reveal that seeders may select remote leechers (when there is an insufficient number of local leechers) to help them maintain their optimal download rate. In [19] we developed an energy efficient BitTorrent (EEBT) heuristic based on the above observations.

However, the heuristic in [19] is a one hop heuristic, meaning that leechers and seeders can search for other leechers in a maximum of one hop distance. In this section we enhance the performance of the EEBT heuristic by allowing leechers to extend their selection beyond the local or neighbourhood nodes when the number of peers in their search area falls below the number of upload slots ($SLN = 4$).

To implement such heuristic, leechers need to have full knowledge of the distribution of other leechers in the network which can be provided by the tracker. We define a parameter called **Radius** that can have a value between 0 and the maximum number of hops in the network (MH) where $Radius = 0$ refers to the local node. Each peer i in swarm k create a list, $D(i, k, r)$, which contains the other leechers that are located in the nodes that lie within $Radius \leq r$. For instance, for $Radius = 1$, a leecher in node 1 will list all the other leechers that belong to the same swarm located in node 1, 2, 3 and 4, as nodes 2, 3 and 4 are one hop neighbours of node 1. We refer to the enhanced heuristic as Enhanced Energy Efficient BitTorrent (EEBTv2).

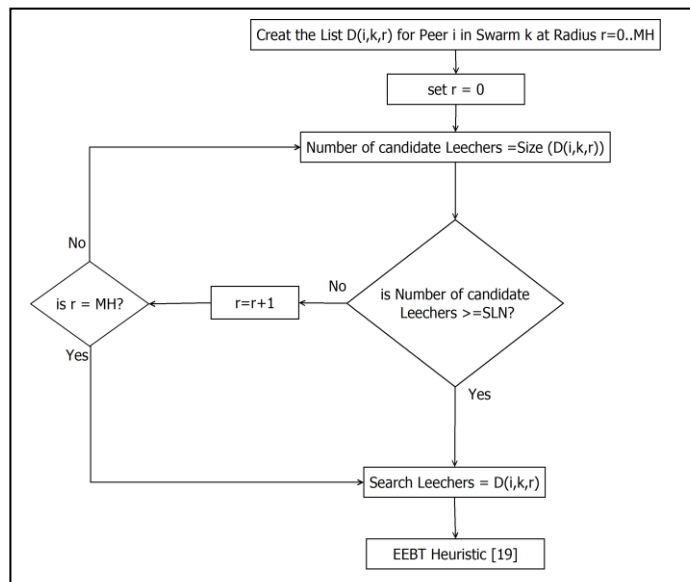

Fig. 9 The Flowchart of the EEBTv2 Heuristic

Fig. 9 shows the flowchart of the EEBTv2 heuristic, leechers search for other leechers to unchoke by searching in progressive values of **Radius** until enough leechers are found. This ensures that each leecher will have at least SLN leechers to TFT with.

Fig. 10 compares the performance of the EEBTv2 heuristic to the EEBT and OBT heuristic over the NSFNET network. The EEBTv2 heuristic achieves a download rate comparable to that of the OBT heuristic as shown in Fig. 10(a) which is a rate higher than that achieved by the EEBT of [19]. To achieve such download rate, leechers in the EEBTv2 heuristic have to traverse more hops to connect to other leechers compared to the EEBT heuristic, reducing the power consumption saving achieved compared to the OBT heuristic from 29% achieved by the EEBT heuristic [19] to 11%, as shown in Fig. 10(b).

Because of the high download rate achieved by the EEBTv2 heuristic, the difference in energy consumption between the two heuristics is reduced. While the EEBT heuristic saves about 17% energy compared to the OBT, the EEBTv2 heuristic achieves 11% energy savings as shown in Fig. 10(c). At high number of seeders (corresponding to low number of leechers) the EEBTv2 heuristic, Fig. 10(c), consumes lower energy compared to the EEBT as the download rate of the EEBT is degraded by 13% in this case [19].

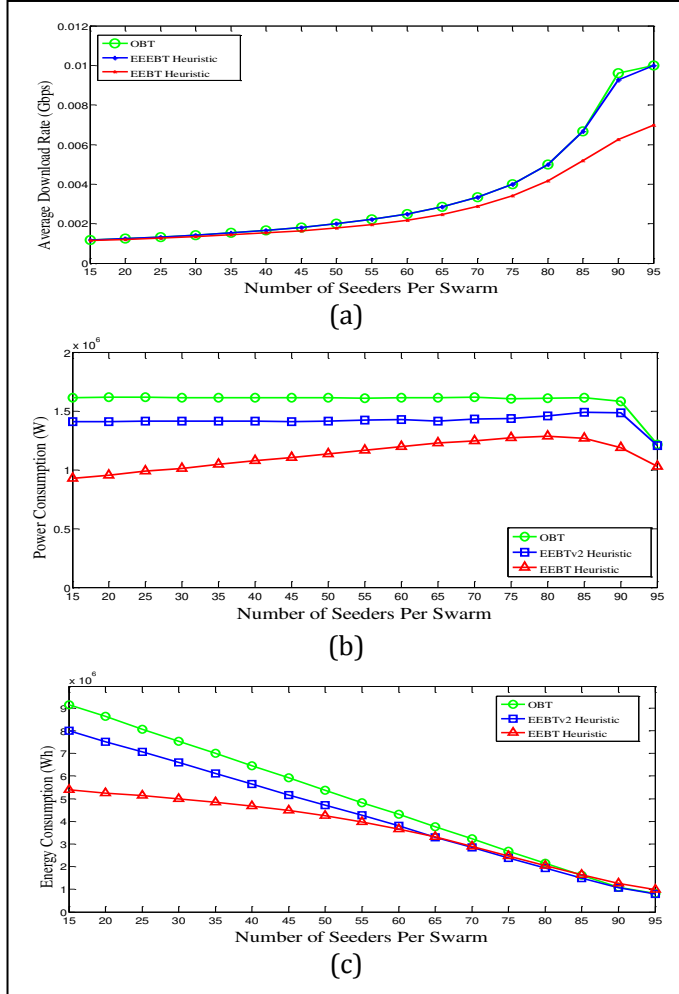

Fig. 10 The performance of the different BitTorrent Heuristics (a) Average Download Rate (b) IP/WDM Power Consumption (c) IP/WDM Energy Consumption

V. IMPACT OF LEECHERS BEHAVIOUR

A. Overview

In the previous section we assumed a flash crowd scenario where all peers arrive to the network to download a particular popular shared content and therefore they all finish almost at the same time as the peers are homogenous in terms of their upload capacity. However, peers might arrive in the network at different points in time and therefore they finish at different times. After they finish downloading their files, leechers might stay to seed or they might leave the network as they do not have an incentive to participate in sharing their files.

In [21], we compared the network performance and energy consumption under two scenarios. In the first scenario leechers stay to seed after finishing downloading while the second scenario assumes leechers leave the network as soon as they finish downloading. We fixed the number of seeders (original seeders) and decreased the number of leechers from 85 to 5 leechers. Our results indicated that with 15 original seeders, EEBT consumes 61% more energy when leechers leave the network after finishing downloading compared to the scenario where leechers stay to seed after finishing downloading. We also proposed the introduction of operator controlled seeders (OCS) to compensate for the impact of leechers' departure on the energy consumption. Considering U_{ijk} as an input parameter ($U_{ijk} = 1$ if peer i unchokes peer j in swarm k , otherwise $U_{ijk} = 0$), we developed a model to maintain the download rate by optimising the OCS upload rate.

In this section we extend the work in [21] to further optimise the location of OCS as well as their upload rate in case leechers start to leave the network after finishing downloading.

B. MILP For OCSs Location & Upload Rate Optimisation

Before introducing the extension of the model in [21], we define the necessary, parameters and variables:

Parameters:

N	Set of IP/WDM nodes
Sw	Set of swarms
P_k	Set of peers in swarm k
S_k	Set of OCS in swarm k
L_k	Set of leechers in swarm k
SN	Number of swarms
PN	Number of of peers in a single swarm
LN	Number of leechers in a single swarm
SLN	Number of upload slots
Up	Upload capacity of each leecher
SR	Upload rate for each slot, $SR = Up/SLN$
Dp	Download capacity of each peer

Variables

U_{ijk}	$U_{ijk}=1$ if peer i unchokes peer j in swarm k , otherwise $U_{ijk}=0$
$Avdr_{ik}$	Download rate of leecher i that belongs to swarm k
US_{isjk}	The upload traffic sent from the OCS i in node s to leecher j , where both the OCS and the leecher are in swarm k
USb_{isjk}	$USb_{isjk} = 1$ if OCS i in node s unchokes leecher j , where both the OCS and the leecher are in swarm k , otherwise $USb_{isjk} = 0$
SL_{isk}	$SL_{isk} = 1$ if OCS i is located in node s in swarm k , otherwise $SL_{isk} = 0$

Objective: Similar to the objective of the model in [21].

Subject to:

$$Avdr_{jk} = \sum_{i \in L_k: i \neq j} SR \cdot U_{ijk} + \sum_{i \in S_k} \sum_{s \in N} US_{isjk} \quad \forall k \in Sw \quad \forall j \in L_k \quad (3)$$

$$US_{isjk} \cdot M1 \geq USb_{isjk} \quad \forall k \in Sw \quad \forall i \in S_k \quad \forall j \in L_k \quad \forall s \in N \quad (4)$$

$$US_{isjk} \leq M2 \cdot USb_{isjk} \quad \forall k \in Sw \quad \forall i \in S_k \quad \forall j \in L_k \quad \forall s \in N \quad (5)$$

$$\sum_{j \in L_k} USb_{isjk} \geq SL_{isk} \quad \forall k \in Sw \quad \forall i \in S_k \quad \forall s \in N \quad (6)$$

$$\sum_{j \in L_k} USb_{isjk} \leq M \cdot SL_{isk} \quad \forall k \in Sw \quad \forall i \in S_k \quad \forall s \in N \quad (7)$$

$$\sum_{s \in N} SL_{isk} = 1 \quad \forall k \in Sw \quad \forall i \in S_k \quad (8)$$

$$\sum_{s \in N} \sum_{j \in L_k} USb_{isjk} \leq SLN \quad \forall k \in Sw \quad \forall i \in S_k \quad (9)$$

$$US_{isjk} \geq SR \cdot USb_{isjk} \quad \forall k \in Sw \quad \forall i \in S_k \quad \forall j \in L_k \quad \forall s \in N \quad (10)$$

$$\frac{1}{LN \cdot SN} \cdot \sum_{k \in Sw} \sum_{i \in L_k} Avdr_{ik} \leq Up + \sum_{s=1}^{PN-LN} Up / LN \quad (11)$$

$$\sum_{s \in N} \sum_{j \in L_k} US_{isjk} \leq Dp \quad \forall k \in Sw \quad \forall i \in S_k \quad (12)$$

Constraint (3) calculates the total download rate for each leecher by summing the download rates the leecher obtains from other leechers and OCSs. Constraints (4) and (5) determine whether the OCS i in node s unchokes leecher j in the same swarm k . $M1$ and $M2$ are large enough numbers with units of 1/Gbps and Gbps, respectively, and they ensure that $USb_{isjk} = 1$ if $US_{isjk} > 0$, otherwise $USb_{isjk} = 0$. Constraints (6) and (7) determine the location of OCS i in swarm k . M is a large enough unitless number that ensures $SL_{isk} = 1$ if $\sum_{j \in L_k} USb_{isjk} > 0$, otherwise $SL_{isk} = 0$. Constraint (8) ensures that there is only one copy of each OCS in the network. Constraint (9) limits the total number of upload slots of OCSs to the maximum allowed number of upload slots, defined by SLN . Constraint (10) ensures that the upload rate for each slot for OCSs is not less than the defined slot rate for leechers (SR). However, OCSs are allowed to increase their upload slots rates beyond SR . Constraint (11) ensures that the average download rate for all leechers equals to the optimal download rate. This will force the OCSs to increase their upload rate in case leechers leave the network after finishing downloading. Constraint (12) limits the maximum upload rate for OCSs to their download capacity as it is unrealistic to have a peer with more upload capacity than its download capacity.

C. MILP Model Results

Our evaluation is based on the assumption that leechers arrive to the network in groups, each of 10 leechers, at different time intervals until the total number of leechers reaches 85. Therefore, at a certain time, each group would have downloaded a different percentage of the file depending on their arrival time. We also assume that the arrival behaviour results in a linear relationship between group index and the downloaded percentage of the file [21].

Fig. 11 compares the performance of the energy efficient BitTorrent (EEBT) model, where OCS are optimally located, to the results of the three schemes considered in [21] where (i) leechers stay, (ii) leechers leave with no OCS, and (iii) uniformly distributed OCS compensate for the reduction in the download rate after leechers leave. The different schemes are compared in a scenario where the swarm has 15 OCS and 85 leechers, leechers finish downloading in groups of 10 and either leaves the network or stay to act as seeders. Fig. 11(a) shows that optimally locating the OCS nodes achieved similar download rate to the case of leechers staying. Moreover, the new scheme saves 15% and 40% power consumption compared to the scheme where leechers stay and leechers leave and no OCS are introduced, respectively as shown in Fig. 11(b). This is because the new scheme, unlike the uniform distribution of OCS where some nodes might end up with no OCS, place an OCS in each node which minimises the cross traffic due to OCS to leechers selections. Note also that the

scenario of leechers leaving with no OCS has the highest energy consumption in spite of the fact that it does not have the highest power consumption. This is because this scenario has the lowest download rate (Fig. 11a) as leaving peers are not replaced by OCS and the swarm loses upload capacity and consequently low download rates and high download times are observed. This eventually leads to high energy consumption as shown in Fig. 11c.

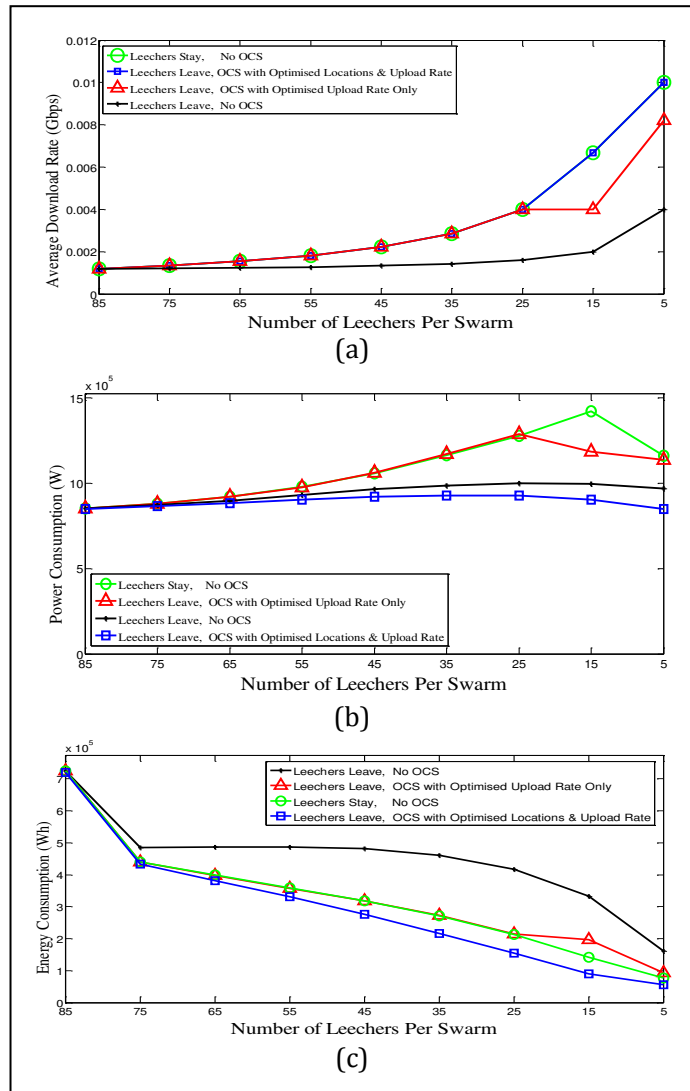

Fig. 11 MILP results for OCS (a) Average Download Rate (b) IP/WDM Power Consumption (c) IP/WDM Energy Consumption

VI. HYBRID CDN-P2P ARCHITECTURE

In the previous sections we have compared P2P and C-S systems in terms of energy efficiency. We showed that location aware BitTorrent systems can achieve significant energy savings compared to C-S systems. However, BitTorrent systems will suffer in an environment where the content availability is scarce or far. In this section we study a hybrid Content Delivery Network - Peer-to-Peer (CDN-P2P) [42] architecture as an efficient solution for content distribution in terms of cost and

performance as it inherits the stability of CDN and scalability of P2P. In such systems, users basically connect to each other in a P2P fashion to exchange data with the aid of the CDN datacenters in case the P2P network throughput is not enough to meet the data rate required by the service quality measure. One of the promising applications for this architecture is video streaming and in particular Video on Demand (VoD). A number of papers analyzed the performance of CDN-P2P architectures in terms of the end users' perceived data rate [43], [44], [45] and they all concluded that it is a potential scheme in terms of cost, capacity and robustness as it effectively inherits the advantages of both the P2P and CDN architectures. However, little attention has been paid to the power consumption of CDN-P2P architectures at the network side and inside the datacenters. The authors in [46] have evaluated a hybrid P2P (HP2P) architecture where videos are delivered from the CDN datacenters or from neighbouring set-top boxes if the video is available in the local community. They also suggested a localized peer assisted patching (PAP) with multicast delivery for highly popular content where newly arrived requests are assigned to the last multicast session while getting the first parts of the video from neighbouring peers who joined early. Both schemes outperform CDN delivery energy efficiency with PAP being more energy efficient than HP2P for popular content and vice versa.

The authors in [47] developed heuristics to analyse the energy efficiency of the hybrid CDN-P2P architecture in IP/WDM networks taking into account content popularity, number of requests, and peer content sharing duration where they demonstrated 20-40% energy savings for moderately popular content.

In this section, we develop a MILP to study and optimize the energy efficiency of a hybrid CDN-P2P architecture where peers can download a video from other peers using a P2P BitTorrent like protocol and/or from a CDN datacenter if the P2P capacity is not enough to deliver the video at the required streaming rate. Unlike HP2P in [46] and the heuristics in [47], our CDN-P2P model allows each peer to download from multiple sources (P2P and/or CDN) simultaneously which requires the servers to be BitTorrent aware as peers will ask these servers for specific pieces of data identified in the metadata file rather than the complete content. The fraction of sources that share content using the P2P protocol are constrained by TFT as in the OBT implementation. We model servers power consumption in CDN datacenters while the work in [47] considers the Ethernet switches and edge routers of a fat tree based datacenters architecture. The authors in [46] assume a fixed core hop count of 4 while peers in our model, similar to [47], can access datacenters at different hop counts. It should be noted however that unlike our work, [47] is not a BitTorrent network in that peer swarms are not formed (such swarms may constrain or support the peer performance according to situation), a file is not broken into pieces for sharing, the BitTorrent TFT mechanism is not implemented, [47] assumes download from a single source who is able to provide the full rate, while BitTorrent specifies download from multiple peers so that the TFT reward mechanism leads to stability (also rewards) and a

distributed P2P system. We address these points in our MILP, and furthermore our heuristics and experimental demonstration implement the (BitTorrent mechanisms) and optimal local rarest first mechanism which ensures that the peers have interesting pieces to download.

A. MILP FOR CDN-P2P SYSTEMS

In this section we extend the model developed in [19] to consider CDN-P2P hybrid architecture. In the hybrid model, a peer can receive a video by joining a particular swarm that is currently participating in sharing that video and/or from a datacenter in case the P2P network capacity is not sufficient to deliver the video with the required streaming rate.

In addition to the sets, parameters and variables previously defined, the following sets, parameters and variables are defined:

Parameters:

DC	Set of nodes with datacenters
Nm_i	Set of node i neighbors
Pn_{ik}	Set of peers of swarm k located in node i
Prp	Power consumption of a router port
Pt	Power consumption of a transponder
Pe	Power consumption of an EDFA
PO_i	Power consumption of the optical switch in node i
Pmd	Power consumption of a multi/demultiplexer
A_{mn}	Number of EDFAs between node pair (m,n)
L_r^{sd}	Regular traffic demand between node pair (s,d)
VSR	Video streaming rate
Epb	Energy per bit for the server
δ_s	$\delta_s = 1$ if node s has a datacenter, otherwise $\delta_s = 0$

Variables

C_{ij}	Number of wavelengths in the virtual link (i,j)
L_{ijk}^{sd}	Swarm k traffic demand between node pair (s,d) traversing virtual link (i,j)
L_{ij}^{sd}	The regular traffic flow between node pair (s,d) traversing virtual link (i,j)
W_{mn}	Total number of wavelengths in the physical link (m,n)
F_{mn}	Total number of fibers on the physical link (m,n)
Q_i	Number of aggregation ports in router i
L_{cdn}^{sd}	CDN traffic demand between node pair (s,d)
$LCDN_{ij}^{sd}$	The CDN traffic flow between node pair (s,d) traversing virtual link (i,j)
CDN_{iks}	Traffic demand between peer i in swarm k and datacenter s

We calculate the network power consumption (NPC) as discussed in [19]. The CDN datacenters power consumption (CPC) is deduced by considering the energy per bit of a typical server:

$$CPC = Epb \cdot \sum_{s \in DC} \sum_{d \in N} L_{cdn}^{sd} \quad (13)$$

Note that we only consider traffic proportional energy consumption in datacenters and do not account for the power required for redundancy, cooling or underutilization, which are useful extensions to our models. Therefore, the total power consumption (TPC) is:

$$TPC = NPC + CPC \quad (14)$$

The model is defined as follows:

Objective: Minimize

$$\begin{aligned} & \gamma \cdot \left(\sum_{i \in N} Prp \cdot Q_i + Prp \cdot \sum_{i \in N} \sum_{j \in N: i \neq j} C_{ij} + \right. \\ & \quad \left. \sum_{m \in N} \sum_{n \in Nm_m} Pt \cdot W_{mn} + \sum_{m \in N} \sum_{n \in Nm_m} Pe \cdot A_{mn} \cdot F_{mn} + \right. \\ & \quad \left. \sum_{i \in N} PO_i + \sum_{m \in N} \sum_{n \in Nm_m} Pmd \cdot F_{mn} \right) + \\ & \quad \epsilon \cdot \left(Epb \cdot \sum_{s \in DC} \sum_{d \in N} L_{cdn}^{sd} \right) \end{aligned} \quad (15)$$

Subject to:

In addition to the constraints defined in [19], the model is subject to:

$$\begin{aligned} L_{cdn}^{sd} &= \sum_{k \in Sw} \sum_{i \in Pn_{dk}: i \in L_k} \delta_s \cdot CDN_{iks} \\ &\forall s, d \in N \end{aligned} \quad (16)$$

$$\begin{aligned} \sum_{j \in N: i \neq j} LCDN_{ij}^{sd} - \sum_{j \in N: i \neq j} LCDN_{ji}^{sd} &= \begin{cases} L_{cdn}^{sd} & \text{if } i = s \\ -L_{cdn}^{sd} & \text{if } i = d \\ 0 & \text{otherwise} \end{cases} \\ &\forall s, d, i \in N: s \neq d \end{aligned} \quad (17)$$

$$\begin{aligned} \sum_{s \in N} \sum_{d \in N: s \neq d} \left(LCDN_{ij}^{sd} + L_{ij}^{sd} + \sum_{k \in Sw} L_{ijk}^{sd} \right) &\leq C_{ij} \cdot B \\ &\forall i, j \in N: i \neq j \end{aligned} \quad (18)$$

$$\begin{aligned} Avdr_{ik} &= \sum_{j \in P_k: i \neq j} SLR \cdot U_{jik} + \sum_{s \in DC} CDN_{iks} \\ &\forall k \in Sw \quad \forall i \in L_k \end{aligned} \quad (19)$$

$$\begin{aligned} Avdr_{ik} &= VSR \\ &\forall k \in Sw \quad \forall i \in L_k \end{aligned} \quad (20)$$

Equation (15) gives the model objective, i.e. to minimise the total power consumption composed of network and CDN components that are weighted by γ and ϵ , respectively while satisfying the streaming rate constraint for the VoD service. To achieve this objective the model optimises the P2P selection, given by variable U_{ijk} , as well as the CDN to peers traffic, given by CDN_{iks} .

Constraint (16) calculates the transient traffic between IP/WDM nodes due to CDN to peers traffic based on CDN_{iks} . Constraint (17) is the flow conservation constraint for the CDN to peers traffic. Constraint (18) ensures that the traffic traversing a virtual link does not exceed its capacity. Constraint (19) calculates the download rate for each peer according to the upload rate it receives from other peers selecting it and/or the traffic received from the CDN. Constraint (20) limits the download rate of a leecher to the required streaming rate for the video.

B. The CDN-P2P MILP Model Results

In the following results, we evaluate four optimisation scenarios to show the trade-off between the different content distribution approaches:

- H-MinNPC Model: A hybrid model that only minimises the IP/WDM network power consumption, i.e. ($\epsilon = 0$).
- H-MinTPC Model: A hybrid that minimizes the total power consumption (network and datacenters), i.e. ($\gamma = \epsilon = 1$)
- Only-CDN model: Peers download only from the CDN datacenters, i.e. $\sum_{j \in P_k: i \neq j} SLR \cdot U_{jik} = 0$.
- Only-P2P model: Peers download only from each other using a BitTorrent like protocol, i.e. $\sum_{s \in DC} CDN_{iks} = 0$.

We evaluate the power consumption of the different scenarios versus an increasing number of seeders in the swarms while the total number of peers is fixed, i.e. versus an increasing download capacity of the P2P system. For CDN, leechers are considered as normal clients that download from CDN directly without P2P connections. Nodes with CDN are the same set of nodes used in [19].

TABLE III
INPUT DATA FOR THE CDN-P2P MODEL

Energy per bit for VoD server (E_{pb})	437.5 W/Gbps [48]
Video streaming rate (VSR)	0.003 Gbps
Network Power consumption weight (γ)	1
CDN Power Consumption weight (ϵ)	0 or 1

Note that E_{pb} is calculated based on [48] where the server power consumption is 350 W and the capacity is 800 Mbps (0.8 Gbps), therefore, $350 \text{ W}/0.8 \text{ Gbps}=437.5 \text{ W/Gbps}$.

Fig. 12(a) shows the total power consumption (TPC), which is composed of the network power consumption (NPC) and the CDN datacenters power consumption (CPC), for the different

optimization scenarios.

From Fig. 12(a) it can be seen that the ‘Only-P2P’ model is not capable of satisfying the required video streaming rate (3Mbps) with a number of seeders lower than 65. For both hybrid models, the results show that the total power consumption is reduced as the number of seeders increases i.e. the download capacity of the P2P network increases. This is because having more seeders in the swarm, increases the likelihood that leechers will be served locally and therefore decreases the IP/WDM cross traffic as well as the load on CDN datacenters.

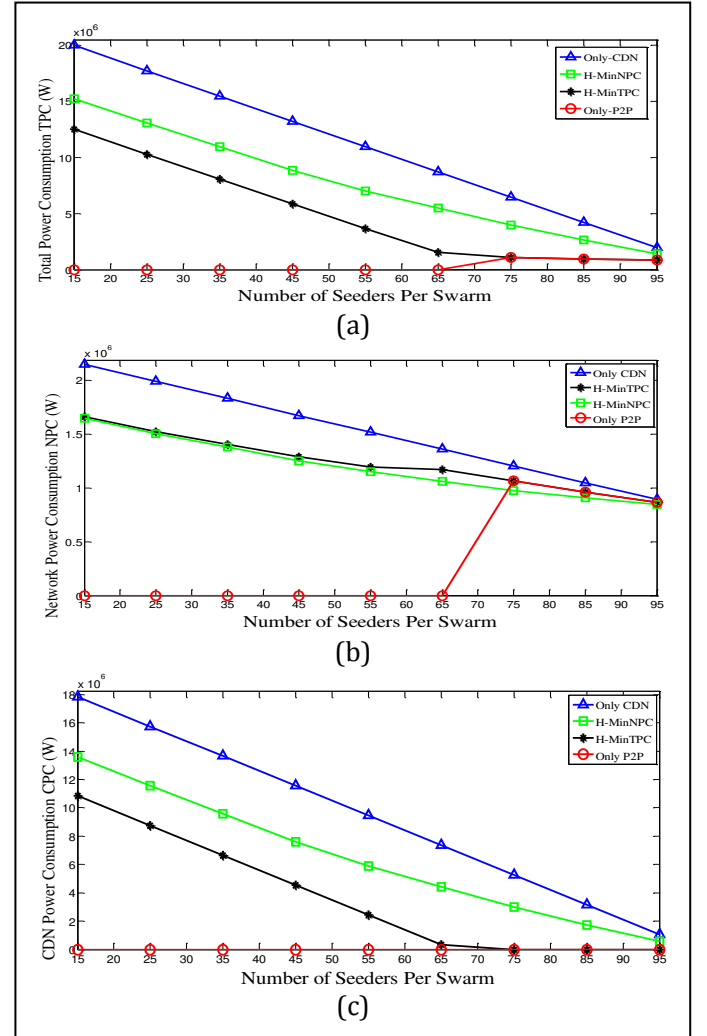

Fig. 12 CDN-P2P Results (a) Total Power Consumption (b) IP/WDM Network Power Consumption (c) CDN Datacenter Power Consumption

The H-MinTPC model is the most energy efficient solution. It consumes 44% and 61% less power compared to the H-MinNPC and Only-CDN models, respectively. This is achieved by utilising the P2P throughput as much as possible by allowing peers to upload at their maximum upload capacity while the CDN is only contacted when the P2P capacity is not enough to satisfy the required streaming rate. Similar approach is reported in [47] for

the minimized server bandwidth (MSB) heuristic as peers are looked up before CDN datacenters which means that datacenters servers are only contacted when peers are not available or have all served their share of requests. However a key distinction between our MILP model and the MSB heuristic of [47] is that we consider a BitTorrent network and not a simple P2P network. In BitTorrent a peer that is selected has to be rewarded later according to the TFT mechanism. This means that our power minimized BitTorrent network MILP may not allow peers to select very remote peers even if such peers are available due to the “double” journey imposed by TFT, and may therefore select a distant CDN location which does not add a second “reward” journey. It should be noted that BitTorrent is the most popular P2P implementation as it overcomes a number of key P2P networks problems and provides key advantages. For example if the single source in [47] (and some other P2P implementations) was to leave the network, communication fails, whereas BitTorrent eliminates this single point of failure by allowing peers to connect to multiple peers simultaneously as in our MILP and implementation. BitTorrent provides fairness through TFT, scalability and robustness by dividing the file into pieces that are downloaded. These features have their implications on power consumption and our models include these features.

Note that for a number of seeders equal to or higher than 65, the total power consumption for the H-MinTPC is equal to the P2P total power consumption as no load will be exerted on CDN datacenters. On the other hand, the H-MinNPC model saves only about 32% compared to Only-CDN model as it does not consider minimising the power consumption of datacenters.

Fig. 12(b) and Fig. 12(c) decompose the total power consumption shown in Fig. 12(a) into its two components: the network power consumption (NPC) and the CDN datacenters power consumption (CPC), respectively. As expected, the Only-CDN model is the least energy efficient at the network side. At higher number of seeders (more than 65); the network power consumption of the Only-CDN model is even higher than the total power consumption of the H-MinTPC model. The network power consumption for the H-MinNPC is slightly lower than the H-MinTPC network power consumption. This is because with MinNPC, peers prefer to stream a video from datacenters if it is not available locally rather than streaming it from other peers as traffic from datacenters does not need to be rewarded back with an equal and opposite traffic as in the case of streaming from other peers (TFT). However, high load will be exerted on datacenters resulting in higher CDN power consumption for the MinNPC model compared to the H-MinTPC model as shown in Fig. 12(c). Similar conclusion is reported in [47] for the closest source assignment (CSA) heuristic but due to different reasons, i.e. not due to TFT. In [47] the CDN servers bandwidth might increase as requests are served from the closest content source available whether it is a peer or a CDN datacenter and peers are not deliberately looked up before CDN datacenter.

Nevertheless, H-MinNPC is easier to implement in practice as it does not require peers to be aware of other peers in neighbouring

IP/WDM nodes and it shows that it is still possible to achieve total power saving compared to Only-CDN model by having peers with lower upload utilization.

It can be observed in Fig. 12 that for the hybrid and the Only-CDN models, the major contribution to the total power consumption comes from the CDN datacenters because of the inefficient servers used to distribute the VoD service compared to the energy efficient IP/WDM network.

To overcome the inefficiency of the Only-CDN model, servers with higher energy efficiency are needed. To find out the energy per bit of CDN servers required so that the Only-CDN model is as energy efficient as the MinTPC model, we equate the total power consumption of the Only-CDN model to that of the H-MinTPC model:

$$(Epb_{future}/Epb_o) \cdot CPC_{OnlyCDN} + CNP_{OnlyCDN} = TPC_{HMinTPC} \quad (21)$$

where Epb_o and Epb_{future} are the current and future energy per bit for servers, respectively and $CPC_{OnlyCDN}$ and $CNP_{OnlyCDN}$ are the Only-CDN datacenters and network power consumption, respectively. $TPC_{HMinTPC}$ is the total power consumption of the H-MinTPC model.

Hence:

$$Epb_{future} = Epb_o \cdot \frac{TPC_{HMinTPC} - CNP_{OnlyCDN}}{CPC_{OnlyCDN}} \quad (22)$$

Note that Epb_{future} is different for different number of seeders per swarm. While for 15 seeders per swarm, Epb_{future} is equal to 254W/Gbps; Epb_{future} is 9.5W/Gbps for 65 seeders. However, the servers manufacturing technology still does not support such energy efficiency. Therefore, hybrid CDN-P2P is very efficient at postponing upgrading datacenters in terms of capacity and power consumption.

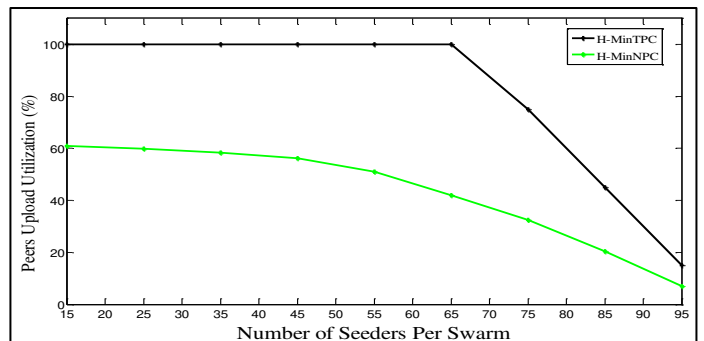

Fig. 13 File Sharing Effectiveness

Fig. 13 shows the average file sharing effectiveness for the hybrid models calculated as:

$$\eta = \sum_{k \in Sw} \sum_{i \in L} \sum_{j \in L: i \neq j} U_{ijk} / (SLN \cdot LN \cdot SN) \quad (23)$$

File sharing effectiveness (η , where $0 \leq \eta \leq 1$), is found theoretically to be almost 1 [13] which can be understood as a consequence of the optimality of BitTorrent LRF as discussed

in section III.A. However for video streaming, BitTorrent needs to be modified to satisfy the streaming requirements, which might lead to decreasing η as not all pieces can be downloaded in arbitrary fashion due to streaming constrains. The H-MinTPC model in Fig. 13 maintains full file sharing effectiveness by allowing peers to contact other peers in neighbouring nodes when the local capacity is not enough until peers have sufficient capacity (at $DN \geq 65$) where lower upload capacity will be enough to satisfy the streaming demand. Conversely, as discussed above the H-MinNPC model limits the majority of peers to their local nodes leading to lower file sharing effectiveness. The H-MinNPC architecture should maintain an average file sharing effectiveness of $\eta = 0.43$ (obtained by averaging peers upload utilization over the different number of seeders per swarm in Fig. 13) as with a reduced file sharing effectiveness, which is usually associated with less popular files, the throughput of the P2P system might be insignificant and users might experience poor QoS and therefore, the H-MinNPC model loses its advantage over to the Only-CDN scenario.

Fig. 14 (left hand side) shows the power consumption of individual datacenters at different number of seeders for the H-MinTPC model under the bypass approach. Datacenters have dissimilar power consumption levels at a particular number of seeders per swarm because of the unbalanced load on these datacenters. CDN providers prefer to balance the load on their datacenters to increase the likelihood of serving more nearby users. To evaluate the impact of balancing the datacenters loads in the hybrid CDN-P2P architecture, we add a constraint to our model to ensure that all datacenters receive the same traffic load:

$$\sum_{d \in N} L_{cdn}^{sd} = \frac{1}{DCN} \cdot \sum_{i \in DC} \sum_{j \in N} L_{cdn}^{ij} \quad \forall s \in DC \quad (24)$$

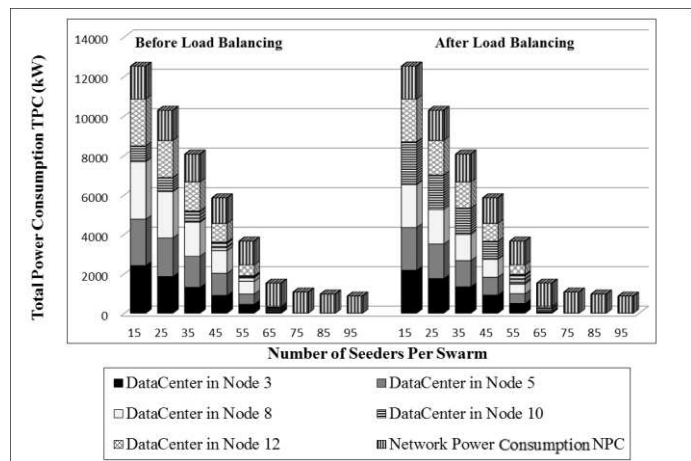

Fig. 14 Total Power Consumption (IP/WDM and Data Centers) With and Without Load Balancing in CDN-P2P

Note that in practice, it might not be possible to reach such sharp balance, however we consider it in our model for illustration purposes. Fig. 14 (right hand side) shows that balancing

the load of datacenters has no significant impact on the network power consumption, i.e. the power savings and performance of the hybrid CDN-P2P architecture are not scarified if load balancing is implemented.

Finally, key distinctions between the operator controlled seeders of Section V and the CDN-P2P in Section VI include the fact that operator controlled seeders increase their rate just to compensate for the number of peers who have left, while the CDN in CDN-P2P may offer more rate if demanded. The maximum number of available sources to download from in operator controlled seeders remains constant and is equal to the swarm size and compensation is achieved by the operator increasing the rate offered by its controlled seeders. In the CDN-P2P network, the CDN sources are in addition to the swarm size.

In the next section we report the experimental demonstration of our concepts.

VII. ENERGY EFFICIENT BITTORRENT EXPERIMENTAL DEMONSTRATION

We further evaluated the EEBT heuristic proposed in [19] by building an experimental demonstration to demonstrate its performance and energy consumption over the NSFNET network topology. In the following subsections we discuss the experimental setup and introduce and analyse the results of the experiment.

A. Experimental Setup:

Each node in the NSFNET topology is emulated using a Cisco 10GE, SG 300-10, Layer 3 switch router. Each router is connected to an HP ProLiant DL120G7 server where several instances of the BitTorrent protocol are implemented to represent several peers located at the node. This setup is cost efficient and allows us to distribute peers over the network nodes as required. Table IV summarises the details of the hardware we used in our experiment. Fig. 15 shows the routers and switches placed in two racks and connected to each other to form the NSFNET topology.

TABLE IV: DEMO HARDWARE COMPONENTS

Hardware	Number	Type	Specifications
Router	14	Cisco SG 300-10	10 GE ports [49]
Server	14	HP ProLiant DL120G7	Intel® Xeon® E3, RAM 4GB, HD250GB [50]

We implemented the BitTorrent protocol in Python 2.7 using the asynchronous event driven TWISTED library which is the same library the first open source BitTorrent was written in. Our BitTorrent implementation captures the protocol algorithms that control the behaviour of peers such as the choke algorithm (for leechers and seeders), optimistic unchoke, TFT and LRF. We considered the specifications in [51] - [52] as they represent the most popular detailed explanation of BitTorrent online. Also we

implemented a tracker protocol and integrated it with statistics collection tool to analyse the results of the experiment. Finally we integrated the MATLAB plotting library, Matplotlib [53], with the tracker to display the result instantly.

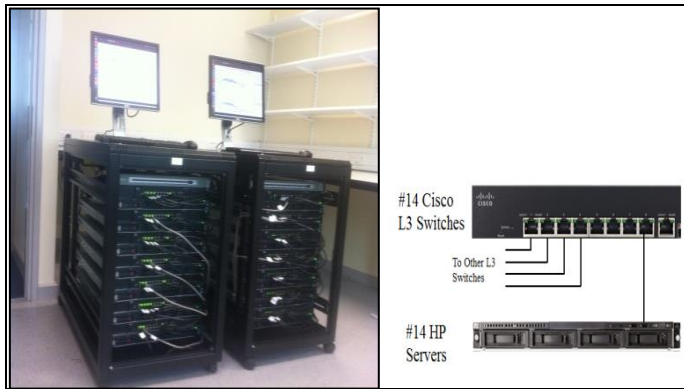

Fig. 15 Experiment Racks and Connectivity

The results obtained from the experiment are updated every 1 second on the monitor screen. The network power consumption is calculated based on the traffic demands between network node pairs which can be calculated given the peers' locations and their download rate obtained from the experiment. Given this experimental demand distribution, we use the same power consumption values used in the previous modelling sections (Table II) to estimate the power consumption of the experimental setup.

We run the experiment considering a swarm of 56 peers sharing a 40MB file which is divided into pieces of 256kB. Each node has 4 peers, each with an upload capacity of 1Mbps, and one of them is a seeder.

B. Experimental Results:

The power consumption calculated in the experiment is attributed to the IP layer and optical layer considering the non-bypass approach. Fig. 16 and Fig. 17 show the experimental results for the OBT and EEBT, respectively. They also show the results of the model in [19] considering the peers distribution of the experiment.

Both OBT and EEBT achieve a comparable average download rate of about 1Mbps. At steady state (between 100 and 200 seconds) where all leechers are downloading and uploading at full capacity, the average download rate reaches 1.3 Mbps which is consistent with the theoretical average download rate [37]. This reflects the efficiency of the LRF algorithm in distributing pieces among leechers during steady state. While OBT consumes 400kW on average, the energy efficient version consumes 240kW, saving about 40% of power. The power consumption values are averaged over the interval from 50-300 seconds.

As all peers have to download a 40MB (320Mb) file and with average download rate of 1Mbps, we expect theoretically that all peers have to finish download at 320 seconds. However, the experimental results in Fig. 16 and Fig. 17 show a longer average download time of about 400 seconds for both versions of BitTorrent. This is because not all leechers finish exactly at 320

seconds as some uploaders may favour some leechers over others at different times so these leechers receive more than the average download rate of 1Mbps and other leechers receive less than 1Mbps and hence their finishing time is delayed beyond the average download time of 320 seconds.

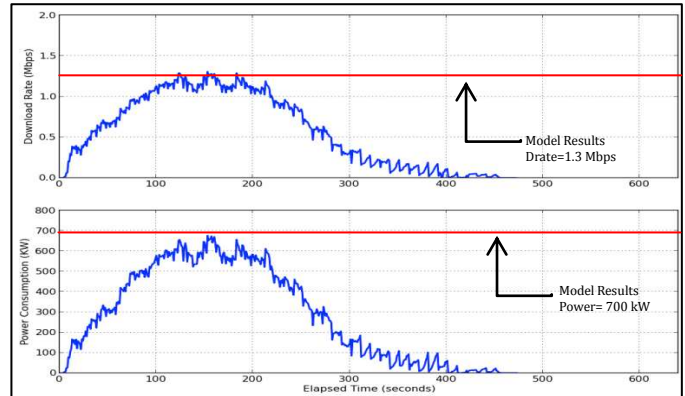

Fig. 16 Experimental Average Download Rate and IP/WDM Power Consumption of Original BitTorrent (OBT)

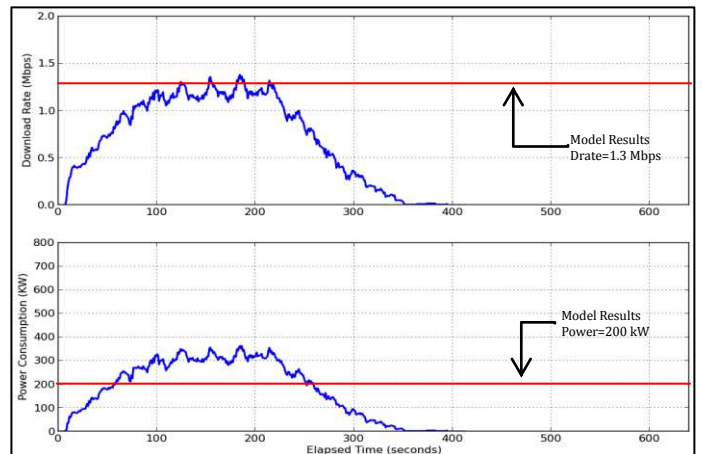

Fig. 17 Experimental Average Download Rate and IP/WDM Power Consumption of Energy Efficient BitTorrent (EEBT)

At steady state, the OBT model and the experiment are in good agreement and have almost similar power consumption as shown in Fig. 16. The power consumption of the EEBT model is however 33% lower (Calculated by taking the steady state average power consumption of the EEBT experiment, 300 kW, as the model only works for steady state case) compared to experiment as shown in Fig. 17. This is due to two reasons: Firstly, the model assumes optimal LRF which means that all needed pieces can be found in the local node and therefore neighbouring nodes are only contacted when the average download rate falls below the optimal 1.3 Mbps. In contrast, the experimental test-bed has less optimal LRF, as some needed pieces might not be available in the local nodes. Secondly, as mentioned in Table I the average nodal degree in NSFNET is about 2 which make it more likely to download pieces from a neighbouring node than from the same node as peers in the energy efficient implementation uniformly scan local and neighbouring nodes for peers selections.

Fig. 18 shows the number of hops travelled by the file pieces to get to the leechers requesting them for the OBT and EEBT experiments. The OBT experimental results (Fig. 18(a)) resulted in 5% and 28% of pieces being downloaded from local nodes ($H=0$) and neighbouring nodes ($H=1$), respectively. On the other hand, with the EEBT (Fig. 18(b)) 30% of the pieces are served from local nodes and 70% of pieces are downloaded from sources located in neighbouring nodes ($H=1$). This is due to uniform neighbourhood scanning as discussed above.

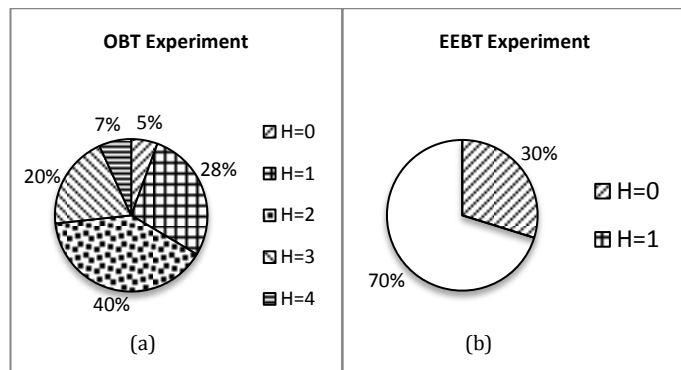

Fig. 18 Locality for Experimental OBT and EEBT

VIII. CONCLUSIONS

This paper has introduced an extended study of the performance and energy efficiency of the BitTorrent protocol in IP/WDM networks. Different aspects of the energy efficiency of BitTorrent have been investigated including the impact of network topology, enhancing the performance of EEBT heuristic, introducing operator controlled seeders, studying CDN-P2P architecture, and building an experimental demonstrator to validate the model and heuristic results. The results show that the EEBT is able to achieve higher energy savings on networks with fewer nodes for a given swarm size as the probability of finding sufficient peers locally to connect with increases. For two networks with the same number of nodes, the energy efficiency is a function of the average hop count as the number of network devices in the optical layer increases with the hop count. The results of an enhanced EEBT heuristic show that to match the performance of the OBT protocol, peers have to cross more hops if the number of peers in the local node is not sufficient, decreasing the energy saving to 11% compared to 17% when peers are limited to one hop across the network. We have also shown that to mitigate the impact of leechers leaving the network after finishing downloading, optimising the location as well as the upload rate of operator controlled seeders maintains the download rate and moreover saves 15% energy compared to the case where leechers stay after finishing the downloading process. We also investigated the power consumption of VoD services using CDN, P2P and the promising hybrid CDN-P2P architecture over bypass IP/WDM networks. We developed a MILP model to analyse the performance of the hybrid CDN-P2P architecture. Our results indicate that location aware hybrid CDN-P2P is a promising architecture not in terms of cost and performance only but also in terms of energy consumption. We have investigated

two scenarios for the hybrid CDN-P2P architecture: the H-MinNPC model where the model minimizes the IP/WDM network power consumption and the H-MinTPC model where the model minimizes the total power consumption including the network and the CDN datacenters power consumption. While the H-MinTPC has saved 61% of the total power consumption compared to CDN-Only architecture, the savings achieved by the H-MinNPC is limited to 32%. The energy efficiency introduced by the hybrid CDN-P2P architecture can effectively defer the upgrade of CDN datacenters in terms of capacity and energy efficiency. The results also show that to maintain the power savings achieved by the H-MinNPC model, the P2P system should maintain an average file sharing effectiveness of $\eta=0.43$. Furthermore, we show that the attempts of content providers to balance the load among their datacenters will not affect the overall energy savings and performance of the hybrid architecture. Finally we conducted an experimental evaluation of OBT and EEBT. The results show about 40% saving in power consumption for the EEBT while the average download rate is maintained at 1Mbps.

ACKNOWLEDGMENTS

The authors would like to acknowledge funding from the Engineering and Physical Sciences Research Council (EPSRC), INTERNET (EP/H040536/1) and STAR (EP/K016873/1. The first author would like to acknowledge his PhD scholarship awarded by the Iraqi Ministry of Higher Education and Scientific Research.

REFERENCES

- [1] P. Gill, M. Arlitt, Z. Li and A. Mahanti "The flattening Internet topology: Natural evolution, unsightly barnacles or contrived collapse?", Proc. PAM, pp.1-10 2008
- [2] "U.S. Environmental Protection Agency's Report to Congress on Server and Data Center Energy Efficiency," August 2, 2007. Available: http://hightech.lbl.gov/documents/data_centers/epa-datacenters.pdf. Last Access Date: 9 Dec 2013
- [3] A. Beloglazov, R. Buyya, Y. C. Lee, A. Zomaya, "A Taxonomy and Survey of Energy-Efficient Data Centers and Cloud Computing Systems", Advances in Computers, vol. 82, pp. 47-111, Mar. 2011.
- [4] X. Dong, T. El-Gorashi, and J. M. H. Elmirghani, "Green IP over WDM networks with data centers," IEEE/OSA J. of Lightwave Technology, vol. 29, no. 12, pp. 1861-1880, 2011
- [5] J. Baliga, R. Ayre, K. Hinton, and R. Tucker, "Green Cloud Computing: Balancing Energy in Processing, Storage, and Transport," Proc. of the IEEE, vol. 99, no. 1, pp. 149-167, 2011.
- [6] E. K. Lua, J. Crowcroft, M. Pias, R. Sharma, and S. Lim, "A survey and comparison of peer-to-peer overlay network schemes," IEEE Commun. Surveys Tutorials, vol. 7, no. 2, pp. 72-93, Quarter 2005.

- [7] Envisional Ltd, "Technical report: An Estimate of Infringing Use of the Internet.", January 2011. Available: http://documents.envisional.com/docs/Envisional-Internet_Usage-Jan2011.pdf. Last Access Date: 9 Dec 2013
- [8] Sandvine Corporate, "Global Internet Phenomena Report.", 2011. Available: http://www.wired.com/images_blogs/epicenter/2011/05/SandvineGlobalInternetSpringReport2011.pdf. Last Access Date: 9 Dec 2013
- [9] B. Cohen, "Incentives build robustness in BitTorrent" In Workshop on Economics of Peer-to-Peer systems, vol. 6, pp. 68-72. 2003
- [10] R. Bindal, P. Cao, and W. Chan, "Improving traffic locality in BitTorrent via biased neighbor selection," 26th IEEE Int. Conf. Distrib. Comput. Syst. ICDCS06, vol. 06, pp. 66-66, 2006.
- [11] G. Anastasi, I. Giannetti, A. Passarella, "A BitTorrent Proxy for Green Internet File Sharing: Design and Experimental Evaluation", Computer Communications, vol. 33, n. 7, pp. 794-802, May 2010.
- [12] H. Hlavacs, R. Weidlich, and T. Treutner, "Energy efficient peer-to-peer file sharing", The Journal of Supercomputing, vol. 62, no. 3, pp. 1167-1188, Apr. 2011.
- [13] D. Qiu and R. Srikant, "Modeling and performance analysis of BitTorrent-like peer-to-peer networks," in ACM SIGCOMM Computer Communication Review, vol. 34, no. 4, pp. 367-378, 2004
- [14] S. Nedeveschi, S. Ratnasamy, and J. Padhye, "Hot Data Centers vs. Cool Peers," in Workshop on Power Aware Computing and Systems (HotPower '08), San Diego, CA, Dec 2008.
- [15] U. Mandal, C. Lange, A. Gladisch, P. Chowdhury, and B. Mukherjee, "Energy-efficient content distribution over telecom network infrastructure," Proc. 13th International Conference on Transparent Optical Networks (ICTON), pp. 1-4, June 2011.
- [16] A. Feldmann, M. Kind, A. Gladisch, G. Smaragdakis, C. Lange, and F. J. Westphal, "Energy trade-offs among content delivery architectures," Proc. 9th Conference of Telecommunication, Media and Internet Techno-Economics (CTTE), Ghent, Belgium, pp. 1-6, June 2010.
- [17] U. Lee, I. Rimac, and V. Hilt, "Greening the internet with content-centric networking," Proc. 1st International Conference on Energy-Efficient Computing and Networking. e-Energy 10, pp. 179-182, 2010.
- [18] W. Huang, C. Wu, and F. C. M. Lau, "The Performance and Locality Tradeoff in BitTorrent-Like P2P File-Sharing Systems," 2010 IEEE Int. Conf. Commun., pp. 1-5, May 2010
- [19] A. Lawey, T. El-Gorashi, and J. MH Elmirghani. "Energy-efficient peer selection mechanism for BitTorrent content distribution." In Global Communications Conference (GLOBECOM), pp. 1562-1567, 2012
- [20] X. Dong, A. Lawey, T. E. H. El-Gorashi, and J. M. H. Elmirghani, "Energy-efficient core networks," in 2012 16th International Conference on Optical Network Design and Modelling (ONDM), pp. 1-9, 2012
- [21] A. Lawey, T. El-Gorashi, and J. MH Elmirghani, "Impact of peers behaviour on the energy efficiency of BitTorrent over optical networks," 14th International Conference on Transparent Optical Networks (ICTON), pp. 1-8, 2012.
- [22] Ahmed Q. Lawey, Taisir E. H. El-Gorashi, Fuad E. Alsaadi, and J. MH Elmirghani, "P2P Content Distribution in Renewable Energy Powered Optical Core Networks," Submitted to IEEE/OSA J. of Optical Communications and Networking, Feb 2014.
- [23] G. Shen and R. S. Tucker, "Energy-minimized design for IP over WDM networks," IEEE/OSA J. of Optical Communications and Networking, vol. 1, pp. 176-186, 2009.
- [24] X. Dong, T. El-Gorashi, and J. M. H. Elmirghani, "IP Over WDM Networks Employing Renewable Energy Sources," IEEE/OSA J. of Lightwave Technology, vol. 29, no. 1, pp. 3-14, 2011.
- [25] X. Dong, T. El-Gorashi, J. M. H. Elmirghani, "On the Energy Efficiency of Physical Topology Design for IP over WDM Networks", IEEE/OSA J. of Lightwave Technology Vol. 30, Issue 11, pp. 1694-1705, 2012
- [26] A. Legout, G. Urvoy-Keller, and P. Michiardi, "Rarest first and choke algorithms are enough," Proc. 6th ACM SIGCOMM conference on Internet measurement, pp. 203-216, 2006
- [27] J. He, A. Chaintreau, and C. Diot, "A performance evaluation of scalable live video streaming with nano data centers," Comput. Networks, vol. 53, no. 2, pp. 153-167, 2009.
- [28] R. Kumar, Y. Liu, and K. Ross, "Stochastic fluid theory for P2P streaming systems," IEEE INFOCOM, pp. 919-927, 2007.
- [29] GreenTouch, "Core Switching and Routing Working Group Overview, Research Targets and Challenges," GreenTouch Open Forum, 17 Nov 2011. Available <http://www.greentouch.org/uploads/documents/GreenTouch%20CS&R%20Working%20Group%20Presentation%20-%20Seattle%202011%20-%20v10.pdf>. Last Access Date 11 Nov 2013.
- [30] Cisco Systems, "Cisco CRS-1 8-Slot Single-Shelf System," available: http://www.cisco.com/en/US/prod/collateral/routers/ps5763/ps6112/product_data_sheet0900aecd801d53a1.pdf.
- [31] Glimmerglass, "Data sheet of Glimmerglass Intelligent

- Optical System 500,," available: <http://www.glimmerglass.com/products/intelligent-optical-systems/>.
- [32] Cisco Systems, "Cisco ONS15501 Erbium Doped Fiber Amplifier Data Sheet," available: http://www.cisco.com/en/US/products/hw/optical/ps2011/products_data_sheet09186a008008870d.html.
- [33] Cisco Systems, "Data sheet of Cisco ONS 15454 100-GHz 4-CH Multi/ Demultiplexer," available: http://www.cisco.com/en/US/prod/collateral/optical/ps5724/ps2006/product_data_sheet09186a00801a5572_ps5791_Products_Data_Sheet.html.
- [34] S. Knight, H. X. Nguyen, N. Falkner, R. Bowden, and M. Roughan, "The Internet Topology Zoo," *Sel. Areas Commun. IEEE J.*, vol. 29, no. 9, pp. 1765–1775, 2011.
- [35] Topology Zoo, "ATT North America," Available <http://topology-zoo.org/maps/AttMpls.jpg>. Last access date 14 Dec 2013.
- [36] D-maps, "United States of America (USA) / United States of America," Available http://d-maps.com/carte.php?num_car=11857&lang=en. Last access date 14 Dec 2013
- [37] K. Eger, T. Hoßfeld, A. Binzenh, and G. Kunzmann, "Efficient Simulation of Large-Scale P2P Networks: Packet-level vs. Flow-level Simulations," *Methodology*, pp. 9–15, 2007. *Proc. 2nd workshop on Use of P2P, GRID and agents for the development of content networks (ACM)*, pp. 9-16., 2007
- [38] Topology Zoo, "BT Europe," Available <http://topology-zoo.org/maps/BtEurope.jpg>. Last access date 14 Dec 2013.
- [39] d-maps, "Europe," Available http://d-maps.com/carte.php?num_car=30073&lang=en. Last access date 14 Dec 2013
- [40] T. E. H. El-Gorashi, A. Mujtaba, W. Adlan, and J. M. H. Elmirghani, "Storage area networks extension scenarios in a wide area WDM mesh architecture under heterogeneous traffic," *Proc. 11th Int. Conf. Transparent Opt. Networks*, pp. 1–8, 2009.
- [41] d-maps, "Italy / Repubblica Italiana," Available http://d-maps.com/carte.php?num_car=18137&lang=en. Last access date 14 Dec 2013
- [42] D. Xu, S. Kulkarni, C. Rosenberg, and H. K. Chai, "A CDN-P2P hybrid architecture for cost-effective streaming media distribution," *Comput. Networks*, vol. 44, no. 3, pp. 353–382, 2004.
- [43] S. Kang and H. Yin, "A Hybrid CDN-P2P System for Video-on- Demand", *Proc. IEEE International Conference on Future Networks*, pp. 309-313, 2010.
- [44] Z. Lu, J. Wu, and W. Fu, "Towards a Novel Web Services Standard-Supported CDN-P2P Loosely-Coupled Hybrid and Management Model," *IEEE International Conference on Services Computing (SCC)*, pp. 297-304, 2010
- [45] P. Shi, H. Wang, Y. Gang, and X. Yuan, "ACON: Adaptive construction of the overlay network in CDN-P2P VoD system," *IEEE 3rd International Conference on Communication Software and Networks (ICCSN)*, pp. 182–187, 2011
- [46] C. A. Chan, E. Wong, A. Nirmalathas, and C. Jayasundara, "Energy Efficient Delivery Methods for Video-rich Services over Next Generation Broadband Access Networks," *IEEE International Conference on Communications (ICC)*, pp. 1-5, 2011.
- [47] U. Mandal, C. Lange, A. Gladisch, and B. Mukherjee, "Should ISPs adopt hybrid CDN-P2P in IP-over-WDM networks: An energy-efficiency perspective?," *IEEE International Conference on Advanced Networks and Telecommunications Systems (ANTS)*, pp. 6–11, 2012
- [48] J. Baliga, R. Ayre, K. Hinton, and R. S. Tucker, "Architectures for energy-efficient IPTV networks," in *Optical Fiber Communication Conference*, 2009, p. OThQ5.
- [49] Cisco Systems, "Data sheet of Cisco 300 Series Switches." Available: http://www.cisco.com/en/US/prod/collateral/switches/ps5718/ps10898/data_sheet_c78-610061.html. Last Access Date 9 Dec 2013.
- [50] HP, "Data sheet of HP ProLiant DL120 G7 Server series." Available: http://www.hp.com/hpinfo/newsroom/press_kits/2011/poweryourdream/HP_ProLiant_DL120_G7_Datasheet.pdf. Last Access Date 9 Dec 2013.
- [51] B. Cohen, "The BitTorrent Protocol Specification," Available: http://www.bittorrent.org/beps/bep_0003.html. Last Access Date 9 Dec 2013.
- [52] J. Fonseca, B. Reza, and L. Fjeldsted "BitTorrent Protocol -- BTP/1.0," Available: <http://jonas.nitro.dk/bittorrent/bittorrent-rfc.html>. Last Access Date 9 Dec 2013.
- [53] "http://matplotlib.org". Last Access Date 9 Dec 2013.

Ahmed Q. Lawey received the BS degree (first-class Honours) in computer engineering from the University of Nahrain, Iraq, in 2002, the MSc degree (with distinction) in computer engineering from University of Nahrain, Iraq, in 2005. He is currently working toward the PhD degree in the School of Electronic and Electrical Engineering, University of Leeds, Leeds, UK From 2005 to 2010 he was a core network engineer in ZTE Corporation for Telecommunication, Iraq branch. His current research interests include energy optimization of IT networks, energy aware content distribution in the Internet and energy efficient routing protocols in optical networks.

Taisir E.H. El-Gorashi received the BS degree (first-class Honours) in electrical and electronic engineering from the University of Khartoum, Sudan, in 2004, the M.Sc. degree (with Distinction) in photonic and communication systems from the University of Wales, Swansea, UK, in 2005, and the PhD degree in optical networking from the University of Leeds, Leeds, UK, in 2010. She is currently a Postdoctoral Research Fellow in the School of Electronic and Electrical Engineering, University of Leeds. Her research interests include next-generation optical network architectures and green Information and Communication Technology.

Jaafar M. H. Elmirghani is the Director of the Institute of Integrated Information Systems within the School of Electronic and Electrical Engineering, University of Leeds, UK. He joined Leeds in 2007 and prior to that (2000–2007) as chair in optical communications at the University of Wales Swansea he founded, developed and directed the Institute of Advanced Telecommunications and the Technium Digital (TD), a technology incubator/spin-off hub. He has provided outstanding leadership in a number of large research projects at the IAT and TD. He received the BSc degree (first-class Honours) in electrical and electronic engineering from the University of Khartoum, Sudan, in 1989 and the Ph.D. degree in the synchronization of optical systems and optical receiver design from the University of Huddersfield UK in 1994. He has co-authored *Photonic switching Technology: Systems and Networks*, (Wiley) and has published over 400 papers. He has research interests in optical systems and networks and signal processing. Prof. Elmirghani is Fellow of the IET, Fellow of the Institute of Physics and Senior Member of IEEE. He was Chairman of IEEE Comsoc Transmission Access and Optical Systems technical committee and was Chairman of IEEE Comsoc Signal Processing and Communications Electronics technical committee, and an editor of *IEEE Communications Magazine*. He was founding Chair of the Advanced Signal Processing for Communication Symposium which started at IEEE GLOBECOM'99 and has continued since at every ICC and GLOBECOM. Prof. Elmirghani was also founding Chair of the first IEEE ICC/GLOBECOM optical symposium at GLOBECOM'00, the Future Photonic Network Technologies, Architectures and Protocols Symposium. He chaired this Symposium, which continues to date under different names. He was the founding chair of the first Green Track at ICC/GLOBECOM at GLOBECOM 2011, and is Chair of the IEEE Green ICT committee within the IEEE Technical Activities Board (TAB) Future Directions Committee (FDC), a pan IEEE Societies committee responsible for Green ICT activities across IEEE, 2012-2015. He is and has been on the technical program committee of 33 IEEE ICC/GLOBECOM conferences between 1995 and 2014 including 14 times as Symposium Chair. He received the IEEE Communications Society Hal Sobol award, the IEEE Comsoc Chapter Achievement award for excellence in chapter activities (both in 2005), the University of Wales Swansea Outstanding Research Achievement Award, 2006, the IEEE Communications Society

Signal Processing and Communication Electronics outstanding service award, 2009 and a best paper award at IEEE ICC'2013. He is currently an editor of *IET Optoelectronics*, editor of *Journal of Optical Communications*, Co-Chair of the GreenTouch Wired, Core and Access Networks Working Group, an adviser to the Commonwealth Scholarship Commission, member of the Royal Society International Joint Projects Panel and member of the Engineering and Physical Sciences Research Council (EPSRC) College. He has been awarded in excess of £22 million in grants to date from EPSRC, the EU and industry and has held prestigious fellowships funded by the Royal Society and by BT. He is an IEEE Distinguished Lecturer.