

promoting access to White Rose research papers



Universities of Leeds, Sheffield and York
<http://eprints.whiterose.ac.uk/>

This is an author produced version of a paper published in **Psychology of Sport and Exercise**

White Rose Research Online URL for this paper:

<http://eprints.whiterose.ac.uk/id/eprint/74583>

Paper:

Hill, AP, Curran, T, Hall, HK and Appleton, PR (2011) *Passion and burnout in elite junior soccer players: The mediating role of self-determined motivation*. Psychology of Sport and Exercise, 12 (6). 655 - 661 (7). ISSN 1469-0292

<http://dx.doi.org/10.1016/j.psychsport.2011.06.004>

1 Passion and burnout in elite junior soccer players: The mediating role of self-determined mo-
2 tivation

3

4

5

6

7 Curran, T. Appleton, P. R. Hill, A. P. & Hall, H. K. (2011) Passion and burnout in elite junior
8 soccer players: The mediating role of self-determined motivation. *Psychology of Sport and*
9 *Exercise, 12, 655-661.*

10

11

12

13

14

15

16

17

18

19

20

21

22

23

24

25

1 Abstract

2 *Objectives:* The purpose of the study was to examine the relationship between forms of pas-
3 sion (harmonious and obsessive) and athlete burnout, and whether these relationships are me-
4 diated by self-determined motivation. The proposed model posited that because harmonious
5 passion originates from an authentic self, it will be positively associated with self-determined
6 regulation. Conversely, because obsessive passion originates from ego-invested structures
7 within the self, it will be negatively associated with self-determined regulation. In turn, con-
8 sistent with research examining the relationship between motivation regulation and athlete
9 burnout, self-determined regulation was expected to be negatively associated with athlete
10 burnout.

11 *Design:* Cross-sectional survey.

12 *Method:* This model was tested in 149 (M age = 16.2, s = 2.0, range = 12-21) male junior ath-
13 letes who attended soccer academies in the UK. Participants completed the Passion Scale
14 (Vallerand et al, 2003), the Sport Motivation Scale (Pelletier et al, 1995), and the Athlete
15 Burnout Questionnaire (Raedeke & Smith, 2001).

16 *Results:* Harmonious passion was negatively related to a latent athlete burnout variable,
17 whereas obsessive passion was unrelated to a latent athlete burnout variable. Path analysis
18 indicated that the relationship between harmonious passion and burnout was fully mediated
19 by self-determined regulation.

20 *Conclusions:* The results suggest that harmonious passion may offer some protection from
21 burnout for athletes due to higher levels of self-determined motivation.

22

23

24

25

1 Cresswell, 2007; Lemyre, Treasure & Roberts, 2006). One important feature of athlete moti-
2 vation that may provide insight into the development of athlete burnout, is the form of pas-
3 sion that energises participation (Carbonneau, Vallerand, Fernet, & Guay, 2008; Vallerand,
4 Paquet, Philippe & Charest, 2010).

5 *Passion as an antecedent to athlete burnout*

6 Passion is defined as a strong inclination toward an activity that one enjoys, finds im-
7 portant and in which individuals invest time and energy (Vallerand et al., 2003). Although
8 passion ensures willing participation, it has the potential to underpin both positive and nega-
9 tive outcomes depending on the type of passion exhibited. Vallerand et al (2003) propose that
10 individuals internalize activities in two ways and that this internalisation determines the type
11 of passion that develops. Solely autonomous internalisation of an activity is thought to result
12 in harmonious passion. In contrast, partial or controlled internalisation leads to the develop-
13 ment of obsessive passion (Vallerand, 2008). While harmonious passion leads to positive
14 outcomes such as eagerness, flow and post-participation replenishment (Hodgins & Knee,
15 2002), obsessive passion is thought to lead to ego-investment, heightened self-awareness, and
16 rigid task engagement (see Vallerand, 2008). Differences between these forms of passion
17 have also emerged in terms of their relationship with burnout. Specifically, obsessive passion
18 has been found to be positively related to burnout, whereas harmonious passion was negative-
19 ly related to the syndrome in occupational settings (Carbonneau et al., 2008; Vallerand et
20 al., 2010).

21 Research has yet to examine the relationship between passion and athlete burnout.
22 However, research in sport has supported the contention that harmonious and obsessive pas-
23 sions are likely to have distinct motivational consequences (Vallerand et al., 2003; Vallerand
24 et al., 2006; Vallerand et al., 2008). It is especially noteworthy that obsessive passion is asso-
25 ciated with a number of psychological costs that are unrelated to harmonious passion. Obses-

1 sive passion, for example, has been found to be positively related to rigid persistence (Valle-
2 rand et al., 2003), life conflict (Seguin-Levesque, Lalibere, Pelletier, Blanchard & Vallerand,
3 2003), rumination in the absence of the activity (Ratelle, Vallerand, Mageau, Rousseau &
4 Provencher, 2004), chronic injury (Rip, Fortin & Vallerand, 2006), negative affect (Vallerand
5 et al., 2003) and avoidance goals (Vallerand et al., 2008). In contrast, harmonious passion is
6 inversely related to negative affect and cognition and positively related to life satisfaction,
7 positive affect and vitality (see Vallerand, 2008). Based on these findings, one might expect
8 types of passion to predict athlete burnout in similar manner as has been observed outside of
9 sport.

10 *The mediating role of self-determined motivation*

11 According to Eklund & Cresswell (2007), burnout can be characterised by a distinct
12 pattern of motivational regulation described within self-determination theory (Deci & Ryan,
13 1985). Self-determination theory conceptualises motivational regulation along a continuum
14 from self-determined (intrinsic) to non-self-determined (extrinsic) to amotivation (Vallerand,
15 1997). This continuum is often represented by a self-determination index that considers the
16 relative contribution of the discrete motivational regulations within the theory (e.g. Gillet,
17 Vallerand, Amoura & Baldes, 2010; Lonsdale, Hodge & Rose, 2009; Taylor, Ntoumanis &
18 Standage, 2008). For instance, intrinsic motivation is behavioural regulation that is fully self-
19 determined. Extrinsic motivation, on the other hand, consists of several forms of behavioural
20 regulation, which differ in degree of self-determination. Integrated and identified regulations
21 are autonomous forms of extrinsic motivation because, though engagement is for external
22 reasons, behaviour is regulated out of choice. Introjected and external regulations are con-
23 trolled forms of extrinsic motivation because behaviour is fuelled by pressures that emanate
24 from internal (i.e. ego enhancement) or external (i.e. rewards) contingencies. The final moti-
25 vation on the self-determination continuum is amotivation, which is an absence of motiva-

1 tional quantity. Within this framework, the defining motivational features of athlete burnout
2 are thought to be lower levels of intrinsic motivation and higher levels of controlled and amo-
3 tivation (Eklund & Cresswell, 2007). In accord, research has found that higher athlete burn-
4 out is associated with less self-determined regulation and lower scores on the self-
5 determination index (Lonsdale et al., 2009; Lemyre et al., 2006).

6 The contextual motivational processes that are central to understanding athlete burn-
7 out are thought to be influenced by passion (see Vallerand et al., 2006). Harmonious passion
8 emerges from the same autonomous internalisation as intrinsic motivation and is indicative of
9 a pattern of more self-determined regulation (c.f. Vallerand, 2008). In contrast, obsessive
10 passion emerges from more controlled internalisation and features the ego-investment and
11 introjected affect indicative of less self-determined regulation (Hodgins & Knee, 2002; Nie-
12 miec, Ryan & Brown, 2008). Clearly, the pattern of motivational regulation associated with
13 harmonious passion is indicative of motivational resiliency against burnout symptoms,
14 whereas the pattern of motivational regulation associated with obsessive passion is more con-
15 sistent with the nature of athlete burnout. Consequently, the degree to which obsessive and
16 harmonious passion encapsulate self-determined motivation may explain the relationship be-
17 tween passion and athlete burnout.

18 *The present study*

19 To date, no research has examined the relationships between forms of passion and
20 burnout in sport. Therefore, the first purpose of the current study was to examine the relation-
21 ships between harmonious and obsessive passion and athlete burnout. Consistent with re-
22 search in the occupational domain (Carbonneau et al., 2008; Vallerand et al., 2010), it was
23 hypothesised that harmonious passion would be negatively associated with athlete burnout
24 and obsessive passion would be positively associated with athlete burnout. The second pur-
25 pose was to test whether the relationships between different forms of passion and athlete

1 burnout would be mediated by self-determined motivation. The hypothesised relationships
2 within the model are displayed in Figure 1.

3 Method

4 *Participants and procedure*

5 One hundred and forty-nine (M age = 16.2, s = 2.0, range = 12-21) young male elite
6 soccer players, playing for an average of 9.1 (s = 2.9) years comprised the sample of this
7 study. Prior to data collection, ethical approval was provided by the research ethics commit-
8 tee of a British University. Soccer clubs who took part in the study were then contacted to
9 discuss the project and its' objectives. Participants, or parents or guardians when applicable,
10 were required to complete informed consent forms prior to participation in the study. Data
11 collection took place within a classroom or training session setting in the presence of the lead
12 author. On average the questionnaire required 20 minutes to complete.

13 *Instruments*

14 Passion for Sport. A 10 item version of the Passion Scale (adapted for soccer; Valle-
15 rand et al, 2003, study 4), with five items measuring harmonious (HP; e.g. "soccer allows me
16 to live a variety of experiences") and five items measuring obsessive (OP; e.g. "I cannot live
17 without soccer") passion was employed to measure athletes' passion for soccer. Athletes re-
18 sponded to each item on a 7-point Likert scale (1 = "Do not agree at all", 7 = "Very strongly
19 agree"). This form of the passion scale has been widely used and found reliable in various
20 domains including physical activity (e.g. Mageau, Vallerand, Rousseau, Ratelle, & Provench-
21 er, 2005; Rousseau & Vallerand, 2008). Rousseau and Vallerand (2008), for example, found
22 this version of the passion scale to be highly reliable in a sample of older adult exercisers (α =
23 .88 & .84 for harmonious and obsessive passion).

24 Self-determined motivation. To assess athletes' motivation in sport, the Sport Motiva-
25 tion Scale (SMS; Pelletier et al., 1995) was employed. This inventory consists of 28 items

1 assessing 7 subscales (4 items per subscale); intrinsic motivation to know (e.g. “I participate
2 in soccer for the pleasure it gives me to know more about my sport”), experience stimulation
3 (e.g. “I participate in soccer for the pleasure I feel in living exciting experiences”), and ac-
4 complish (“I participate in soccer because I feel a lot of personal satisfaction while mastering
5 certain difficult training techniques”), identified regulation (e.g. “I participate in soccer be-
6 cause it is one of the best ways to maintain good relationships with my friends”), introjected
7 regulation (e.g. “I participate in soccer because it is absolutely necessary if one wants to be in
8 shape”), external regulation (e.g. “I participate in soccer because I must do soccer to feel
9 good about myself”) and amotivation (e.g. “I participate in soccer but it’s not clear anymore;
10 I don’t really think my place is in soccer”). Athletes respond to how each item corresponds to
11 reasons they are presently practicing soccer on a 7-point Likert scale (1 = “does not corre-
12 spond at all”, 7 = “corresponds exactly”). Pelletier et al (1995) demonstrated initial reliability
13 of the SMS (mean $\alpha = .75$) for all subscales and Pelletier and Sarrazin (2007) in a thorough
14 review, found the SMS to be valid and reliable measure of sport motivation.

15 Following procedures outlined by Vallerand (2001), a self-determination index (SDI)
16 was calculated to reflect the athletes’ perceptions of self-determined motivation. This index is
17 obtained by multiplying each subscale by an assigned weight in accordance with its’ location
18 on the self-determination continuum. When calculating an SDI in the absence of integrated
19 regulation, Vallerand (2001) recommends weights of 2 for intrinsic motivation, 1 for identi-
20 fied regulation, -1 for introjected and external regulation, and -2 for amotivation. The prod-
21 uct scores were then summed to form an index of self-determination. The higher the score,
22 the more self-determined the motivation.

23 Athlete Burnout. To assess athlete burnout, the Athlete Burnout Questionnaire (ABQ;
24 Raedeke & Smith, 2001) was used. This multidimensional scale consists of 15 items that as-
25 sess three symptoms of burnout; sport devaluation (e.g. “I have negative feelings towards

1 soccer”), reduced sense of accomplishment (e.g. “I am not achieving much in soccer”) and
2 emotional/physical exhaustion (e.g. “I am exhausted by the mental and physical demands of
3 soccer”). Athletes respond according to the degree they experience each item over the last
4 month on a 5-point Likert scale (1 = “almost never, 5 = “almost always”). Raedeke and Smith
5 (2001) have provided initial support for the reliability of the instrument ($\alpha > .86$) and studies
6 have since confirmed its utility as a valid and reliable measure of athlete burnout (e.g. Cre-
7 swell & Eklund, 2005a,b,c; Lonsdale et al, 2009).

8 *Analytical strategy*

9 Path analysis was used to test the hypothesised model. Two exogenous variables (ob-
10 sensive and harmonious passion) and the mediator variable (SDI) were represented using
11 measured variables. The endogenous variable, athlete burnout, was represented as a latent
12 factor with its symptoms as measured manifest variables. This approach is akin to similar re-
13 search that has attempted to examine athlete burnout as a syndrome (e.g., Hill et al., 2008;
14 Hill, Hall, Appleton & Murray, 2010). A limitation of employing this mixed model approach
15 is that no error is modelled for the manifest variables. However, this method was considered
16 the most suitable because of the relatively small sample size and the necessity of a minimum
17 case to parameter ratio for coefficient stability (5:1; Kline, 1998).

18 Conventional criteria were used to assess the fit of the hypothesised model with the
19 observed data. Adequate fit was inferred when: TLI and CFI $> .90$, SRMR & RMSEA $< .10$,
20 $\chi^2/df < 3$ (Hu & Bentler, 1995), whereas Hu and Bentler’s (1999) criteria were employed as
21 evidence of good fit: TLI and CFI $> .95$, RMSEA $< .06$, SRMR $< .08$. The causal steps ap-
22 proach (see Holmbeck, 1997) was used to compare full and partial mediation. In a separate
23 analysis, indirect effects with bias corrected bootstrapped (1000 resamples) confidence inter-
24 vals were requested to assess the effect size and statistical significance of any mediation evi-
25 denced (Mackinnon, Lockwood & Williams, 2004; Shrout & Bolger, 2002).

1 Results

2 *Preliminary analysis*

3 No missing cases or significant univariate outliers ($p < .001$; Tabachnick & Fidell,
4 2001) were observed in the data. However, multivariate non-normality was identified (Mar-
5 dia's normalised coefficient = 5.90; Kline, 1998). Since the data was multivariate asymmet-
6 rical, in addition to the maximum likelihood estimation method, path analysis was conducted
7 using a bootstrap procedure consisting of 200 replication samples to estimate model fit and
8 assess parameter stability (Efron & Tibshirani, 1998). Reported estimates are those derived
9 from mean scores across the 200 iterations. Reliability analysis (Cronbach's α) revealed that
10 the measurement associated with the instruments used had adequate internal consistency (see
11 table 2; Lowenthal, 1996).

12 *Descriptive analyses, bivariate and partial correlations*

13 Using cut-off criteria (Raedeke, 1997; adapted by Hodge, Lonsdale & Ng, 2008) for
14 low and high experiences of burnout, a frequency distribution revealed that fifty two athletes
15 (35%) scored 2.30 or below for reduced accomplishment and exhaustion and 1.60 or below
16 for devaluation (i.e. low burnout). Eight participants (5.4%) scored greater than 2.70 for re-
17 duced accomplishment and 3.00 for exhaustion and devaluation on all burnout subscales (i.e.
18 high burnout). While the majority of the sample scored low-to moderate on burnout sub-
19 scales, this is consistent with previous research utilising similar elite junior samples (Apple-
20 ton et al, 2009; Hill et al, 2008) and elite adult samples (Cresswell & Eklund, 2005c; Hodge
21 et al, 2008; Lonsdale et al, 2009). Furthermore, the standard deviations associated with ath-
22 lete burnout symptoms indicate that there is sufficient variability in the data for the examina-
23 tion of relationships between study variables.

24 In line with previous research using the passion scale (e.g., Vallerand et al., 2006),
25 harmonious and obsessive passion were highly positively correlated ($r = .73, p < .01$). As a

1 result, bivariate and partial correlations were calculated (Table 1). Results indicate that, after
2 controlling for harmonious passion, obsessive passion was unrelated to the self-determination
3 index and all symptoms of athlete burnout. Having controlled for obsessive passion, harmo-
4 nious passion was positively associated with the self-determination index and inversely asso-
5 ciated with reduced accomplishment. Bivariate correlations indicated that the self-
6 determination index was inversely associated with all symptoms of athlete burnout.

7 *Path analysis*

8 Results from the path analysis are presented in Figure 2. Fit indexes suggested the hy-
9 pothesised model possessed an adequate fit to the data ($\chi^2 = 19.28 [8], p < .05; \chi^2/df = 2.4;$
10 $TLI = .94; CFI = .97; SRMR = .06; RMSEA = .10, 90\% CI = .04 to .15$). The path coefficient
11 between harmonious passion and SDI was statistically significant ($\gamma = .43, p < .01$). In con-
12 trast, the path coefficient between obsessive passion and SDI was non-significant. Finally, the
13 path coefficient between SDI and the latent burnout factor was significant ($\beta = -.64, p < .01$).
14 The model accounted for 18% of the variance in self-determined motivation and 43% of the
15 variance in the latent athlete burnout variable.

16 Because of the cross-sectional design, an alternative model was also tested. According
17 to the dualistic model, passions are assimilated in accord with the amount of autonomy the
18 environment provides (Vallerand et al., 2003). Furthermore, the same process is thought to
19 underpin contextual behavioural regulation (Deci & Ryan, 1985) and thus self-determined
20 motivation may precede passion. Based on this theoretical argument, an alternative model
21 was tested in which self-determined motivation was the measured exogenous variable and
22 assumed to be a positive and negative predictor of the measured mediating variables; harmo-
23 nious and obsessive passion respectively. Harmonious and obsessive passions were, in turn,
24 assumed to inversely and positively predict the latent endogenous athlete burnout variable
25 respectively. Results indicated that that this alternative model did not fit the data adequately

1 ($\chi^2 = 167.20$ [8], $p < .05$; $\chi^2/df = 20.90$; TLI = .15; CFI = .55; SRMR = .22; RMSEA = .38,
2 90% CI = .32 to .42).

3 *Assessment of mediation*

4 Mediation was assessed using a causal steps procedure (Holmbeck, 1997). The first
5 step requires an adequate fit of a model that includes only direct paths between the predictor
6 variables and the outcome variable (M1). The second step requires that the full mediation
7 model (no direct paths from passion to athlete burnout, only indirect paths via self-
8 determined motivation; M2) provides an adequate fit. All paths must be statistically signifi-
9 cant. The final step requires a fit comparison between the full mediation model (M2) and
10 partial mediation model (direct paths from passion to athlete burnout entered in addition to
11 indirect paths via self-determined motivation; M3). If there is no significant improvement in
12 fit between the full and partial mediation models, full mediation is demonstrated. If the paths
13 between the predictor and the outcome variables are reduced in M3 compared to M1 but still
14 significant, partial mediation is inferred.

15 CFI and SRMR fit indices indicated that the model in step one (M1) demonstrated ad-
16 equate fit (see Table 2). The path between obsessive passion and burnout was non-significant,
17 whereas the path between harmonious passion and athlete burnout was significant ($\gamma = -.16$, p
18 $< .01$). Thus, only mediation with respect to harmonious passion and athlete burnout is possi-
19 ble (Baron & Kenny, 1986). The full mediation model (M2) demonstrated adequate fit and
20 thus step two was met. With the exception of the paths between obsessive passion and out-
21 come variables, all paths were significant in the hypothesised direction. In the final step, the
22 full mediation model (M2) was compared with the partial mediation model (M3). A chi-
23 square difference test revealed that the two models do not differ in their degree of fit ($\Delta 1.23$
24 (2), $p > .05$). Moreover, the direct effect between harmonious passion and athlete burnout
25 reduced to non-significance in the partial mediation model (M3) ($\beta = -.16$, $p < .05$, to $\beta = -$

1 .01, $p > .05$). As a result, the analysis supports the full mediation model with respect to har-
2 monious passion (Holmbeck, 1997).

3 In a separate analysis, the effect size and statistical significance of the indirect effects
4 were determined by examining 95% bias corrected confidence intervals derived from 1000
5 bootstrapped resamples (Efron, 1988; Mackinnon et al, 2004). The bias corrected confidence
6 intervals for the indirect effect of harmonious passion on athlete burnout via self-determined
7 motivation excluded zero ($ab = -.17$, 95% BC CI = $-.28$ to $-.08$). Thus, the relationship be-
8 tween harmonious passion and athlete burnout is fully mediated and indirect via self-
9 determined motivation.

10 Discussion

11 The current study had two purposes. The first was to examine the relationship between pas-
12 sion and athlete burnout. It was hypothesised that harmonious passion would be negatively
13 associated with athlete burnout, whereas obsessive passion would be positively associated
14 with athlete burnout. The second purpose was to examine whether self-determined motivation
15 mediates the relationship between forms of passion and burnout. It was hypothesised that
16 self-determined motivation would mediate the relationships between passion and athlete
17 burnout. Results revealed that harmonious passion was inversely correlated with the latent
18 burnout variable. Contrary to expectations, obsessive passion was unrelated to athlete burn-
19 out. Self-determined motivation fully mediated the relationship between harmonious passion
20 and athlete burnout. However, no mediation was found in the case of obsessive passion and
21 athlete burnout.

22 *Passion and athlete burnout*

23 The finding that harmonious passion inversely correlated with the latent athlete burn-
24 out variable extends research in this area by replicating findings in an occupational context
25 (Carbonneau et al, 2009; Vallerand et al, 2010). It appears that this form of passion may ame-

1 liorate the burnout syndrome for athletes as it does in other groups. Thus in a practical sense,
2 the more one identifies with harmonious passion, the less likely they are to report symptoms
3 of athlete burnout. This discovery supports a growing body of research that has evidenced the
4 adaptive role of harmonious passion in sport (see Vallerand & Miquelon, 2007). Further, in
5 the context of athlete burnout, this finding can also be considered to contribute to an under-
6 standing of the mitigating constituents of the syndrome.

7 With regard to obsessive passion, a positive association with athlete burnout was ex-
8 pected in a manner that has been found in an occupational context (Carbonneau et al, 2008;
9 Vallerand et al, 2010). Contrary to this expectation, obsessive passion was unrelated to ath-
10 lete burnout in the current study. As a result, no relationship appears to exist between these
11 two constructs. Nevertheless, it is notable that obsessive passion did not inversely correlate
12 with athlete burnout. Therefore, unlike harmonious passion, obsessive passion does not seem
13 to actively mitigate the athlete burnout syndrome. In accord with the findings of previous re-
14 search, it appears that not all forms of passion for sport are adaptive (see Vallerand & Mique-
15 lon, 2007).

16 Although it is not clear why obsessive passion did not positively associate with athlete
17 burnout, it is possible that contextual differences in the conceptualisation of burnout may ac-
18 count for this finding. Specifically, occupational burnout contains a symptom of depersonali-
19 sation, whereas in sport the burnout symptom of depersonalisation is replaced by devaluation
20 (Raedeke & Smith, 2001). While depersonalisation refers to a detachment from clients, de-
21 valuation refers to a decrease in the importance of sport participation. Obsessive passion
22 might be expected to lead to self-closure from intra-personal experience (i.e. depersonalisa-
23 tion) since overall worth is often staked upon conditional regard when ego involved (Assor,
24 Roth, & Deci, 2004). However, obsessive passion is characterised by a compulsive attraction
25 to the task (Vallerand, 2008). Thus, this form of passion may not lead to any reduced sense of

1 value associated with participation (i.e. devaluation). In support of this possibility, obsessive
2 passion has been positively associated with activity valuation (Vallerand et al, 2003, study 1)
3 and high levels of behavioural investment (Vallerand et al, study 3). Future research is re-
4 quired in order to examine potential contextual differences.

5 *The mediating role of self-determined motivation*

6 The assessment of mediation produced mixed findings. Self-determined motivation
7 fully explained the relationship between harmonious passion and athlete burnout but no me-
8 diation was evident in terms of obsessive passion. This model thus offers some insight into
9 the passion-athlete burnout relationship. In particular, the more self-determined pattern of
10 motivational regulation encompassed by harmonious passion accounts for the lower levels of
11 athlete burnout associated with this form of passion. Further, consistent with the operational
12 definitions of forms of passion, it appears that harmonious passion encompasses a more self-
13 determined pattern of motivation than obsessive passion in sport. This difference in motiva-
14 tional quality may, in part, account for the divergent relationships between forms of passion
15 and cognitive/affective outcomes.

16 These findings also extend previous research by identifying an additional explanation
17 for the relationship between harmonious passion and burnout. Recently, Vallerand et al
18 (2010) found that life satisfaction and conflict with other life spheres mediated the relation-
19 ship between harmonious passion and occupational burnout. It may be that the mediating
20 processes in the current study and those observed by Vallerand and colleagues are part of a
21 larger process. Specifically, more self-determined motivation may facilitate positive affect
22 (i.e. life satisfaction) and thwart negative cognition (i.e. conflict with other life spheres),
23 which in turn mitigates athlete burnout. Future research may wish to examine this possibility.

24 In the case of obsessive passion, the findings do not support the utility of self-
25 determined motivation as an intervening variable. This was an unexpected finding since it is

1 considered that obsessive passion encompasses controlled motivational regulation (c.f. Valle-
2 rand, 2008) similar to that which characterises burnout (Lemyre et al, 2006). It is possible
3 that despite obsessive passion being indicative of less self-determined motivation (e.g., intro-
4 jection), it does not encapsulate the most central antecedent of athlete burnout; namely, amo-
5 tivation (Cresswell & Eklund, 2005a,b,c). Therefore, this form of passion may not fully cap-
6 ture the “motivational signature” of the burnout syndrome in sport (see Eklund & Cresswell,
7 2007; Gould, 1996). Instead, obsessive passion may be best considered as an indicator of
8 poorer motivational quality in tandem with high motivational quantity. This possibility is
9 supported by Vallerand and colleagues (2003) who have found that obsessive passion ener-
10 gises high levels of behavioural investment, even when it is not sensible to do so. In other
11 words, despite many other negative outcomes relative to harmonious passion (see Vallerand
12 & Miquelon, 2007), obsessive passion may not necessarily encompass a pattern of amotiva-
13 tion that predisposes athletes to burnout. Longitudinal research is required to examine this
14 conjecture.

15 *Alternative model testing*

16 In addition to the hypothesised model, an alternative model was tested. The alterna-
17 tive model proposed that self-determined motivation is an antecedent of passion, as opposed
18 to the reverse. This was based on the possibility that forms of passion and behavioural regula-
19 tion can be considered to emerge from the same processes of activity internalisation, and thus
20 the relationship between passion and contextual motivation is not easily disentangled. Results
21 indicated that the alternative model provided a poor fit to the observed data. Consequently,
22 the study provides initial support for suggestion that passions precede behavioural regulation.
23 Though passion and behavioural regulation share internalisation processes, they are distin-
24 guished by the *degree* to which behaviour is internalised, and not the internalisation process
25 per se. Whereas passion is internalised into one’s identity, behavioural regulations operate at

1 a more proximal level and do not constitute identity space (see Vallerand, 2008). According-
2 ly, once assimilated, passions can be considered to precipitate contextual motivational pro-
3 cesses (see Vallerand et al, 2006). In the case of athlete burnout, these findings should be
4 considered to provide initial evidence that self-determined motivation can account for vari-
5 ance shared between harmonious passion and the syndrome. Future research is now required
6 to test the directionality of these relationships over time.

7 *Limitations and future research*

8 The present study has a number of limitations. Firstly, because of the specific sample,
9 the results cannot be generalised beyond the context of young elite male soccer players. The
10 replication of this study to females and other sports would enhance the external validity of the
11 findings for the athletic population. In addition, components of passion and self-determined
12 motivation were modelled in the absence of measurement error. This can lead to an underes-
13 timation of direct and indirect effects (Shrout & Bolgar, 2002). The absence of a relationship
14 between obsessive passion and self-determined motivation may have been a consequence of
15 taking this approach. Moreover, direct model comparison is not possible when models are not
16 nested. Similarly, the cross-sectional design precludes any inference of causality. Therefore,
17 longitudinal designs are required to begin to determine the validity of the current variable con-
18 figuration.

19 Specific motivational regulations were omitted from the current study due to case-to-
20 parameter restrictions. Future research would benefit from an examination of the relation-
21 ships between passion and discrete forms of motivational regulation. This is particularly im-
22 portant for determining the precise motivational valence of obsessive passion and the degree
23 to which obsessive passion encompasses the motivational features of athlete burnout. Finally,
24 future research may wish to focus upon identifying other mediating processes, such as psy-
25 chological need satisfaction and thwarting, which precede self-determined motivation (Valle-

1 rand et al, 2006). Similarly, modelling the cognitive (e.g., rumination), affective (e.g., satis-
2 faction) and behavioural (e.g., persistence) outcomes associated with passion would provide a
3 particularly useful insight into the passion-burnout relationship.

4 *Conclusion*

5 Although burnout has been identified as a corrosive syndrome for sports participants
6 (Gould et al, 1996), the mechanisms that explain its development in junior athletes are not
7 clearly understood. The current study extends understanding of athlete burnout by suggesting
8 that harmonious passion may provide some resilience to the development of burnout. Fur-
9 thermore, the current findings suggest that higher levels of self-determined motivation may
10 explain the inverse relationship between harmonious passion and burnout. This latter finding
11 substantiates a growing body of research that highlights the adaptive role of harmonious pas-
12 sion for athletes. In contrast, the research did not find support for the hypothesised positive
13 association between obsessive passion and athlete burnout. As this relationship has been
14 found elsewhere, future research is required to examine this relationship further.

15 References

- 16 Appleton, P. R., Hall, H. K., & Hill, A. P. (2009). Relations between multidimensional per-
17 fectionism and burnout in junior-elite male athletes. *Psychology of Sport & Exercise*,
18 *10*, 457-465.
- 19 Assor, A., Roth, G., & Deci, E. L. (2004). The emotional costs of perceived parents' condi-
20 tional regard: A self-determination theory analysis. *Journal of Personality*, *72*, 47-89.
- 21 Baron, R. M., & Kenny, D. A. (1986). The moderator-mediator variable distinction in social
22 psychological research: Conceptual, strategic, and statistical considerations. *Journal*
23 *of Personality & Social Psychology*, *51*, 1173-1182.
- 24 Brenner, J. S. (2007). Overuse injuries, overtraining, and burnout in child and adolescent ath-
25 letes. *Paediatrics*, *119*, 1242-1245.

- 1 Carbonneau, N., Vallerand, R. J., Fernet, C., & Guay, F. (2008). The role of passion for
2 teaching in intra and interpersonal outcomes. *Journal of Educational Psychology, 100*,
3 977-987.
- 4 Cresswell, S. L., & Eklund, R. C. (2005a). Motivation and burnout among top amateur rugby
5 players. *Medicine and Science in Sports and Exercise, 37*, 469-477.
- 6 Cresswell, S. L., & Eklund, R. C. (2005b). Motivation and burnout professional rugby play-
7 ers. *Research Quarterly for Exercise & Sport, 76*, 370-376.
- 8 Cresswell, S. L., & Eklund, R. C. (2005c). Changes in athlete burnout and motivation over a
9 12-week league tournament. *Medicine and Science in Sport and Exercise, 37*, 1957-
10 1966.
- 11 Dall, J. (2009, May 10th). Arsene warns of Theo burnout. *Sky Sports News* (online). Available
12 from: http://www.skysports.com/story/0,19528,12098_5308514,00.html. [Accessed
13 12th May., 2009]
- 14 Deci, E. L., Ryan, R. M. (1985) *Intrinsic Motivation and Self-Determination in Human Be-*
15 *havior*. New York, Plenum Press.
- 16 Efron, B. (1988). Bootstrap confidence intervals: Good or bad? *Psychological Bulletin, 105*,
17 293-296.
- 18 Efron, B., & Tibshirani, R. J. (1998). *An introduction to the bootstrap*. Boca Raton, CRC
19 Press.
- 20 Eklund, R. C., & Cresswell, S. L. (2007). Athlete burnout. In G. Tenenbaum & R. C. Eklund
21 (Eds.), *Handbook of sport psychology* (3rd Ed., pp. 621–641). Hoboken, NJ: Wiley.
- 22 Gillet, N., Vallerand, R. J., Amoura, S., & Baldes, B. (2010). Influence of coaches' autonomy
23 support on athletes' motivation and sport performance: A test of the hierarchal model
24 of intrinsic and extrinsic motivation. *Psychology of Sport & Exercise, 11*, 155-161.

- 1 Gould, D. (1996). Personal motivation gone awry; Burnout in competitive athletes. *Quest*, 48,
2 275-289.
- 3 Gould, D., Udry, E., Tuffey, S., & Loehr, J. (1996). Burnout in competitive junior tennis
4 players: I. A quantitative psychological assessment. *The Sport Psychologist*, 10, 322-
5 340.
- 6 Gustafsson, H., Kentta, G., Hassmen, P., & Johansson, M. (2008) A qualitative analysis of
7 burnout in elite Swedish athletes. *Psychology of Sport and Exercise*, 9, 800-816.
- 8 Harlick, M., & McKenzie, A. (2000). Burnout in junior tennis: A research report. *The New*
9 *Zealand Journal of Sports Medicine*, 28, 36-39.
- 10 Hill, A. P., Hall, H. K., Appleton, P. R., & Kozub, S. R. (2008). Perfectionism and burnout in
11 junior elite soccer players: The mediating influence of unconditional self-acceptance.
12 *Psychology of Sport & Exercise*, 9, 630-644.
- 13 Hill, A. P., Hall, H. K., Appleton, P. R., & Murray, J. J. (2010). Perfectionism and burnout in
14 canoe polo and kayak slalom athletes: The mediating influence of validation and
15 growth-seeking. *The Sport Psychologist*, 24, 16-34.
- 16 Hodge, K., Lonsdale, C., & Ng, J.Y.Y. (2008). Burnout in elite rugby: Relationships with
17 basic psychological needs fulfilment. *Journal of Sports Sciences*, 26, 835–844.
- 18 Hodgins H. S., & Knee, C. R. (2002). The integrating self and conscious experience. In E. L.,
19 Deci, & R. M., Ryan (Eds.). *Handbook of self-determination research* (pp. 87-100).
20 Rochester, University of Rochester press.
- 21 Holmbeck, G. N. (1997). Toward terminological, conceptual, and statistical clarity in the
22 study of mediators and moderators: Examples from the child-clinical and paediatric
23 psychology literatures. *Journal of Counselling & Clinical Psychology*, 65, 599-610.
- 24 Hu, L. T., & Bentler, P. (1995). Evaluating model fit. I R. H. Hoyle (Ed.) *Structural equation*
25 *modelling: Concepts, issues, and applications* (pp. 76-99). Thousand Oaks, CA: Sage.

- 1 Hu, L. T., & Bentler, P. (1999). Cutoff criteria for fit indexes in covariance structure analysis:
2 Conventional criteria versus new alternatives. *Structural Equation Modeling: A Mul-*
3 *tidisciplinary Journal*, 6, 1-55.
- 4 Kline, R. B. (1998). *Principles and practice of structural equation modelling* (1st Ed.). New
5 York: Guilford Press.
- 6 Lemyre, P. N., Treasure, D. C., & Roberts, G. C. (2006). Influence of variability in motiva-
7 tion and affect on elite athlete burnout susceptibility. *Journal of Sport & Exercise*
8 *Psychology*, 28, 32-48.
- 9 Loewenthal, K. M. (1996). *An introduction to psychological tests and scales*. UCL Press,
10 London.
- 11 Lonsdale, C., Hodge, K., & Rose, E. (2009). Athlete burnout in elite sport: A self-
12 determination perspective. *Journal of Sports Sciences*, 27, 785-795
- 13 Mackinnon, D. P., Lockwood, C. M., & Williams, J. (2004). Confidence limits for the indi-
14 rect effect: Distribution of the product and resampling methods. *Multivariate Behav-*
15 *ioural Research*, 30, 99-128.
- 16 Mageau, G. A., Vallerand, R. J., Rousseau, F. L., Ratelle, C. F., & Provencher, P. J. (2005).
17 Passion and gambling: Investigating the divergent affective and cognitive conse-
18 quences of gambling. *Journal of Applied Social Psychology*, 35, 100–118.
- 19 Maslach, C., & Jackson, S. E. (1986). *Maslach burnout inventory manual* (2nd Ed). Palo Alto:
20 Consulting Psychologists Press.
- 21 Niemiec, C. P., Ryan, R. M., & Brown, K. W. (2008). The role of awareness and autonomy
22 in quieting the ego: A self-determination theory perspective. In H. A. Wayment & J. J.
23 Bauer (Eds.), *Transcending self-interest: Psychological explorations of the quiet ego*
24 (pp. 107-116). Washington, DC: American Psychological Association.

- 1 Pelletier, L. G., & Sarrazin, P. (2007). Measurement issues in self-determination theory and
2 sport. In M. S. Hagger & N. L. D. Chatzisarantis (Eds.), *Intrinsic motivation and self-*
3 *determination in exercise and sport* (pp. 143–152). Champaign, IL: Human Kinetics.
- 4 Pelletier, L. G., Fortier, M. S., Vallerand, R. J., Tuson, K. M., Brière, N. M., & Blais, M. R.
5 (1995). Toward a new measure of intrinsic motivation, extrinsic motivation, and
6 amotivation in sports: The Sport Motivation Scale (SMS). *Journal of Sport & Exer-*
7 *cise Psychology, 17*, 35-53.
- 8 Raedeke, T. D. (1997). Is athlete burnout more than just stress? A sport commitment perspec-
9 tive. *Journal of Sport & Exercise Psychology, 19*, 396-417.
- 10 Raedeke, T. D., & Smith, A. L. (2001). Development and preliminary validation of an athlete
11 burnout measure. *Journal of Sport & Exercise Psychology, 23*, 281-306.
- 12 Raedeke, T. D., & Smith, A. L. (2004). Coping resources and athlete burnout: An examina-
13 tion of stress mediated and moderation hypothesis. *Journal of Sport & Exercise Psy-*
14 *chology, 26*, 525-541.
- 15 Ratelle, C. F., Vallerand, R. J., Mageau, G. A., Rousseau, F. L., & Provencher, P. (2004).
16 When passion leads to problematic outcomes: A look at gambling. *Journal of Gam-*
17 *bling Studies, 20*, 105-119.
- 18 Rip, B., Fortin, S., & Vallerand, R. J. (2006). The relationship between passion and injury in
19 dance students. *Journal of Dance Medicine & Science, 10*, 14–20.
- 20 Rousseau, F. L., & Vallerand, R. J. (2008). An examination of the relationship between pas-
21 sion and subjective well-being in older adults. *International Journal of Aging and*
22 *Human Development, 66*, 195-211.
- 23 Seguin-Le´vesque, C., Laliberte´, M.-L., N., Pelletier, L.G., Blanchard, C.M., & Vallerand,
24 R.J. (2003). Harmonious and obsessive passion for the internet: Their associations
25 with couple’s relationships. *Journal of Applied Social Psychology, 33*, 197–221.

- 1 Shrout, P. E., & Bolger, N. (2002). Mediation in experimental and non-experimental studies:
2 New procedures and recommendations. *Psychological Methods*, 7, 422-445.
- 3 Tabachnick, B. G., & Fidell, L. S. (2001). *Using multivariate statistics*. London, Allyn and
4 Bacon.
- 5 Taylor, I. M., Ntoumanis, N., & Standage, M. (2008). A self-determination theory approach
6 to understanding the antecedents of teachers' motivational strategies in physical edu-
7 cation. *Journal of Sport & Exercise Psychology*, 30, 75-94.
- 8 Vallerand, R. J. (1997). Toward a hierarchical model of intrinsic and extrinsic motivation. In
9 Zanna, M. (Ed.), *Advances in experimental social psychology*. Academic Press, San
10 Diego.
- 11 Vallerand, R. J. (2001). A hierarchical model of intrinsic and extrinsic motivation in sport
12 and exercise. In G. C. Roberts (Ed.) *Advances in motivation in sport and exercise* (pp.
13 263–320). Champaign, IL: Human Kinetics.
- 14 Vallerand, R. J. (2008). On the psychology of passion: In search of what makes people's lives
15 most worth living. *Canadian Psychology*, 49, 1-13.
- 16 Vallerand, R. J., & Miquelon, P. (2007). Passion for sport in athletes. In Jowett, S. Lavallee,
17 D (Eds), *Social psychology in sport* (pp. 249-263). Champaign, Human Kinetics.
- 18 Vallerand, R. J., Blanchard, C. M., Mageau, G. A., Koestner, R., Ratelle, C., Leonard, M.,
19 Gagne, M., & Marsolais, J. (2003). Les passions de l'ame: on obsessive and harmo-
20 nious passion. *Journal of Personality & Social Psychology*, 85, 756-767.
- 21 Vallerand, R. J., Mageau, G. A. Elliot, A. Dumais, M. A. Demers, M. & Rousseau, F. L.
22 (2008). Passion and performance attainment in sport. *Psychology of Sport & Exercise*,
23 9, 373-392.
- 24 Vallerand, R. J., Paquet, Y., Philippe, F. L., & Charest, J. (2010). On the role of passion for
25 work in burnout: A process model. *Journal of Personality*, 78, 289-312.

- 1 Vallerand, R. J., Rousseau, F. L., Grouzet, F. M. E., Dumais, A., & Grenier, S. (2006). Pas-
- 2 sion in sport: A look at determinants and affective experiences. *Journal of Sport &*
- 3 *Exercise Psychology*, 28. 455-478.

4

5

Table 1 *Descriptive statistics and bivariate and partial correlation coefficients between passion, SDI and symptoms of athlete burnout*

	1	2	3	4	5	6	M (s)	α
1. Harmonious passion	---		.32**	-.19*	-.10	-.12	5.48 (.90)	.69
2. Obsessive passion	.73**	---	-.02	-.04	.06	-.12	5.04 (1.2)	.82
3. SDI	.42**	.29**	---				5.84 (3.5)	.62-.89
4. Burnout – Reduced accomplishment	-.31**	-.25**	-.54**	---			2.15 (.67)	.73
5. Burnout – Exhaustion	-.08	-.02	-.39**	.59**	---		2.46 (.86)	.87
6. Burnout – Devaluation	-.27**	-.29**	-.54**	.60**	.57**	---	1.63 (.73)	.81

Note. Partial correlations appear above the diagonal, and bivariate correlations appear below the diagonal. The individual Cronbach alpha's for discrete behavioural regulations were as follows; intrinsic motivation = .89; identified regulation = .81; introjected regulation = .72; external regulation = .62; amotivation = .82. *M* = mean, *s* = standard deviation; α = Cronbach alpha; SDI = Self-determination index. ** $p < .01$, * $p < .05$.

Table 2 *Fit of structural models and indirect effect of; harmonious passion → SDI → athlete burnout*

	χ^2 (d.f)	χ^2 /d.f	TLI	CFI	SRMR	RMSEA (90% CI)	$\Delta\chi^2$ (df)
M1: Absence of mediator	16.41 (4)*	4.10	.89	.96	.06	.15 (.08 to .22)	
M2: Full mediation	19.30 (8)*	2.41	.94	.97	.06	.10 (.04 to .15)	
M3: Partial mediation	18.10 (6)*	3.00	.92	.97	.06	.12 (.05 to .18)	M2 vs M3 = 1.23 (2) <i>ns</i>

Note: M1 = In this model both components of passion have a direct pathway to athlete burnout; M2 = In this model components of passion have only indirect pathways to athlete burnout via self-determined motivation; M3 = In this model both direct and indirect pathways from components of passion to athlete burnout are included. χ^2 = Chi Square; *d.f* = Degrees Freedom; *TLI* = Tucker Lewis Index; *CFI* = Comparative Fit Index; *SRMR* = Standardised Root Mean Square Residual; *RMSEA* = Root Mean Squared Error of Approximation. * $p < .05$, *ns* = non-significant.

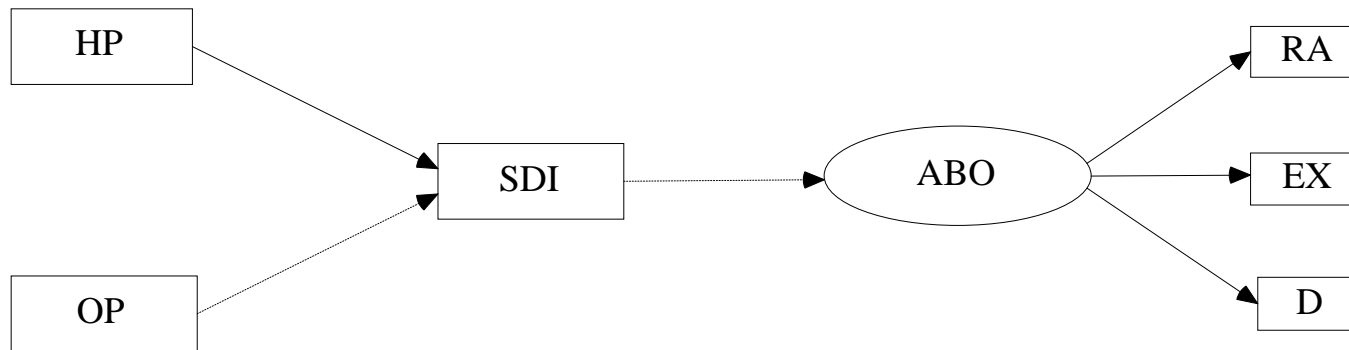

Figure 1. Hypothesised path model of passion, self-determined motivation and athlete burnout.. *Note; dashed lines indicate a hypothesised negative relationship; un-dashed lines indicate a positive relationship; HP = Harmonious passion, OP = Obsessive passion, SDI = Self-determination index, ABO = Athlete burnout, RA = Reduced accomplishment, EX = Exhaustion, D = Devaluation.*

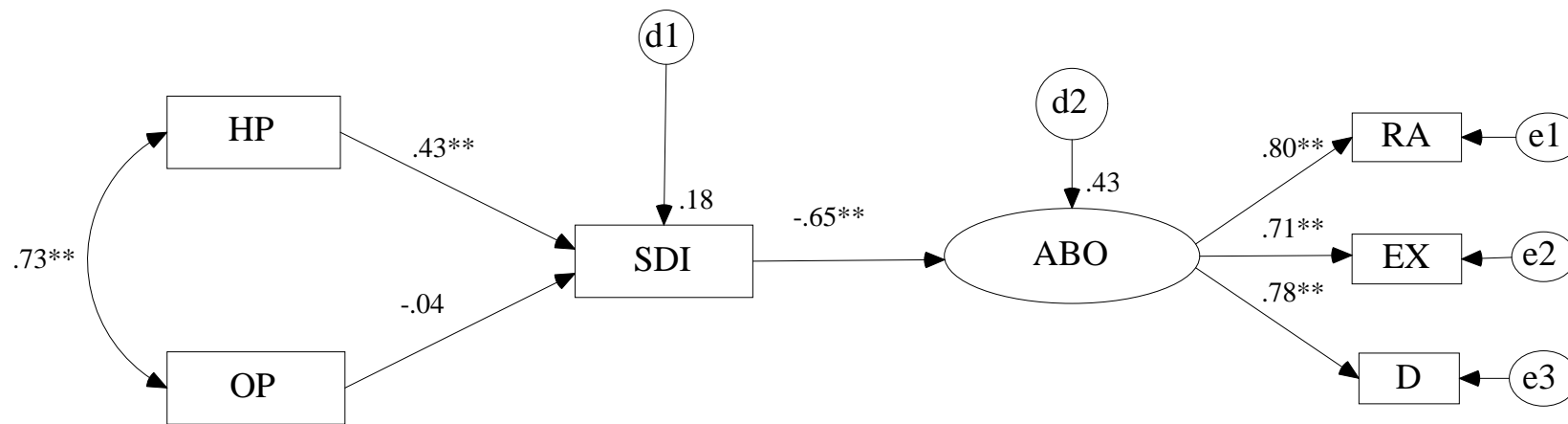

Figure 2 Results of path analysis: The mediating role of self-determined motivation on the relationship between passion and athlete burnout. *Note; HP = Harmonious passion, OP = Obsessive passion, SDI = Self-determination index, ABO = Athlete burnout, RA = Reduced accomplishment, EX = Exhaustion, D = Devaluation, e = error term, d = disturbance term, **p <.01.*